

DESIGN INFORMATION

For Design information, see Plate 5.1.1c

**CONNECTICUT
BRIDGE DESIGN
MANUAL**

SECTION PROPERTIES
AASHTO CONCRETE
SLABS - 3'- 0" WIDE

Issue Date: 10/03

Revision Date:

Plate Number:
5.1.1a

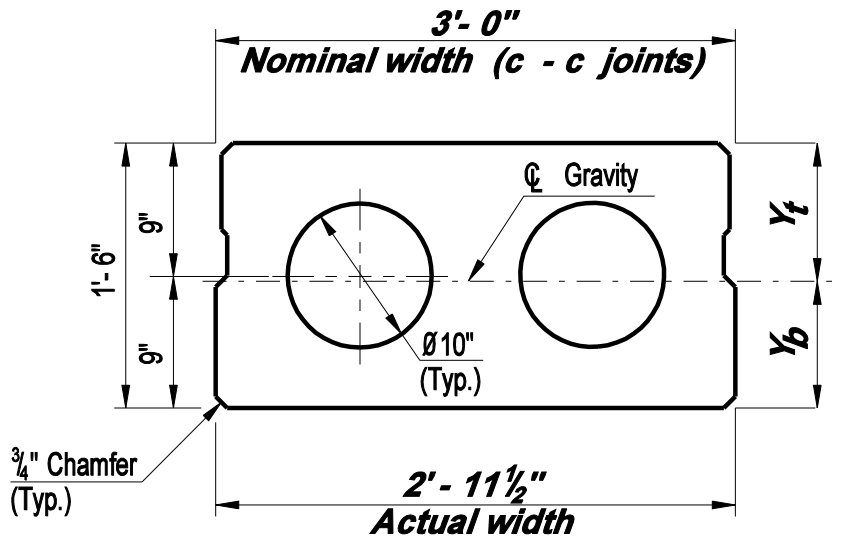

SIII - 36"

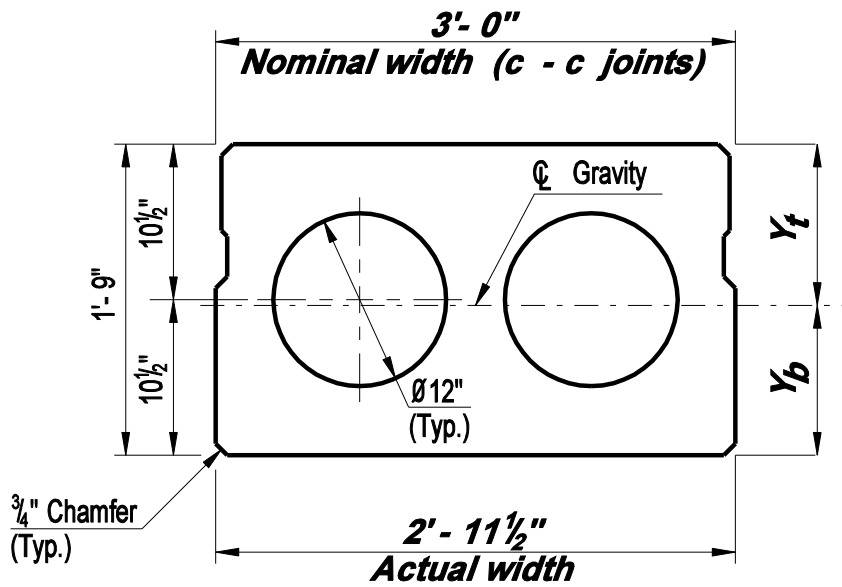

SIV - 36"

DESIGN INFORMATION

For Design information, see Plate 5.1.1c

**CONNECTICUT
BRIDGE DESIGN
MANUAL**

**SECTION PROPERTIES
AASHTO CONCRETE
SLABS - 3'- 0" WIDE**

Issue Date: 10/03
Revision Date: 01/05
Plate Number:
5.1.1c

BEAM TYPE	Width		Depth (inch)	A (inch ²)	I (inch ⁴)	Y _b (in.)	Y _t (in.)	S _b (inch ³)	S _t (inch ³)	Wt. (lb/ft)
	Nom. (inch)	Act. (inch)								
	SI-36	36.0								
SII-36	36.0	35.5	15.0	438	9728	7.44	7.56	1309	1287	457
SIII-36	36.0	35.5	18.0	473	16034	8.92	9.08	1798	1766	493
SIV-36	36.0	35.5	21.0	511	24987	10.40	10.60	2403	2358	532

DESIGN INFORMATION

- 1. Weight of beam does not include weight of solid sections at transverse ties. Use the total weight (including solid sections) for design.*
- 2. Voids may be eliminated to develop sidewalk/parapet reinforcement. See Section 5.6. The designer shall calculate and use the Modified Properties in this case.*
- 3. For design details, see Plate 5.1.1a & 5.1.1b*
- 4. If anchors must be drilled-in directly above a void for the purpose of anchoring Temporary Precast Concrete Barrier Curb, the size of the void should be adjusted to provide at least eight inches of thickness at the anchor locations.*

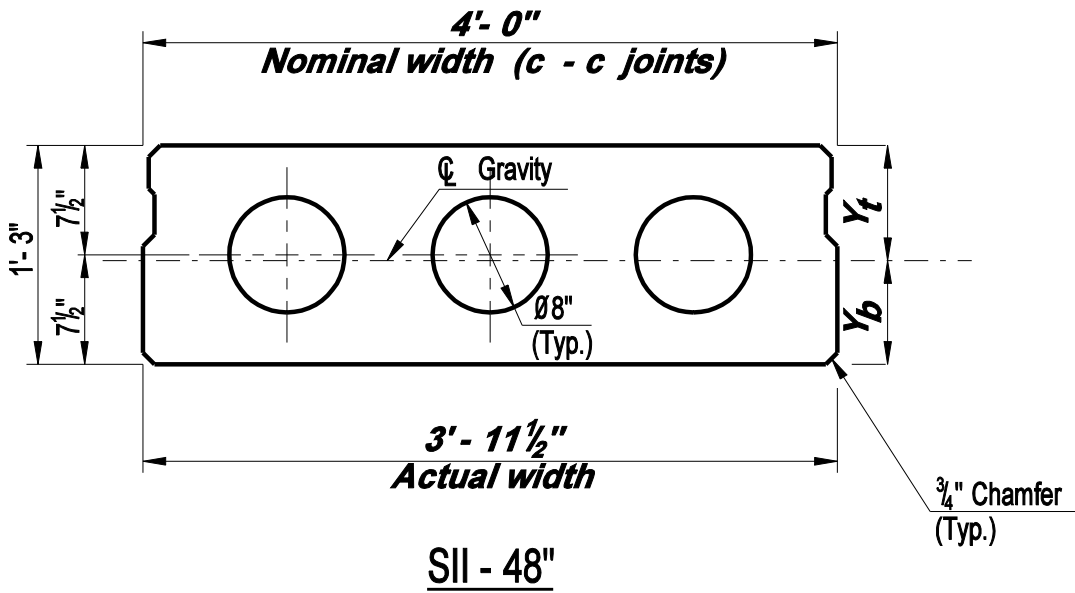
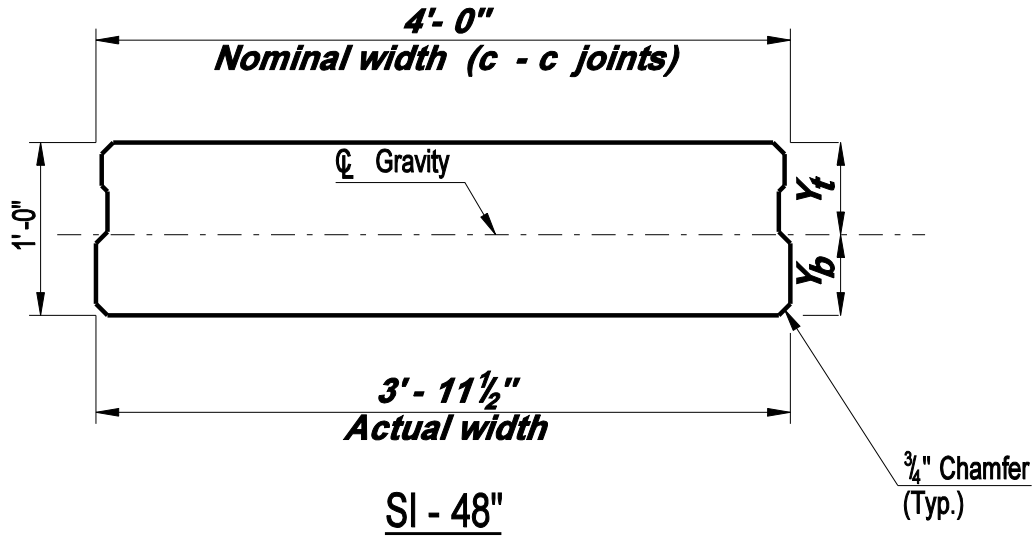

DESIGN INFORMATION

For design information, see Plate 5.1.2c

**CONNECTICUT
BRIDGE DESIGN
MANUAL**

**SECTION PROPERTIES
AASHTO CONCRETE
SLABS - 4'- 0" WIDE**

Issue Date: 10/03

Revision Date: 01/05

Plate Number:
5.1.2a

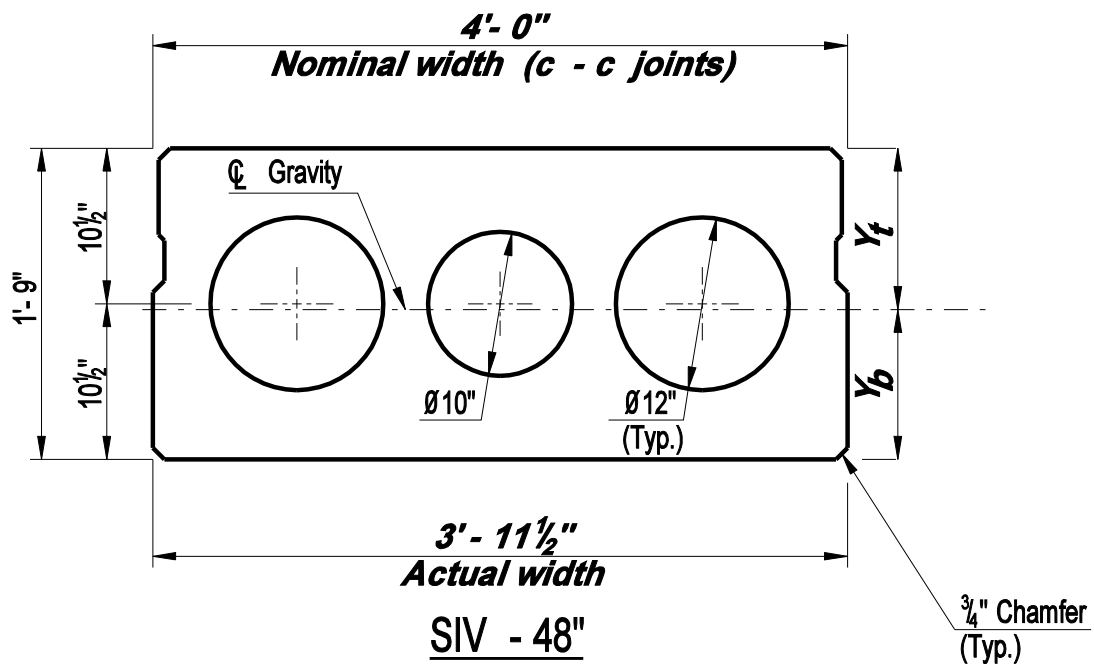
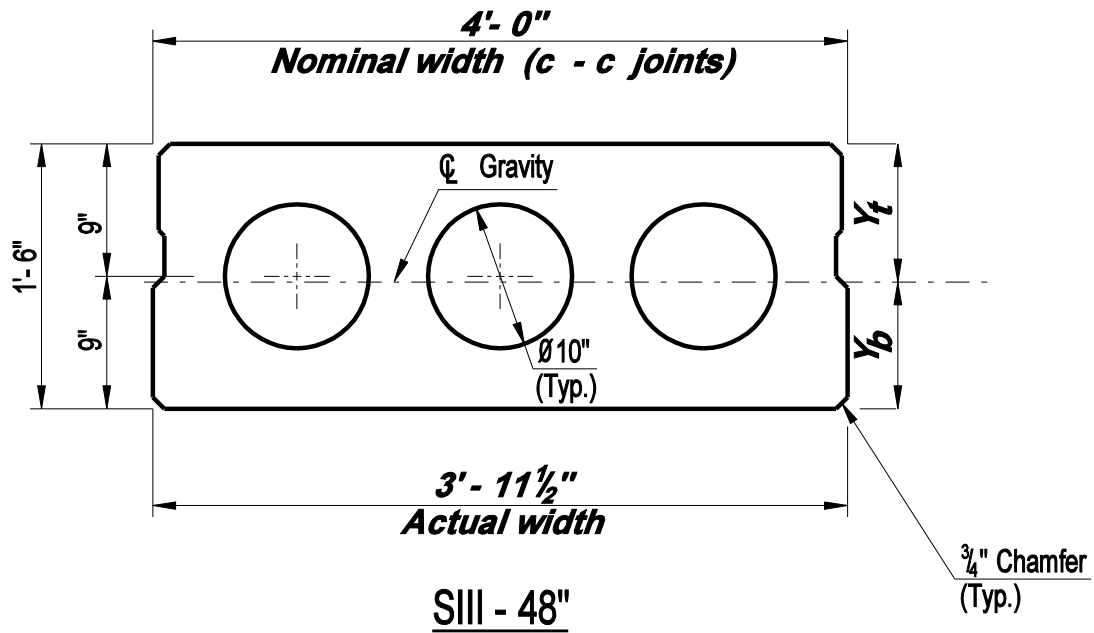

DESIGN INFORMATION

For design information, see Plate 5.1.2c

**CONNECTICUT
BRIDGE DESIGN
MANUAL**

**SECTION PROPERTIES
AASHTO CONCRETE
SLABS - 4'- 0" WIDE**

Issue Date: 10/03

Revision Date:

Plate Number:
5.1.2b

BEAM TYPE	Width		Depth	A	I	Y _b	Y _t	S _b	S _t	Wt.
	Nom. (inch)	Act. (inch)								
SI-48	48.0	47.5	12.0	561	6773	5.97	6.03	1135	1124	585
SII-48	48.0	47.5	15.0	553	12622	7.45	7.55	1695	1672	576
SIII-48	48.0	47.5	18.0	611	21376	8.94	9.06	2393	2359	636
SIV-48	48.0	47.5	21.0	684	33759	10.43	10.57	3238	3193	713

DESIGN INFORMATION

1. Weight of beam does not include weight of solid sections at transverse ties. Use the total weight (including solid sections) for design.
2. Voids may be eliminated to develop sidewalk/parapet reinforcement. See Section 5.6. The designer shall calculate and use the Modified Properties in this case.
3. For design details, see Plates 5.1.2a & 5.1.2b

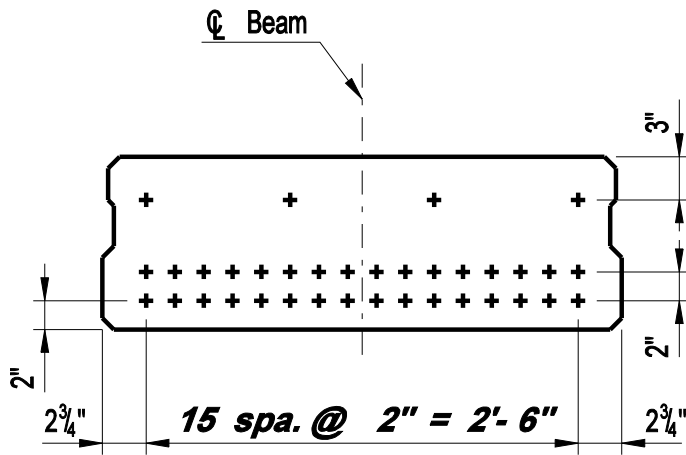

SI - 36"

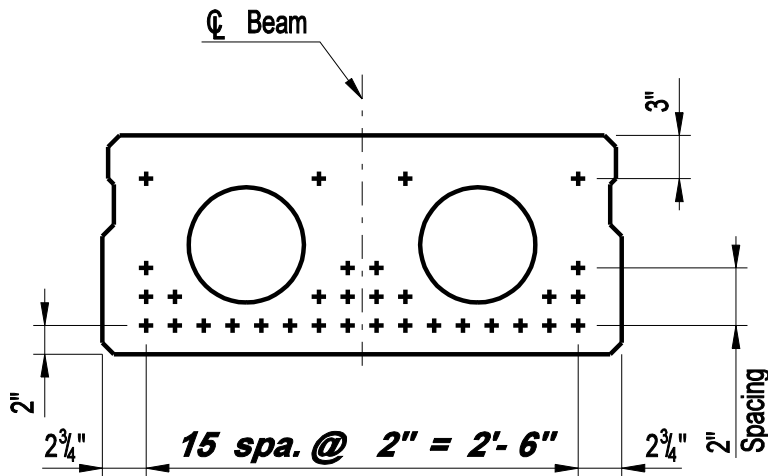

SII - 36"

DESIGN INFORMATION

For Design Information, see Plate 5.1.7

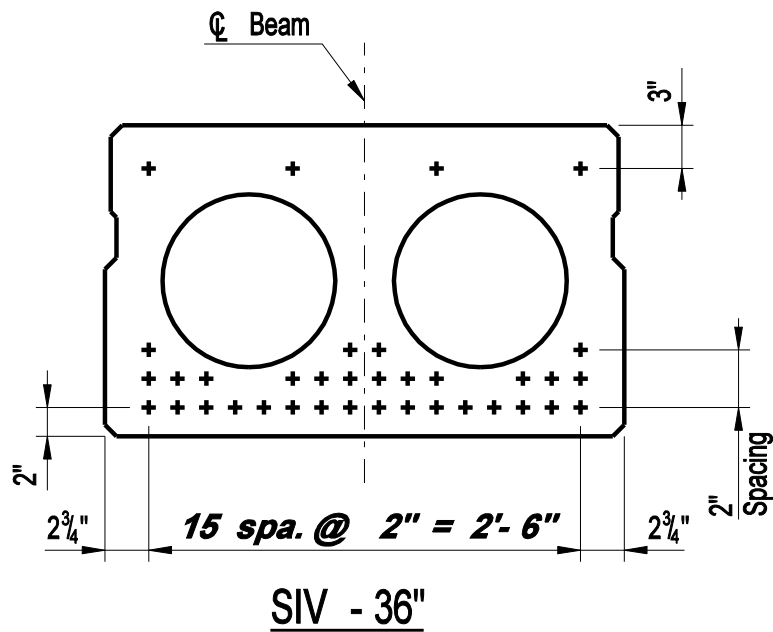
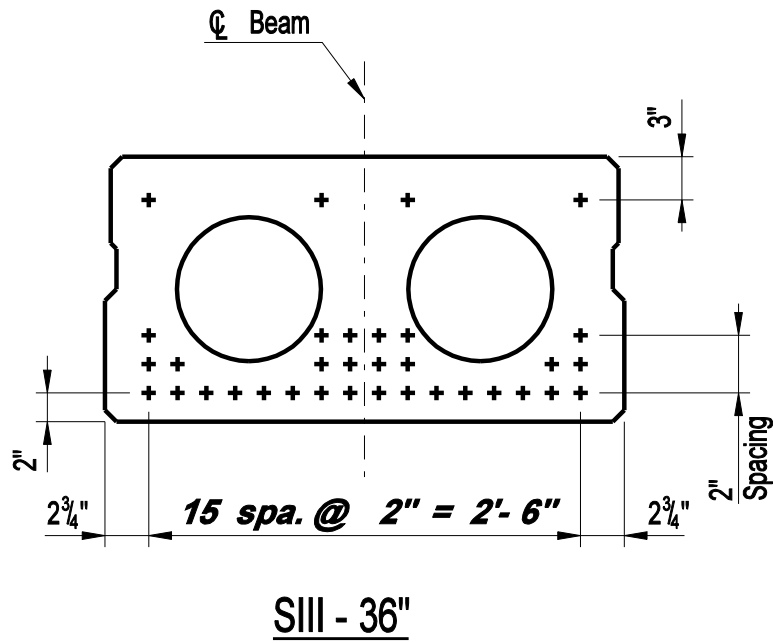

DESIGN INFORMATION

Design Information, see Plate 5.1.7

**CONNECTICUT
BRIDGE DESIGN
MANUAL**

STRAND LOCATIONS
AASHTO CONCRETE SLABS
(S III & S IV - 3'-0" WIDE)

Issue Date: 10/03

Revision Date:

Plate Number:

5.1.4

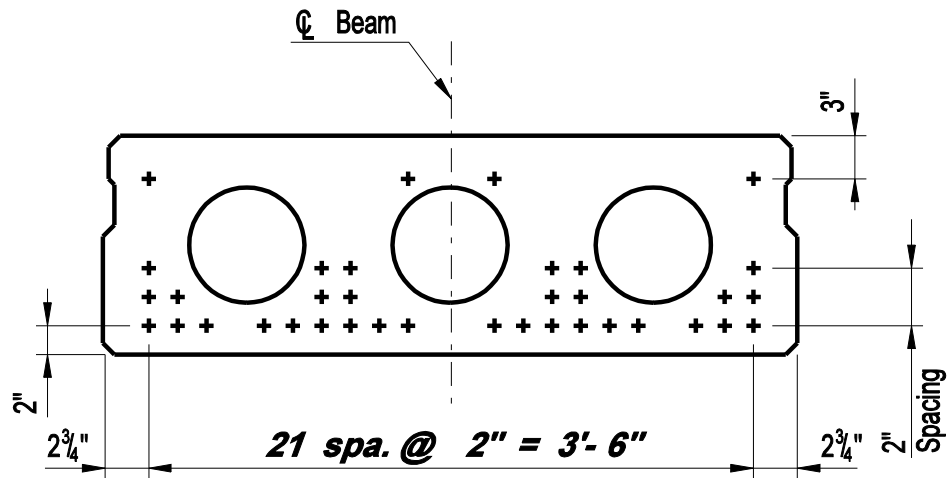
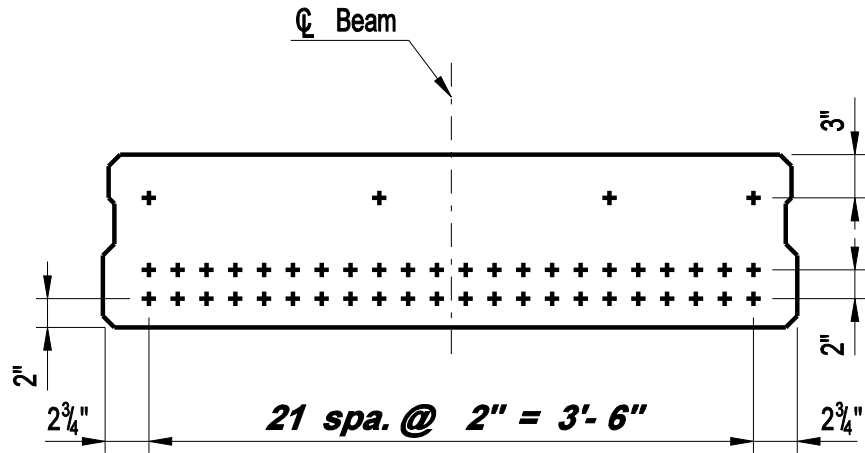

DESIGN INFORMATION

Design Information, see Plate 5.1.7

**CONNECTICUT
BRIDGE DESIGN
MANUAL**

STRAND LOCATIONS
AASHTO CONCRETE SLABS
(S I & S II - 4'- 0" WIDE)

Issue Date: 10/03

Revision Date:

Plate Number:
5.1.5

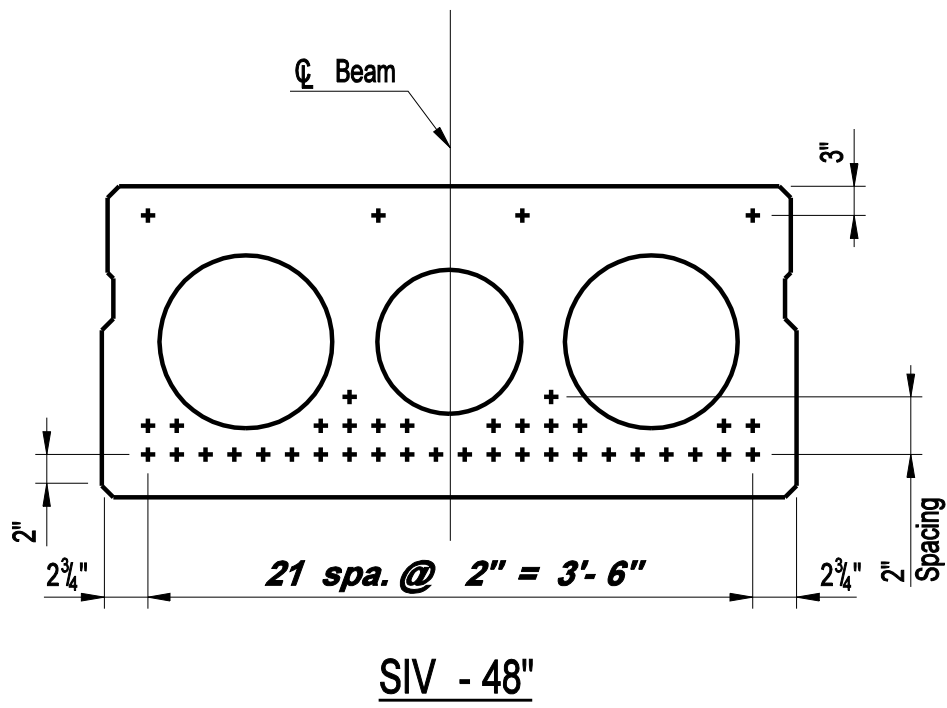
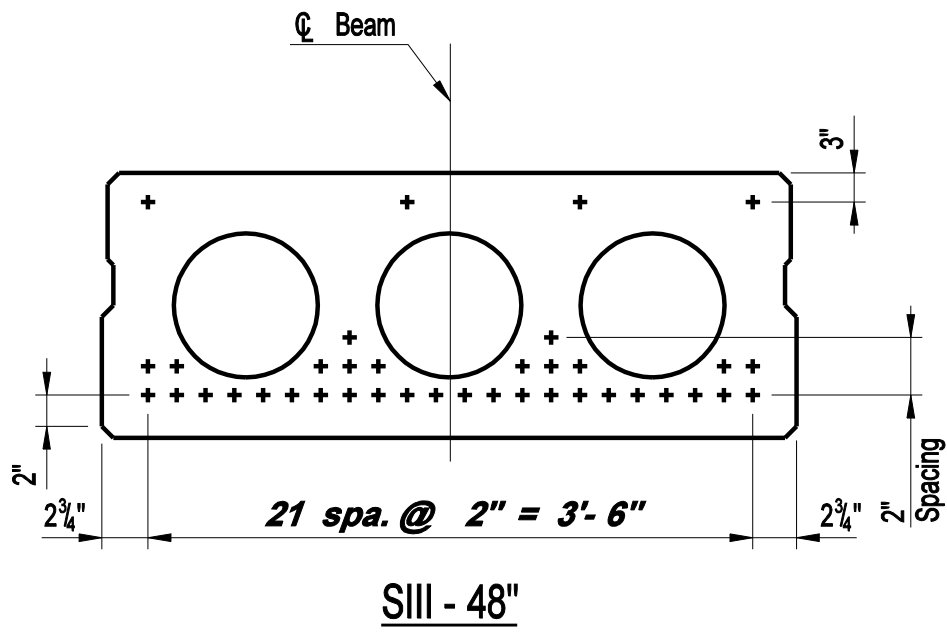

DESIGN INFORMATION

For Design Information, see Plate 5.1.7

CONNECTICUT BRIDGE DESIGN MANUAL	STRAND LOCATIONS AASHTO CONCRETE SLABS (S III & S IV - 4'-0" WIDE)	Issue Date: 10/03
		Revision Date:
		Plate Number: 5.1.6

DESIGN INFORMATION

- 1. The standard strand pattern shown above depicts the maximum number of strands possible that can be located in a given beam while still meeting applicable fabrication clearances and tolerances. For most beam designs, strands shall be placed in as many locations within the pattern as required.**
- 2. + Denotes Prestressing strands**
- 3. Strand locations shown for design purposes only. Final plans shall only show number of strands and center of gravity.**
- 4. For design details, see Plates 5.1.3 - 5.1.6**

**CONNECTICUT
BRIDGE DESIGN
MANUAL**

**STRAND LOCATIONS
AASHTO CONCRETE SLABS
(DESIGN INFORMATION)**

Issue Date: 10/03

Revision Date:

Plate Number:
5.1.7

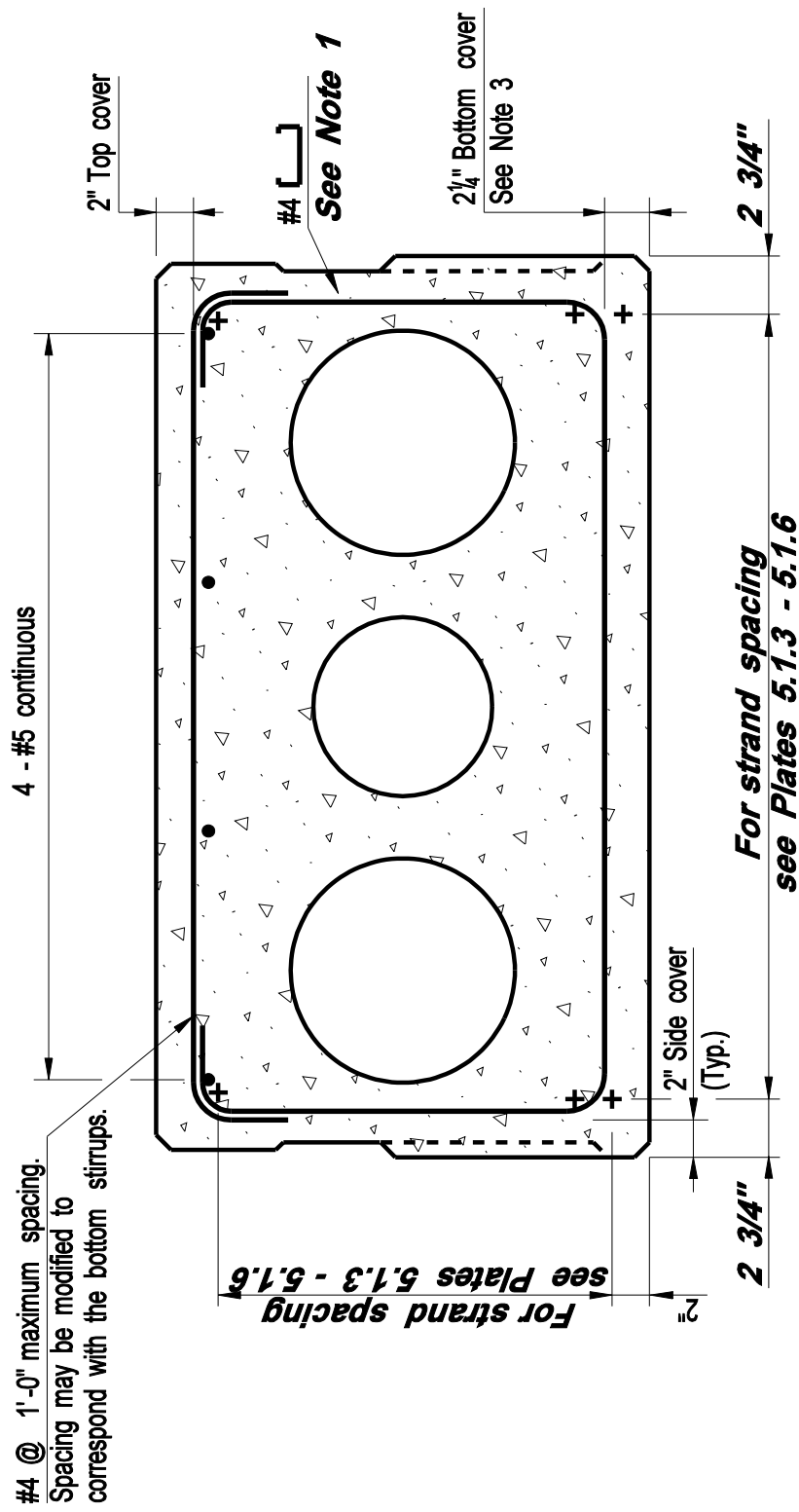

NOTES:

1. This cover is required to facilitate the placement of the bottom prestressing strands. The fabricator may modify cover (1 1/2" min.) if no conflicts exist with the prestressing strands.

DESIGN INFORMATION

1. *Stirrups shall be designed to conform to the requirements of AASHTO. The stirrups shall be #4 bars with a maximum spacing of 12".*

2. *+ Denotes prestressing strands*

∅ 02½" Transverse tie strand hole

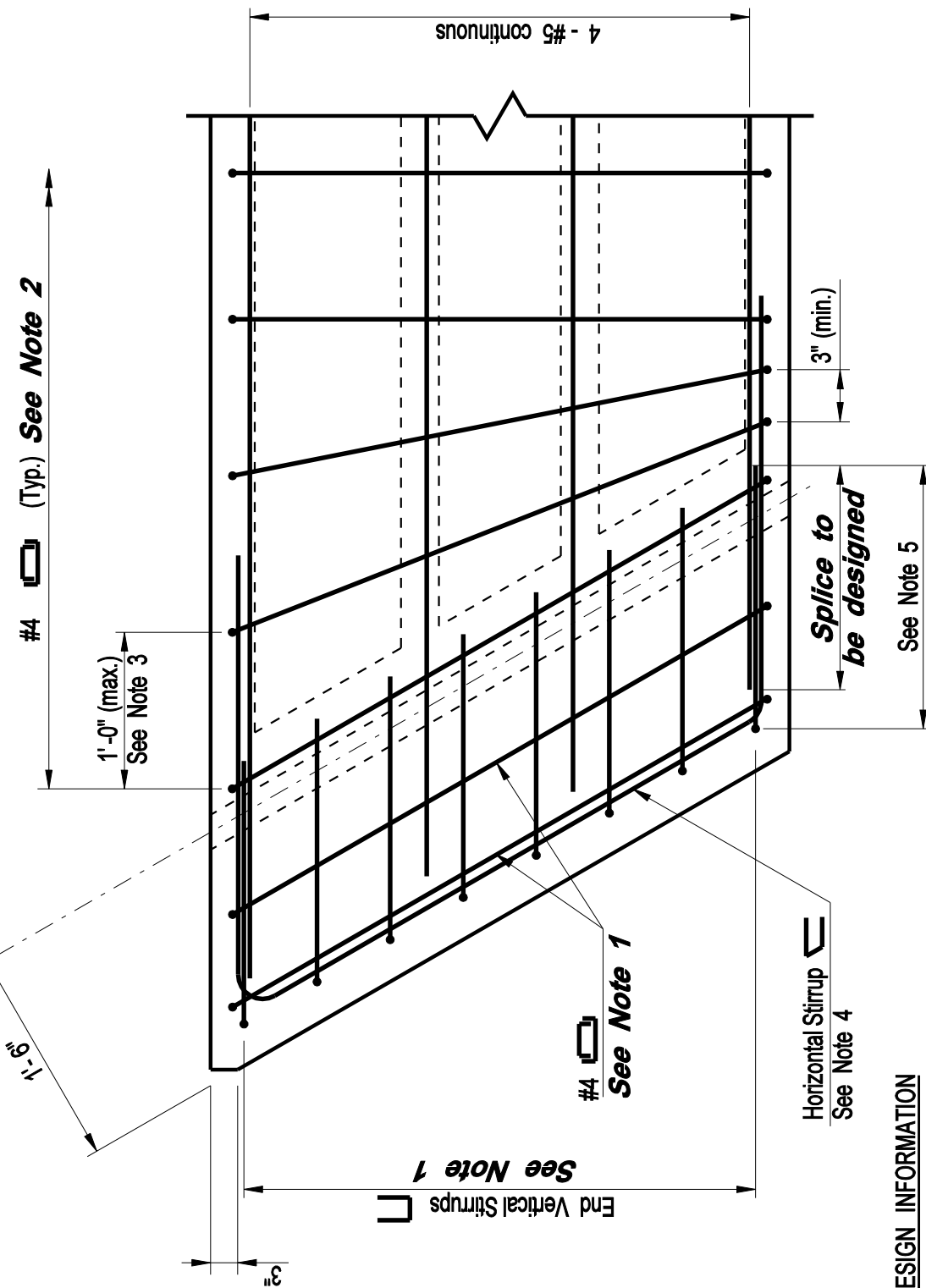

DESIGN INFORMATION

For Notes 1 - 5, See Plate 5.1.9b

PLAN

**CONNECTICUT
BRIDGE DESIGN
MANUAL**

END BLOCK REINFORCING
AASHTO CONCRETE SLABS

Issue Date: 10/03

Revision Date:

Plate Number:
5.1.9a

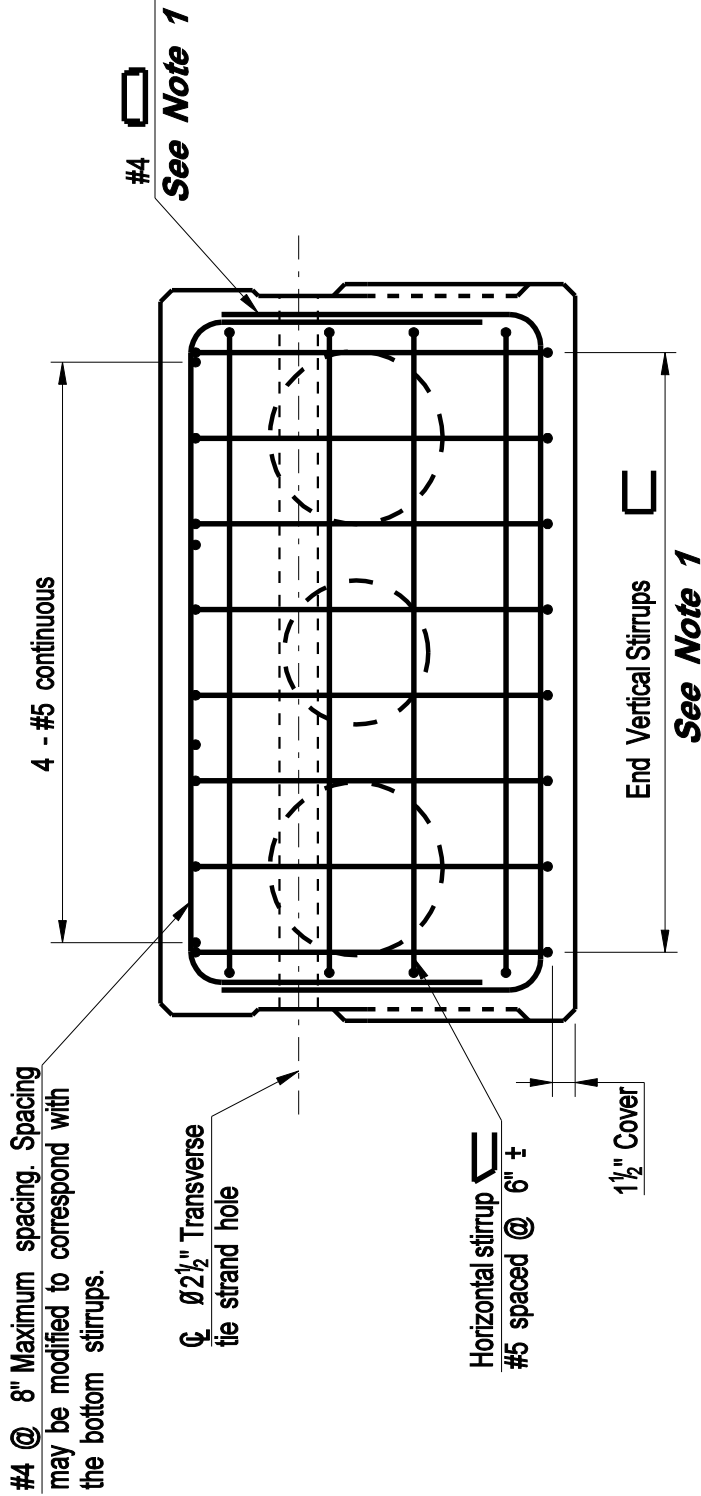

DESIGN INFORMATION

1. *The Engineer shall design the vertical legs of the last transverse stirrup and the end vertical stirrups to satisfy the requirements of AASHTO.*
2. *Stirrups shall be designed to conform to the requirements of AASHTO. The stirrups shall be #4 bars.*

NOTES:

3. Splay stirrups to avoid conflicts with transverse tie strand holes.
4. Extend longitudinal legs a minimum distance equal to the depth of the beam or 12" into the web of the voided section, whichever is larger.
5. Horizontal legs of the vertical stirrups are equal to the depth of the beam.

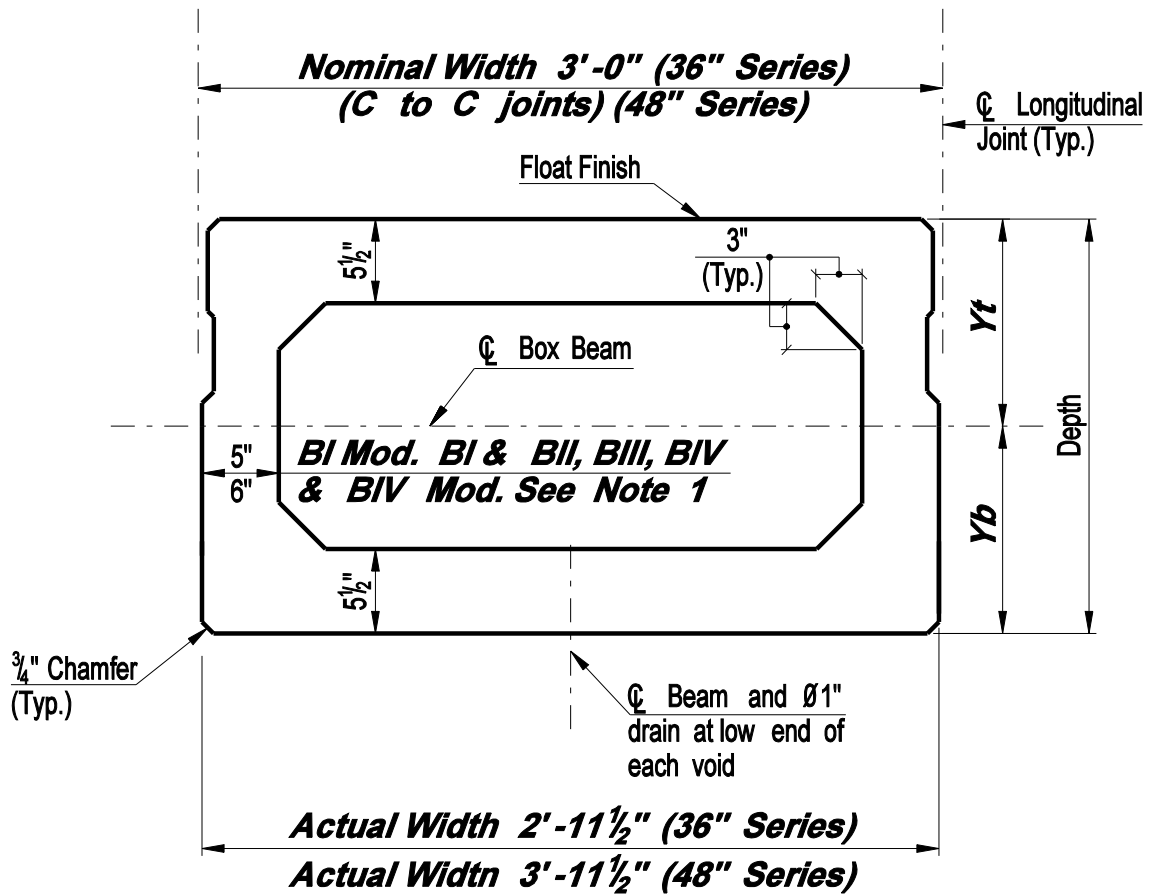

DESIGN INFORMATION

- 5" Web is to accommodate 1 column of draped strands.**
- 6" Web is to accommodate 2 columns of draped strands. For typical strand locations, see Plates 5.2.2 & 5.2.3.**
- 7. Top slab thickness shall be increased to eight inches where necessary to accommodate drilled-in anchors for Temporary Precast Concrete Barrier Curb.**

**CONNECTICUT
BRIDGE DESIGN
MANUAL**

**SECTION PROPERTIES
AASHTO CONCRETE
BOX BEAMS**

Issue Date: 10/03

Revision Date:

Plate Number:

5.2.1a

**CONNECTICUT
BRIDGE DESIGN
MANUAL**

**SECTION PROPERTIES
AASHTO CONCRETE
BOX BEAMS**

BEAM TYPE	Width		Depth	A (<i>inch</i> ²)	I (<i>inch</i> ⁴)	Y _b (<i>in.</i>)	Y _t (<i>in.</i>)	S _b (<i>inch</i> ³)	S _t (<i>inch</i> ³)	Wt. (<i>lb/ft</i>)
	Nom. (<i>inch</i>)	Act. (<i>inch</i>)								
<i>BI-36 Mod.</i>	36.0	35.5	24.0	524.6	36136	11.87	12.13	3043	2980	546
<i>BI-48 Mod.</i>	48.0	47.5	24.0	656.6	47764	11.90	12.10	4014	3947	684
<i>BI-36</i>	36.0	35.5	27.0	554.6	49495	13.35	13.65	3709	3625	578
<i>BI-48</i>	48.0	47.5	27.0	686.6	65085	13.38	13.62	4886	4777	715
<i>BII-36</i>	36.0	35.5	33.0	614.6	83834	16.30	16.70	5144	5019	640
<i>BII-48</i>	48.0	47.5	33.0	746.6	109127	16.33	16.67	6681	6548	778
<i>BIII-36</i>	36.0	35.5	39.0	730.6	132895	19.28	19.72	6894	6738	761
<i>BIII-48</i>	48.0	47.5	39.0	862.6	170267	19.31	19.69	8817	8648	899
<i>BIV-36</i>	36.0	35.5	42.0	766.6	161387	20.76	21.24	7773	7599	799
<i>BIV-48</i>	48.0	47.5	42.0	898.6	205690	20.80	21.20	9890	9701	936
<i>BIV-36 Mod.</i>	36.0	35.5	45.0	802.6	193328	22.25	22.75	8689	8498	836
<i>BIV-48 Mod.</i>	48.0	47.5	45.0	834.6	245156	22.29	22.72	11001	10793	974

DESIGN INFORMATION

1. Weight of beam does not include weight of solid sections at transverse ties. Use the total weight (including solid sections) for design.
2. Thickness of top flange may have to be increased to develop sidewalk/parapet reinforcement. See Section 5.6. The designer shall calculate and use the Modified Properties in this case.

Issue Date: 10/03

Revision Date:

Plate Number:

5.2.1b

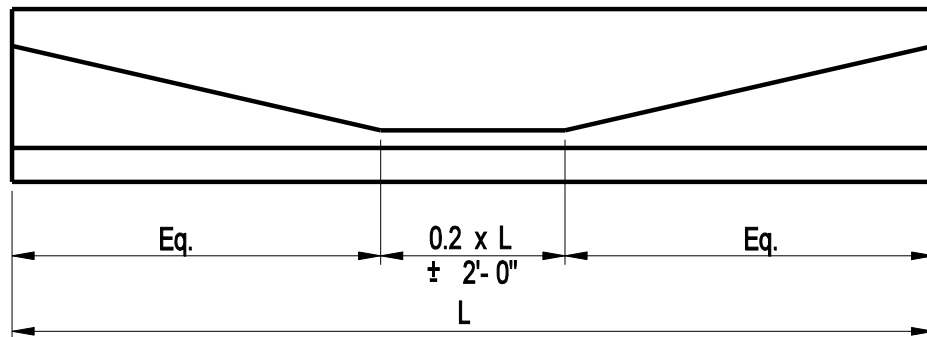

HOLD DOWN POINTS FOR DRAPED STRANDS

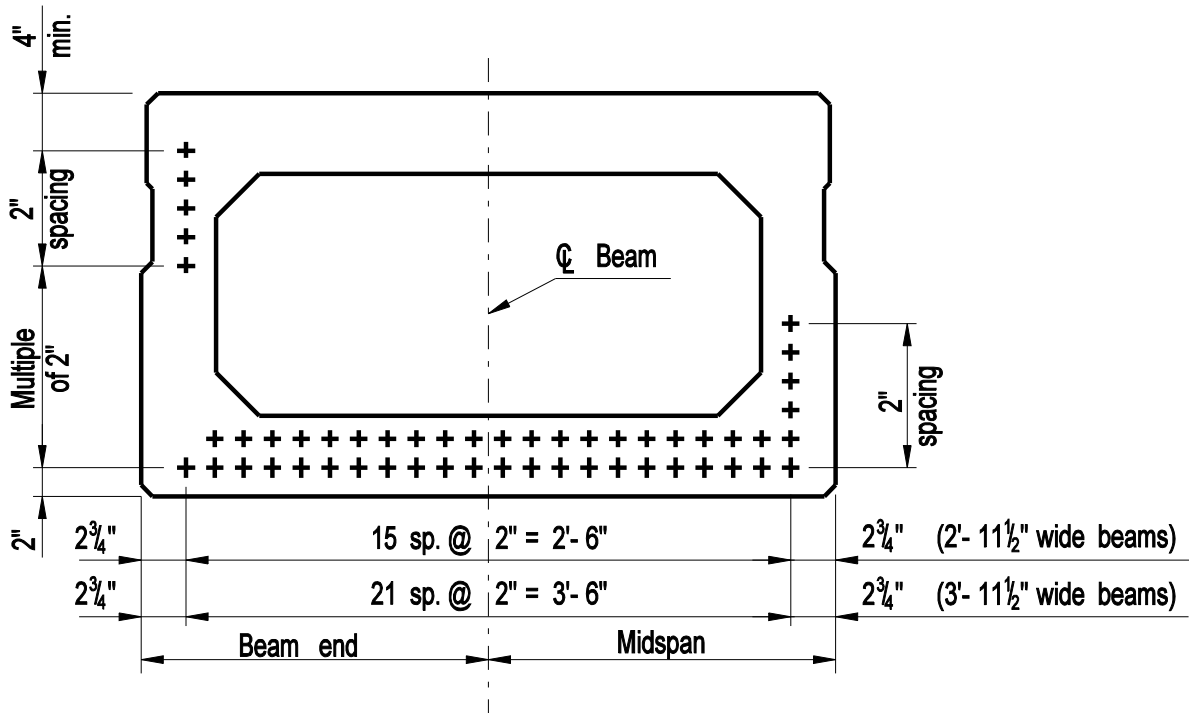

STRAND LOCATIONS

DESIGN INFORMATION

1. *The standard strand pattern shown above depicts the maximum number of strands possible that can be located in a given beam while still meeting applicable fabrication clearances and tolerances. For most beam designs, strands shall be placed in as many locations within the pattern as required.*
2. *+ Denotes Prestressing strands*
3. *Strand locations shown for design purposes only. Final plans shall only show number of strands and center of gravity.*

**CONNECTICUT
BRIDGE DESIGN
MANUAL**

**STRAND LOCATIONS
AASHTO BOX BEAMS
(TYPE B I, B I MODIFIED & B II)**

Issue Date: 10/03

Revision Date:

Plate Number:
5.2.2

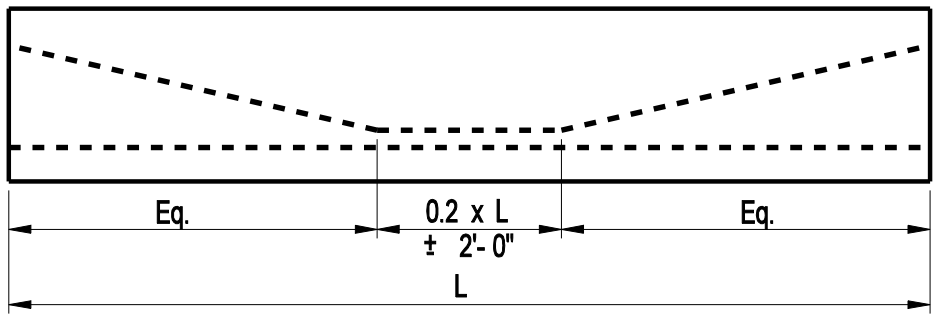

HOLD DOWN POINTS
FOR DRAPED STRANDS

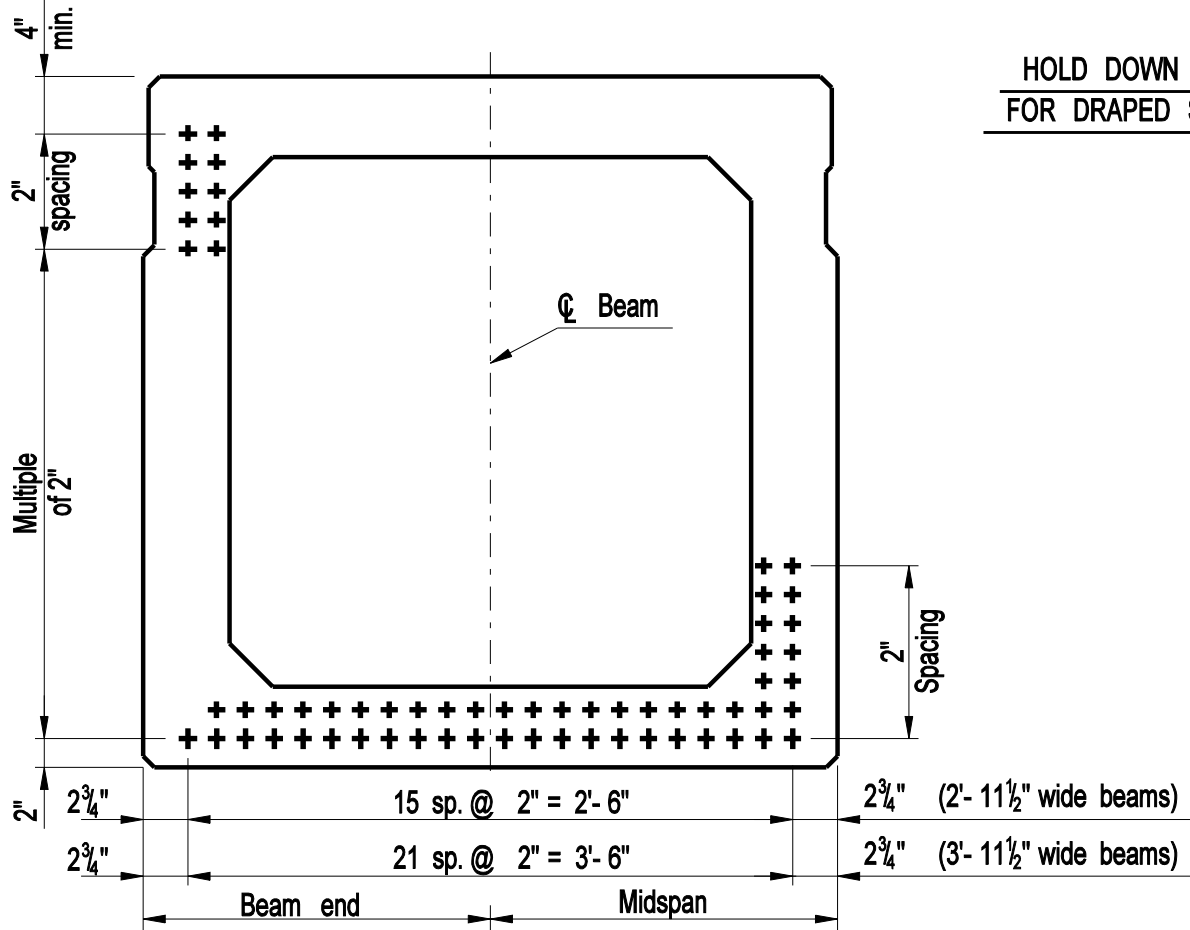

STRAND LOCATION

DESIGN INFORMATION

1. The standard strand pattern shown above depicts the maximum number of strands possible that can be located in a given beam while still meeting applicable fabrication clearances and tolerances. For most beam designs, strands shall be placed in as many locations within the pattern as required.
2. + Denotes Prestressing strands
3. Strand locations shown for design purposes only. Final plans shall only show number of strands and center of gravity.

**CONNECTICUT
BRIDGE DESIGN
MANUAL**

**STRAND LOCATIONS
AASHTO BOX BEAMS
(TYPE B III, B IV & B IV MODIFIED)**

Issue Date: 10/03

Revision Date:

Plate Number:
5.23

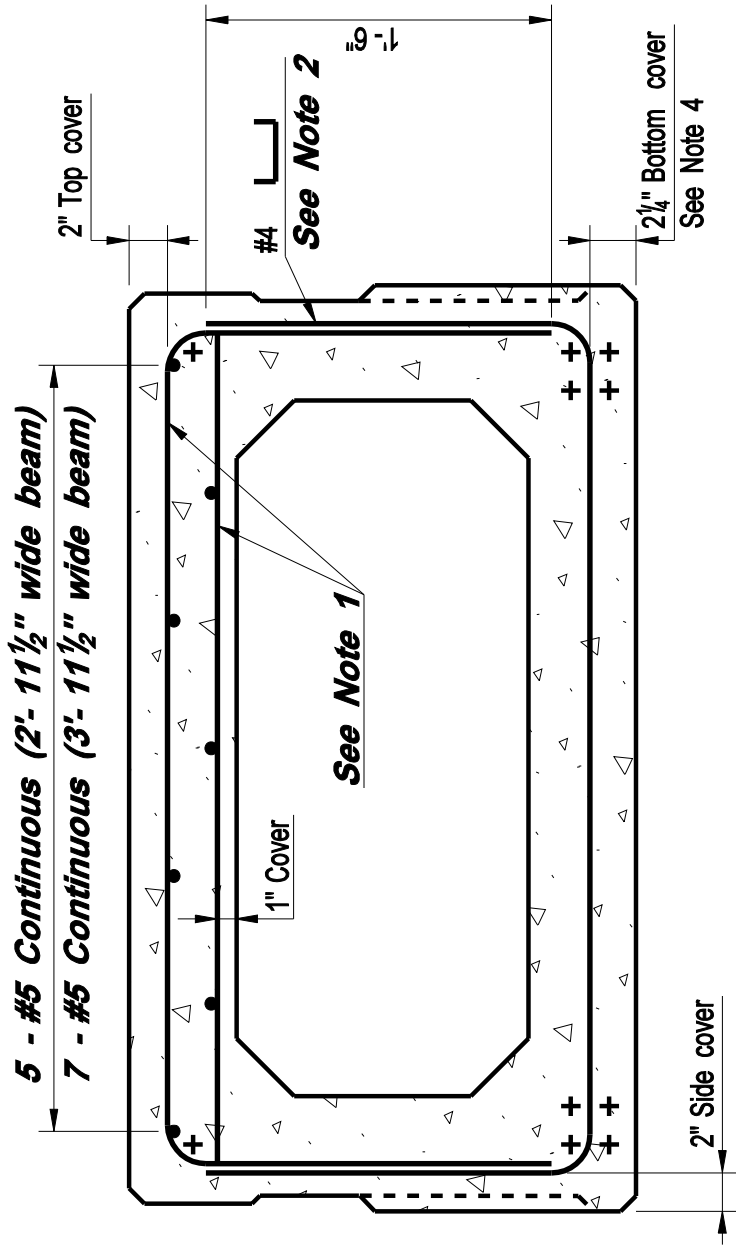

DESIGN INFORMATION

1. Use #4 or #5 bars only for the top transverse stirrups and slab reinforcement. Spacing shall not exceed 8".
2. Bottom transverse stirrups shall be placed at a multiple of the top bar spacing with a maximum spacing of 1'- 4".
3. + Denotes prestressed strand.

NOTES:

4. This cover is required to facilitate the placement of the bottom prestressing strands. The fabricator may modify cover (1 1/2" min.) if no conflicts exist with the prestressing strands.

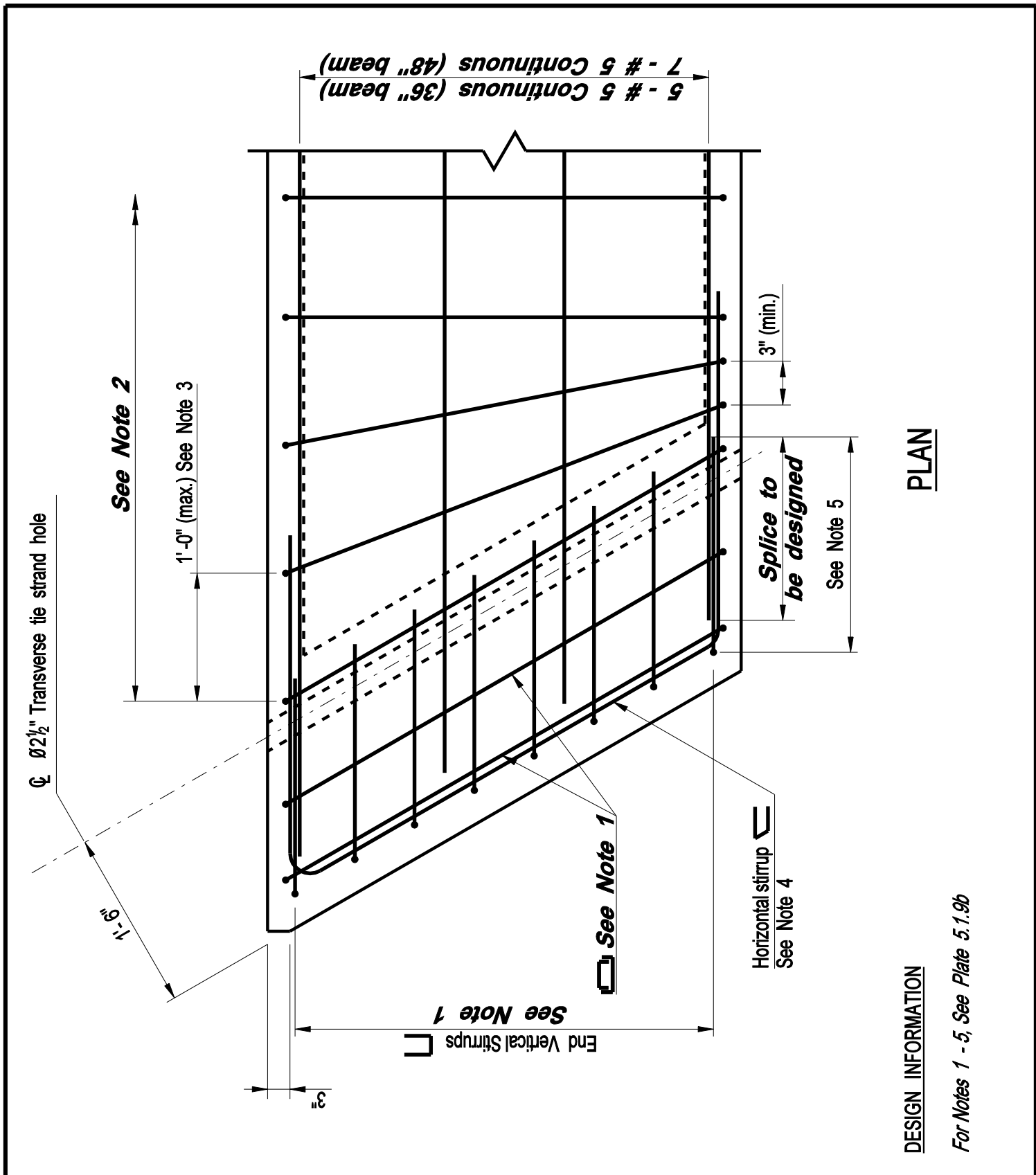

PLAN

DESIGN INFORMATION

For Notes 1 - 5, See Plate 5.1.9b

**CONNECTICUT
BRIDGE DESIGN
MANUAL**

**END BLOCK REINFORCING
AASHTO BOX BEAMS**

Issue Date: 10/03

Revision Date:

Plate Number:
5.2.5a

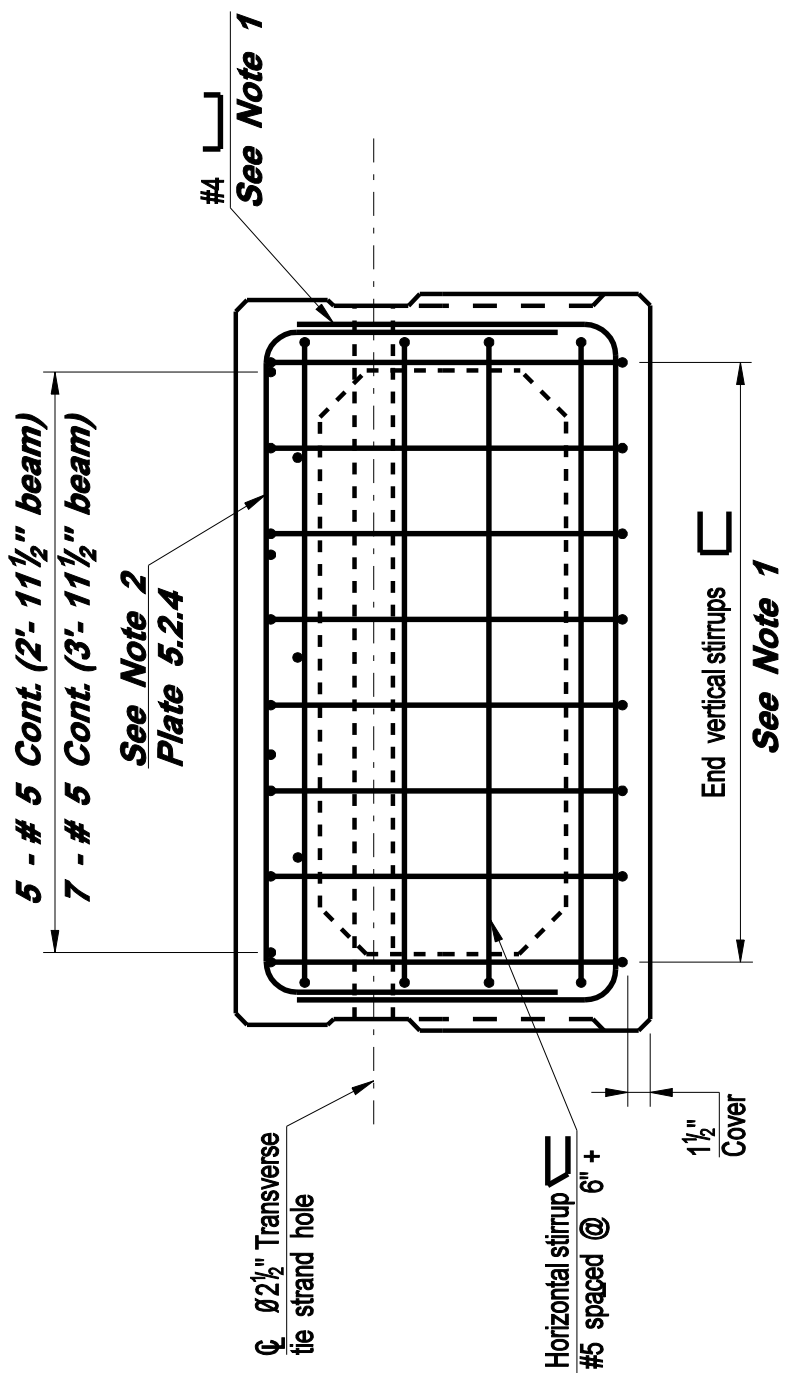

END VIEW

DESIGN INFORMATION

- 1. The Engineer shall design the vertical legs of the last transverse stirrup and the end vertical stirrups to satisfy the requirements of AASHTO.*
- 2. Stirrups shall be designed to conform to the requirements of AASHTO.*

NOTES:

- Splay stirrups to avoid conflicts with transverse tie strand holes.
- Extend longitudinal legs a minimum distance equal to the depth of the beam or 12" into the web of the voided section, whichever is larger.
- Horizontal legs of the vertical stirrups are equal to the depth of the beam.

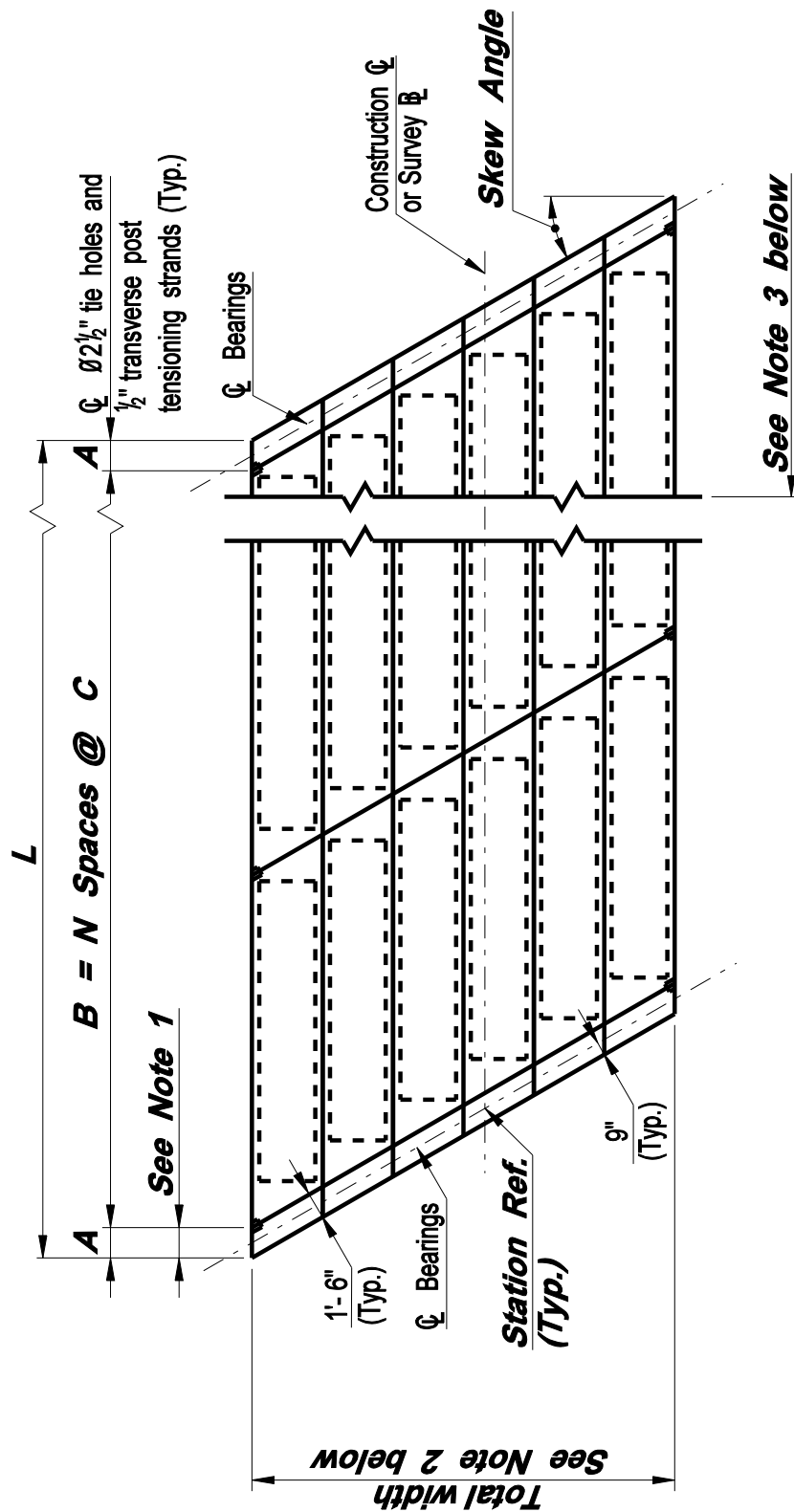

DESIGN INFORMATION

1. $A = 18" / \cos(\text{Skew angle})$
 $B = L - (2xA)$
 $C = B/N$ where $N = \text{Number of Internal voids. (See Plate No. 5.3.7 for the required number of transverse ties.)}$
2. Total width shall be calculated using 4'-0" for 48" series nominal units and 3'-0" for 36" series nominal units.
3. Framing plan shall be drawn full length without breaks and to scale on the construction plans. Show all internal voids, transverse ties and include North arrow.

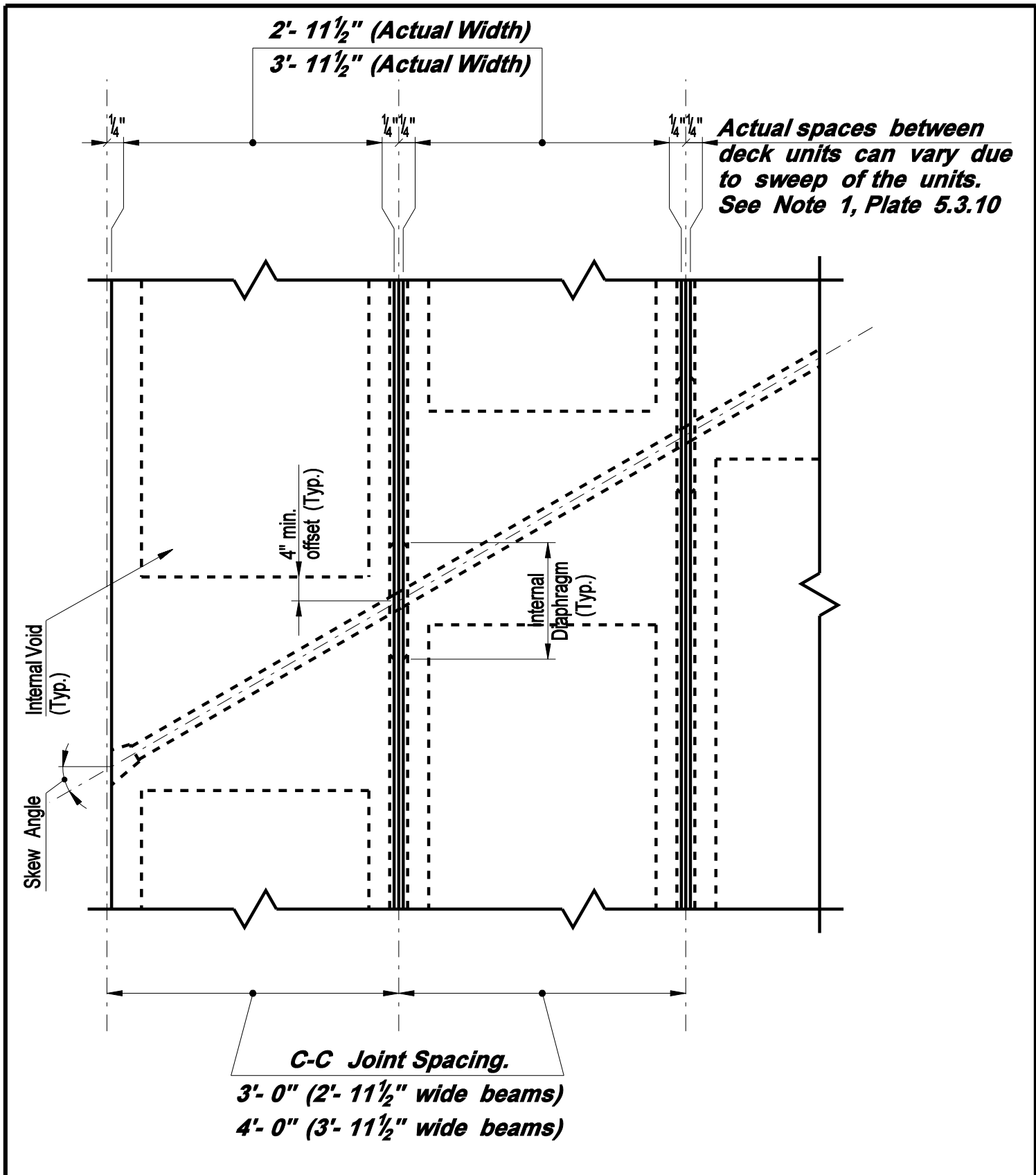

**FRAMING PLAN WITH STAGE
CONSTRUCTION - PRECAST
CONCRETE DECK UNITS
(SKEW $\leq 35^\circ$)**

Issue Date: 10/03

Revision Date:

Plate Number:
5.3.3

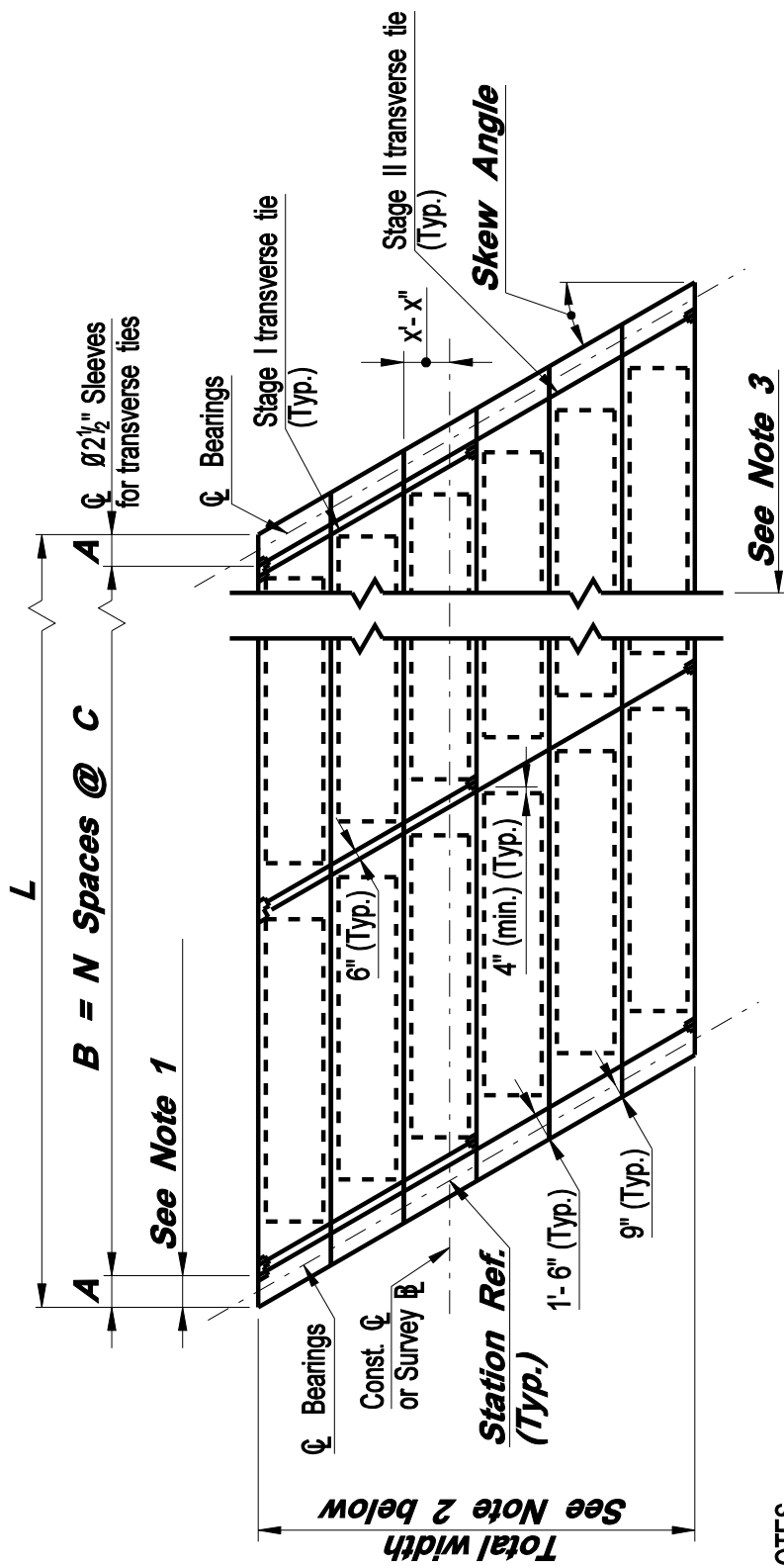

NOTES

Stage I: After erecting Stage I beams, install and tension transverse ties in Stage I sleeves.

Stage II: After erecting Stage II beams, install and tension transverse ties in Stage II sleeves full width of bridge.

DESIGN INFORMATION

1. $A = 18'' / \cos$ skew angle

$B = L - (2xA)$

$C = B/N$ where N = Number of Internal voids. (See Plate No. 5.3.7 for the required number of transverse ties.)

$L = \text{Span Length} + A$

2. Total width shall be calculated using 4'-0" for 48" series nominal units and 3'-0" for 36" series nominal units.

3. Framing plan shall be drawn full length without breaks and to scale on the construction plans. Show all internal voids, transverse ties and include North arrow.

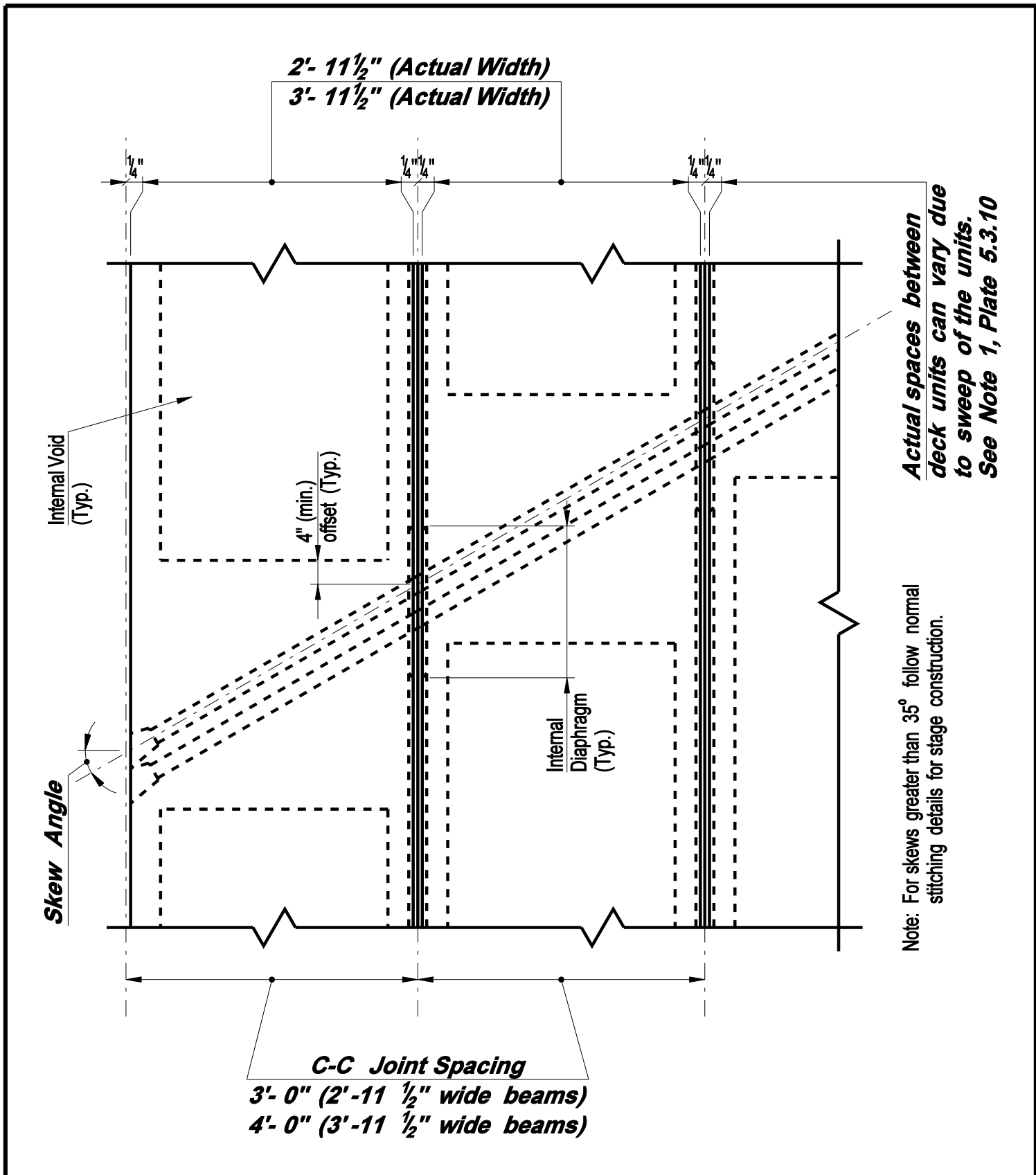

**FRAMING PLAN - PRECAST
CONCRETE DECK UNITS
(SKEW > 35°)**

Issue Date:	10/03
Revision Date:	
Plate Number:	5.3.5

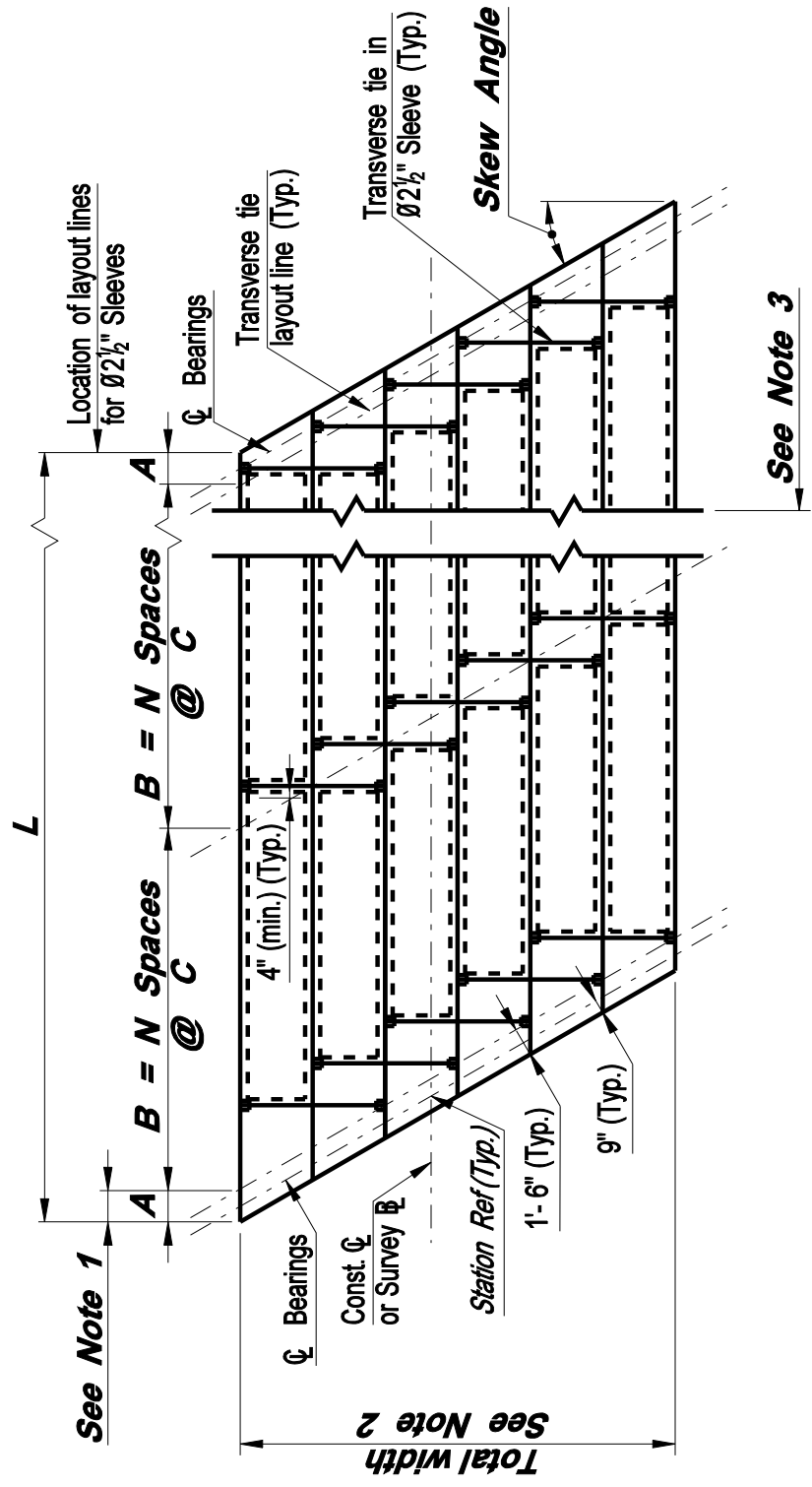

DESIGN INFORMATION

1. $A = 18'' / \cos \text{skew angle}$
 $B = L - (2xA)$
 $C = B/N$ where $N = \text{Number of Internal Voids.}$ (See Plate No. 5.3.7 for the required number of transverse ties.)
 $L = \text{Span Length} + A$
2. Total width shall be calculated using 4'-0" for 48" series nominal units and 3'-0" for 36" series nominal units.
3. Framing plan shall be drawn full length without breaks and to scale on the construction plans. Show all internal voids, transverse ties and include North arrow.

See Note 3

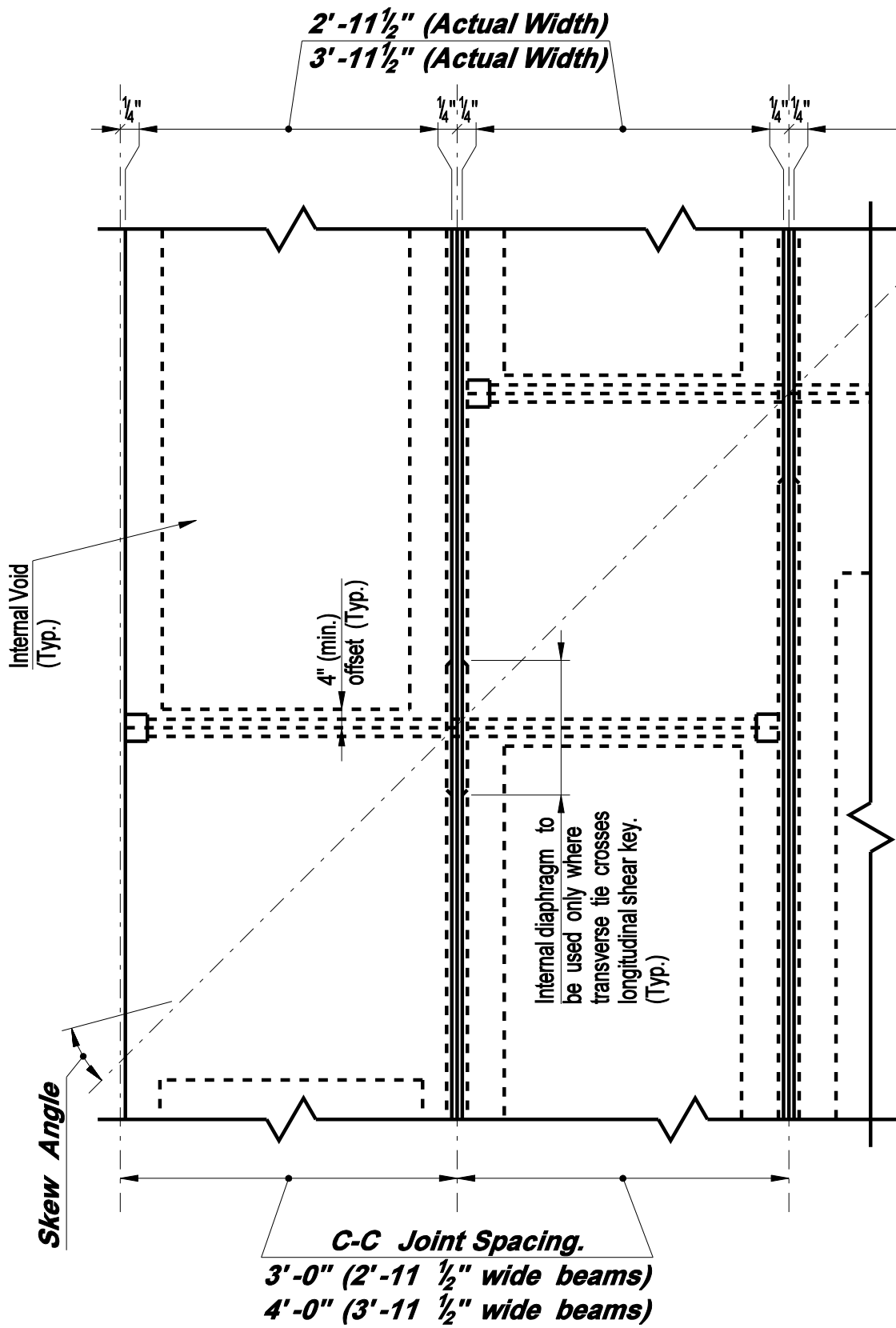

Actual spaces between deck units can vary due to sweep of the units. See Note 1, Plate 5.3.10

NOTES:
For skews greater than 35° follow normal stitching details for stage construction.

**CONNECTICUT
BRIDGE DESIGN
MANUAL**

**TRANSVERSE TIE STRAND
ARRANGEMENT FOR PRECAST
CONCRETE DECK UNITS
(SKEW > 35°)**

Issue Date: 10/03

Revision Date:

Plate Number:
5.3.6

PRECAST CONCRETE VOIDED SLABS							
BEAM	SPANS	TIE LOCATIONS			TOP	BOTTOM	
		ENDS	1/3 POINTS	MIDSPAN		SKEW $\geq 25^\circ$ or STITCHED BEAMS	SKEW $\geq 25^\circ$
<i>SI Thru SIV</i>	$\leq 40'-0''$	X		X	X		X
	$> 40'-0''$	X	X		X		X

PRECAST CONCRETE BOX BEAMS								
BEAM	SPANS	TIE LOCATIONS				TOP	BOTTOM	
		ENDS	1/4 POINTS	1/3 POINTS	MIDSPAN		SKEW $\leq 25^\circ$ or STITCHED BEAMS	SKEW $\geq 25^\circ$
<i>BI & BI Mod.</i>	$\leq 50'-0''$	X			X	X		X
	$> 50'-0''$	X		X		X		X
<i>BII</i>	$\leq 75'-0''$	X		X		X		X
	$> 75'-0''$	X	X			X		X
<i>BIII</i>	$\leq 75'-0''$	X				X	X	X
	$> 75'-0''$	X	X			X	X	X
<i>BIV & BIV Mod.</i>	ALL	X	X		X	X	X	X

NOTE:

The designer shall investigate the fascia beam for torsional load due to parapet overhang or utilities. Consideration shall be given to increasing the number of lateral tie strands, the amount of post-tensioning and/or providing additional internal diaphragms.

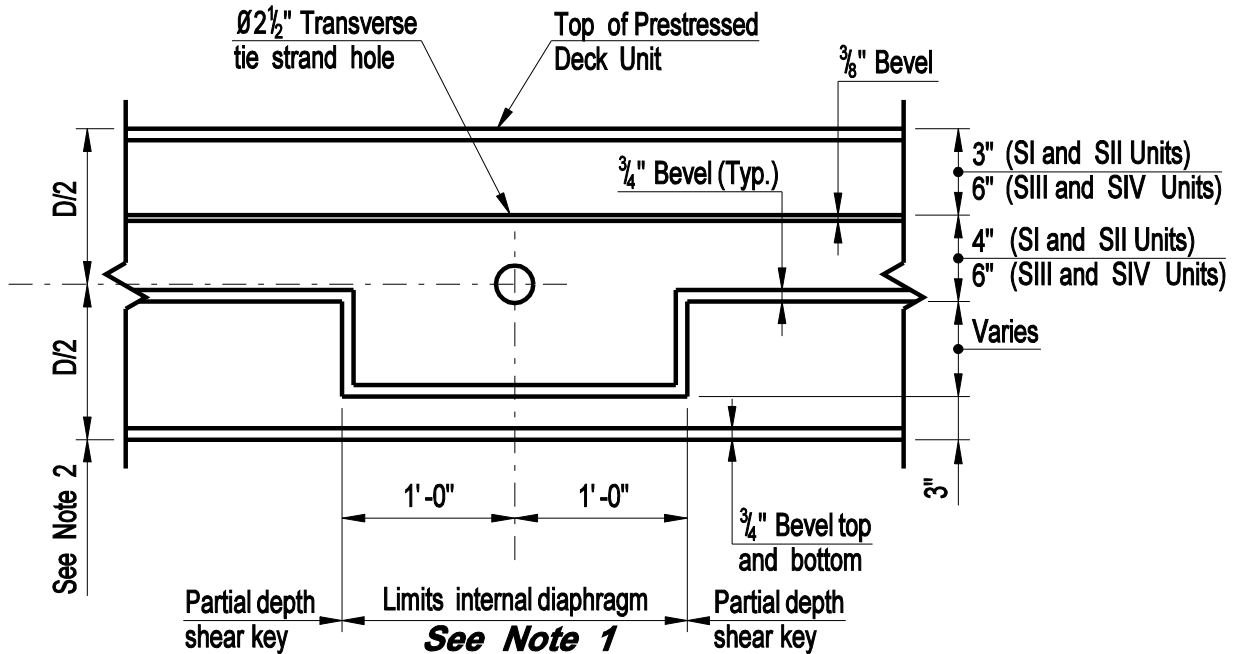

DESIGN INFORMATION

1. If two sets of post-tensioning strands are used for stage construction, the width of the internal diaphragm shall be increased to 2'- 0" plus the longitudinal spacing of the two tie strand holes.

NOTES:

2. The vertical location of the transverse tie strands must be coordinated with the location of the prestressed strands and adjusted as necessary by the fabricator.

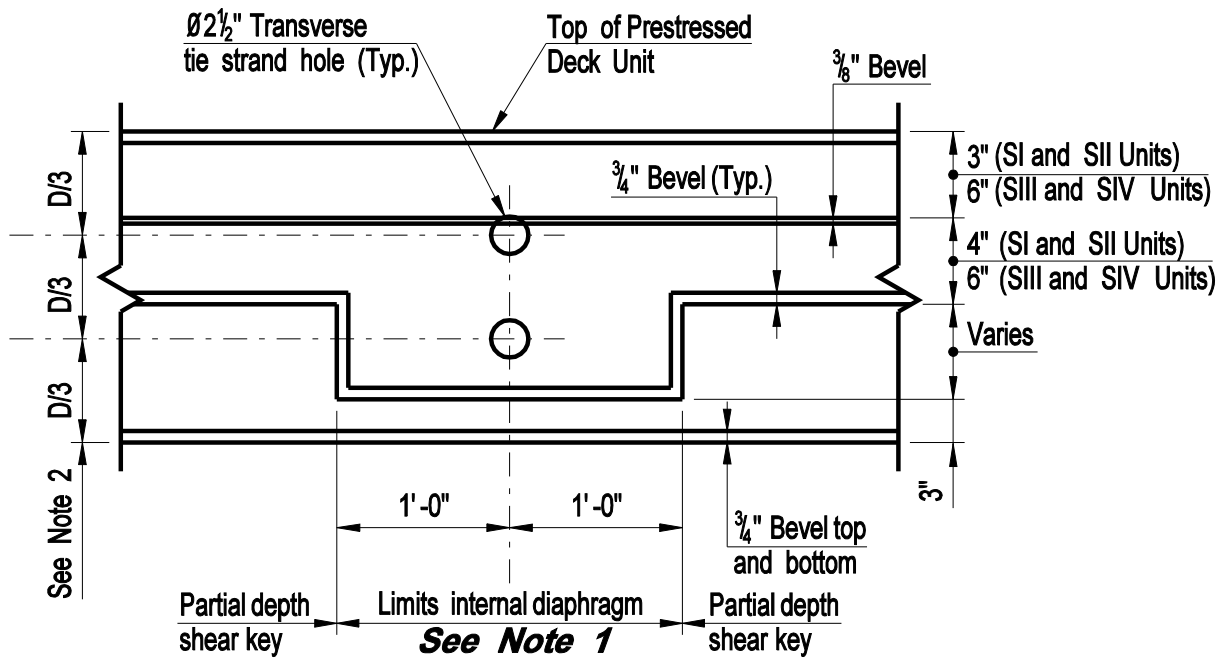

DESIGN INFORMATION

1. If two sets of post-tensioning strands are used for stage construction, the width of the internal diaphragm shall be increased to 2'- 0" plus the longitudinal spacing of the two tie strand holes.

NOTES:

2. The vertical location of the transverse tie strands must be coordinated with the location of the prestressed strands and adjusted as necessary by the fabricator.

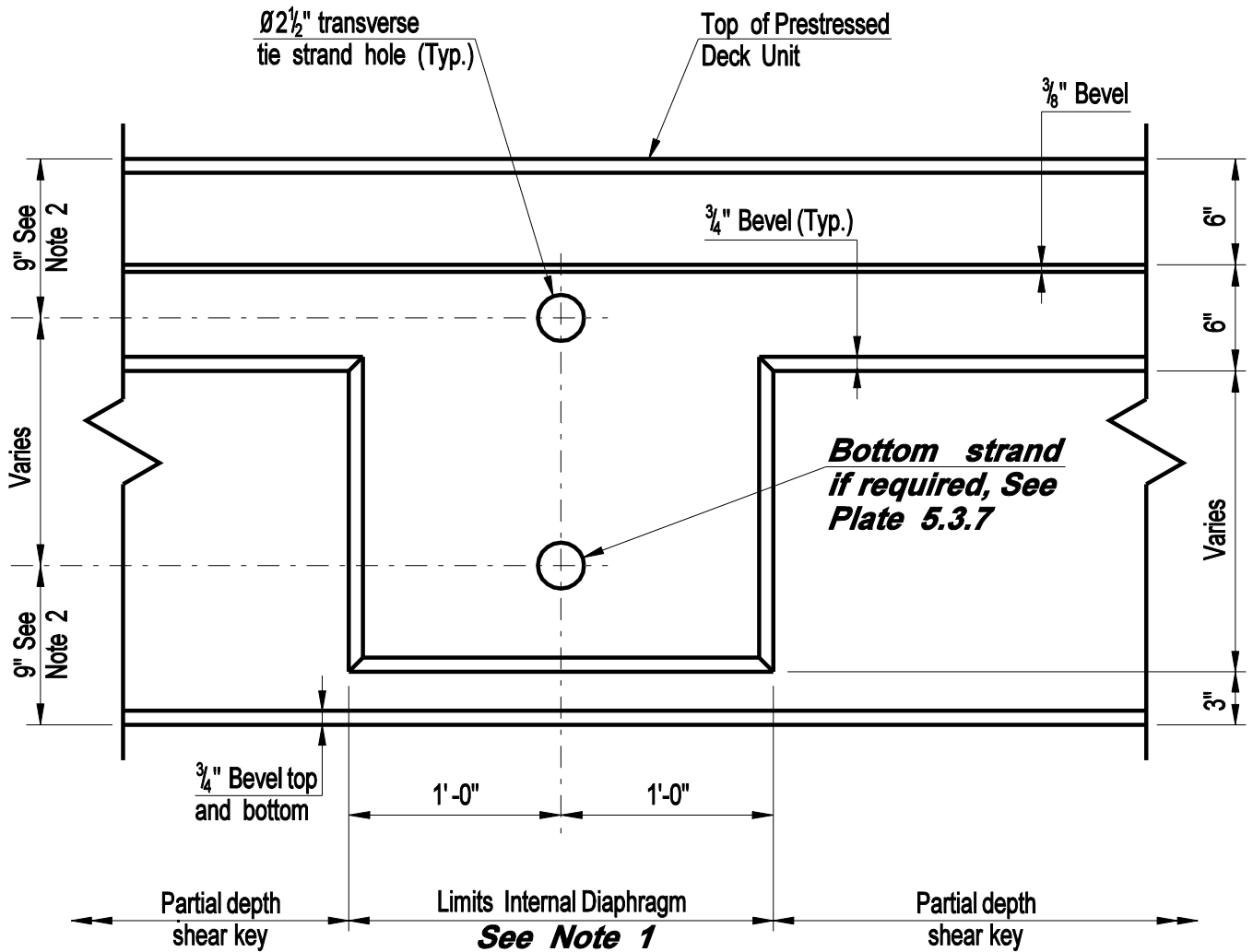

DESIGN INFORMATION

1. If two sets of post-tensioning strands are used for stage construction, the width of the internal diaphragm shall be increased to 2'- 0" plus the longitudinal spacing of the two tie strand holes.

NOTES:

2. The vertical location of the transverse tie strands must be co-ordinated with the location of the prestressed strands and adjusted as necessary by the fabricator.

**CONNECTICUT
BRIDGE DESIGN
MANUAL**

**INTERNAL DIAPHRAGMS
PRECAST CONCRETE
BOX BEAMS**

Issue Date: 10/03

Revision Date:

Plate Number:

5.3.10

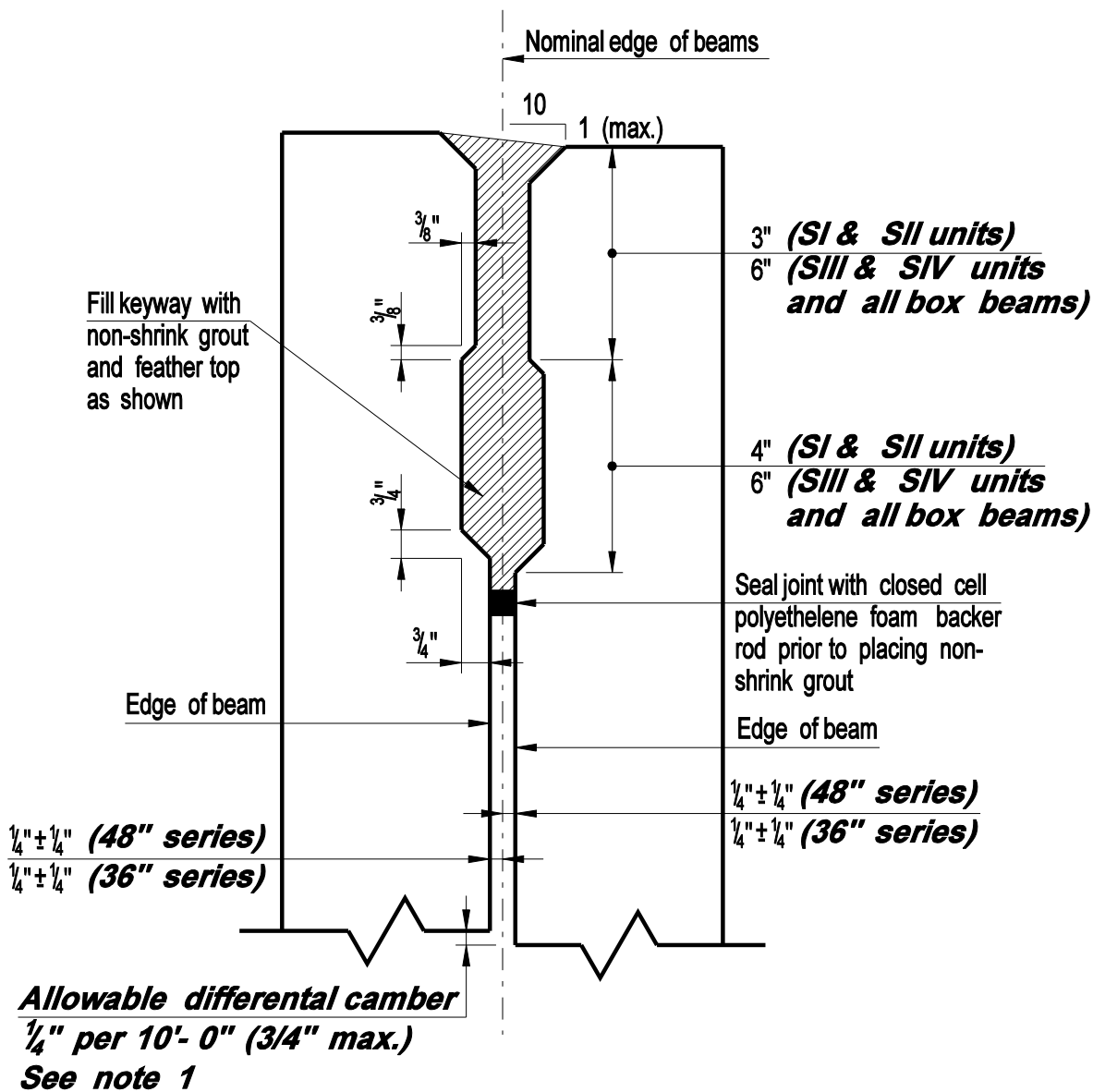

DESIGN INFORMATION

1. The variation indicated is due to fabrication tolerances for sweeps and camber of the deck units.

NOTES:

- 2. The deck units shall be placed at the nominal spacing shown on the plan with a gap between the units. The width of the gaps will vary due to the sweep of the units.
- 3. Grout for shear keys shall be rodded or vibrated to ensure that all voids in the shear keys are filled.

**CONNECTICUT
BRIDGE DESIGN
MANUAL**

VACANT

Issue Date: 10/03

Revision Date:

Plate Number:
5.3.12

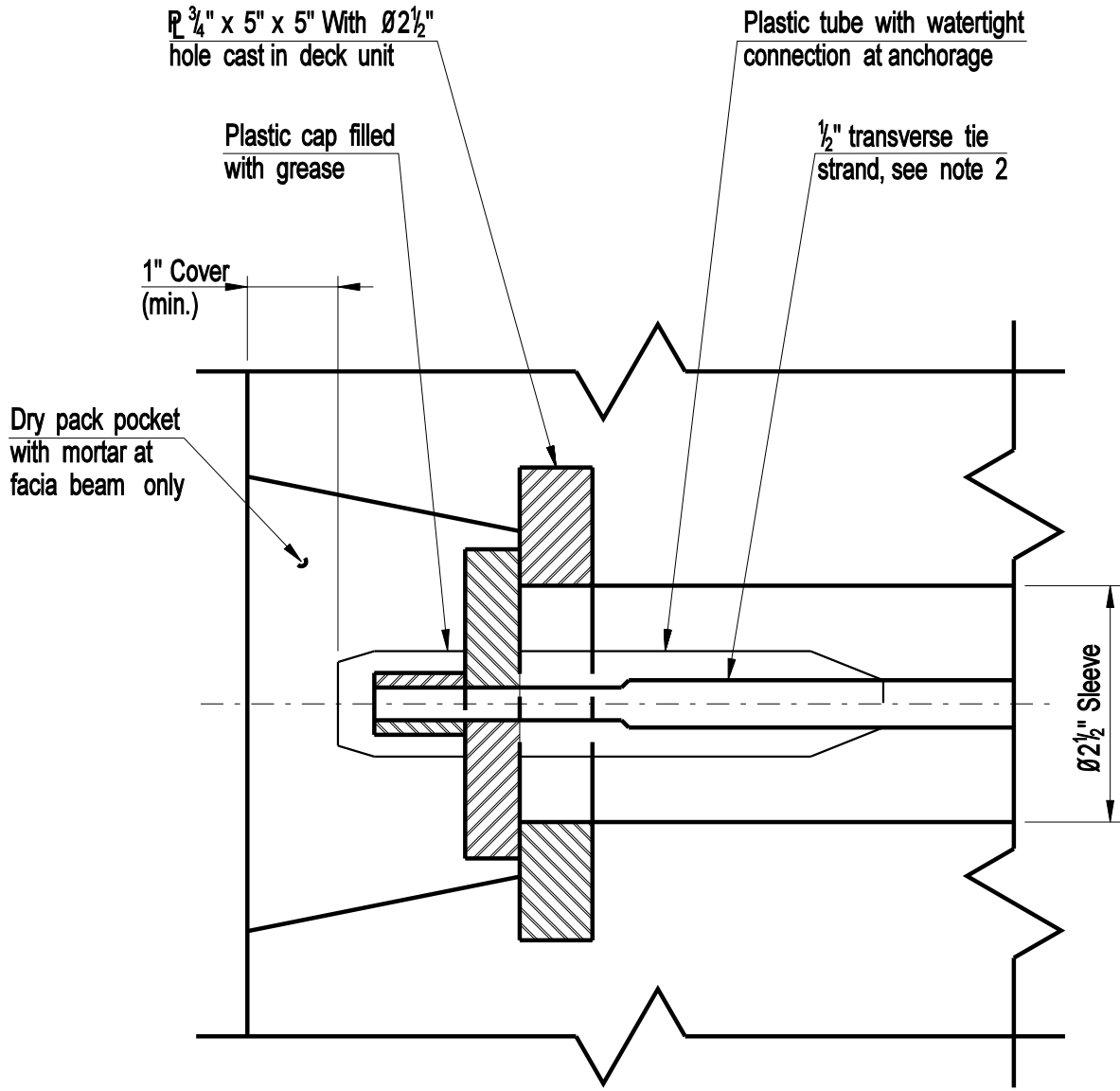

TRANSVERSE TIE POCKET DETAIL

NOTES:

1. Other anchorage systems may be substituted with the approval of the Engineer. Alternate anchorage systems shall be wirtight and corrosion proof.
2. Transverse ties shall be covered by a seamless polypropylene sheath, with corrosion inhibiting grease between the strand and sheath, for the full length of the strand except at the anchorage location.

**CONNECTICUT
BRIDGE DESIGN
MANUAL**

**TRANSVERSE TIE ANCHORAGE
PRECAST CONCRETE
DECK UNITS**

Issue Date: 10/03

Revision Date:

Plate Number:
5.3.13

FOR SKEWS $\leq 35^\circ$:

TRANSVERSE TIE TENSIONING NOTES:

1. After all beams have been erected, tension each transverse tie to 5 kips.
2. Fill all keyways with non-shrink grout. The contractor shall cover and protect the keyways from the weather and debris until they are filled.
3. After the grout has attained a strength of 1500 psi (based on the manufacturers directions) tension each transverse tie to 30 kips. No traffic or heavy equipment will be permitted on the beams until all ties have been fully tensioned.

(The above note applies to units with single transverse ties. See Plate 5.3.7)

After the grout has attained a strength of 1500 psi (based on the manufacturers directions) at each transverse tie location, tension the bottom tie to 15 kips, then the top tie to 15 kips. Repeat the sequence once more so that each strand has 30 kips of tension. No traffic or heavy equipment will be permitted on the beams until all ties have been fully tensioned.

(The above note applies to units with double transverse ties. See Plate 5.3.7)

4. Concrete for sidewalk, curb and/or barrier sections shall not be placed until the transverse ties have been fully tensioned.

FOR SKEWS > 35°:
TRANSVERSE TIE TENSIONING NOTES:

1. As each beam is being erected, install the transverse ties with hardwood wedges between the beams at each transverse tie location at the top and bottom of the beam.
2. Secure each beam to the preceding beam by tensioning each transverse tie to 30 kips before erecting the next beam.

***(The above note applies to units with single transverse ties.
See Plate 5.3.7)***

Secure each beam to the preceding beam by first tensioning the bottom tie at each transverse tie location to 15 kips, then the top tie to 15 kips. Repeat the sequence once more so that each tie has 30 kips of tension before erecting the next beam.

***(The above note applies to units with double transverse ties.
See Plate 5.3.7)***

3. Fill all keyways with non-shrinking grout after transverse ties have been tensioned. The contractor shall cover and protect the keyways from the weather and debris until they are filled. No traffic or heavy equipment will be permitted on the beams until all keyways have been filled and the grout has cured.
4. When the grout has attained a strength of 1500 psi (based on grout manufacturers directions) the wedges shall be removed and voids left by the top wedges shall be filled with grout.
5. Concrete for sidewalk, curb and/or barrier sections shall not be placed until grout has attained a strength of 1500 psi.

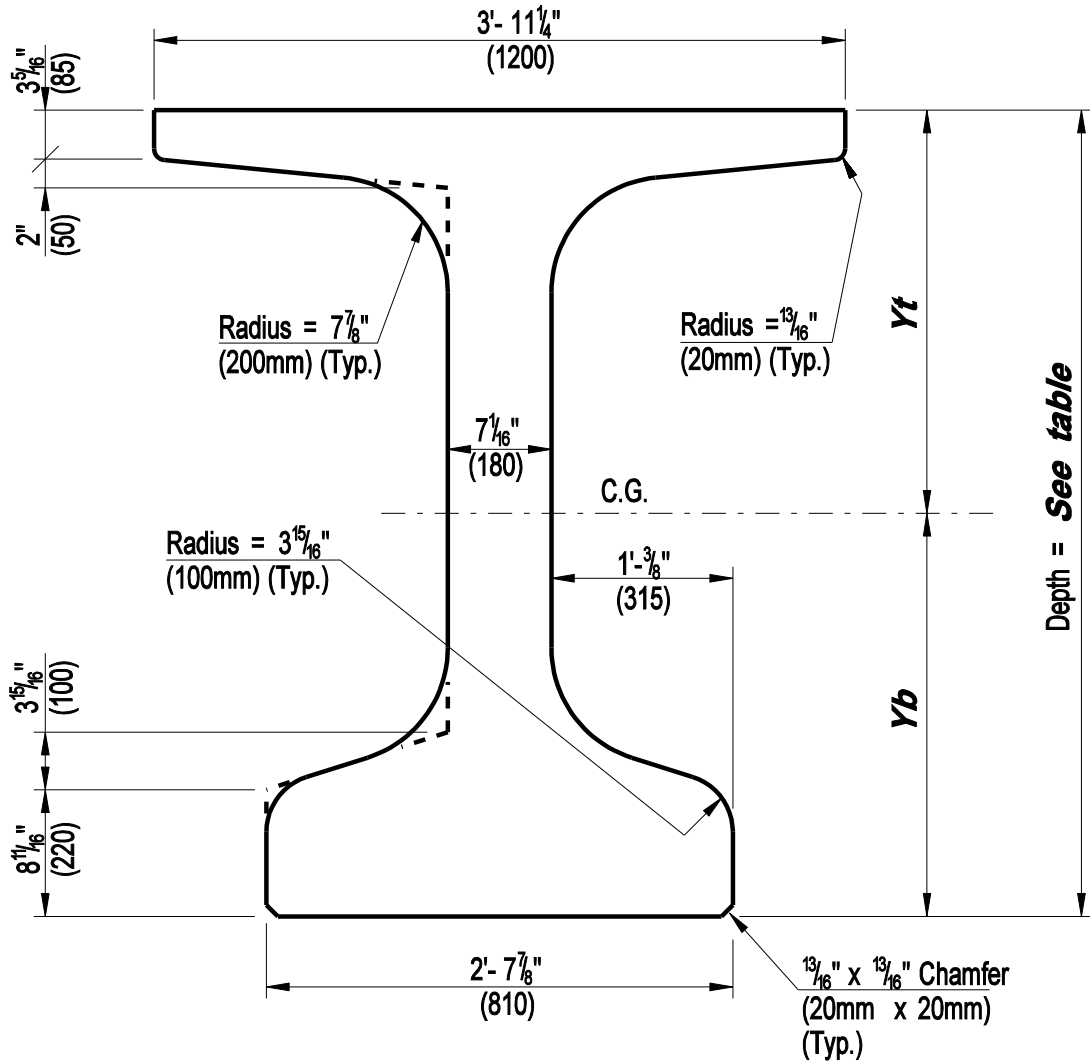

Beam Type	Depth (in)	Weight (lbs/ft)	Area (in ²)	I _x c.g. (in ⁴)	I _y c.g. (in ⁴)	Y _t (in)	Y _b (in)	S _t (in ³)	S _b (in ³)
NEBT 1000	39.37	777.47	745.55	149,196	61,744	20.35	19.02	7323	7872
NEBT 1200	47.24	835.26	801.35	238,089	61,985	24.61	22.64	9703	10,496
NEBT 1400	55.12	893.72	857.15	353,169	62,225	28.86	26.26	12,205	13,425
NEBT 1600	62.99	951.51	912.95	492,514	62,465	33.03	29.96	14,890	16,415
NEBT 1800	70.87	1009.97	968.75	666,690	62,706	37.20	33.66	17,758	19,589

DESIGN INFORMATION

- $f'_c = 6500 \text{ psi (precast)}$
 $f'_c = 4500 \text{ psi (deck)}$
 Max. Beam spacing = 6'-6"
 Allowable Tension = 0.0

2. Metric dimensions are given () for correlation to standard NEBT metric forms.

**CONNECTICUT
BRIDGE DESIGN
MANUAL**

**SECTION PROPERTIES
NEW ENGLAND BULB TEES
(TYPE NEBT 40 - 72)**

Issue Date: 10/03

Revision Date:

Plate Number:
5.4.1

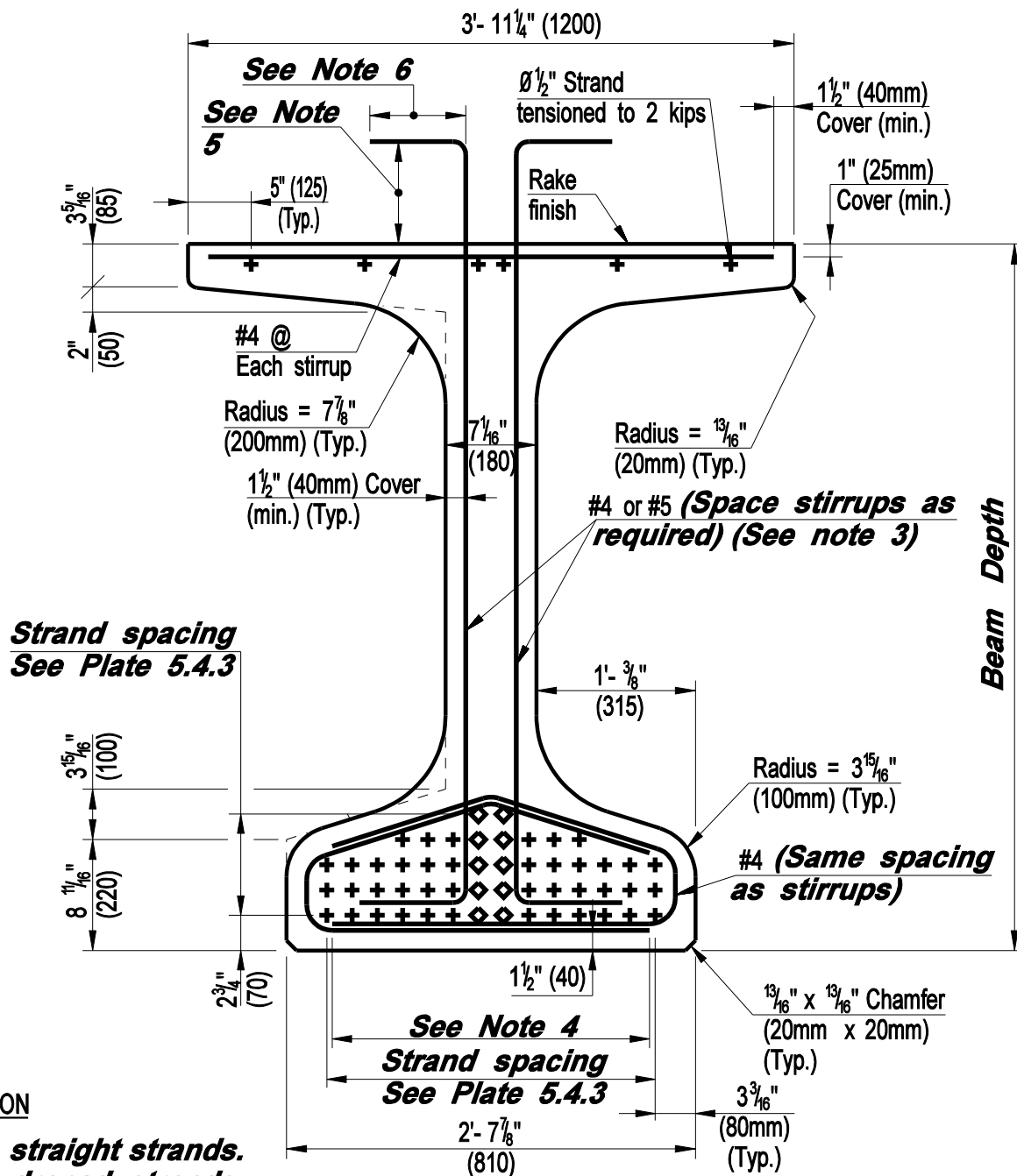

DESIGN INFORMATION

1. + Denotes straight strands.
2. ◇ Denotes draped strands.
3. Stirrups to be designed in accordance with AASHTO shear reinforcement requirements.
4. Lap splices in accordance with AASHTO requirements
5. Stirrups shall be checked for horizontal shear at the interface with the deck. Provide 6" (150mm) minimum embedment and 2" (50mm) minimum cover at top of deck.
6. Top of stirrups to constitute a standard hook in accordance with AASHTO.
7. Metric dimensions are given () for correlation to standard NEBT metric forms.

**CONNECTICUT
BRIDGE DESIGN
MANUAL**

TYPICAL MIDSPAN SECTION
NEW ENGLAND
BULB TEE BEAMS

Issue Date: 10/03

Revision Date:

Plate Number:

5.4.2

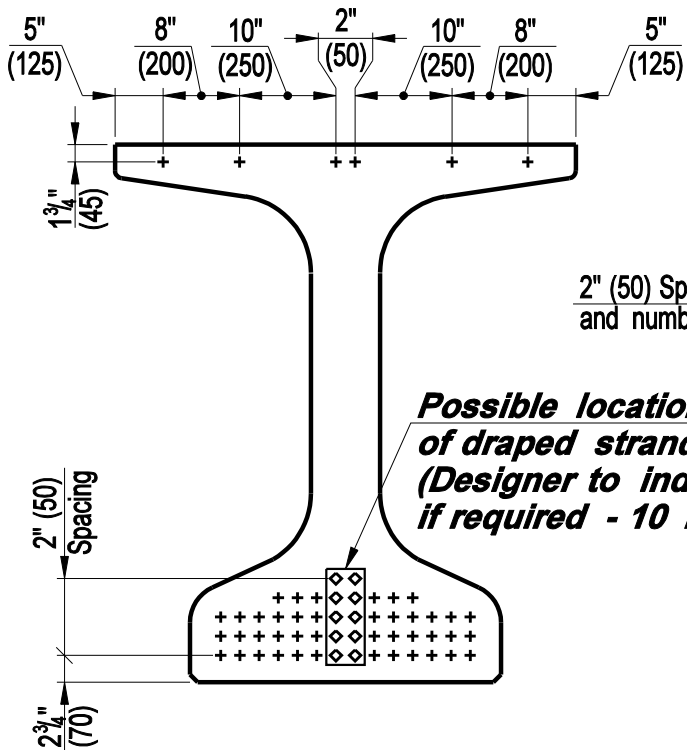

STRAND LOCATION MIDSPAN

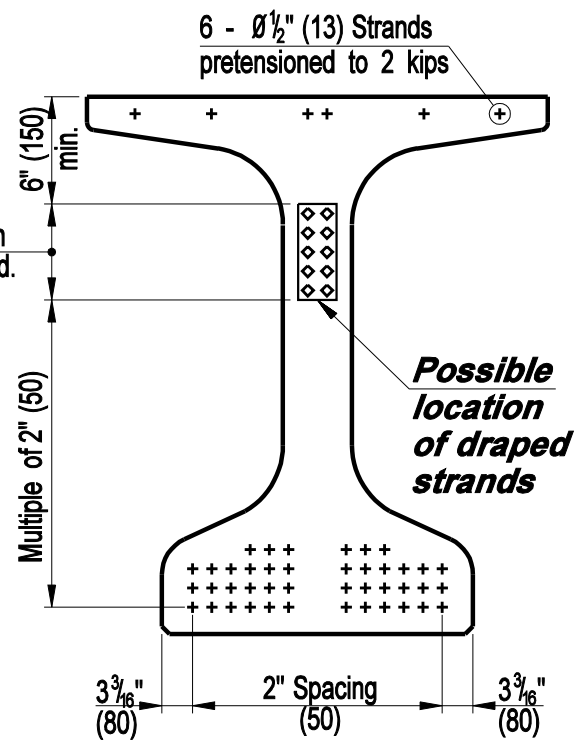

STRAND LOCATION BEAM END

DESIGN INFORMATION

1. + Denotes straight strands.
2. ◇ Denotes draped strands.
3. Strands in top flange are for fabrication purposes only and are not considered in the design.
4. Strands shall be placed within a 2" x 2" (50mm x 50mm) grid. The number and location of the strands shall be as required by design.
5. Metric dimensions are given () for correlation to standard NEBT metric forms.

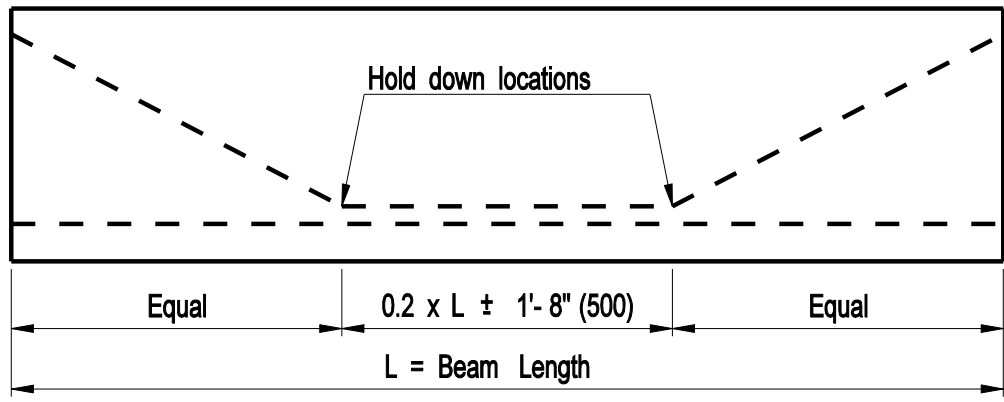

HOLD DOWN POINTS FOR DRAPED STRANDS

**CONNECTICUT
BRIDGE DESIGN
MANUAL**

**STRAND LOCATIONS AND
HOLD DOWN DETAIL NEW
ENGLAND BULB TEE BEAMS**

Issue Date: 10/03

Revision Date:

Plate Number:

5.4.3

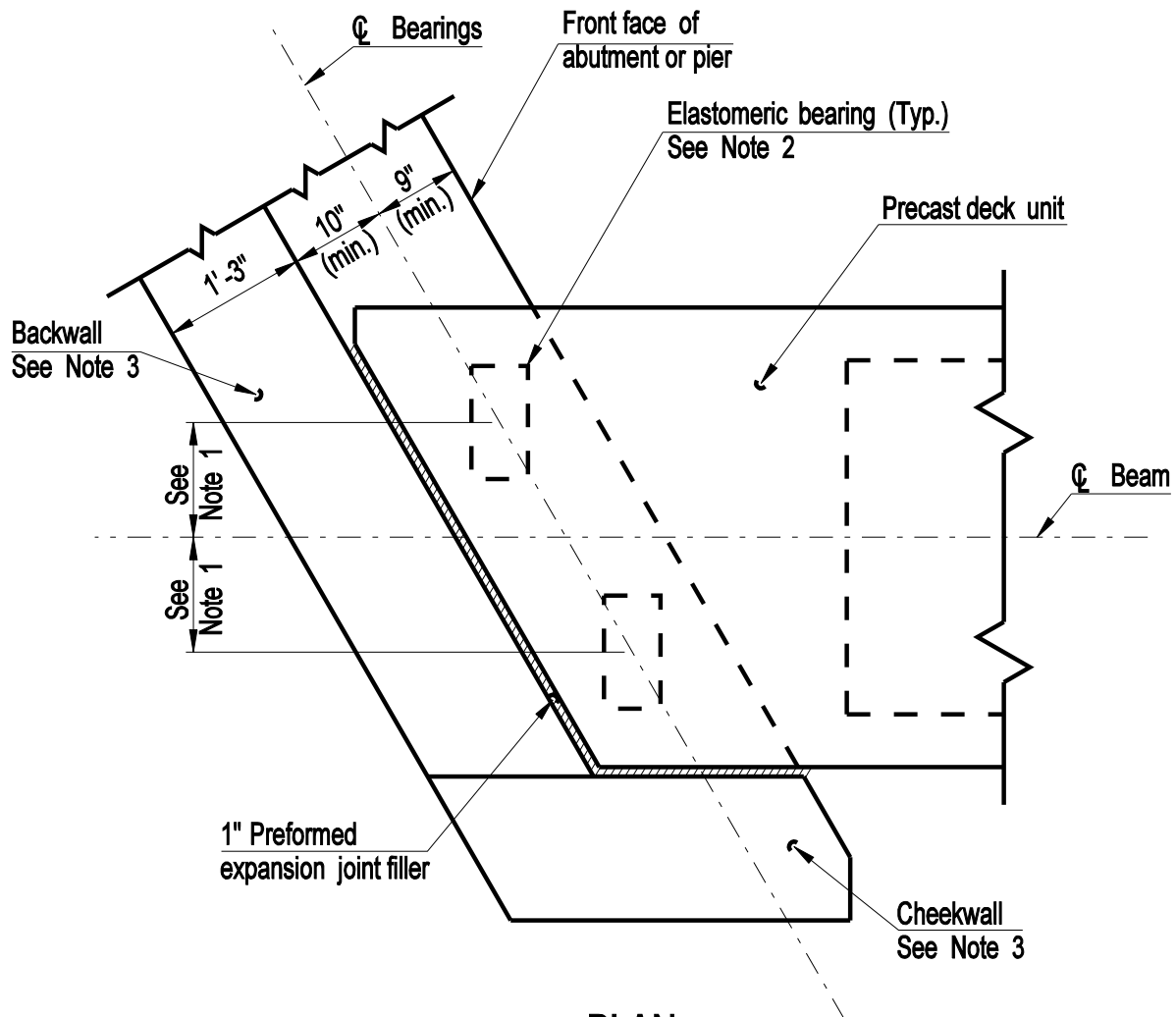

PLAN
ELASTOMERIC BEARING LAYOUT

NOTES:

1. This dimension shall be the nominal beam spacing divided by four.
2. Elastomeric bearing shall be designed according to Section 14 of the AASHTO specifications. Neoprene shims may be used to provide uniform bearing on pads offset by beam skew.
3. The backwall and cheekwall shall be designed to resist longitudinal and transverse seismic forces.

**CONNECTICUT
BRIDGE DESIGN
MANUAL**

**STANDARD PARAPET
32" HIGH
(ON VOIDED SLABS)**

Issue Date: 10/03

Revision Date:
2/11

Plate Number:
5.6.1

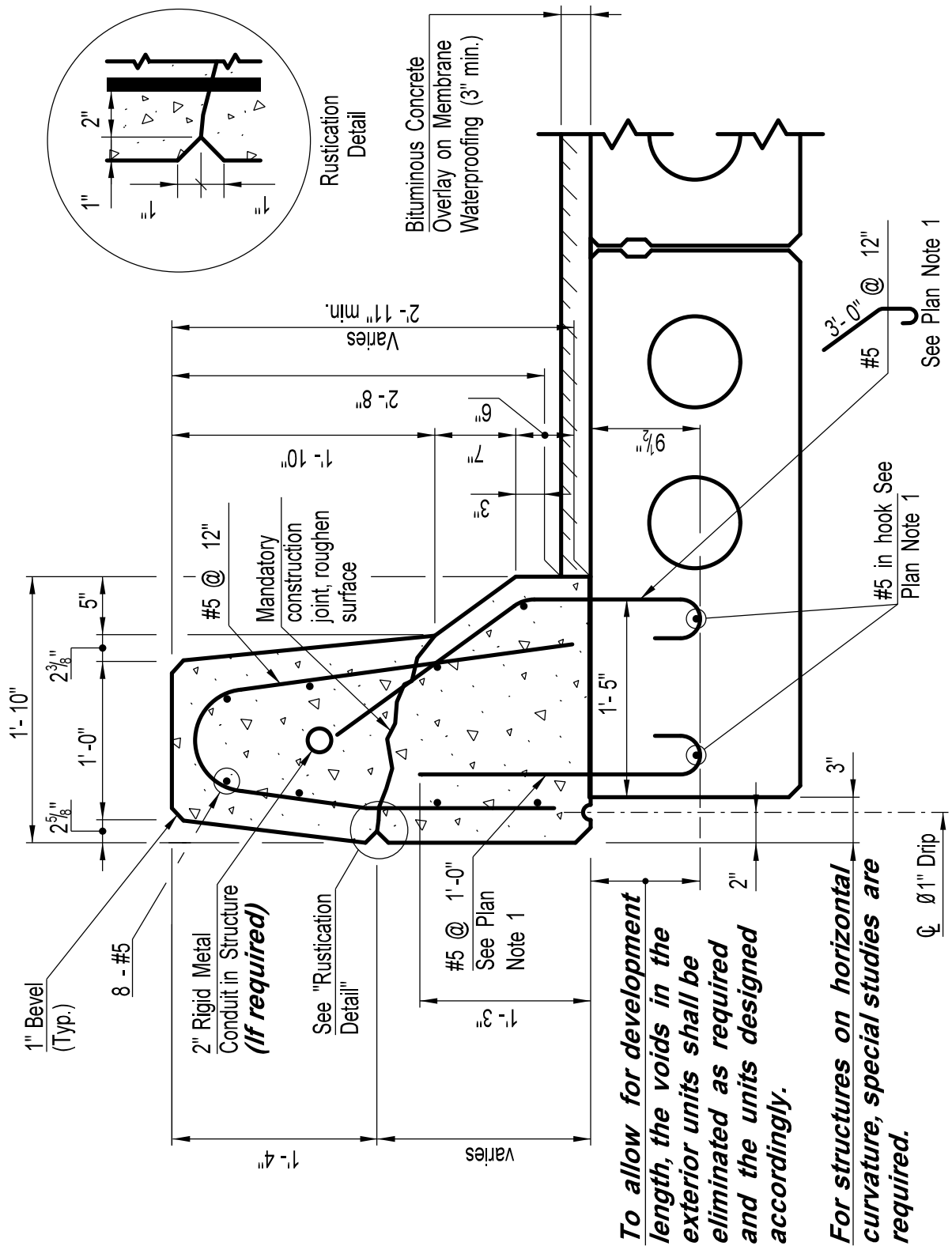

PLAN NOTES:

1. Reinforcement to be paid for under the item "Prestressed Deck Units."

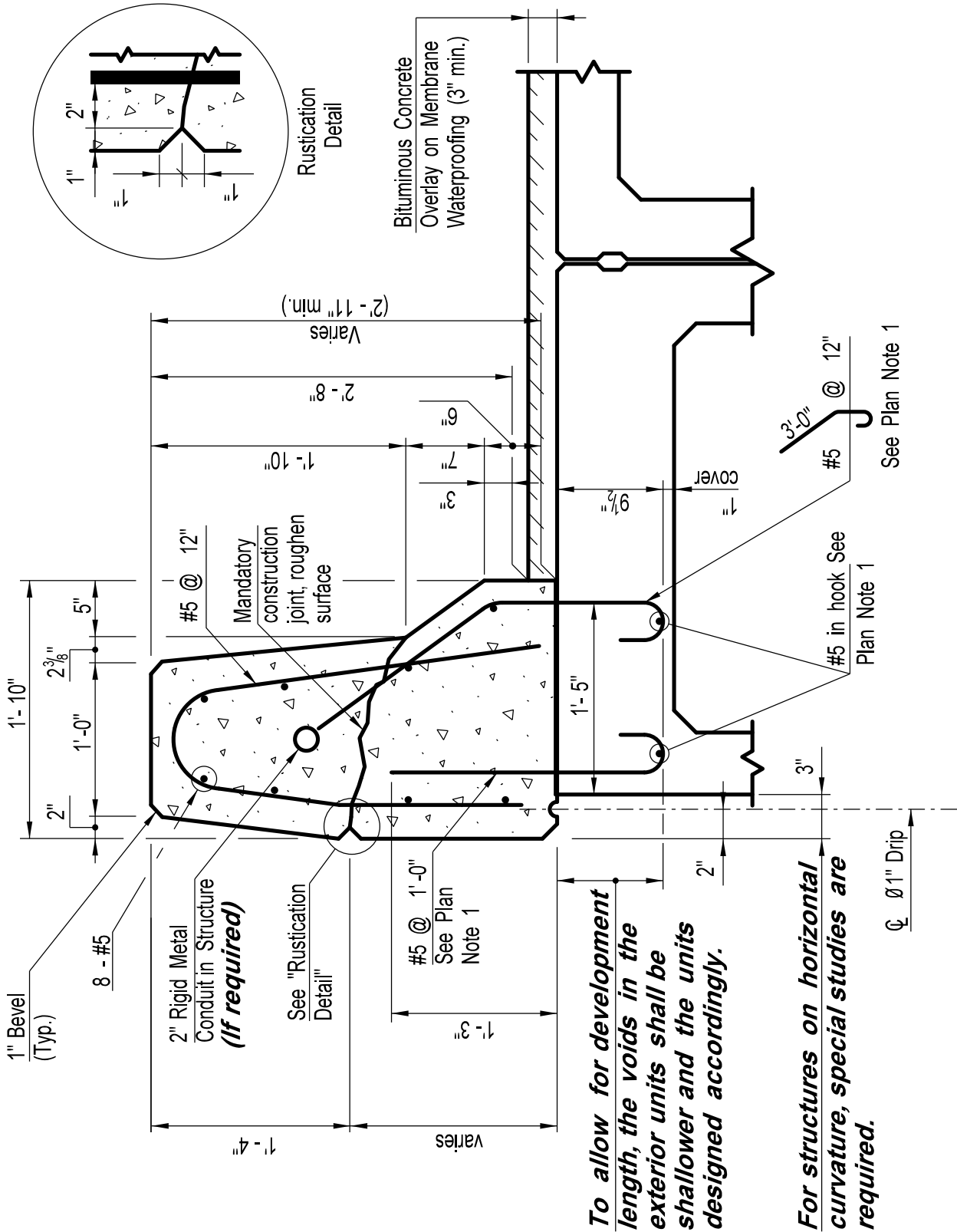

**CONNECTICUT
BRIDGE DESIGN
MANUAL**

**STANDARD PARAPET
42" HIGH
(ON VOIDED SLAB)**

Issue Date:	10/03
Revision Date:	2/11
Plate Number:	5.6.3

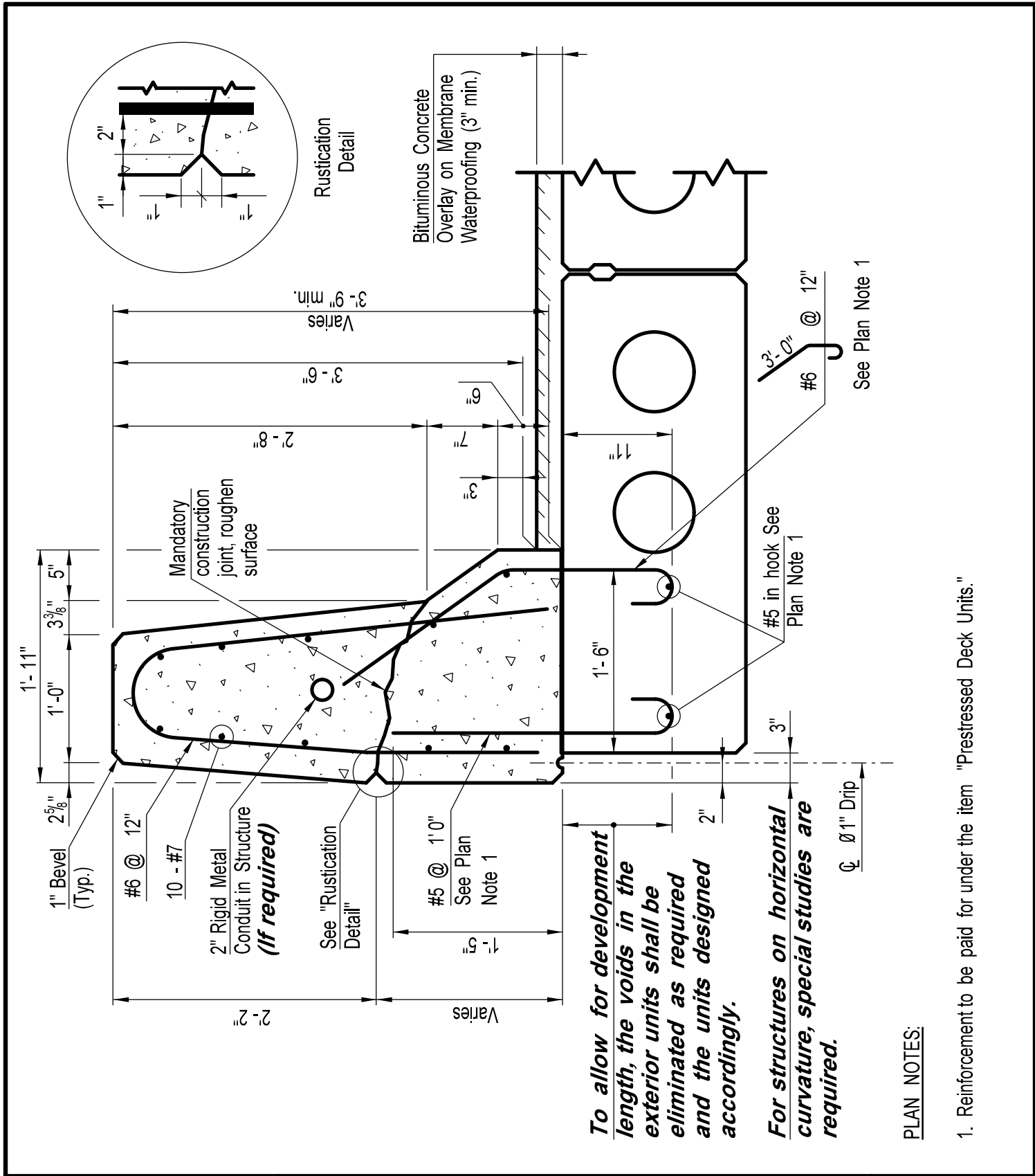

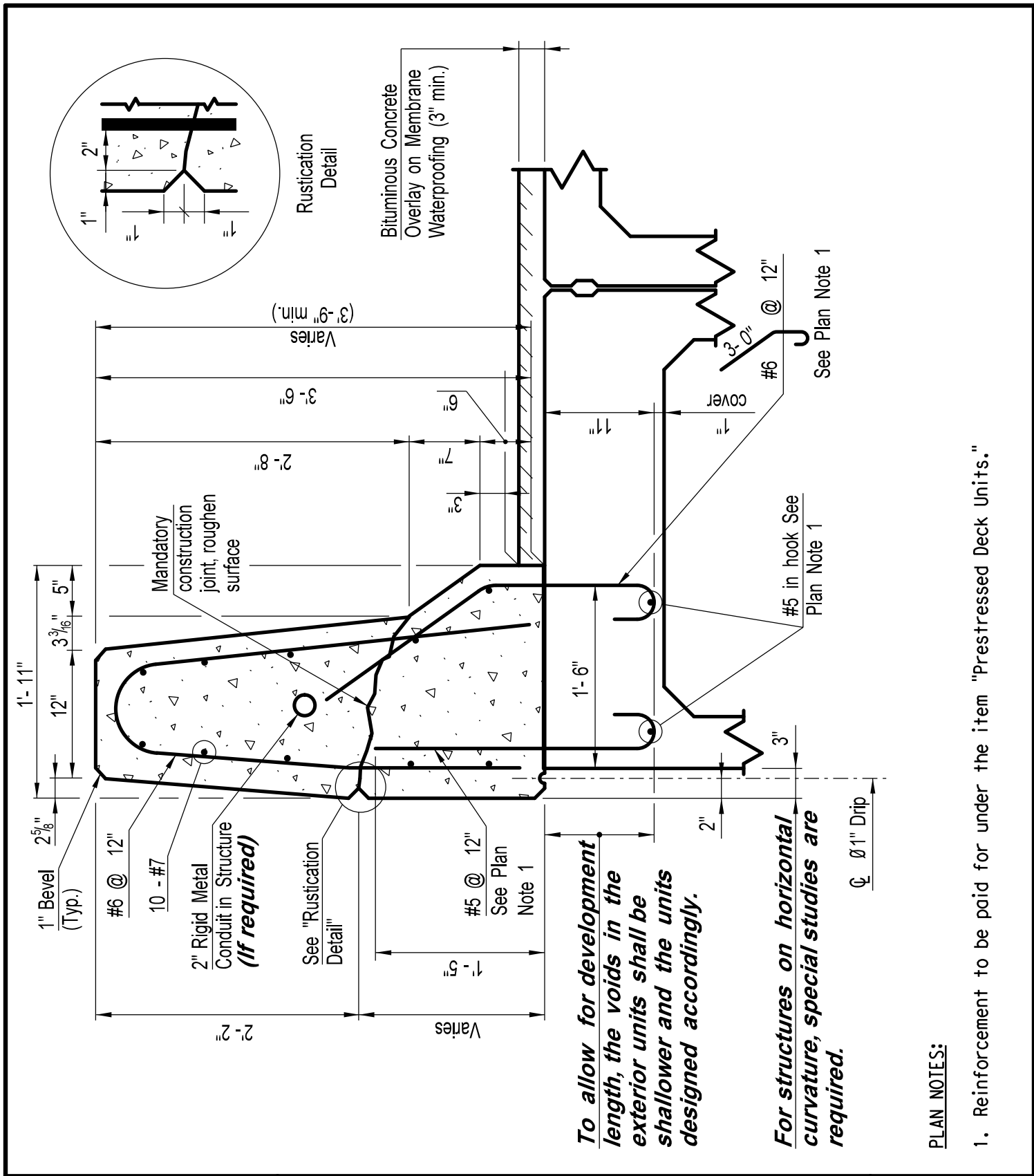

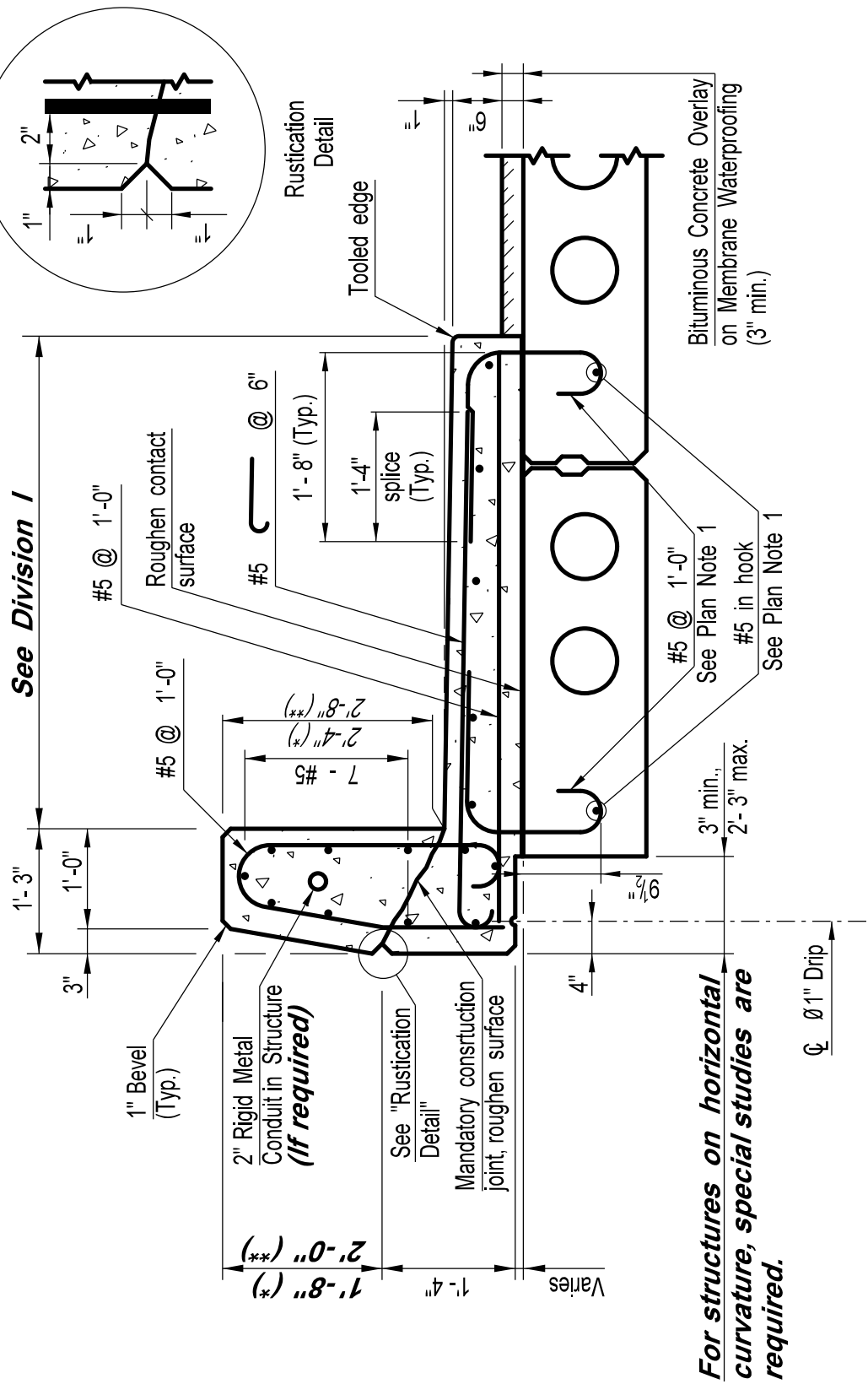

Plan Notes:

1. Reinforcement to be paid for under the item "Prestressed Deck Units."

DESIGN GUIDELINES:

- * with protective fence
- ** with pedestrian railing

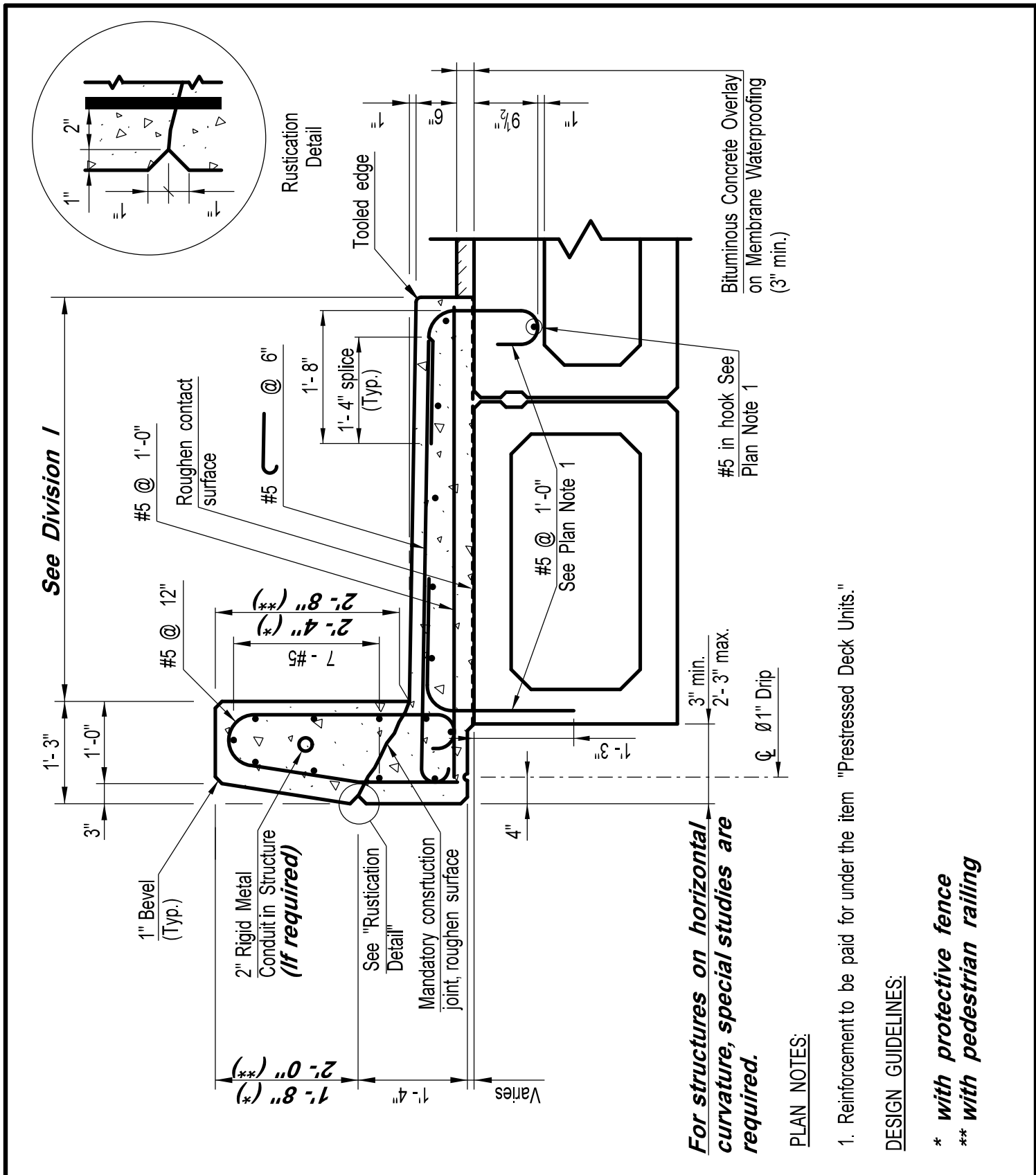

**CONNECTICUT
BRIDGE DESIGN
MANUAL**

**PARAPET
WITH SIDEWALK
(ON BUTTED BOX BEAMS)**

Issue Date:	10/03
Revision Date:	2/11
Plate Number:	5.6.6