

2.

*LETTER TO MR. DOUG
HOSKINS AT CONNECTICUT
DEEP*

DeRosa, Franca L.

From: Dean Gustafson <dgustafson@allpointstech.com>
Sent: Wednesday, February 25, 2015 2:12 PM
To: Hoskins, Douglas
Cc: Lee, Susan K NAE (Susan.K.Lee@usace.army.mil); Andy Bazinet (abazinet@cpv.com); DeRosa, Franca L.; Kyle Kekeisen (kkekeisen@cpv.com); Curt Jones (curt@civil1.com); brian@civil1.com; Small, Philip M.
Subject: PGP-201409826 (NAE-2014-2062) - CPV Towantic, LLC - Response to DEEP January 12, 2015 Comment Letter (email 1 of 2)
Attachments: CPV Towantic Test Pit & Boring Location Map.pdf; CPV Towantic Test Pit & Boring Logs.pdf; CPV Towantic USGS Groundwater Elevations.pdf; CPV Towantic Civil 1 CPV Drawing Set Rev 2-24-15.pdf; CPV Towantic Civil 1 Response to DEEP Comment Letter.pdf

Good afternoon Doug,

In response to the Department's letter of January 12, 2015 requesting additional information regarding 1) providing additional mitigation in the form of conversion of the two stormwater basins to constructed stormwater wetland basins and 2) providing additional armoring at stormwater design point DP-1, please find enclosed on behalf of the Applicant a response letter from Civil 1 addressing those comments. In addition to this letter, the following attachments referenced in the letter are enclosed herein:

Enclosures (6)

- Test Pit & Boring Location Map
- Test Pit Data Logs
- USGS Groundwater Elevation Data from Southbury
- Revised Civil 1 Site Plans, revision date February 24, 2015
- Revised Civil 1 Stormwater Management and Erosion Control Report (provided in email 2 of 2)
- Nafis & Young January 9, 2015 letter (provided in email 2 of 2)

Please feel free to contact me with any additional comments or questions.

Sincerely,
Dean

Dean E. Gustafson
Professional Soil Scientist
Senior Wetland Scientist



3 Saddlebrook Drive
Killingworth, CT 06419
860.663.1697 ext. 201 (office)
860.984.9515 (mobile)
dgustafson@allpointstech.com



February 25, 2015

Via E-Mail and First Class Mail

Mr. Doug Hoskins
Connecticut Department of Energy and Environmental Protection
Inland Water Resources Division
Bureau of Water Protection and Land Reuse
79 Elm Street
Hartford, CT 06106-5217

Re: PGP – 201409826
NAE-2014-2062
CPV Towantic Energy Project, Oxford, CT

Dear Mr. Hoskins:

On behalf of CPV Towantic, LLC, Civil 1 submits this response letter to the letter from Cheryl A. Chase, Director of the Inland Water Resource Division, dated January 12, 2015, for the above referenced project. Accordingly, please find our responses to the review comments along with the pertinent attachments:

Comment #1. Your application does not include sufficient on-site compensatory mitigation for unavoidable wetland impacts. One possible mitigation effort, if sufficient hydrology exists, would be to transform the two stormwater basins, which are assumed to be designed as dry basins, into wet basins supporting a viable stand of wetland vegetation. An analysis of this potential design feature should be performed and forwarded for our review. Be advised that created wetlands in stormwater basins are typically not to be used for compensatory mitigation, however this would be acceptable in combination with the in-lieu fee expected to be paid as part of Army Corps mitigation.

Response #1. *In order to determine if sufficient hydrology exists to support wet basins we have reviewed the geotechnical report prepared by Burns & Roe in January 2001. We have also overlaid our stormwater renovation areas on the test pit & boring location map to find the closest data points (see attached test pit & boring location mapping as well as results). While there are no borings or test pits directly in the proposed renovation areas themselves, borings were performed in proximity to both Areas A and B and the material throughout the site was found to be consistent. Therefore, the data collected from these test pits is sufficient for the purposes of evaluating the suitability of the soils and hydrology to support the two proposed basins. In general the site contains very deep glacial till.*

The executive summary of the geotechnical report states:

“This investigation indicated that typically water at the site accumulates in the upper medium dense silty sands, and is unable to penetrate the lower more dense silt soils, which appear to act as a confining unit. Test pits performed on-site generally indicated that water

T 203 266 0778
F 203 266 4759

Cornerstone
Professional Park
Suite D-101
13 Sherman Hill Road
Woodbury, CT 06798
info@CIVIL1.com
www.CIVIL1.com

will typically flow out of upper granular soils, down the sides of the excavations to the bottom. The water flow into the excavations was observed to be generally slow due to both the dense state of the subsurface soils and large amounts of fines in the materials.”

This means that the site would be suited for construction of the renovations areas as “wet basins” due to the fact that we will be intercepting the groundwater table and that our basin will be constructed in the lower, more dense soils which will be less prone to any significant exfiltration. We have attached the test pit and boring results for the locations closest to each of the basins and will discuss each further below:

Stormwater Renovation Area A:

The deepest excavations proposed are +/-16’. The closest bore holes in the area reached depths of 23’, 25’ and 29’ without encountering bedrock. Test pits done in December of 2001 indicated groundwater seepage/depths from 6’-10’ below grade. We would expect to be able to excavate without hitting bedrock and will intercept the groundwater table which will support the hydrology for a stormwater wetland in combination with the total proposed drainage area contributing to Basin A which is 9.4 acres.

Stormwater Renovation Area B:

The depth of the excavation for the basin varies from +/-26’ to a maximum of +/-35’. The closest bore holes in the area reached depths of 24’, 24’ and 29’ without encountering bedrock. All boring holes contained moist, dense silty sand at the bottom with no evidence of bedrock. Test pits done in December of 2001 indicated groundwater seepage/depths from 5’-9’ below grade. We would expect to be able to excavate without hitting bedrock and will intercept the groundwater table which will support the hydrology for a stormwater wetland in combination with the total proposed drainage area contributing to Basin B which is 8.5 acres.

It should also be noted that the test holes were done in December of 2001 during an extremely dry period. We have attached data from the closest USGS monitoring well located in Southbury that document groundwater levels during that time were in the 5-10th percentile range. The fact that groundwater was encountered on our site at depths of 5-10’ during that time further supports our evaluation that sufficient hydrology does exist to support the two wetland basins with not only the contributing drainage areas but also a significant contribution from groundwater discharge into the basins. This hydrology would support a viable stand of native wetland vegetation in both basins.

Additional confirmatory test pits in the location of the detention basins have not been completed at this time. CPV will conduct additional confirmatory test pits in the area of the detention basins and submit this information as part of the Development & Management plans to the Connecticut Siting Council (Docket No. 192B), and will also provide this information to DEEP. The information provided will at a minimum contain the location of the test pit, the surface elevation of the test pit, the soil profile encountered, the depth of the test pit, the depth to mottling (if any), the depth to ground water (if any) and the depth to ledge (if any).

T 203 266 0778
F 203 266 4759

Cornerstone
Professional Park
Suite D-101
13 Sherman Hill Road
Woodbury, CT 06798
info@CIVIL1.com
www.CIVIL1.com

CPV will also install piezometers to monitor the groundwater elevations prior to construction of the basins.

Both stormwater renovation areas have been redesigned as Extended Detention Shallow Wetlands systems in accordance with the recommendations found in the 2004 Connecticut Stormwater Quality Manual. We have attached the updated site plans as revised February 24, 2015 which show the revised basins and include detailed cross sections and planting schedules for each of the basins on Sheet C325 of the plan set. The plantings schedules, developed by Dean Gustafson, Senior Wetland Scientist with All-Points Technology Corp., P.C., identify native wetland plants indigenous to Connecticut that have been selected for the different hydrologic zones of the two Extended Detention Shallow Wetlands systems. We have also attached a revised Stormwater Management and Erosion Control Report which includes all of the supporting calculations for the Extended Detention Shallow Wetlands including the required Water Quality Volume Calculations and hydrograph routing.

Comment #2. Be advised that it is the responsibility of the designer to ensure that the stormwater outlet protection design criteria is suitable to the site and will adequately protect the outlet area from scour and erosion. The area of concern is the design point DP-1 at the location of the stormwater outfall. Given the high outlet velocity and the site grading sloping toward the neighboring property, it is recommended that the designer ensures non-erosive conditions at the end of the proposed scour hole and there is no peak flow runoff increase to the adjacent property.

Response #2. *We have provided an analysis of the existing and proposed flows for the outlet at DP-1 in the Stormwater Management and Erosion Control Report as revised February 24, 2015. We are proposing decreases in post development stormwater for all design storms (2, 10, 25, 50 and 100 year storms) which will lessen any potential for erosion. The decrease in post development flows ranges from 6.3% to 12.2%. Even though we are providing a decrease in post development flows for all of the design storms we have designed a preformed riprap scour hole in accordance with the CT DOT 2000 Drainage Manual for the existing outlet to minimize the stormwater velocities and potential for erosion. The outlet protection calculations are included in Appendix E of the Stormwater Management and Erosion Control Report.*

Comment #3 – Also, not included in the DEEP Letter of January 12, 2015, but included in your email of December 9, 2015, “Since the project involves the connection of a new stormwater drainage system to the Town’s existing one, the local authority must agree in writing to accept proposed changes/connections. Please forward any sign-offs from the town if you have them on file.

Response #3 – *Please see attached letter from Nafis & Young, the Town of Oxford’s Civil Engineers, dated January 9, 2015, confirming that the project’s connection to the Town of Oxford drainage system is acceptable.*

T 203 266 0778
F 203 266 4759

Cornerstone
Professional Park
Suite D-101

43 Sherman Hill Road
Woodbury, CT 06798
info@CIVIL1.com
www.CIVIL1.com



Please send us a response letter confirming that DEEP approves these responses. If you have any questions please feel free to contact us.

Sincerely,
CIVIL 1

A handwritten signature in black ink, appearing to read "B. Baker". The signature is fluid and cursive, with a long horizontal stroke extending to the right.

Brian J. Baker, P.E.

cc: Susan Lee, USACE – New England District
Andrew Bazinet, CPV Towantic, LLC
Franca DeRosa, Brown Rudnick LLP
Dean Gustafson, All-Points Technology Corp., P.C.

Enclosures

T 203 266 0778
F 203 266 4759

Cornerstone
Professional Park
Suite D-101
43 Sherman Hill Road
Woodbury, CT 06798
info@CIVIL1.com
www.CIVIL1.com

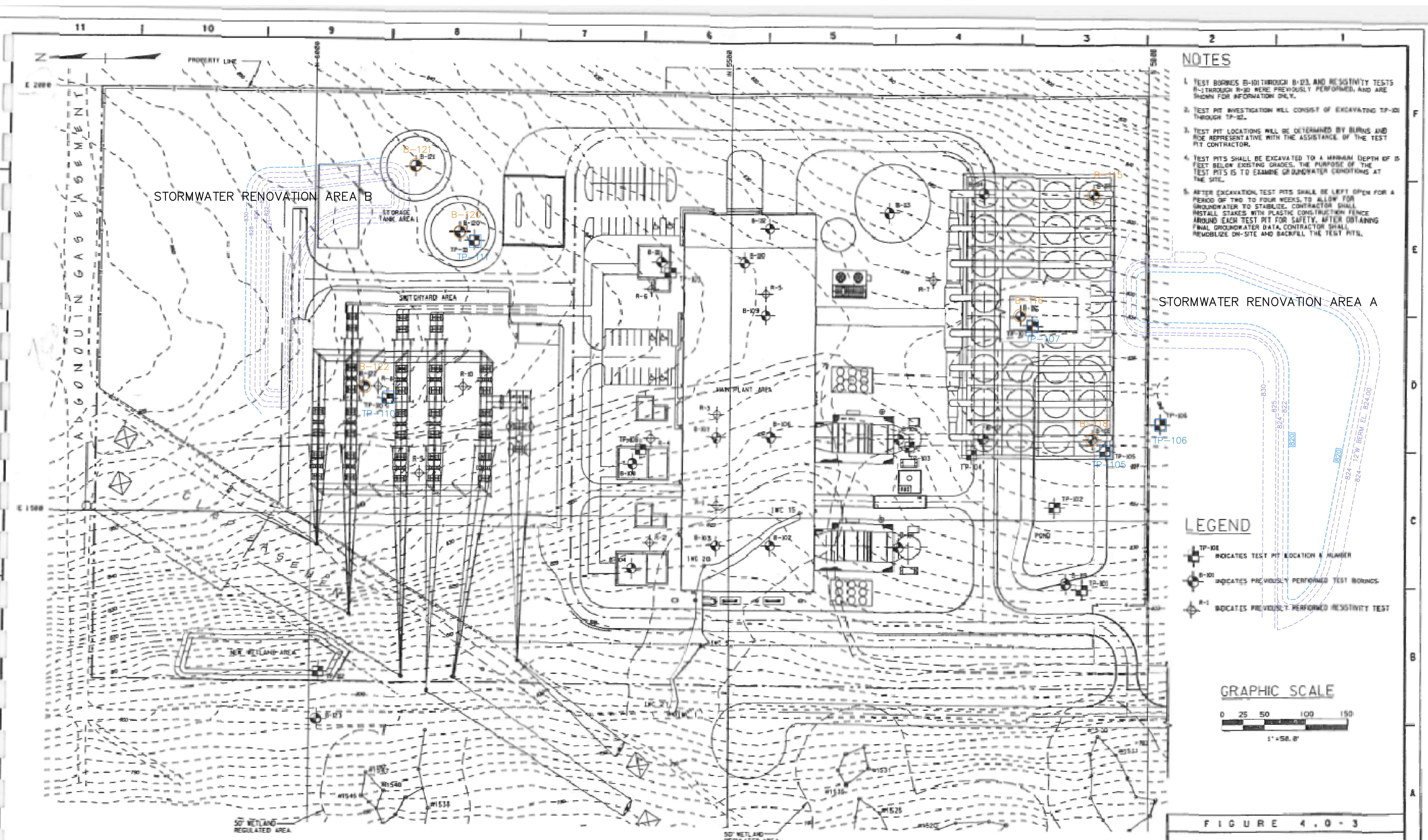

- ### NOTES
1. TEST BORINGS B-101 THROUGH B-123, AND RESISTIVITY TESTS R-1 THROUGH R-15 WERE PREVIOUSLY PERFORMED, AND ARE SHOWN FOR INFORMATION ONLY.
 2. TEST PIT INVESTIGATION WILL CONSIST OF EXCAVATING TP-101 THROUGH TP-108.
 3. TEST PIT LOCATIONS WILL BE DETERMINED BY BURNS AND ROE REPRESENTATIVE WITH THE ASSISTANCE OF THE TEST PIT CONTRACTOR.
 4. TEST PITS SHALL BE EXCAVATED TO A MINIMUM DEPTH OF 15 FEET BELOW EXISTING GRADES. THE PURPOSE OF THE TEST PITS IS TO EXAMINE GROUNDWATER CONDITIONS AT THE SITE.
 5. AFTER EXCAVATION, TEST PITS SHALL BE LEFT OPEN FOR A PERIOD OF TWO TO FOUR WEEKS TO ALLOW FOR GROUNDWATER TO STABILIZE. CONTRACTOR SHALL INSTALL STAKES WITH PLASTIC CONSTRUCTION FENCE AROUND EACH TEST PIT FOR SAFETY. AFTER OBTAINING FINAL GROUNDWATER DATA, CONTRACTOR SHALL REMEDIATE ON-SITE AND BACKFILL THE TEST PITS.

- ### LEGEND
- TP-101 INDICATES TEST PIT LOCATION & NUMBER
 - B-101 INDICATES PREVIOUSLY PERFORMED TEST BORINGS
 - R-1 INDICATES PREVIOUSLY PERFORMED RESISTIVITY TEST

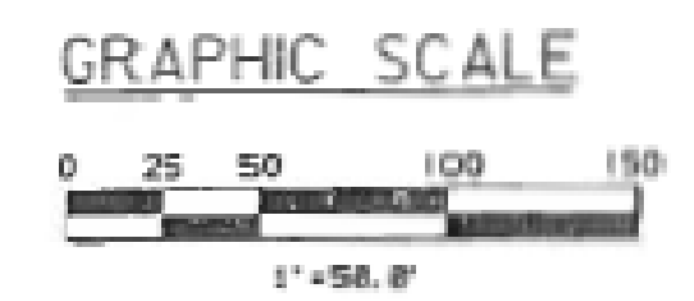

FIGURE 4.0-3

CALPINE
TORWANTIC ENERGY CENTER
OXFORD, CT

TEST PIT LOCATION PLAN

BURNS AND ROE ENTERPRISES, INC.
 Engineers and Constructors - Drilled, RI

Revision	Date	By	Check	Approved	Rev. No.	Revision	Date	By	Check	Approved	Rev. No.	Revision	Date	By	Check	Approved	Rev. No.

Drawing Control					VEVA SEDITORY		Engineering Review		
Purpose	Approved by	Date	Revised by	Date	Spec	Check	Draw	Scale	

Checked for Construction	Drawn	Scale	Drawn No.	Scale

Test Pit and Boring Results in Area of Basin A

PROJECT Towantic Energy Center PROJECT NO. 00172.00
Oxford, CT CHKD. BY WAG

BORING CO. Parratt-Wolff BORING LOCATION SEE EXPLORATION LOCATION PLAN
 FOREMAN B. Waters GROUND SURFACE ELEVATION 818.3 DATUM NGVD. 1929
 ENGINEER A. Orsi DATE START 10/11/00 DATE END 10/11/00

SAMPLER: UNLESS OTHERWISE NOTED, SAMPLER CONSISTS OF A 2" SPLIT SPOON DRIVEN USING A 140 lb. HAMMER FALLING 30 in.
 CASING: UNLESS OTHERWISE NOTED, CASING DRIVEN USING 300 lb. HAMMER FALLING 24 IN.
 CASING SIZE: OTHER: 3 3/4" H.S.A.

GROUNDWATER READINGS				
DATE	TIME	WATER AT	CASING AT	STABILIZATION TIME
10/13	9:00	Dry to 10'	-	2 Days

DEPTH (ft)	CASING (depth)	SAMPLE				TONS/FT ³ OR KG/CM ³	SAMPLE DESCRIPTION	REMARKS	STRATUM DESCRIPTION
		NO	PEN. (in.) / REC.	DEPTH (FT)	BLOWS/6"				
		S-1	18/8	0-2	2 3		5" topsoil changing to moist, loose, orange silt with sand (ML) (Subsoil)	1.	TOPSOIL
					10 20/0"			2.	SUBSOIL
		S-2	24/20	2-4	6 9		Dry, m. dense, brown silty sand with gravel (SM)		SILTY SAND WITH GRAVEL (SM)
					11 21				
5		S-3	15/12	4-8	28 37		Dry, m. dense, brown silty sand with gravel (SM)		
					50/3"				
		S-4	-	6-8	-		No sample (cobble)	3.	
		S-5	18/12	8-10	28 22		Dense, moist, orange-brown silty sand with gravel (SM)		
10					23 30/0"			4.	
		S-6	10/8	10-12	25 60/4"		Dense, moist, orange-brown silty sand with gravel (SM)		
15									
		S-7	24/24	15-17	15 23		Wet, dense, orange-brown silty sand with gravel (SM)		
					27 24				
20									
		S-8	24/24	20-22	22 32		Wet, dense, orange-brown silty sand with gravel (SM)		
					48 40				
		S-9	11/11	22-23	47 80/5"		Wet, dense, orange-brown silty sand with gravel (SM)		
							END EXPLORATION @ 23'		
25									
30									

GRANULAR SOILS		COHESIVE SOILS		REMARKS:	UNIFIED CLASSIFICATION
BLOWS/FT	DENSITY	BLOWS/FT	DENSITY		
0 - 4	V LOOSE	<2	V SOFT	1. Boring location moved 15' west to avoid boulder. 2. Grinding at 20". 3. Heavy grinding 5.5'-7'. 4. Switched from HSA to compressed air. Grnding at ~11' to 13'. 5. Hole grouted to ground surface upon completion of boring.	Gravel G
4 - 10	LOOSE	2 - 4	SOFT		Sand S
10 - 30	M DENSE	4 - 8	M STIFF		Silt M
30 - 50	DE/ISE	8 - 15	STIFF		Clay C
>50	V DENSE	15 - 30	V STIFF		Description shall reference USCS classification chart
		>30	HARD		

NOTES:

- THE STRATIFICATION LINES REPRESENT THE APPROXIMATE BOUNDARY BETWEEN SOIL TYPES, TRANSITIONS MAY BE GRADUAL. SOLID LINES INDICATE AN OBSERVED SOIL CHANGE. DASHED LINES INDICATE AN APPROXIMATED SOIL BOUNDARY.
- WATER LEVEL READINGS HAVE BEEN MADE IN THE DRILL HOLES AT TIMES AND UNDER CONDITIONS STATED ON THE BORING LOGS. FLUCTUATIONS IN THE LEVEL OF GROUNDWATER MAY OCCUR DUE TO OTHER FACTORS THAN THOSE PRESENT AT THE TIME MEASUREMENTS WERE MADE.
- STANDARD PENETRATION RESISTANCE, N-VALUE, IS THE NUMBER OF BLOWS REQUIRED TO DRIVE THE SAMPLER FROM 6-18 INCHES OF PENETRATION.
- UNCONFINED COMPRESSION STRENGTH, Qu, WAS DETERMINED FROM THE SPLIT SPOON SAMPLE UTILIZING A POCKET PENETROMETER.
- TO CONVERT FEET TO METERS MULTIPLY BY 3.048X10⁻¹

BORING NO. B115

PROJECT Towantic Energy Center PROJECT NO. 00172 00
Oxford, CT CHKD. BY Jr#E

BORING CO. Parratt-Wolff BORING LOCATION SEE EXPLORATION LOCATION PLAN
 FOREMAN B Waters GROUND SURFACE ELEVATION 834.9 DATUM NGVD 1929
 ENGINEER A Orsi DATE START 10/11/00 DATE END 10/11/00

SAMPLER: UNLESS OTHERWISE NOTED, SAMPLER CONSISTS OF A 2" SPLIT SPOON DRIVEN USING A 140 lb. HAMMER FALLING 30 in.
 CASING: UNLESS OTHERWISE NOTED, CASING DRIVEN USING 300 lb. HAMMER FALLING 24 IN.
 CASING SIZE: _____ OTHER: 3 3/4" H.S.A.

GROUNDWATER READINGS				
DATE	TIME	WATER AT	CASING AT	STABILIZATION TIME
10/11	2:30	23.68	10'	-
10/13	9:00	Dry to 15'	-	2 Days

DEPTH (M)	CASING (FEET)	SAMPLE				TONS/FT ³ OR KG/CM ³	SAMPLE DESCRIPTION	REMARKS	STRATUM DESCRIPTION
		NO	PEN (IN) / REC	DEPTH (FT)	BLOWS/FT				
		S-1	24/24	0-2	2 5 5 10		8" topsoil changing to moist, loose, orange sandy silt (ML) (Subsoil)		TOPSOIL
		S-2	24/12	2-4	27 31 22 18		Dry, dense, brown silty sand (SM) with gravel		SUBSOIL
5		S-3	24/24	4-6	10 14 15 18		Moist, m. dense, brown silty sand with gravel (SM)		SILTY SAND WITH GRAVEL (SM)
		S-4	24/24	6-8	15 22 18 16		Moist, dense, brown silty sand (SM)		
		S-5	24/24	8-10	8 10 11 12		Moist, m. dense, brown silty sand (SM)		
10		S-6	24/8	10-12	7 18 18 20		Wet, dense, brown silty sand with gravel (SM)	1.	
15		S-7	24/24	15-17	8 17 18 18		Moist, dense, brown silty sand with gravel (SM)		
20		S-8	24/24	20-22	16 21 18 18		Moist, dense, brown silty sand with gravel (SM)		
25		S-9	24/24	25-27	9 16 30 19		Moist, dense, brown silty sand (SM) with a thin layer of fine sand		
		S-10	24/24	27-29	18 24 27 44		Wet, v. dense, silty sand (SM)		
30							END EXPLORATION @ 29'		

GRANULAR SOILS		COHESIVE SOILS		REMARKS:	UNIFIED CLASSIFICATION
BLOWS/FT	DENSITY	BLOWS/FT	DENSITY		
0 - 4	V LOOSE	<2	V SOFT	1. Switch from HSA to compressed air drilling. 2. Hole grouted to ground surface upon completion of boring. 3. Boring collapsed to 15' prior to second water level reading.	Gravel G
4 - 10	LOOSE	2 - 4	SOFT		Sand S
10 - 30	M DENSE	4 - 8	M STIFF		Silt M
30 - 50	DENSE	8 - 15	STIFF		Clay C
>50	V DENSE	15 - 30	V STIFF		Description shall reference USCS classification chart
		>30	HARD		

NOTES: a) THE STRATIFICATION LINES REPRESENT THE APPROXIMATE BOUNDARY BETWEEN SOIL TYPES. TRANSITIONS MAY BE GRADUAL. SOLID LINES INDICATE AN OBSERVED SOIL CHANGE. DASHED LINES INDICATE AN APPROXIMATED SOIL BOUNDARY

b) WATER LEVEL READINGS HAVE BEEN MADE IN THE DRILL HOLES AT TIMES AND UNDER CONDITIONS STATED ON THE BORING LOGS. FLUCTUATIONS IN THE LEVEL OF GROUNDWATER MAY OCCUR DUE TO OTHER FACTORS THAN THOSE PRESENT AT THE TIME MEASUREMENTS WERE MADE.

c) STANDARD PENETRATION RESISTANCE, N-VALUE, IS THE NUMBER OF BLOWS REQUIRED TO DRIVE THE SAMPLER FROM 6-18 INCHES OF PENETRATION.

d) UNCONFINED COMPRESSION STRENGTH, C_u , WAS DETERMINED FROM THE SPLIT SPOON SAMPLE UTILIZING A POCKET PENETROMETER.

e) TO CONVERT FEET TO METERS MULTIPLY BY 3.048X10⁻¹

BORING NO. B116

PROJECT Towantic Energy Center PROJECT NO. 00172 00
Oxford, CT CHKD. BY JMB

BORING CO. Parratt-Wolff BORING LOCATION SEE EXPLORATION LOCATION PLAN
 FOREMAN B. Waters GROUND SURFACE ELEVATION 840.3 DATUM NGVD 1929
 ENGINEER A. Orsi DATE START 10/3/00 DATE END 10/3/00

SAMPLER: UNLESS OTHERWISE NOTED, SAMPLER CONSISTS OF A 2" SPLIT SPOON DRIVEN USING A 140 lb. HAMMER FALLING 30 in.

CASING: UNLESS OTHERWISE NOTED, CASING DRIVEN USING 300 lb. HAMMER FALLING 24 IN.

CASING SIZE: _____ OTHER: 3 3/4 H.S.A.

GROUNDWATER READINGS				
DATE	TIME	WATER AT	CASING AT	STABILIZATION TIME
10/3	14:45	Dry	-	-
10/4	10:15	Dry to 13'	-	1 Day
10/5	9:00	Dry	-	2 Days

DEPTH (FT)	CASING (IN)	SAMPLE				TONS/FT ³ OR KG/CM ³	SAMPLE DESCRIPTION	REMARKS	STRATUM DESCRIPTION
		NO	PEN (in y REC)	DEPTH (FT)	BLOWS/6"				
		S-1	24/14	0-2	1 2		4" topsoil changing to dry, loose, brown, well graded sand with silt and gravel (SW-SM)		TOPSOIL
		S-2	24/16	2-4	4 12		Dry, m. dense, brown silty sand (SM) with gravel		
5		S-3	24/5	4-6	9 11		Wet, m. dense, brown silt with sand (ML)		
		S-4	24/1	6-8	17 18				
					14 11				
					16 21				
		S-5	24/22	8-10	11 17		Dry, dense, brown silty sand (SM)		SILTY SAND WITH GRAVEL (SM)
10					20 19				
		S-6	24/24	10-12	12 13		Dry, m. dense, brown, silty sand with gravel (SM)		
					15 18				
15									
		S-7	24/24	15-17	11 18		Wet, dense, brown silty sand with gravel (SM)		
					18 27				
20									
		S-8	24/24	20-22	21 21		Wet, dense, brown silty sand with gravel (SM) (assumed wet, cooked dry by heat - see Note 1)		
					25 26				
		S-9	24/18	23-25	20 25		Wet, v. dense, brown silty sand with gravel (SM)		
25					32 33				
							END EXPLORATION @ 25'		
30									

GRANULAR SOILS		COHESIVE SOILS		REMARKS:	UNIFIED CLASSIFICATION
BLOWS/FT	DENSITY	BLOWS/FT	DENSITY		
0 - 4	V LOOSE	<2	V SOFT	1. Considerable Auger smoking at ~13-15' (cobbles/gravel?) 2. Hole grouted to ground surface upon completion of boring. 3. Hole collapsed to 13' prior to second water level reading.	Gravel G
4 - 10	LOOSE	2 - 4	SOFT		Sand S
10 - 30	M DENSE	4 - 8	M STIFF		Silt M
30 - 50	DENSE	8 - 15	STIFF		Clay C
>50	V DENSE	15 - 30	V STIFF		Description shall reference USCS classification chart
		>30	HARD		

NOTES:

a) THE STRATIFICATION LINES REPRESENT THE APPROXIMATE BOUNDARY BETWEEN SOIL TYPES, TRANSITIONS MAY BE GRADUAL. SOLID LINES INDICATE AN OBSERVED SOIL CHANGE. DASHED LINES INDICATE AN APPROXIMATED SOIL BOUNDARY.

b) WATER LEVEL READINGS HAVE BEEN MADE IN THE DRILL HOLES AT TIMES AND UNDER CONDITIONS STATED ON THE BORING LOGS. FLUCTUATIONS IN THE LEVEL OF GROUNDWATER MAY OCCUR DUE TO OTHER FACTORS THAN THOSE PRESENT AT THE TIME MEASUREMENTS WERE MADE.

c) STANDARD PENETRATION RESISTANCE, N-VALUE, IS THE NUMBER OF BLOWS REQUIRED TO DRIVE THE SAMPLER FROM 6-18 INCHES OF PENETRATION

d) UNCONFINED COMPRESSION STRENGTH, Qu, WAS DETERMINED FROM THE SPLIT SPOON SAMPLE UTILIZING A POCKET PENETROMETER.

e) TO CONVERT FEET TO METERS MULTIPLY BY 3.048X10⁻¹



Burns and Roe Enterprises, Inc.

Date: December 1, 2001

Test Pit No.: TP-105

Project: Towantic Energy Center
Oxford, Connecticut

Ground Elev.: +838 ft

Test Pit Log

DEPTH (ft)	SAMPLE NO.	OBSERVATION & CLASSIFICATION OF MATERIAL
0 to 9"		Topsoil over Brown fm Sand, some Clayey Silt, little fc Gravel and Cobbles (Silty Sands – SM)
9" to		
16'-3"		
		Bottom of Test Pit – 16'-3" (El +821.75 ft)

GROUNDWATER DATA

- 12/1/00 10:00 AM – No groundwater (dry) after excavallon of test pit.
- 12/1/00 3:35 PM – Groundwater beginning to accumulate at the bottom of the test pit.
- 12/5/00 – Groundwater seeping into the excavation from a depth of 8'-0".



Burns and Roe Enterprises, Inc.

Date: December 1, 2001

Test Pit No.: TP-106

Project: Towantic Energy Center
Oxford, Connecticut

Ground Elev.: +839 ft

Test Pit Log

DEPTH (ft)	SAMPLE NO.	OBSERVATION & CLASSIFICATION OF MATERIAL
0 to 9"		Topsoll over
9" to		Brown fm Sand, some Clayey Silt, little fc Gavel and Cobbles (Silty Sands – SM)
18'-6"		
		Bottom of Test Pit 18'-6" (El +820.5 ft)

GROUNDWATER DATA

12/1/00 10:45 AM – No groundwater (dry) after excavation of test pit.

12/1/00 3:30 PM – No groundwater (dry).

12/5/00 – Excavation sides moist from a depth of 6'-0" to the bottom of the test pit.



Burns and Roe Enterprises, Inc.

Date: December 1, 2001

Test Pit No.: TP-107

Project: Towantic Energy Center
Oxford, Connecticut

Ground Elev.: +835 ft

Test Pit Log

DEPTH (ft)	SAMPLE NO.	OBSERVATION & CLASSIFICATION OF MATERIAL
0 to 1'-0"		Topsoll over
1'-0" to		Tan brown fm Sand, little Clayey Silt, little fc Gavel and Cobbles (Silty Sands – SM) over
4'-0"		
4'-0" to		
		Brown fm Sand, some Silt and Clay, little fc Gravel and Cobbles (Silty Sands – SM)
17'-8"		Bottom of Test Pit – 17'-8" (El +817.3 ft)

GROUNDWATER DATA

- 12/1/00 12:00 Noon – No groundwater (dry) after excavation of the test pit.
- 12/1/00 2:30 PM – Excavation side slopes moist from a depth of 10'-0" to the bottom of the excavation.
- 12/5/00 – Groundwater at a depth of 10'-0".

Test Pit and Boring Results in Area of Basin B

PROJECT Towantic Energy Center PROJECT NO. 00172 00
Oxford, CT CHKD. BY YAC

BORING CO. Parratt-Wolf BORING LOCATION SEE EXPLORATION LOCATION PLAN
 FOREMAN B. Waters GROUND SURFACE ELEVATION 845.6 DATUM NGVD 1929
 ENGINEER A. Orsi DATE START 10/12/00 DATE END 10/12/00

SAMPLER: UNLESS OTHERWISE NOTED, SAMPLER CONSISTS OF A 2" SPLIT SPOON DRIVEN USING A 140 lb. HAMMER FALLING 30 in.
 CASING: UNLESS OTHERWISE NOTED, CASING DRIVEN USING 300 lb. HAMMER FALLING 24 in.
 CASING SIZE: OTHER: 3 3/4 H.S.A.

GROUNDWATER READINGS				
DATE	TIME	WATER AT	CASING AT	STABILIZATION TIME
10/13	8:00	Dry to 10'	-	1 Day

DEPTH (ft)	CASING (ft)	SAMPLE				TONS/FT ³ OR KG/CM ³	SAMPLE DESCRIPTION	REMARKS	STRATUM DESCRIPTION
		NO	PEN. (in.) REC.	DEPTH (FT)	BLOWS/FT				
		S-1	24/18	0-2	1 2		4" topsoil changing to moist, loose, orange silt with sand (ML) (Subsoil)		TOPSOIL
		S-2	24/18	2-4	13 16		Moist, m. dense, brown silty sand (SM) with gravel		SUBSOIL
					14 12				
5		S-3	24/12	4-6	20 27		Moist, v. dense, silty sand (SM)		
					31 32				
		S-4	24/24	6-8	14 17		Moist, m. dense, brown silty sand (SM)		
					20 23				
		S-5	24/24	8-10	4 9		Moist, m. dense, gray-brown, silty sand with gravel (SM)		
10					15 14				
		S-6	18/16	10-12	11 20		Moist, dense, gray-brown, silty sand with gravel (SM)		SILTY SAND WITH GRAVEL (SM)
					50/4"				
15									
		S-7	24/12	15-17	18 16		Moist, v. dense, gray-brown, silty sand with gravel (SM)		
					62 41				
20									
		S-8	24/12	20-22	16 39		Moist, v. dense, gray, silty sand with gravel (SM)		
					46 49				
		S-9	24/24	22-24	23 28		Moist, v. dense, gray, silty sand with gravel (SM)		
					22 27				
25							END EXPLORATION @ 24.0'		
30									

GRANULAR SOILS		COHESIVE SOILS		REMARKS:	UNIFIED CLASSIFICATION
BLOWS/FT	DENSITY	BLOWS/FT	DENSITY		
0 - 4	V LOOSE	<2	V SOFT	1. Hole grouted to ground surface upon completion of boring.	Gravel G
4 - 10	LOOSE	2 - 4	SOFT		Sand S
10 - 30	M DENSE	4 - 8	M. STIFF		Silt M
30 - 50	DENSE	8 - 15	STIFF		Clay C
>50	V DENSE	15 - 30	V. STIFF		Description shall reference
		>30	HARD		USCS classification chart

NOTES:

a) THE STRATIFICATION LINES REPRESENT THE APPROXIMATE BOUNDARY BETWEEN SOIL TYPES. TRANSITIONS MAY BE GRADUAL. SOLID LINES INDICATE AN OBSERVED SOIL CHANGE. DASHED LINES INDICATE AN APPROXIMATED SOIL BOUNDARY.

b) WATER LEVEL READINGS HAVE BEEN MADE IN THE DRILL HOLES AT TIMES AND UNDER CONDITIONS STATED ON THE BORING LOGS. FLUCTUATIONS IN THE LEVEL OF GROUNDWATER MAY OCCUR DUE TO OTHER FACTORS THAN THOSE PRESENT AT THE TIME MEASUREMENTS WERE MADE.

c) STANDARD PENETRATION RESISTANCE, N-VALUE, IS THE NUMBER OF BLOWS REQUIRED TO DRIVE THE SAMPLER FROM 6-18 INCHES OF PENETRATION

d) UNCONFINED COMPRESSION STRENGTH, Q_u, WAS DETERMINED FROM THE SPLIT SPOON SAMPLE UTILIZING A POCKET PENETROMETER.

e) TO CONVERT FEET TO METERS MULTIPLY BY 3.048x10⁻¹

PARE ENGINEERING CORPORATION
49 WALPOLE STREET, SUITE 2, NORWOOD, MASSACHUSETTS
ENGINEERS * PLANNERS *** CONSULTANTS**

BORING NO. B121
 SHEET 1 OF 1

PROJECT Towantic Energy Center PROJECT NO. 00172.00
Oxford, CT CHKD. BY JMB

BORING CO. Parratt-Wolff BORING LOCATION SEE EXPLORATION LOCATION PLAN
 FOREMAN B Waters GROUND SURFACE ELEVATION 845.7 DATUM NGVD, 1929
 ENGINEER A. Orsi DATE START 10/12/00 DATE END 10/12/00

SAMPLER: UNLESS OTHERWISE NOTED, SAMPLER CONSISTS OF A 2" SPLIT SPOON DRIVEN USING A 140 lb. HAMMER FALLING 30 in.
 CASING: UNLESS OTHERWISE NOTED, CASING DRIVEN USING 300 lb. HAMMER FALLING 24 IN.
 CASING SIZE: OTHER: 3 3/4 H.S.A.

GROUNDWATER READINGS				
DATE	TIME	WATER AT	CASING AT	STABILIZATION TIME
10/12	1:30	Dry	10	-
10/13	9:00	Dry to 13'	-	1 Day

DEPTH (ft)	CASING (in)	SAMPLE					SAMPLE DESCRIPTION	REMARKS	STRATUM DESCRIPTION
		NO.	PEN. (in.) REC.	DEPTH (FT)	BLOWS/ft	TONS/FT ³ OR KG/CM ³			
		S-1	24/12	0-2	1 2		4" topsoil changing to moist, loose, orange-brown silty sand (SM) (Subsoil)		TOPSOIL
		S-2	12/12	2-4	6 15		Moist, dense, orange-brown silty sand (SM)		SUBSOIL
					25/0*				
5		S-3	24/24	4-6	5 8		Moist, m. dense, brown silty sand with gravel (SM)		SILTY SAND WITH GRAVEL (SM)
					10 12				
		S-4	24/24	6-8	7 10		Moist, m. dense, brown silty sand with gravel (SM)		
					12 15				
		S-5	24/24	8-10	10 18		Moist, v. dense, brown silty sand with gravel (SM)		
10					39 21				
		S-6	24/12	10-12	27 28		Moist, v. dense, brown silty sand with gravel (SM)		
					27 24				
15									
		S-7	24/24	15-17	9 14		Moist, m. dense, brown silty sand with gravel (SM)		
					13 17				
20									
		S-8	24/20	20-22	15 17		Moist, dense, brown silty sand with gravel (SM)		
					23 26				
		S-9	24/24	22-24	77 28		Moist, v. dense, brown silty sand with gravel (SM)		
					34 40				
25							END EXPLORATION @ 24.0'		
30									

GRANULAR SOILS		COHESIVE SOILS		REMARKS:	UNIFIED CLASSIFICATION
BLOWS/FT	DENSITY	BLOWS/FT	DENSITY		
0 - 4	V LOOSE	<2	V.SOFT	1. Hole grouted to ground surface upon completion of boring	Gravel G
4 - 10	LOOSE	2 - 4	SOFT		Sand S
10 - 30	M DENSE	4 - 8	M STIFF		Silt M
30 - 50	DENSE	8 - 15	STIFF		Clay C
>50	V DENSE	15 - 30	V.STIFF		Description shall reference USCS classification chart
		>30	HARD		

NOTES: a) THE STRATIFICATION LINES REPRESENT THE APPROXIMATE BOUNDARY BETWEEN SOIL TYPES. TRANSITIONS MAY BE GRADUAL. SOLID LINES INDICATE AN OBSERVED SOIL CHANGE. DASHED LINES INDICATE AN APPROXIMATED SOIL BOUNDARY.
 b) WATER LEVEL READINGS HAVE BEEN MADE IN THE DRILL HOLES AT TIMES AND UNDER CONDITIONS STATED ON THE BORING LOGS. FLUCTUATIONS IN THE LEVEL OF GROUNDWATER MAY OCCUR DUE TO OTHER FACTORS THAN THOSE PRESENT AT THE TIME MEASUREMENTS WERE MADE.
 c) STANDARD PENETRATION RESISTANCE, N-VALUE, IS THE NUMBER OF BLOWS REQUIRED TO DRIVE THE SAMPLER FROM 6-18 INCHES OF PENETRATION
 d) UNCONFINED COMPRESSION STRENGTH, C_u, WAS DETERMINED FROM THE SPLIT SPOON SAMPLE UTILIZING A POCKET PENETROMETER.
 e) TO CONVERT FEET TO METERS MULTIPLY BY 3.048X10⁻¹

BORING NO. B121

PROJECT <u>Towantic Energy Center</u> <u>Oxford, CT</u>	PROJECT NO. <u>00172.00</u> CHKD. BY <u>JMB</u>
---	--

BORING CO. <u>Parrott-Wolf</u> FOREMAN <u>B. Walters</u> ENGINEER <u>A Orsi</u>	BORING LOCATION <u>SEE EXPLORATION LOCATION PLAN</u> GROUND SURFACE ELEVATION <u>849.7</u> DATUM <u>NGVD, 1929</u> DATE START <u>10/12/00</u> DATE END <u>10/12/00</u>
--	---

SAMPLER: UNLESS OTHERWISE NOTED, SAMPLER CONSISTS OF A 2" SPLIT SPOON DRIVEN USING A 140 lb. HAMMER FALLING 30 in. CASING: UNLESS OTHERWISE NOTED, CASING DRIVEN USING 300 lb. HAMMER FALLING 24 in. CASING SIZE: OTHER: <u>3 1/4 H.S.A.</u>	GROUNDWATER READINGS <table border="1" style="width:100%; border-collapse: collapse;"> <tr> <th>DATE</th> <th>TIME</th> <th>WATER AT</th> <th>CASING AT</th> <th>STABILIZATION TIME</th> </tr> <tr> <td>10/12</td> <td>10:00</td> <td>Dry</td> <td>5</td> <td>-</td> </tr> <tr> <td>10/13</td> <td>9:00</td> <td>Dry to 10'</td> <td>-</td> <td>1 Day</td> </tr> </table>	DATE	TIME	WATER AT	CASING AT	STABILIZATION TIME	10/12	10:00	Dry	5	-	10/13	9:00	Dry to 10'	-	1 Day
DATE	TIME	WATER AT	CASING AT	STABILIZATION TIME												
10/12	10:00	Dry	5	-												
10/13	9:00	Dry to 10'	-	1 Day												

DEPTH (ft)	CASING (dia)	SAMPLE				TONS/FT ³ OR KG/CM ³	SAMPLE DESCRIPTION	REMARKS	STRATUM DESCRIPTION
		NO	PEN. (n.v.) REC.	DEPTH (FT)	BLOWS/FT				
		S-1	24/3	0-2	1 5		3" topsoil		TOPSOIL
		S-2	24/0	2-4	12 26		No recovery	1.	
					24 25			2.	
5		S-3	24/24	4-6	90 19		Moist, dense, brown silty sand with gravel (SM)		
					14 18				
		S-4	24/24	6-8	15 21		Moist, dense, brown silty sand with gravel (SM)		
					20 15				
		S-5	24/18	8-10	8 10		Moist, m. dense, brown silty sand with gravel (SM)		
10					11 23				
		S-6	24/24	10-12	13 17		Moist, dense, brown silty sand with gravel (SM)		
					17 15				
									SILTY SAND WITH GRAVEL (SM)
15									
		S-7	24/24	15-17	8 18		Moist, m. dense, brown silty sand with gravel (SM)		
					28 19				
20									
		S-8	4/4	20-22	80/4"		Moist, v. dense, brown silty sand with gravel (SM)	3.	
25									
		S-9	24/24	25-27	10 12		Moist, m. dense, brown silty sand with gravel (SM)		
					15 18				
		S-10	24/24	27-29	15 18		Moist, dense, brown sandy silt (ML)		
					21 22				
30							END EXPLORATION @ 29'		

GRANULAR SOILS		COHESIVE SOILS		REMARKS:	UNIFIED CLASSIFICATION	
BLOWS/FT	DENSITY	BLOWS/FT	DENSITY			
0 - 4	V LOOSE	<2	V SOFT	1. Grinding at 4.5". 2. Switched from HSA and compressed air at 5'. 3. 80 blows on cobble at 20'4". 4. Hole grouted to ground surface upon completion of boring.	Gravel	G
4 - 10	LOOSE	2 - 4	SOFT		Sand	S
10 - 30	M DENSE	4 - 8	M STIFF		Silt	M
30 - 50	DENSE	8 - 15	STIFF		Clay	C
>50	V DENSE	15 - 30	V STIFF		Description shall reference USCS classification chart	
		>30	HARD			

NOTES:

a) THE STRATIFICATION LINES REPRESENT THE APPROXIMATE BOUNDARY BETWEEN SOIL TYPES. TRANSITIONS MAY BE GRADUAL. SOLID LINES INDICATE AN OBSERVED SOIL CHANGE. DASHED LINES INDICATE AN APPROXIMATED SOIL BOUNDARY.

b) WATER LEVEL READINGS HAVE BEEN MADE IN THE DRILL HOLES AT TIMES AND UNDER CONDITIONS STATED ON THE BORING LOGS. FLUCTUATIONS IN THE LEVEL OF GROUNDWATER MAY OCCUR DUE TO OTHER FACTORS THAN THOSE PRESENT AT THE TIME MEASUREMENTS WERE MADE.

c) STANDARD PENETRATION RESISTANCE, N-VALUE, IS THE NUMBER OF BLOWS REQUIRED TO DRIVE THE SAMPLER FROM 8-18 INCHES OF PENETRATION

d) UNCONFINED COMPRESSION STRENGTH, Qu, WAS DETERMINED FROM THE SPLIT SPOON SAMPLE UTILIZING A POCKET PENETROMETER.

e) TO CONVERT FEET TO METERS MULTIPLY BY 3.048x10⁻¹



Burns and Roe Enterprises, Inc.

Date: December 2, 2001

Test Pit No.: TP-110

Project: Towantic Energy Center
Oxford, Connecticut

Ground Elev.: +841 ft

Test Pit Log

DEPTH (ft)	SAMPLE NO.	OBSERVATION & CLASSIFICATION OF MATERIAL
0 to 9"		Topsoil over Brown fm Sand, some Silt and Clay, some fc Gravel (Silty Sands - SM)
9" to		
10'-0"		

GROUNDWATER DATA

12/5/00 - Groundwater at a depth of 9'-0".



Burns and Roe Enterprises, Inc.

Date: December 1, 2001

Test Pit No.: TP-111

Project: Towantic Energy Center
Oxford, Connecticut

Ground Elev.: +846 ft

Test Pit Log

DEPTH (ft)	SAMPLE NO.	OBSERVATION & CLASSIFICATION OF MATERIAL
0 to 6"		Topsoll over
6" to		Tan brown fm Sand, little Clay Silt, little fc Gravel
		(Silty Sands – SM) over
4'-0"		
4'-0" to		Brown fm Sand, some Silt and Clay, some fc Gravel and Cobbles
		(Silty Sands – SM)
16'-4"		
		Bottom of Test Pit 16'-4" (El +829.7 ft)

GROUNDWATER DATA

12/1/00 2:00 PM – Test pit dry; however, groundwater beginning to seep into excavation from a depth of 3 ft.

12/5/00 – Groundwater at a depth of 5'-0".



Groundwater Watch

USGS Home
Contact USGS
Search USGS

Latest News...

Site Number: 412916073121701 - CT-SB 42 SOUTHBURY, CT



DESCRIPTION
 Location: 41°29'16", Longitude: 73°13'17" NAD83
 New Haven County, Connecticut, Hydrologic Unit: 01100005
 Well depth: 83 feet
 Hole depth: 88 feet
 Land surface altitude: -453 feet above RCV039
 Well completed in "Other aquifers" (R99990TH8) national aquifer
 Well completed in "TDP" (1187TL) local aquifer

AVAILABLE DATA:

Data Type	Begin Date	End Date	Count
Current / Historical Observations	2007-10-01	2014-12-20	
Daily Data			
Depth to water level, feet below land surface	2002-03-20	2014-12-19	4377
Daily Statistics			
Depth to water level, feet below land surface	2002-03-20	2013-09-30	3971
Monthly Statistics			
Depth to water level, feet below land surface	2002-03	2013-09	
Annual Statistics			
Depth to water level, feet below land surface	2002	2013	
Field groundwater-level measurements	1993-08-19	2014-11-25	337
Water-Year Summary	2006	2013	8

Additional Data Sources	Begin Date	End Date	Count
Groundwater Watch **offsite**	1993	2014	4703

OPERATION:

Record for this site is maintained by the USGS Connecticut Water Science Center
 Email questions about this site to [Connecticut Water Science Center Water-Data Inquiries](#)

[Groundwater Watch Help Page](#)

Site Statistics

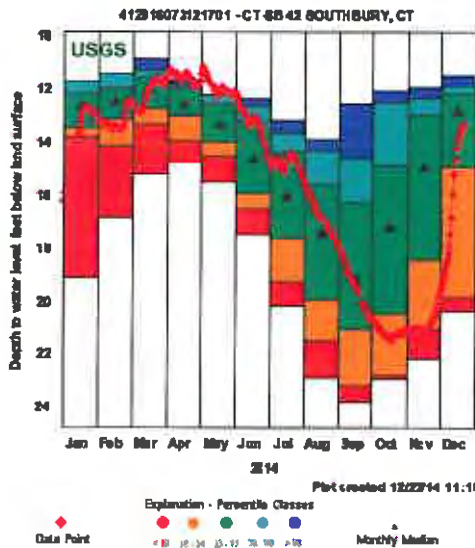

Most recent data value: **13.31** on 12/21/2014
 Period of Record Monthly Statistics for 412916073121701
 Depth to water level, feet below land surface
 All **Approved** Continuous & Periodic Data Used In Analysis
 Note: **Highlighted** values in the table indicate closest statistic to the most recent data value.

Month	Lowest	10th Median	25th %ile	50th %ile	75th %ile	90th %ile	Highest	Number of Years
Jan	19.10	13.78	13.43	12.61	12.14	11.74	11.68	21
Feb	16.83	14.11	13.10	12.48	11.98	11.41	11.39	19
Mar	15.20	13.30	12.72	12.01	11.52	11.23	10.82	20
Apr	14.79	13.90	12.97	12.58	11.96	11.82	11.65	21
May	15.47	14.51	13.97	13.37	12.54	12.22	12.20	21
Jun	17.45	16.48	15.92	14.62	13.19	12.65	12.34	21
Jul	20.15	19.25	17.61	16.06	14.35	13.65	13.15	21
Aug	22.87	21.49	19.93	17.46	15.60	14.30	13.85	22
Sep	23.79	23.19	21.06	19.17	16.24	14.61	12.53	22
Oct	22.93	22.80	20.43	17.22	14.87	12.47	12.04	21
Nov	22.17	21.09	18.43	14.96	12.96	12.34	11.90	21
Dec	20.37	19.84	14.91	12.87	12.15	11.86	11.46	21

As of 12/19/2014 20:14-2

Statistics Options
 View month/year statistics

Daily Groundwater Data

Most recent **Provisional** daily data value: **13.31** on 12/21/14

Summary for Period of Continuous Record

Depth to water level, feet below land surface

Approved Daily Mean Values Data Used In Analysis

Begin Date	End Date	Days	% Complete					
03/20/02	09/30/13	3,971	94					
Lowest Level	5th %ile	10th %ile	25th %ile	50th %ile	75th %ile	90th %ile	95th %ile	Highest Level
24.86	22.03	20.05	16.53	13.89	12.68	12.01	11.75	10.80

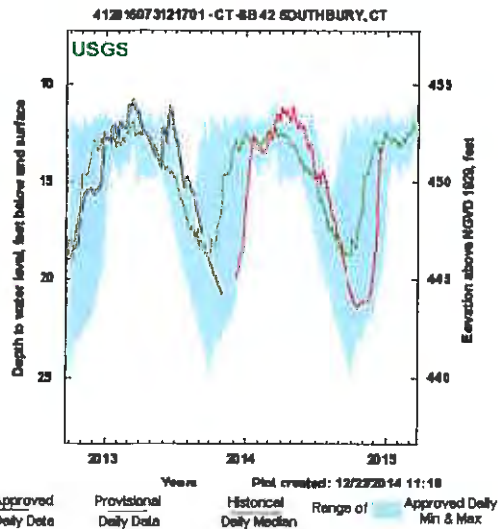

- Daily Data Options**
- View latest data on NWISWeb
 - View data in calendar format
 - Download data in text format
 - View daily medians
 - View Daily Value Moving Averages

Periodic Groundwater Data

Summary for Period of Record Periodic Water Levels

Depth to water level, feet below land surface

Approved Periodic Water Level Values

Begin Date	End Date	Number of Values	
08/19/93	11/25/14	337	
Highest WL	Date of Highest WL	Lowest WL	Date of Lowest WL
10.82	03/28/94	24.77	09/29/10

Groundwater Levels Options

- View latest data on NWISWeb
- Download Groundwater levels in text format

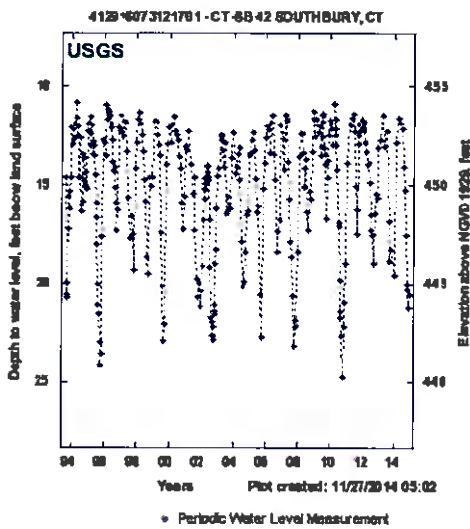

Period of Record - All Data Types

Summary for Period of Record - All Data Types

Depth to water level, feet below land surface

Begin Date	End Date	Number of Values	
08/19/93	12/21/14	5,387	
Highest WL	Date of Highest WL	Lowest WL	Date of Lowest WL
10.8	03/14/13	24.86	10/01/10

Period of Record Options

- View latest data on NWISWeb for all data types
- View annual monthly statistics for all data types
- Download Groundwater levels in text format of all data types

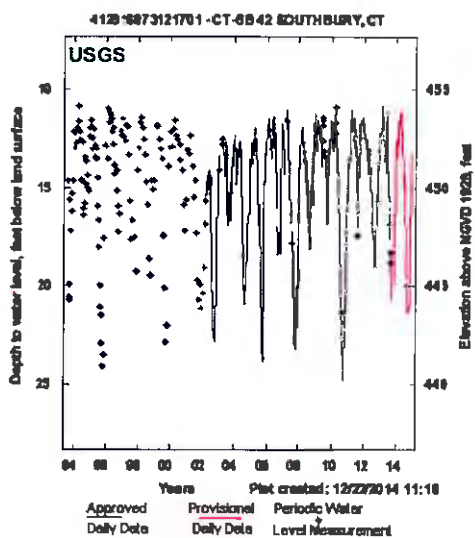

[Return to Groundwater Watch](#) |
 [Return to County Page](#) |
 [Return to State Page](#)

*References to non-Department of the Interior (DOI) products do not constitute an endorsement by the DOI.

[Accessibility](#) [FOIA](#) [Privacy](#) [Policies and Notices](#)
U.S. Department of the Interior | [U.S. Geological Survey](#)
URL: <http://groundwaterwatch.usgs.gov/AWLSites.asp>
Page Contact Information: [OGW Webmaster](#)
Last update: Thursday, November 13, 2014 at 12:35



Page displayed in 0.941 seconds.



USGS Home
 Contact USGS
 Search USGS

Groundwater Watch

Latest News...

```

# -----
# U.S. Department of the Interior
# U.S. Geological Survey
# Retrieved: 12/22/2014 1:57:05 PM
#
# ----- WARNING -----
# Some of the data you have obtained from this automated
# U.S. Geological Survey database have not received
# Director's approval and as such are provisional
# and subject to revision. The data are released
# on the condition that neither the USGS nor the
# United States Government may be held liable for
# any damages resulting from its use.
#
# This file consists of space delimited columns of data,
# which include the following fields:
#
# column          column definition
# -----
# 1. agency_cd    Agency collecting or maintaining the site
# 2. site_no      USGS site identification number
# 3. parm_code    Parameter code
# 4. lev_dt       Date
# 5. lev_va       Depth to water level, feet below land surface (Missing value indicated by '-----')
# 6. sl_lev_va    Altitude of Water Level, in Feet Above Sea Level (Missing value indicated by '-----')
# 7. lev_status_cd Water level status code, defined at: http://waterdata.usgs.gov/nwis/gwlevels/?help#
#
# Note: '*' in the status field indicates a partial date.
#
# ----- Agency Code: US GEOLOGICAL SURVEY
# ----- Station ID: 412916073121701, Station Name: CT-SB 42 SOUTHURY, CT
# ----- Start of Data
USGS 412916073121701 72019 08/19/1993 14.62 ----- -
USGS 412916073121701 72019 08/30/1993 19.92 ----- -
USGS 412916073121701 72019 09/14/1993 20.70 ----- -
USGS 412916073121701 72019 09/15/1993 20.57 ----- -
USGS 412916073121701 72019 09/27/1993 15.59 ----- -
USGS 412916073121701 72019 10/12/1993 17.22 ----- -
USGS 412916073121701 72019 10/26/1993 16.20 ----- -
USGS 412916073121701 72019 11/08/1993 15.30 ----- -
USGS 412916073121701 72019 11/26/1993 14.62 ----- -
USGS 412916073121701 72019 12/17/1993 12.13 ----- -
USGS 412916073121701 72019 12/30/1993 12.17 ----- -
USGS 412916073121701 72019 01/12/1994 12.95 ----- -
USGS 412916073121701 72019 01/27/1994 12.72 ----- -
USGS 412916073121701 72019 02/25/1994 11.94 ----- -
USGS 412916073121701 72019 03/28/1994 10.82 ----- -
USGS 412916073121701 72019 04/12/1994 11.60 ----- -
USGS 412916073121701 72019 04/25/1994 12.09 ----- -
USGS 412916073121701 72019 05/09/1994 12.57 ----- -
USGS 412916073121701 72019 05/23/1994 12.58 ----- -
USGS 412916073121701 72019 06/10/1994 14.63 ----- -
USGS 412916073121701 72019 06/27/1994 12.65 ----- -
USGS 412916073121701 72019 07/08/1994 14.65 ----- -
USGS 412916073121701 72019 07/21/1994 16.06 ----- -
USGS 412916073121701 72019 07/27/1994 16.36 ----- -
USGS 412916073121701 72019 08/10/1994 15.82 ----- -
USGS 412916073121701 72019 08/31/1994 13.47 ----- -
USGS 412916073121701 72019 09/12/1994 14.80 ----- -
USGS 412916073121701 72019 09/29/1994 13.67 ----- -
USGS 412916073121701 72019 10/12/1994 14.39 ----- -
USGS 412916073121701 72019 10/25/1994 15.03 ----- -
USGS 412916073121701 72019 11/11/1994 15.18 ----- -
USGS 412916073121701 72019 11/22/1994 15.16 ----- -
USGS 412916073121701 72019 12/16/1994 12.35 ----- -
USGS 412916073121701 72019 12/27/1994 11.95 ----- -
USGS 412916073121701 72019 01/10/1995 11.89 ----- -
USGS 412916073121701 72019 01/26/1995 11.55 ----- -
USGS 412916073121701 72019 02/10/1995 13.01 ----- -
USGS 412916073121701 72019 02/23/1995 12.45 ----- -
USGS 412916073121701 72019 03/09/1995 11.98 ----- -
USGS 412916073121701 72019 03/29/1995 12.85 ----- -
USGS 412916073121701 72019 04/10/1995 13.45 ----- -
USGS 412916073121701 72019 04/28/1995 13.05 ----- -
USGS 412916073121701 72019 05/15/1995 13.53 ----- -
    
```

USGS	412916073121701	72019	05/30/1995	14.51	-----	-
USGS	412916073121701	72019	06/19/1995	15.90	-----	-
USGS	412916073121701	72019	06/27/1995	16.65	-----	-
USGS	412916073121701	72019	07/11/1995	18.05	-----	-
USGS	412916073121701	72019	07/30/1995	19.98	-----	-
USGS	412916073121701	72019	08/07/1995	21.07	-----	-
USGS	412916073121701	72019	08/28/1995	21.53	-----	-
USGS	412916073121701	72019	09/13/1995	22.96	-----	-
USGS	412916073121701	72019	09/30/1995	24.09	-----	-
USGS	412916073121701	72019	10/17/1995	23.53	-----	-
USGS	412916073121701	72019	10/30/1995	17.61	-----	-
USGS	412916073121701	72019	11/30/1995	12.80	-----	-
USGS	412916073121701	72019	12/12/1995	12.87	-----	-
USGS	412916073121701	72019	01/11/1996	13.51	-----	-
USGS	412916073121701	72019	01/29/1996	10.97	-----	-
USGS	412916073121701	72019	02/12/1996	11.66	-----	-
USGS	412916073121701	72019	02/28/1996	11.16	-----	-
USGS	412916073121701	72019	03/15/1996	11.29	-----	-
USGS	412916073121701	72019	03/25/1996	11.46	-----	-
USGS	412916073121701	72019	04/11/1996	11.46	-----	-
USGS	412916073121701	72019	04/29/1996	12.15	-----	-
USGS	412916073121701	72019	05/20/1996	11.95	-----	-
USGS	412916073121701	72019	05/29/1996	12.79	-----	-
USGS	412916073121701	72019	06/12/1996	13.86	-----	-
USGS	412916073121701	72019	06/24/1996	14.32	-----	-
USGS	412916073121701	72019	07/30/1996	14.10	-----	-
USGS	412916073121701	72019	08/15/1996	15.14	-----	-
USGS	412916073121701	72019	08/30/1996	15.90	-----	-
USGS	412916073121701	72019	09/11/1996	17.29	-----	-
USGS	412916073121701	72019	09/24/1996	16.30	-----	-
USGS	412916073121701	72019	10/30/1996	12.10	-----	-
USGS	412916073121701	72019	11/27/1996	12.30	-----	-
USGS	412916073121701	72019	12/26/1996	11.46	-----	-
USGS	412916073121701	72019	01/28/1997	12.38	-----	-
USGS	412916073121701	72019	02/27/1997	12.57	-----	-
USGS	412916073121701	72019	03/31/1997	11.83	-----	-
USGS	412916073121701	72019	04/24/1997	11.88	-----	-
USGS	412916073121701	72019	05/30/1997	13.37	-----	-
USGS	412916073121701	72019	06/27/1997	15.68	-----	-
USGS	412916073121701	72019	07/31/1997	17.70	-----	-
USGS	412916073121701	72019	08/28/1997	16.62	-----	-
USGS	412916073121701	72019	09/29/1997	17.51	-----	-
USGS	412916073121701	72019	10/30/1997	19.30	-----	-
USGS	412916073121701	72019	11/26/1997	14.15	-----	-
USGS	412916073121701	72019	12/30/1997	12.93	-----	-
USGS	412916073121701	72019	01/30/1998	11.68	-----	-
USGS	412916073121701	72019	02/26/1998	11.39	-----	-
USGS	412916073121701	72019	03/31/1998	11.93	-----	-
USGS	412916073121701	72019	04/30/1998	12.50	-----	-
USGS	412916073121701	72019	05/27/1998	13.36	-----	-
USGS	412916073121701	72019	06/30/1998	14.73	-----	-
USGS	412916073121701	72019	07/30/1998	15.84	-----	-
USGS	412916073121701	72019	08/31/1998	18.66	-----	-
USGS	412916073121701	72019	09/29/1998	19.49	-----	-
USGS	412916073121701	72019	10/29/1998	14.64	-----	-
USGS	412916073121701	72019	11/23/1998	15.07	-----	-
USGS	412916073121701	72019	12/23/1998	14.62	-----	-
USGS	412916073121701	72019	01/31/1999	11.84	-----	-
USGS	412916073121701	72019	02/26/1999	11.79	-----	-
USGS	412916073121701	72019	03/31/1999	12.50	-----	-
USGS	412916073121701	72019	04/29/1999	13.00	-----	-
USGS	412916073121701	72019	05/27/1999	13.51	-----	-
USGS	412916073121701	72019	06/30/1999	17.45	-----	-
USGS	412916073121701	72019	07/29/1999	20.15	-----	-
USGS	412916073121701	72019	08/26/1999	22.87	-----	-
USGS	412916073121701	72019	09/20/1999	22.08	-----	-
USGS	412916073121701	72019	10/28/1999	13.96	-----	-
USGS	412916073121701	72019	11/29/1999	12.96	-----	-
USGS	412916073121701	72019	12/29/1999	12.14	-----	-
USGS	412916073121701	72019	01/31/2000	12.90	-----	-
USGS	412916073121701	72019	02/23/2000	12.00	-----	-
USGS	412916073121701	72019	03/29/2000	11.55	-----	-
USGS	412916073121701	72019	04/26/2000	12.33	-----	-
USGS	412916073121701	72019	05/31/2000	12.49	-----	-
USGS	412916073121701	72019	06/29/2000	12.78	-----	-
USGS	412916073121701	72019	07/26/2000	13.60	-----	-
USGS	412916073121701	72019	08/30/2000	14.15	-----	-
USGS	412916073121701	72019	09/27/2000	15.89	-----	-
USGS	412916073121701	72019	10/25/2000	17.22	-----	-
USGS	412916073121701	72019	11/28/2000	15.59	-----	-
USGS	412916073121701	72019	12/27/2000	13.08	-----	-
USGS	412916073121701	72019	01/30/2001	13.30	-----	-

USGS	412916073121701	72019	02/28/2001	12.30	-----	-
USGS	412916073121701	72019	04/30/2001	13.96	-----	-
USGS	412916073121701	72019	05/30/2001	15.47	-----	-
USGS	412916073121701	72019	06/29/2001	14.62	-----	-
USGS	412916073121701	72019	07/25/2001	17.34	-----	-
USGS	412916073121701	72019	08/30/2001	19.76	-----	-
USGS	412916073121701	72019	09/26/2001	20.72	-----	-
USGS	412916073121701	72019	10/29/2001	19.91	-----	-
USGS	412916073121701	72019	11/26/2001	21.14	-----	-
USGS	412916073121701	72019	12/27/2001	20.37	-----	-
USGS	412916073121701	72019	01/29/2002	19.10	-----	-
USGS	412916073121701	72019	02/26/2002	16.83	-----	-
USGS	412916073121701	72019	03/15/2002	15.70	-----	-
USGS	412916073121701	72019	03/22/2002	15.28	-----	-
USGS	412916073121701	72019	03/25/2002	15.21	-----	-
USGS	412916073121701	72019	03/29/2002	14.96	-----	-
USGS	412916073121701	72019	04/05/2002	14.66	-----	-
USGS	412916073121701	72019	04/13/2002	14.74	-----	-
USGS	412916073121701	72019	04/20/2002	14.72	-----	-
USGS	412916073121701	72019	04/24/2002	14.91	-----	-
USGS	412916073121701	72019	04/26/2002	14.96	-----	-
USGS	412916073121701	72019	05/03/2002	14.64	-----	-
USGS	412916073121701	72019	05/11/2002	14.70	-----	-
USGS	412916073121701	72019	05/18/2002	14.35	-----	-
USGS	412916073121701	72019	05/24/2002	14.10	-----	-
USGS	412916073121701	72019	05/25/2002	14.06	-----	-
USGS	412916073121701	72019	06/02/2002	14.64	-----	-
USGS	412916073121701	72019	06/09/2002	14.74	-----	-
USGS	412916073121701	72019	06/24/2002	14.62	-----	-
USGS	412916073121701	72019	07/11/2002	16.83	-----	-
USGS	412916073121701	72019	07/30/2002	19.15	-----	-
USGS	412916073121701	72019	08/28/2002	21.72	-----	-
USGS	412916073121701	72019	08/31/2002	21.94	-----	-
USGS	412916073121701	72019	09/25/2002	22.60	-----	-
USGS	412916073121701	72019	09/29/2002	22.65	-----	-
USGS	412916073121701	72019	10/13/2002	22.81	-----	-
USGS	412916073121701	72019	10/20/2002	22.19	-----	-
USGS	412916073121701	72019	10/27/2002	21.57	-----	-
USGS	412916073121701	72019	10/30/2002	21.38	-----	-
USGS	412916073121701	72019	11/03/2002	21.12	-----	-
USGS	412916073121701	72019	11/22/2002	18.98	-----	-
USGS	412916073121701	72019	11/24/2002	18.27	-----	-
USGS	412916073121701	72019	12/14/2002	16.22	-----	-
USGS	412916073121701	72019	12/23/2002	14.58	-----	-
USGS	412916073121701	72019	01/29/2003	14.15	-----	-
USGS	412916073121701	-----	02/25/2003	-----	-----	0
USGS	412916073121701	72019	03/22/2003	12.75	-----	-
USGS	412916073121701	72019	03/25/2003	12.50	-----	-
USGS	412916073121701	72019	04/06/2003	12.54	-----	-
USGS	412916073121701	72019	04/13/2003	12.57	-----	-
USGS	412916073121701	72019	04/29/2003	13.31	-----	-
USGS	412916073121701	72019	05/28/2003	14.11	-----	-
USGS	412916073121701	72019	06/24/2003	12.87	-----	-
USGS	412916073121701	72019	07/28/2003	16.50	-----	-
USGS	412916073121701	72019	08/25/2003	15.57	-----	-
USGS	412916073121701	72019	09/24/2003	16.23	-----	-
USGS	412916073121701	72019	10/27/2003	16.23	-----	-
USGS	412916073121701	72019	11/21/2003	13.66	-----	-
USGS	412916073121701	72019	12/22/2003	12.37	-----	-
USGS	412916073121701	72019	01/27/2004	14.44	-----	-
USGS	412916073121701	72019	02/26/2004	14.11	-----	-
USGS	412916073121701	72019	03/31/2004	13.49	-----	-
USGS	412916073121701	72019	04/27/2004	13.17	-----	-
USGS	412916073121701	72019	05/05/2004	14.76	-----	-
USGS	412916073121701	72019	06/30/2004	17.90	-----	-
USGS	412916073121701	72019	07/28/2004	20.13	-----	-
USGS	412916073121701	72019	08/30/2004	19.87	-----	-
USGS	412916073121701	72019	09/28/2004	18.43	-----	-
USGS	412916073121701	72019	10/29/2004	16.55	-----	-
USGS	412916073121701	72019	11/23/2004	16.35	-----	-
USGS	412916073121701	72019	12/27/2004	13.53	-----	-
USGS	412916073121701	72019	01/28/2005	13.39	-----	-
USGS	412916073121701	72019	02/25/2005	12.77	-----	-
USGS	412916073121701	72019	03/30/2005	12.39	-----	-
USGS	412916073121701	72019	04/21/2005	13.27	-----	-
USGS	412916073121701	72019	05/25/2005	14.67	-----	-
USGS	412916073121701	72019	06/23/2005	16.44	-----	-
USGS	412916073121701	72019	07/20/2005	16.10	-----	-
USGS	412916073121701	72019	08/29/2005	20.57	-----	-
USGS	412916073121701	72019	09/20/2005	22.68	-----	-
USGS	412916073121701	72019	10/28/2005	15.22	-----	-
USGS	412916073121701	72019	11/22/2005	13.92	-----	-

USGS	412916073121701	72019	12/21/2005	12.62	-----	-
USGS	412916073121701	72019	01/27/2006	12.05	-----	-
USGS	412916073121701	72019	02/23/2006	12.26	-----	-
USGS	412916073121701	72019	03/10/2006	13.43	-----	-
USGS	412916073121701	72019	04/26/2006	11.86	-----	-
USGS	412916073121701	72019	05/22/2006	11.49	-----	-
USGS	412916073121701	72019	06/22/2006	13.49	-----	-
USGS	412916073121701	72019	07/20/2006	14.75	-----	-
USGS	412916073121701	72019	08/28/2006	18.43	-----	-
USGS	412916073121701	72019	09/22/2006	17.41	-----	-
USGS	412916073121701	72019	10/24/2006	16.80	-----	-
USGS	412916073121701	72019	11/20/2006	11.99	-----	-
USGS	412916073121701	72019	12/28/2006	12.39	-----	-
USGS	412916073121701	72019	01/29/2007	12.72	-----	-
USGS	412916073121701	72019	02/27/2007	14.23	-----	-
USGS	412916073121701	72019	03/26/2007	11.52	-----	-
USGS	412916073121701	72019	04/24/2007	11.72	-----	-
USGS	412916073121701	72019	05/29/2007	13.85	-----	-
USGS	412916073121701	72019	06/26/2007	15.71	-----	-
USGS	412916073121701	72019	07/26/2007	17.86	-----	-
USGS	412916073121701	72019	08/28/2007	18.64	-----	-
USGS	412916073121701	72019	09/20/2007	20.67	-----	-
USGS	412916073121701	72019	10/29/2007	23.13	-----	-
USGS	412916073121701	72019	11/16/2007	22.18	-----	-
USGS	412916073121701	72019	11/27/2007	21.88	-----	-
USGS	412916073121701	72019	12/27/2007	18.41	-----	-
USGS	412916073121701	72019	01/28/2008	13.62	-----	-
USGS	412916073121701	72019	02/27/2008	12.43	-----	-
USGS	412916073121701	72019	03/27/2008	12.44	-----	-
USGS	412916073121701	72019	04/24/2008	13.41	-----	-
USGS	412916073121701	72019	05/28/2008	14.15	-----	-
USGS	412916073121701	72019	06/09/2008	15.10	-----	-
USGS	412916073121701	72019	06/10/2008	15.11	-----	-
USGS	412916073121701	72019	06/25/2008	13.74	-----	-
USGS	412916073121701	72019	07/30/2008	16.40	-----	-
USGS	412916073121701	72019	08/29/2008	17.34	-----	-
USGS	412916073121701	72019	09/24/2008	15.33	-----	-
USGS	412916073121701	72019	10/27/2008	15.72	-----	-
USGS	412916073121701	72019	11/25/2008	13.35	-----	-
USGS	412916073121701	72019	12/18/2008	11.69	-----	-
USGS	412916073121701	72019	12/29/2008	11.31	-----	-
USGS	412916073121701	72019	01/22/2009	12.58	-----	-
USGS	412916073121701	72019	02/24/2009	11.71	-----	-
USGS	412916073121701	72019	03/31/2009	12.41	-----	-
USGS	412916073121701	72019	04/29/2009	12.08	-----	-
USGS	412916073121701	72019	05/27/2009	13.10	-----	-
USGS	412916073121701	72019	06/04/2009	13.55	-----	-
USGS	412916073121701	72019	06/22/2009	11.41	-----	-
USGS	412916073121701	72019	06/24/2009	11.51	-----	-
USGS	412916073121701	72019	06/26/2009	11.80	-----	-
USGS	412916073121701	72019	06/30/2009	12.57	-----	-
USGS	412916073121701	72019	07/31/2009	13.15	-----	-
USGS	412916073121701	72019	08/24/2009	13.46	-----	-
USGS	412916073121701	72019	08/31/2009	14.00	-----	-
USGS	412916073121701	72019	09/30/2009	16.73	-----	-
USGS	412916073121701	72019	10/28/2009	14.62	-----	-
USGS	412916073121701	72019	10/30/2009	13.78	-----	-
USGS	412916073121701	72019	11/30/2009	12.54	-----	-
USGS	412916073121701	72019	12/10/2009	11.91	-----	-
USGS	412916073121701	72019	12/29/2009	11.74	-----	-
USGS	412916073121701	72019	01/27/2010	12.22	-----	-
USGS	412916073121701	72019	02/23/2010	13.05	-----	-
USGS	412916073121701	72019	04/01/2010	10.89	-----	-
USGS	412916073121701	72019	04/08/2010	11.68	-----	-
USGS	412916073121701	72019	04/09/2010	12.20	-----	-
USGS	412916073121701	72019	04/15/2010	12.49	-----	-
USGS	412916073121701	72019	04/28/2010	13.03	-----	-
USGS	412916073121701	72019	05/20/2010	14.25	-----	-
USGS	412916073121701	72019	06/28/2010	16.93	-----	-
USGS	412916073121701	72019	06/30/2010	17.13	-----	-
USGS	412916073121701	72019	07/28/2010	19.82	-----	-
USGS	412916073121701	72019	08/16/2010	21.73	-----	Z
USGS	412916073121701	72019	08/23/2010	21.43	-----	-
USGS	412916073121701	72019	08/30/2010	22.64	-----	-
USGS	412916073121701	72019	09/29/2010	24.77	-----	-
USGS	412916073121701	72019	10/26/2010	22.19	-----	-
USGS	412916073121701	72019	11/15/2010	20.96	-----	-
USGS	412916073121701	72019	11/29/2010	18.96	-----	-
USGS	412916073121701	72019	12/29/2010	13.91	-----	-
USGS	412916073121701	72019	02/28/2011	11.93	-----	-
USGS	412916073121701	72019	03/30/2011	12.03	-----	-
USGS	412916073121701	72019	04/27/2011	11.60	-----	-

USGS	412916073121701	72019	05/24/2011	11.45	-----	-
USGS	412916073121701	72019	06/28/2011	12.30	-----	-
USGS	412916073121701	72019	07/25/2011	15.07	-----	-
USGS	412916073121701	72019	08/04/2011	16.27	-----	-
USGS	412916073121701	72019	08/08/2011	17.49	-----	-
USGS	412916073121701	72019	08/31/2011	12.97	-----	-
USGS	412916073121701	72019	09/13/2011	11.93	-----	-
USGS	412916073121701	72019	09/26/2011	12.49	-----	-
USGS	412916073121701	72019	10/26/2011	12.34	-----	-
USGS	412916073121701	72019	11/28/2011	11.75	-----	-
USGS	412916073121701	72019	12/02/2011	11.70	-----	-
USGS	412916073121701	72019	12/20/2011	12.15	-----	-
USGS	412916073121701	72019	01/31/2012	11.81	-----	-
USGS	412916073121701	72019	02/03/2012	11.94	-----	-
USGS	412916073121701	72019	02/06/2012	12.20	-----	-
USGS	412916073121701	72019	02/08/2012	12.33	-----	-
USGS	412916073121701	72019	02/28/2012	12.88	-----	-
USGS	412916073121701	72019	03/27/2012	13.33	-----	-
USGS	412916073121701	72019	04/24/2012	14.00	-----	-
USGS	412916073121701	72019	05/29/2012	13.92	-----	-
USGS	412916073121701	72019	06/27/2012	14.87	-----	-
USGS	412916073121701	72019	07/17/2012	16.55	-----	-
USGS	412916073121701	72019	07/27/2012	17.29	-----	-
USGS	412916073121701	72019	08/29/2012	17.60	-----	-
USGS	412916073121701	72019	09/26/2012	18.99	-----	-
USGS	412916073121701	72019	10/31/2012	16.51	-----	-
USGS	412916073121701	72019	11/27/2012	15.49	-----	-
USGS	412916073121701	72019	12/05/2012	15.64	-----	-
USGS	412916073121701	72019	12/27/2012	13.14	-----	-
USGS	412916073121701	72019	01/30/2013	12.77	-----	-
USGS	412916073121701	72019	03/25/2013	11.47	-----	-
USGS	412916073121701	72019	04/30/2013	13.11	-----	-
USGS	412916073121701	72019	06/26/2013	12.34	-----	-
USGS	412916073121701	72019	08/28/2013	16.85	-----	-
USGS	412916073121701	72019	09/11/2013	18.84	-----	-
USGS	412916073121701	72019	09/13/2013	18.30	-----	-
USGS	412916073121701	72019	12/11/2013	19.54	-----	-
USGS	412916073121701	72019	01/27/2014	12.90	-----	-
USGS	412916073121701	72019	03/25/2014	11.59	-----	-
USGS	412916073121701	72019	04/28/2014	11.89	-----	-
USGS	412916073121701	72019	05/29/2014	12.20	-----	-
USGS	412916073121701	72019	06/27/2014	14.12	-----	-
USGS	412916073121701	72019	07/30/2014	15.26	-----	-
USGS	412916073121701	72019	08/27/2014	17.60	-----	-
USGS	412916073121701	72019	09/22/2014	20.00	-----	-
USGS	412916073121701	72019	09/25/2014	20.32	-----	-
USGS	412916073121701	72019	10/28/2014	21.24	-----	-
USGS	412916073121701	72019	11/25/2014	20.60	-----	-
#	-----	End of Data				

[Return To Station Page](#) |
 [Return to County Page](#) |
 [Return to State Page](#) |
 [Return To National Page](#)

*References to non-Department of the Interior (DOI) products do not constitute an endorsement by the DOI.

[Accessibility](#) [FOIA](#) [Privacy](#) [Policies and Notices](#)
 U.S. Department of the Interior | U.S. Geological Survey
 URL: <http://groundwaterwatch.usgs.gov/DownloadWL.asp>
 Page Contact Information: [OGW Webmaster](#)
 Last update: Wednesday, July 09, 2014 at 11:30



Page displayed in 0.074 seconds.

CPV TOWANTIC ENERGY CENTER
SITE DEVELOPMENT
OXFORD, CONNECTICUT
ACOE PERMIT SUBMISSION SET

DRAWING INDEX

CIVIL DRAWINGS

DRAWING NO.	REVISION	TITLE
C001	-	COVER
C300	-	EXISTING CONDITIONS
C305	-	SITE PLAN
C310	-	STORMWATER MANAGEMENT & GRADING PLAN
C315	-	EROSION CONTROL PLAN
C320	-	DETAILS
C321	-	STORM DRAINAGE DETAILS
C325	-	STORMWATER RENOVATION AREA CROSS SECTIONS & PLANTING SCHEDULES
C330	-	EROSION CONTROL NARRATIVE

MECHANICAL DRAWINGS

DRAWING NO.	REVISION	TITLE
M301	B	GENERAL ARRANGEMENT ELEVATION LOOKING EAST

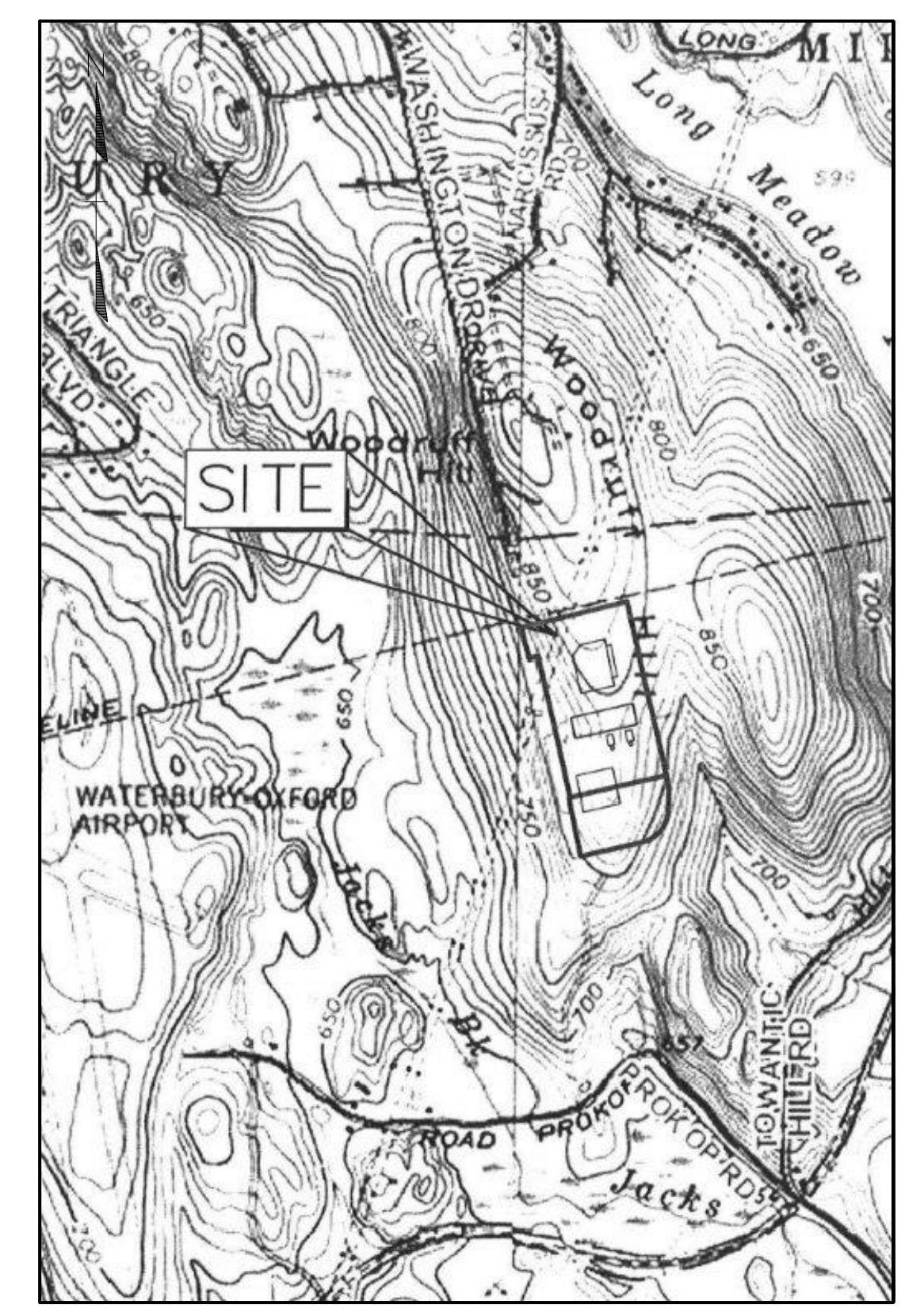

SITE MAP LOCATION
APPROXIMATE SCALE: 1"=1000'

CIVIL C1

CORNERSTONE PROFESSIONAL PARK, SUITE D-101
43 SHERMAN HILL ROAD
WOODBURY CONNECTICUT (203) 266-0778

Revision		Date	Dwn	Chkd	Approved Chief Engr	Rev No	Revision		Date	Dwn	Chkd	Approved Chief Engr	Rev No	Revision		Date	Dwn	Chkd	Approved Chief Engr	Rev No	
1	REVISED PER SITING COUNCIL REVIEW	2/13/15																			
2	REVISED PER CT DEEP REVIEW	2/24/15																			

Drawing Control				
Purpose	Approved By	Date	Released By	Date
For Information				
For Comment				
For Bid				
For Fabrication	X			
For Construction	X			

Engineering Review		CPV TOWANTIC ENERGY CENTER OXFORD, CONNECTICUT	
Disc	Engr	Date	<p style="text-align: center;">TITLE SHEET AND DRAWING LIST</p> <p style="text-align: center;"> BURNS AND ROE ENTERPRISES, INC. <small>Engineers and Constructors - Oradell, NJ Connecticut License No. PEC 39</small> </p>
Mech			
Elec			
Civil			
Arch			

Lead Engineer	Date	Approved for Construction	Work Order	Drawing No.	Sh	Rev
JH			3328	C001		F



February 25, 2015

Via E-Mail and First Class Mail

Mr. Doug Hoskins
Connecticut Department of Energy and Environmental Protection
Inland Water Resources Division
Bureau of Water Protection and Land Reuse
79 Elm Street
Hartford, CT 06106-5217

Re: PGP – 201409826
NAE-2014-2062
CPV Towantic Energy Project, Oxford, CT

Dear Mr. Hoskins:

On behalf of CPV Towantic, LLC, Civil 1 submits this response letter to the letter from Cheryl A. Chase, Director of the Inland Water Resource Division, dated January 12, 2015, for the above referenced project. Accordingly, please find our responses to the review comments along with the pertinent attachments:

Comment #1. Your application does not include sufficient on-site compensatory mitigation for unavoidable wetland impacts. One possible mitigation effort, if sufficient hydrology exists, would be to transform the two stormwater basins, which are assumed to be designed as dry basins, into wet basins supporting a viable stand of wetland vegetation. An analysis of this potential design feature should be performed and forwarded for our review. Be advised that created wetlands in stormwater basins are typically not to be used for compensatory mitigation, however this would be acceptable in combination with the in-lieu fee expected to be paid as part of Army Corps mitigation.

Response #1. *In order to determine if sufficient hydrology exists to support wet basins we have reviewed the geotechnical report prepared by Burns & Roe in January 2001. We have also overlaid our stormwater renovation areas on the test pit & boring location map to find the closest data points (see attached test pit & boring location mapping as well as results). While there are no borings or test pits directly in the proposed renovation areas themselves, borings were performed in proximity to both Areas A and B and the material throughout the site was found to be consistent. Therefore, the data collected from these test pits is sufficient for the purposes of evaluating the suitability of the soils and hydrology to support the two proposed basins. In general the site contains very deep glacial till.*

The executive summary of the geotechnical report states:

“This investigation indicated that typically water at the site accumulates in the upper medium dense silty sands, and is unable to penetrate the lower more dense silt soils, which appear to act as a confining unit. Test pits performed on-site generally indicated that water

T 203 266 0778
F 203 266 4759

Cornerstone
Professional Park
Suite D-101

13 Sherman Hill Road
Woodbury, CT 06798
info@CIVIL1.com
www.CIVIL1.com

will typically flow out of upper granular soils, down the sides of the excavations to the bottom. The water flow into the excavations was observed to be generally slow due to both the dense state of the subsurface soils and large amounts of fines in the materials.”

This means that the site would be suited for construction of the renovations areas as “wet basins” due to the fact that we will be intercepting the groundwater table and that our basin will be constructed in the lower, more dense soils which will be less prone to any significant exfiltration. We have attached the test pit and boring results for the locations closest to each of the basins and will discuss each further below:

Stormwater Renovation Area A:

The deepest excavations proposed are +/-16'. The closest bore holes in the area reached depths of 23', 25' and 29' without encountering bedrock. Test pits done in December of 2001 indicated groundwater seepage/depths from 6'-10' below grade. We would expect to be able to excavate without hitting bedrock and will intercept the groundwater table which will support the hydrology for a stormwater wetland in combination with the total proposed drainage area contributing to Basin A which is 9.4 acres.

Stormwater Renovation Area B:

The depth of the excavation for the basin varies from +/-26' to a maximum of +/-35'. The closest bore holes in the area reached depths of 24', 24' and 29' without encountering bedrock. All boring holes contained moist, dense silty sand at the bottom with no evidence of bedrock. Test pits done in December of 2001 indicated groundwater seepage/depths from 5'-9' below grade. We would expect to be able to excavate without hitting bedrock and will intercept the groundwater table which will support the hydrology for a stormwater wetland in combination with the total proposed drainage area contributing to Basin B which is 8.5 acres.

It should also be noted that the test holes were done in December of 2001 during an extremely dry period. We have attached data from the closest USGS monitoring well located in Southbury that document groundwater levels during that time were in the 5-10th percentile range. The fact that groundwater was encountered on our site at depths of 5-10' during that time further supports our evaluation that sufficient hydrology does exist to support the two wetland basins with not only the contributing drainage areas but also a significant contribution from groundwater discharge into the basins. This hydrology would support a viable stand of native wetland vegetation in both basins.

Additional confirmatory test pits in the location of the detention basins have not been completed at this time. CPV will conduct additional confirmatory test pits in the area of the detention basins and submit this information as part of the Development & Management plans to the Connecticut Siting Council (Docket No. 192B), and will also provide this information to DEEP. The information provided will at a minimum contain the location of the test pit, the surface elevation of the test pit, the soil profile encountered, the depth of the test pit, the depth to mottling (if any), the depth to ground water (if any) and the depth to ledge (if any).

T 203 266 0778
F 203 266 4759

Cornerstone
Professional Park
Suite D-101
13 Sherman Hill Road
Woodbury, CT 06798
info@CIVIL1.com
www.CIVIL1.com

CPV will also install piezometers to monitor the groundwater elevations prior to construction of the basins.

Both stormwater renovation areas have been redesigned as Extended Detention Shallow Wetlands systems in accordance with the recommendations found in the 2004 Connecticut Stormwater Quality Manual. We have attached the updated site plans as revised February 24, 2015 which show the revised basins and include detailed cross sections and planting schedules for each of the basins on Sheet C325 of the plan set. The plantings schedules, developed by Dean Gustafson, Senior Wetland Scientist with All-Points Technology Corp., P.C., identify native wetland plants indigenous to Connecticut that have been selected for the different hydrologic zones of the two Extended Detention Shallow Wetlands systems. We have also attached a revised Stormwater Management and Erosion Control Report which includes all of the supporting calculations for the Extended Detention Shallow Wetlands including the required Water Quality Volume Calculations and hydrograph routing.

Comment #2. Be advised that it is the responsibility of the designer to ensure that the stormwater outlet protection design criteria is suitable to the site and will adequately protect the outlet area from scour and erosion. The area of concern is the design point DP-1 at the location of the stormwater outfall. Given the high outlet velocity and the site grading sloping toward the neighboring property, it is recommended that the designer ensures non-erosive conditions at the end of the proposed scour hole and there is no peak flow runoff increase to the adjacent property.

Response #2. *We have provided an analysis of the existing and proposed flows for the outlet at DP-1 in the Stormwater Management and Erosion Control Report as revised February 24, 2015. We are proposing decreases in post development stormwater for all design storms (2, 10, 25, 50 and 100 year storms) which will lessen any potential for erosion. The decrease in post development flows ranges from 6.3% to 12.2%. Even though we are providing a decrease in post development flows for all of the design storms we have designed a preformed riprap scour hole in accordance with the CT DOT 2000 Drainage Manual for the existing outlet to minimize the stormwater velocities and potential for erosion. The outlet protection calculations are included in Appendix E of the Stormwater Management and Erosion Control Report.*

Comment #3 – Also, not included in the DEEP Letter of January 12, 2015, but included in your email of December 9, 2015, “Since the project involves the connection of a new stormwater drainage system to the Town’s existing one, the local authority must agree in writing to accept proposed changes/connections. Please forward any sign-offs from the town if you have them on file.

Response #3 – *Please see attached letter from Nafis & Young, the Town of Oxford’s Civil Engineers, dated January 9, 2015, confirming that the project’s connection to the Town of Oxford drainage system is acceptable.*



Please send us a response letter confirming that DEEP approves these responses. If you have any questions please feel free to contact us.

Sincerely,
CIVIL 1

A handwritten signature in blue ink, appearing to read "B. Baker".

Brian J. Baker, P.E.

cc: Susan Lee, USACE – New England District
Andrew Bazinet, CPV Towantic, LLC
Franca DeRosa, Brown Rudnick LLP
Dean Gustafson, All-Points Technology Corp., P.C.

Enclosures

T 203 266 0778
F 203 266 4759

Cornerstone
Professional Park
Suite D-101
43 Sherman Hill Road
Woodbury, CT 06798
info@CIVIL1.com
www.CIVIL1.com

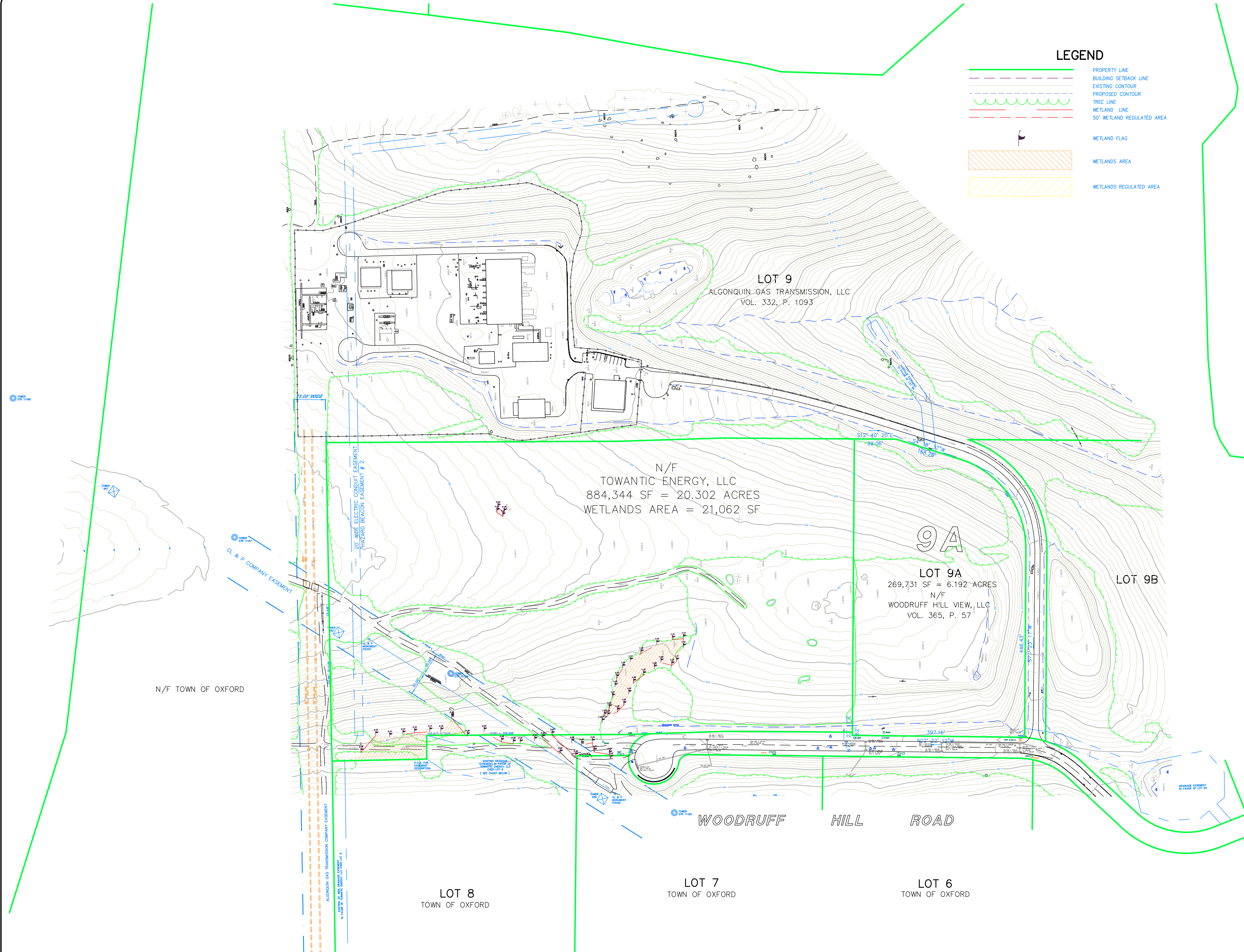

LEGEND

- PROPERTY LINE
- - - BUILDING SETBACK LINE
- - - EXISTING CONTOUR
- - - PROPOSED CONTOUR
- ~ ~ ~ TREE LINE
- - - WETLAND LINE
- - - 50' WETLAND REGULATED AREA
- WETLAND FLAG
- WETLANDS AREA
- WETLANDS REGULATED AREA

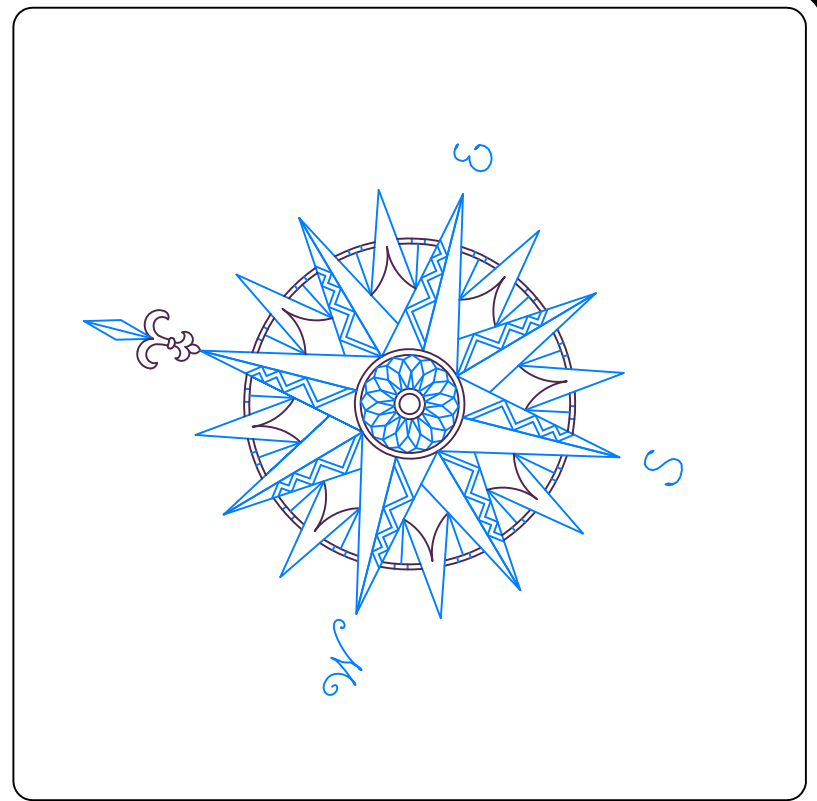

NO.	REVISION	DATE

Previous Editions Obsolete

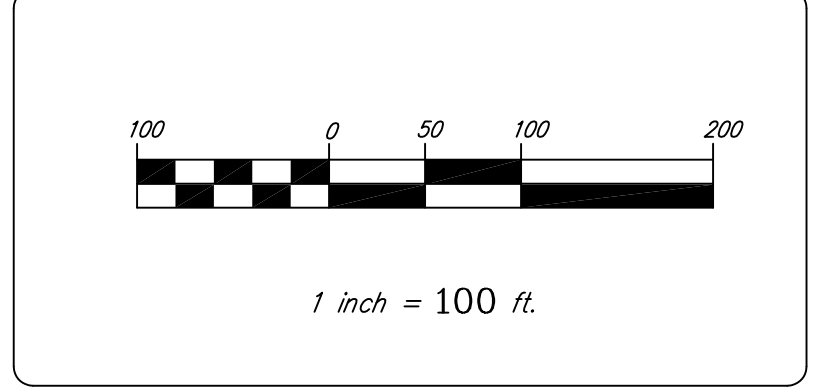

EXISTING CONDITIONS

CPV TOWANTIC ENERGY CENTER

CIVIL C1
 CORNERSTONE PROFESSIONAL PARK, SUITE D-101
 43 SHERMAN HILL ROAD
 WOODBURY CONNECTICUT (203) 266-0778

	DRAWN: SC	APPROVED: CJ
	SCALE: 1" = 100'	DATE: 26 SEP 14
	PROJ. NO.: 98132	CADD FILE NAME: 98132 Base Map
	DRAWING NO.:	
	C 300	

LOT 9
ALGONQUIN GAS TRANSMISSION, LLC
VOL. 332, P. 1093

LEGEND

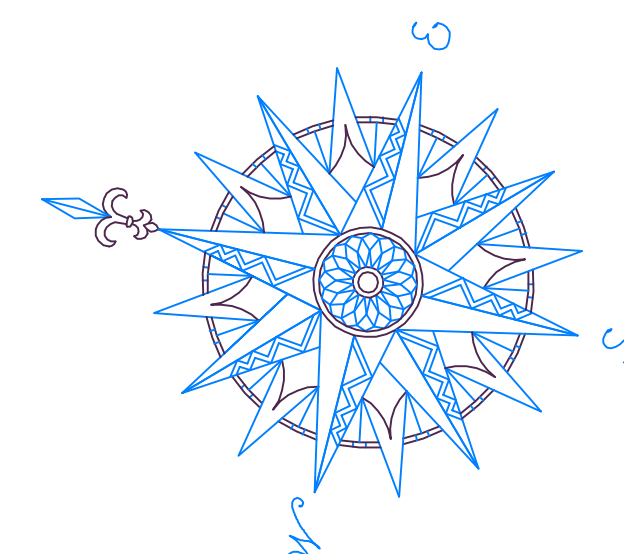
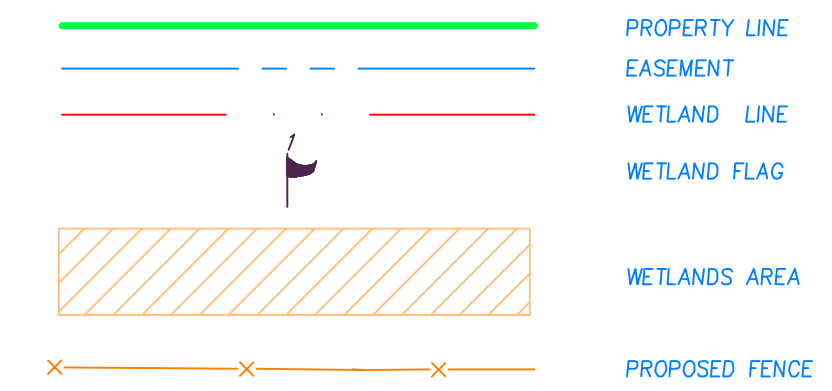

NOTES

1. TOPOGRAPHICAL MAPPING, PROPERTY SURVEY AND EXISTING FEATURES ARE BASED ON A SURVEY PREPARED BY RIOR DAN LAND SURVEYING DATED 5/10/14.
2. WETLANDS LOCATIONS AS SHOWN WERE FLAGGED BY DEAN GUSTAFSON, SOIL SCIENTIST AND LOCATED BY RIOR DAN LAND SURVEYING.
3. VERTICAL DATUM IS NAVD83.
4. HORIZONTAL DATUM IS NAD83/87 COORDINATE SYSTEM.

NO.	REVISION	DATE
1	REV. PER SITING COUNCIL REVIEW	02 FEB 15
2	REV. PER CT DEEP REVIEW	24 FEB 15

Previous Editions Obsolete

LEGEND-POWER PLANT

1. STACK
2. HRSG
3. AQUEOUS AMMONIUM STORAGE TANK/UNLOADING AREA
4. BLOWDOWN TANK
5. AUXILIARY COOLING SYSTEM FIN FAN COOLER
6. AIR COOLED CONDENSER
7. DEMINERALIZED WATER TRAILERS
8. DEMINERALIZED WATER STORAGE TANKS/PUMP HOUSE (TWO (2) TANKS EACH 875,000 GAL.)
9. FIRE/SERVICE WATER STORAGE TANK & PUMP HOUSE
10. COMBUSTION TURBINE GENERATOR
11. CTC STEP-UP TRANSFORMER
12. ISOLATION TRANSFORMER/ EXCITATION TRANSFORMER
13. CONTROL HOUSE
14. SWITCHYARD
15. GAS METERING STATION
16. ELECTRICAL/BATTERY/ DIESEL GEN. ROOMS GND FLR OFFICE/CONTROL ROOMS SECOND FLR
17. STEAM TURBINE GENERATOR WITH ENCLOSURE
18. GAS HEATER/FILTER AND METERING
19. STORM WATER DETENTION POND
20. CONDENSATE STORAGE TANK
21. FIRE PROTECTION FOAM SYSTEM ENCLOSURE
22. ACC MECHANICAL/ELECTRICAL BUILDING
23. FUEL OIL STORAGE TANK WITH SECONDARY STEEL CONTAINMENT (1,500,000 GAL.)
24. FUEL OIL UNLOADING AREA
25. FUEL OIL FORWARDING PUMP/HEATER/FILTER SKID
26. OEMS ENCLOSURE
27. HRSG CHEM FEED
28. BOILER FEED WATER PUMPS
29. AUXILIARY BOILER ROOM (GROUND FLOOR)
30. EMERGENCY DIESEL GENERATOR ROOM
31. LOAD COMMUTATING INVERTER (LCI) COMPARTMENT
32. DC LINK REACTOR
33. GENERATOR EXCITATION COMPARTMENT
34. CTC STEP-UP TRANSFORMER
35. EQUIPMENT REMOVAL AREA

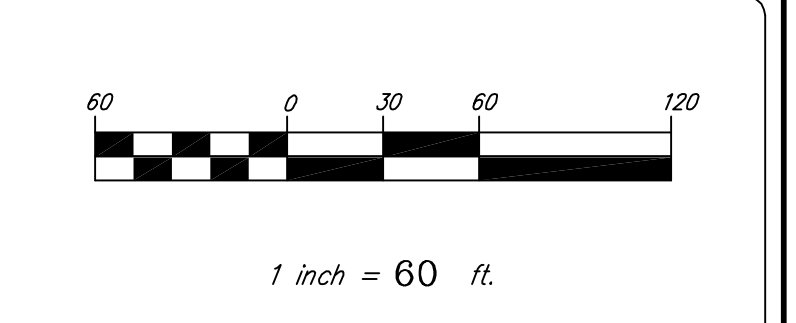

SITE PLAN

CPV TOWANTIC ENERGY CENTER

CIVIL 1
CORNERSTONE PROFESSIONAL PARK, SUITE D-101
43 SHERMAN HILL ROAD
WOODBURY CONNECTICUT (203) 266-0778

DRAWN: BB APPROVED: CJ
SCALE: 1" = 60'
DATE: 26 SEP 14
PROJ. NO.: 98132
CADD FILE NAME: 98132
DRAWING NO.: **C 305**

N/F
TOWANTIC ENERGY, LLC
884,344 SF = 20.302 ACRES
WETLANDS AREA = 21,062 SF

PLANT COORDINATE SYSTEM
E 2000.0
N 5000.0
CT STATE PLANE SYSTEM
E 498,293.1464
N 236,931.5459

PLANT GRADE=±830.0

LOT 9B

LOT 9A
269,731 SF = 6.192 ACRES
N/F
WOODRUFF, HILL VIEW, LLC
VOL. 565, P. 57

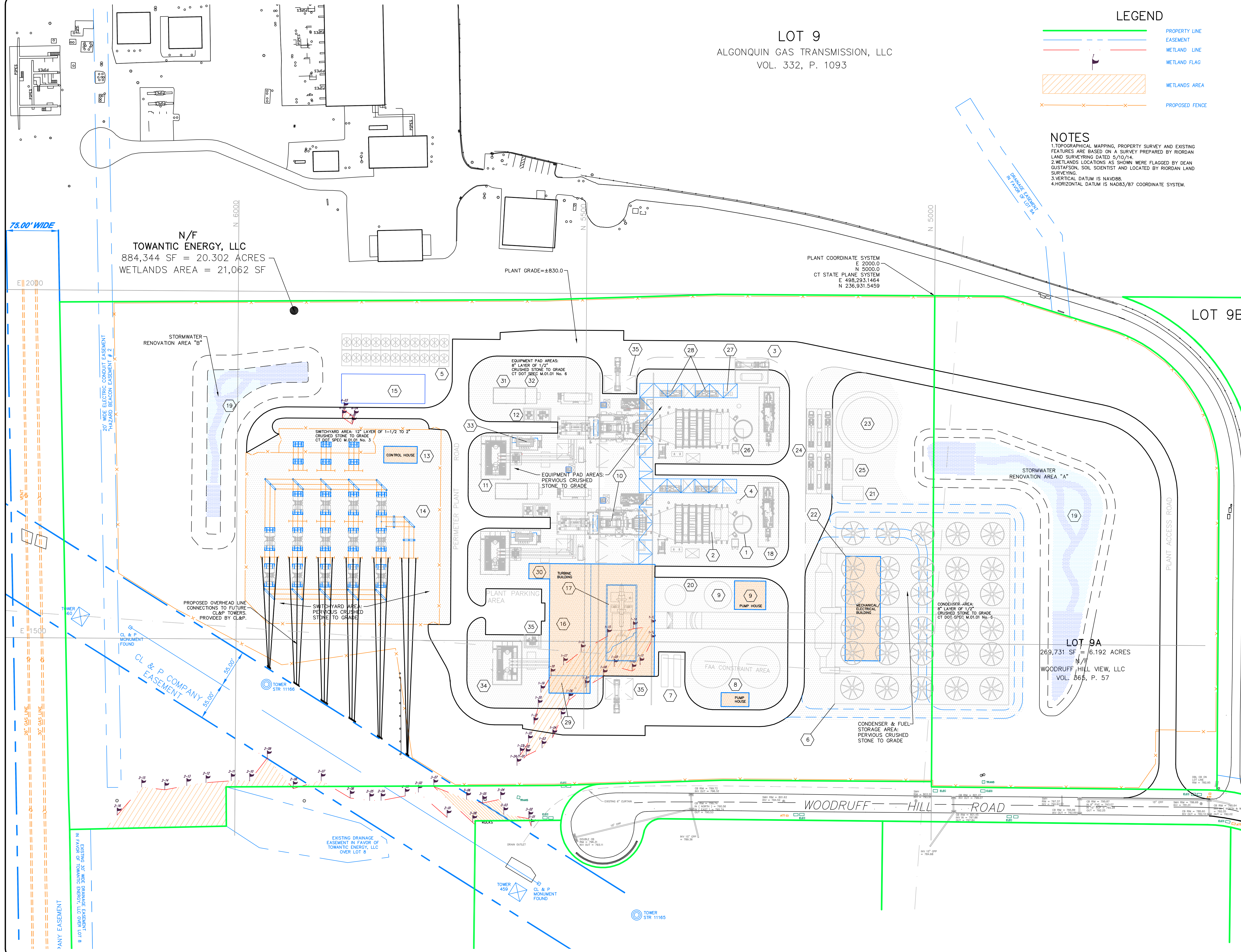

LOT 9
ALGONQUIN GAS TRANSMISSION, LLC
VOL. 332, P. 1093

LEGEND

- PROPERTY LINE
- EXISTING CONTOUR
- PROPOSED CONTOUR
- PROPOSED SPOT ELEVATION
- TREE LINE
- PROPOSED STORM DRAINAGE
- WETLAND LINE
- WETLAND FLAG
- WETLANDS AREA
- EASEMENT
- EXISTING FENCE
- PROPOSED FENCE

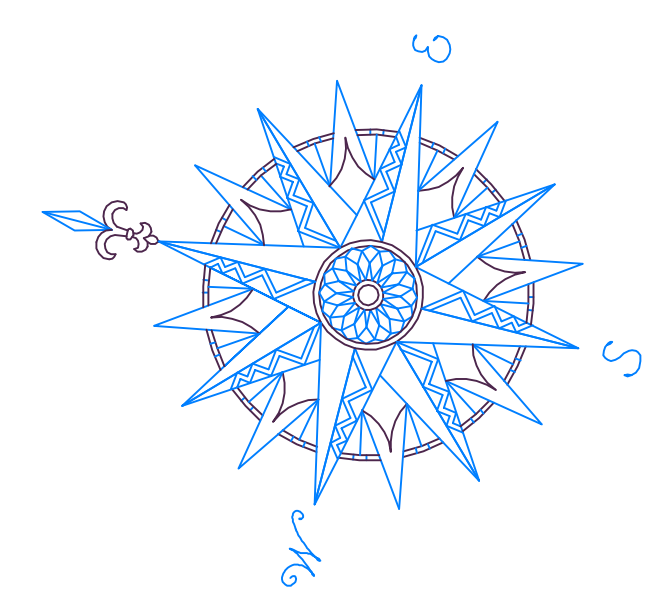

NOTES

1. TOPOGRAPHICAL MAPPING, PROPERTY SURVEY AND EXISTING FEATURES ARE BASED ON A SURVEY PREPARED BY RIORDAN LAND SURVEYING DATED 5/10/14.
2. WETLANDS LOCATIONS AS SHOWN WERE FLAGGED BY DEAN GUSTAFSON, SOIL SCIENTIST AND LOCATED BY RIORDAN LAND SURVEYING.
3. VERTICAL DATUM IS NAVD83.
4. HORIZONTAL DATUM IS NAD83/87 COORDINATE SYSTEM.

NO.	REVISION	DATE
1	REV. PER SITING COUNCIL REVIEW	02 FEB 15
2	RIPRAP PAD ADDED	18 FEB 15
3	REV. PER CT DEEP REVIEW	24 FEB 15

Previous Editions Obsolete

LEGEND-POWER PLANT

1. STACK
2. HRSG
3. AQUEOUS AMMONIUM STORAGE TANK/UNLOADING AREA
4. BLOWDOWN TANK
5. AUXILIARY COOLING SYSTEM FAN COOLER
6. AIR COOLED CONDENSER
7. DEMINERALIZED WATER TRAILERS
8. DEMINERALIZED WATER STORAGE TANKS/PUMP HOUSE (TWO (2) TANKS EACH 875,000 GALS.)
9. FIRE/SERVICE WATER STORAGE TANK & PUMP HOUSE
10. COMBUSTION TURBINE GENERATOR
11. CTG STEP-UP TRANSFORMER
12. ISOLATION TRANSFORMER/ EXCITATION TRANSFORMER
13. CONTROL HOUSE
14. SWITCHYARD
15. GAS METERING STATION
16. ELECTRICAL/BATTERY DIESEL GEN. ROOMS GND FLR
17. STEAM TURBINE GENERATOR WITH ENCLOSURE
18. GAS HEATER/FILTER AND METERING
19. STORM WATER DETENTION POND
20. CONDENSATE STORAGE TANK
21. FIRE PROTECTION FOAM SYSTEM ENCLOSURE
22. ACC MECHANICAL/ELECTRICAL BUILDING
23. FUEL OIL STORAGE TANK WITH SECONDARY STEEL CONTAINMENT (1,500,000 GAL.)
24. FUEL OIL UNLOADING AREA
25. FUEL OIL FORWARDING PUMP/HEATER/FILTER SKID
26. CEMS ENCLOSURE
27. HRSG CHEM FEED
28. BOILER FEED WATER PUMPS
29. AUXILIARY BOILER ROOM (GROUND FLOOR)
30. EMERGENCY DIESEL GENERATOR ROOM
31. LOAD COMMUTATING INVERTER (LCI) COMPARTMENT
32. COLD LINK REACTOR
33. GENERATOR EXCITATION COMPARTMENT
34. STG STEP-UP TRANSFORMER
35. EQUIPMENT REMOVAL AREA

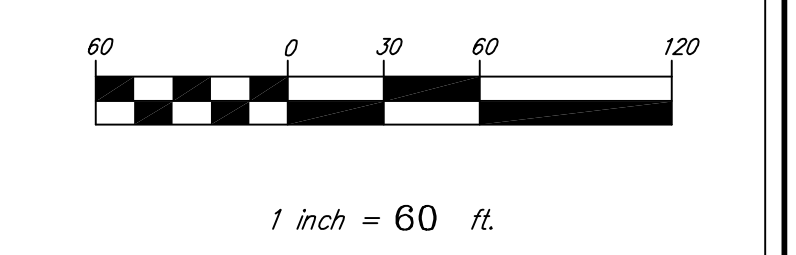

STORMWATER MANAGEMENT & GRADING PLAN

CPV TOWANTIC ENERGY CENTER

OXFORD CONNECTICUT



WOODBURY CONNECTICUT

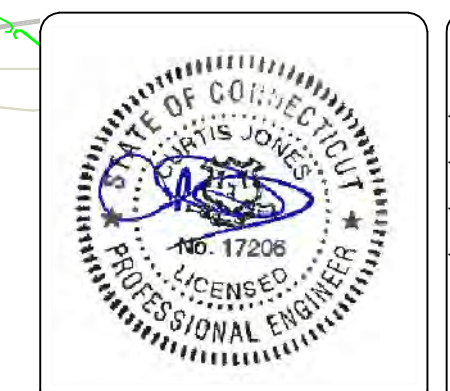

DRAWN: BB APPROVED: CJ
SCALE: 1" = 60'
DATE: 26 SEP 14
PROJ. NO.: 98132
CADD FILE NAME: 98132
DRAWING NO.: C 310

N/F
TOWANTIC ENERGY, LLC
884,344 SF = 20.302 ACRES
WETLANDS AREA = 21,062 SF

STORMWATER RENOVATION AREA "B"
EXTENDED DETENTION SHALLOW WETLAND
POOL ELEVATION 821.00
BERM ELEVATION 829.9
100 YEAR ELEVATION 824.86

WETLAND 4 IMPACT
AREA = 178 SF

WETLAND 1 IMPACT
AREA = 10,322 SF

LOT 9A
269,733 SF = 6.192 ACRES
N/F
WOODRUFF HILL VIEW, LLC
VOL. 365, P. 157

PERMANENT WETLAND IMPACTS	WETLANDS ID	IMPACT AREA (SF)
1	10,322	
4	178	
TOTAL		10,500 (0.24 AC.)

TOWER STR 11165

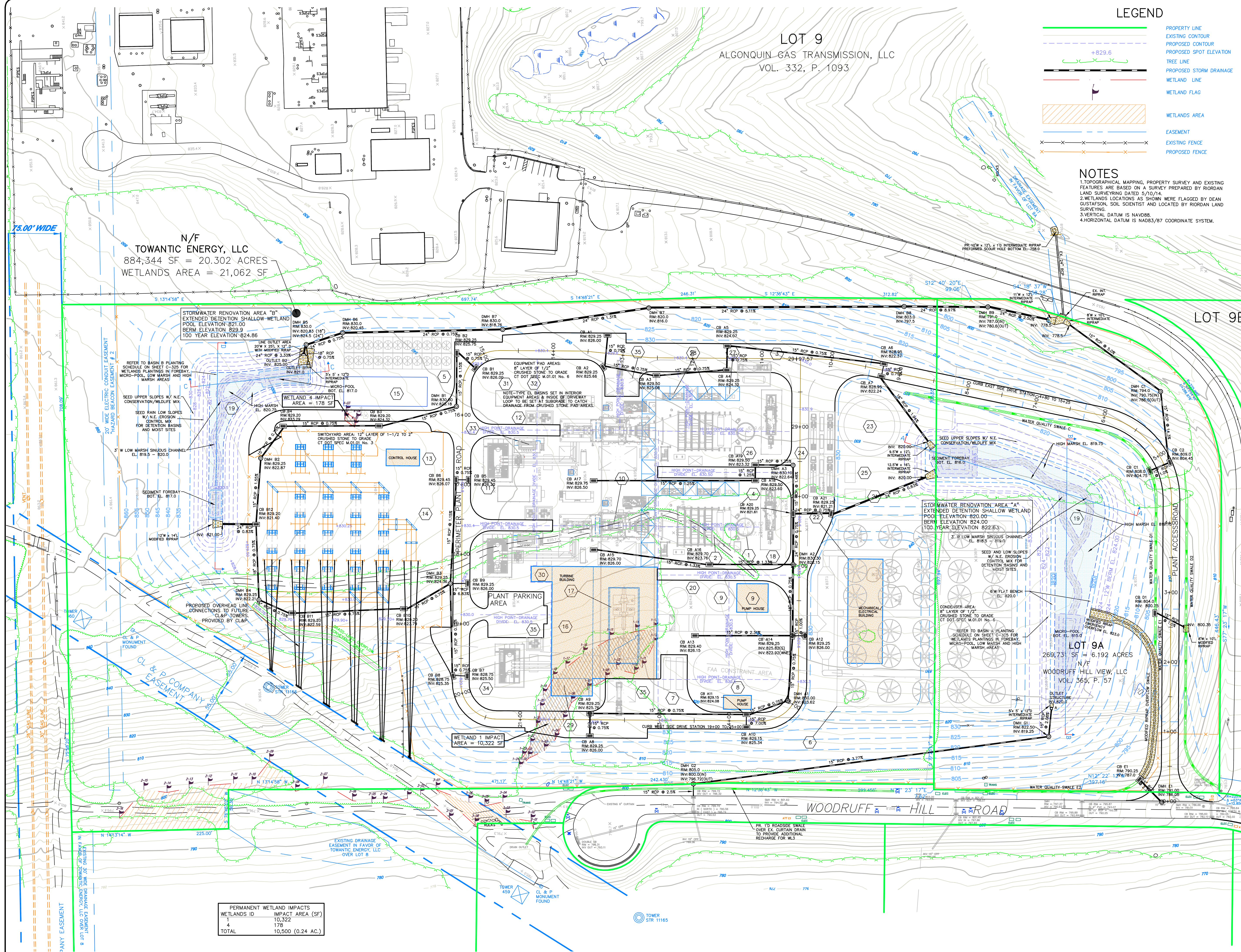

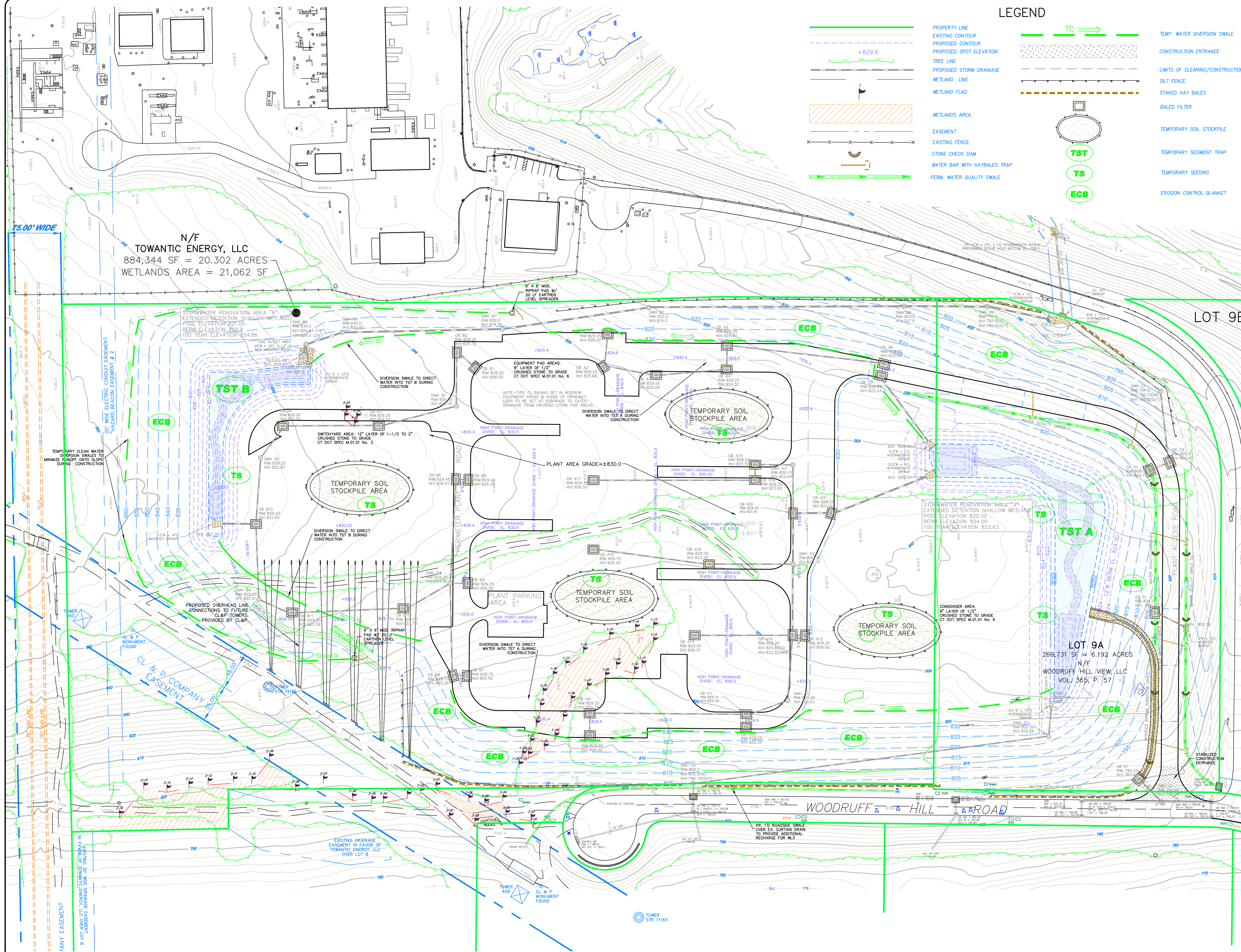

LEGEND

- PROPERTY LINE
- EXISTING CONTOUR
- PROPOSED CONTOUR
- PROPOSED SPOT ELEVATION
- TREE LINE
- PROPOSED STORM DRAINAGE
- WETLAND LINE
- WETLAND FLAG
- WETLANDS AREA
- EASEMENT
- EXISTING FENCE
- STONE CHECK DAM
- WATER BAR WITH HAYBALES TRAP
- PERM. WATER QUALITY SWALE
- TD
- TEMP. WATER DIVERSION SWALE
- CONSTRUCTION ENTRANCE
- LIMITS OF CLEARING/CONSTRUCTION
- SILT FENCE
- STAKED HAY BALES
- BALED FILTER
- TEMPORARY SOIL STOCKPILE
- TEMPORARY SEDIMENT TRAP
- TEMPORARY SEEDING
- EROSION CONTROL BLANKET

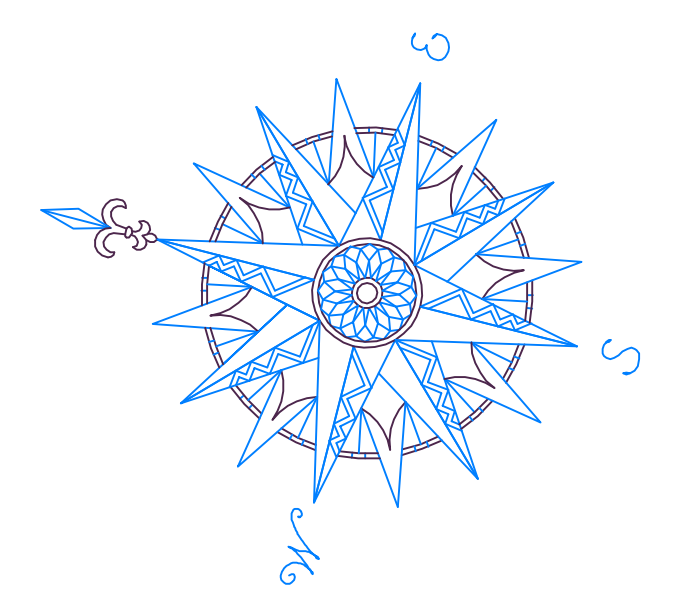

NO.	REVISION	DATE
1	REV. PER SITING COUNCIL REVIEW	13 FEB 15
2	REV. PER CT DEEP REVIEW	24 FEB 15
Previous Editions Obsolete		

LOT 9B

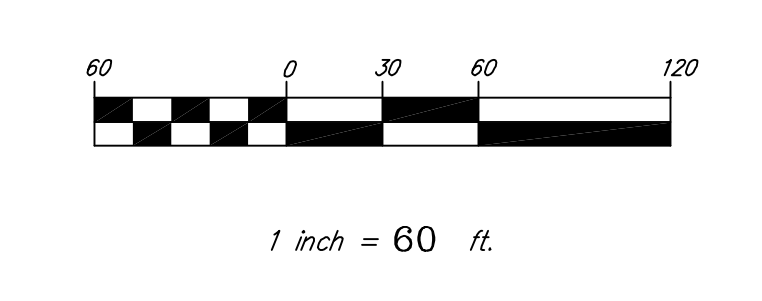

EROSION & SEDIMENT CONTROL PLAN

CPV TOWANTIC ENERGY CENTER

OXFORD CONNECTICUT

Civil 1
 CORNERSTONE PROFESSIONAL PARK, SUITE D-101
 43 SHERMAN HILL ROAD
 WOODBURY CONNECTICUT
 (203) 266-0778



DRAWN: BB APPROVED: CJ
 SCALE: 1" = 60'
 DATE: 26 SEP 14
 PROJ. NO.: 98132
 CAD FILE NAME: 98132
 DRAWING NO.: **C 315**

N/F
 TOWANTIC ENERGY, LLC
 884,344 SF = 20.302 ACRES
 WETLANDS AREA = 21,062 SF

LOT 9A
 269,731 SF = 6.192 ACRES
 N/F
 WOODRUFF HILL VIEW, LLC
 VOL. 365, P. 157

WOODRUFF HILL ROAD

TOWER STR 11165

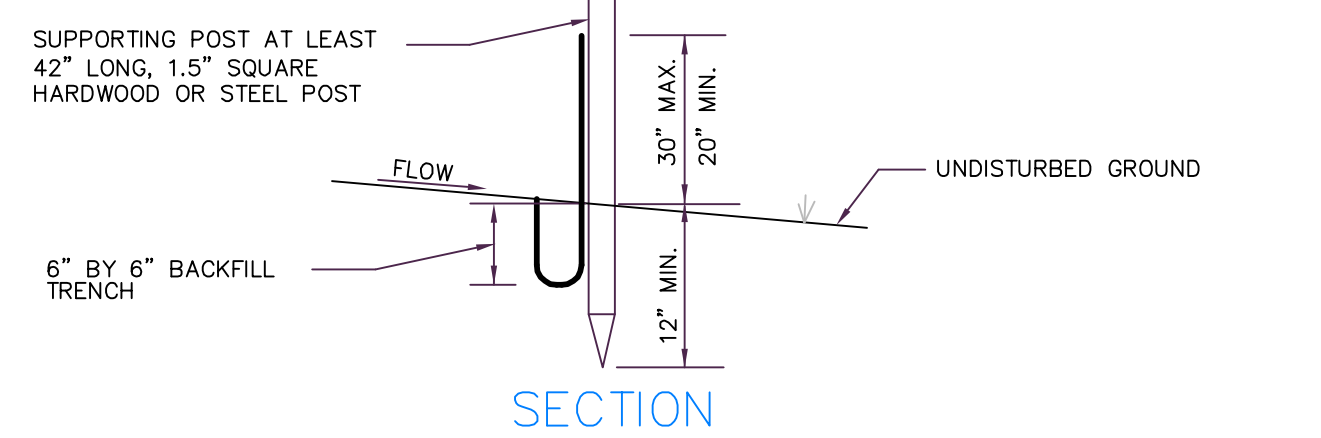
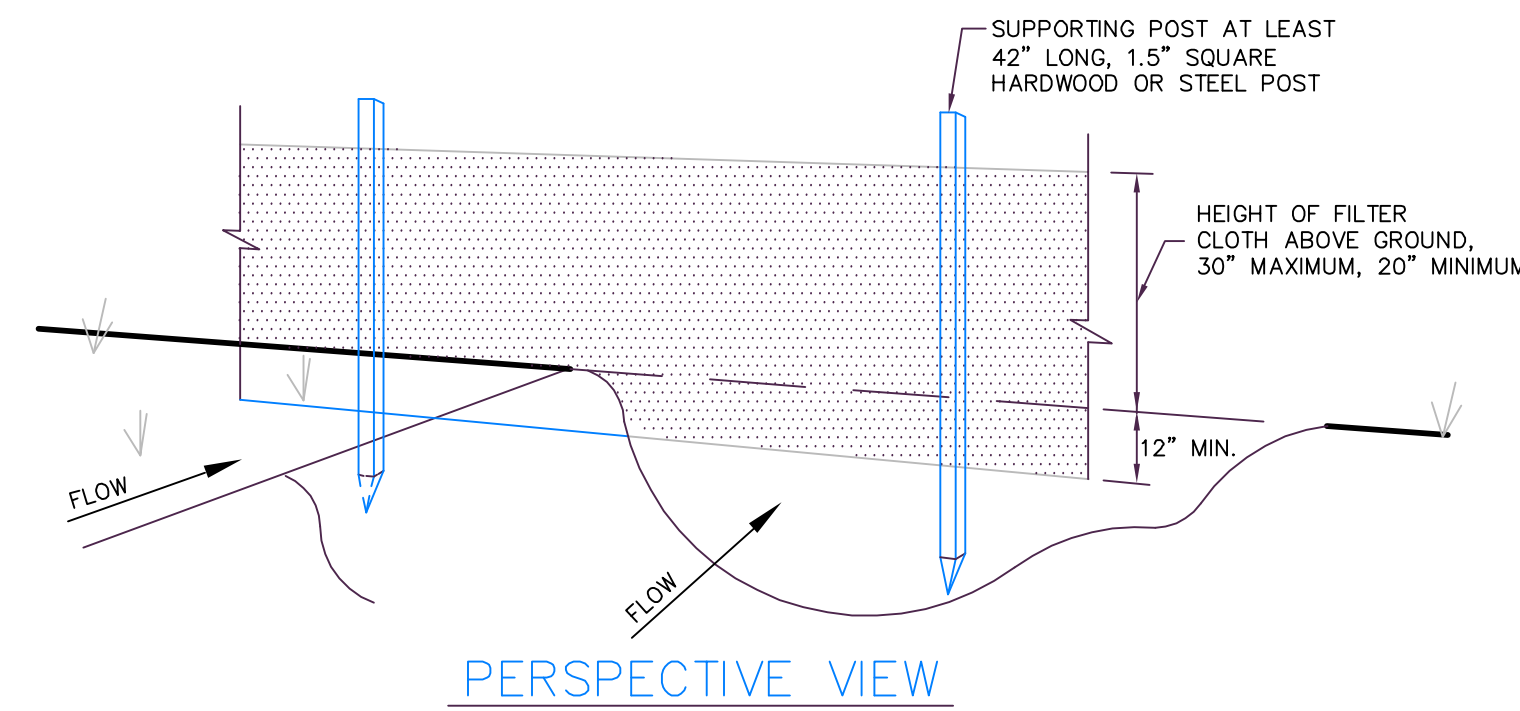

CONSTRUCTION NOTES FOR SILT FENCE

1. EXCAVATE A TRENCH A MINIMUM OF 6 INCHES DEEP AND 6 INCHES WIDE ON THE UP SIDE OF THE FENCE LOCATION.
 2. DRIVE SUPPORT POSTS ON THE DOWN SLOPE SIDE OF THE TRENCH TO A DEPTH OF AT LEAST 12 INCHES INTO ORIGINAL GROUND.
 3. STAPLE OR SECURE THE GEOTEXTILE TO THE SUPPORT POSTS PER MANUFACTURER'S INSTRUCTIONS SUCH THAT AT LEAST 6 INCHES OF GEOTEXTILE LIES WITHIN THE TRENCH.
 4. BACKFILL THE TRENCH WITH TAMPED SOIL OR AGGREGATE OVER THE GEOTEXTILE.
- POSTS: 1.5" SQUARE HARDWOOD OR STEEL
- FILTER CLOTH: MIRAFI 100X, ENVIROFENCE OR APPROVED EQUAL

SILT FENCE DETAIL
N.T.S.

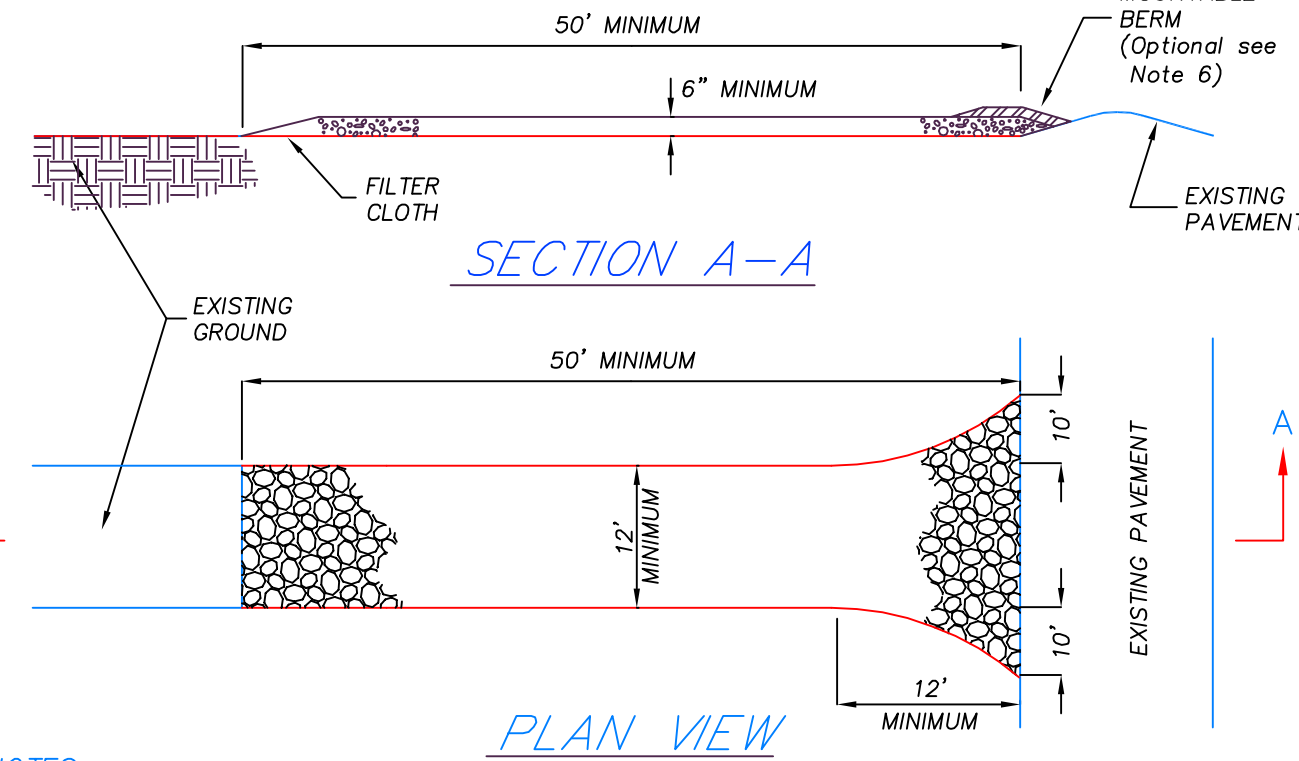
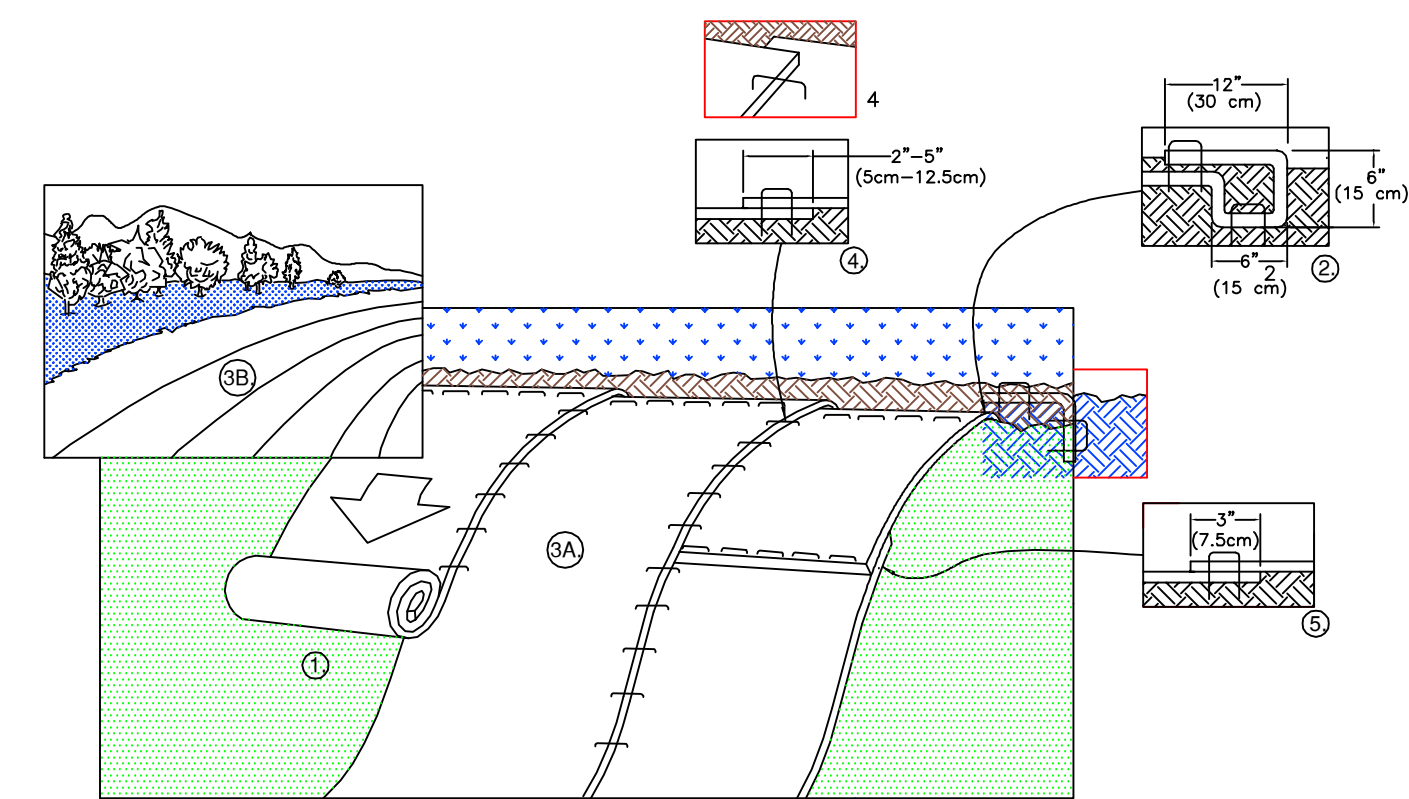

- NOTES:**
1. STONE SIZE - USE 1" - 2" STONE, OR RECLAIMED OR RECYCLED CONCRETE EQUIVALENT.
 2. LENGTH - AS REQUIRED, BUT NOT LESS THAN 50 FEET.
 3. THICKNESS - NOT LESS THAN SIX (6) INCHES.
 4. WIDTH - 12 FOOT MINIMUM, BUT NOT LESS THAN THE FULL WIDTH AT POINTS WHERE INGRESS OR EGRESS OCCURS. 24 FOOT MINIMUM IF SINGLE ENTRANCE TO SITE.
 5. FILTER CLOTH - TO BE PLACED OVER THE ENTIRE AREA PRIOR TO PLACING OF STONE.
 6. SURFACE WATER - ALL SURFACE WATER FLOWING OR DIVERTED TOWARD CONSTRUCTION ENTRANCES SHALL BE PIPED ACROSS THE ENTRANCE. IF PIPING IS IMPRACTICAL, A MOUNTABLE BERM WITH 5:1 SLOPES WILL BE PERMITTED.
 7. MAINTENANCE - THE ENTRANCE SHALL BE MAINTAINED IN A CONDITION WHICH WILL PREVENT TRACKING OF FLOWING OF SEDIMENT ONTO PUBLIC RIGHTS-OF-WAY. THIS MAY REQUIRE PERIODIC TOP DRESSING WITH ADDITIONAL STONE AS CONDITIONS DEMAND AND REPAIR AND/OR CLEANOUT OF ANY MEASURE USED TO TRAP SEDIMENT. ALL SEDIMENT SPILLED, DRIPPED, WASHED OR TRACKED ONTO PUBLIC RIGHTS-OF-WAY MUST BE REMOVED IMMEDIATELY.
 8. WASHING - WHEELS SHALL BE CLEANED TO REMOVE SEDIMENT PRIOR TO ENTRANCE ONTO PUBLIC RIGHTS-OF-WAY. WHEN WASHING IS REQUIRED, IT SHALL BE DONE ON AN AREA STABILIZED WITH STONE AND WHICH DRAINS INTO AN APPROVED SEDIMENT TRAPPING DEVICE.
 9. PERIODIC INSPECTION AND NEEDED MAINTENANCE SHALL BE PROVIDED AFTER EACH RAIN.

STABILIZED CONSTRUCTION ENTRANCE
N.T.S.

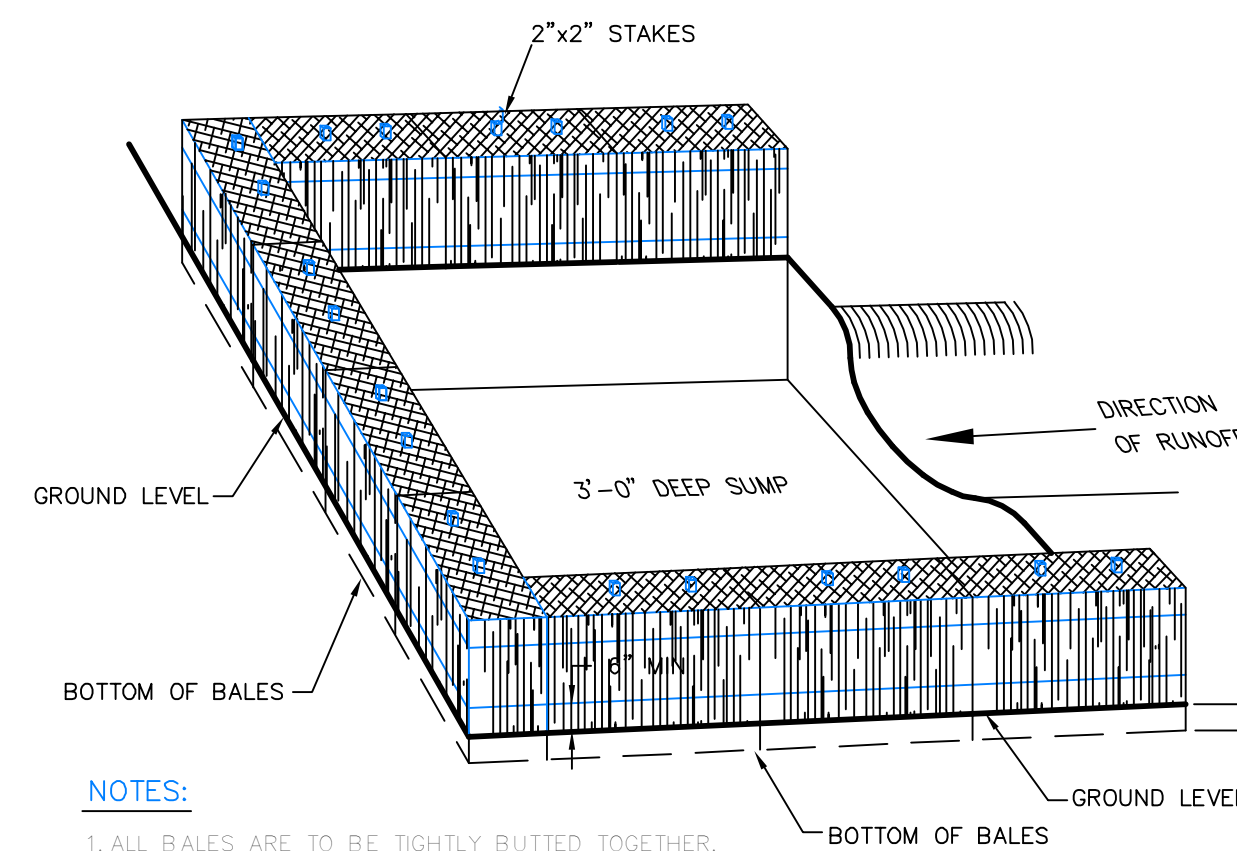

WATER BAR - TEMPORARY DIVERSION DITCH WITH HAYBALE TRAP
N.T.S.

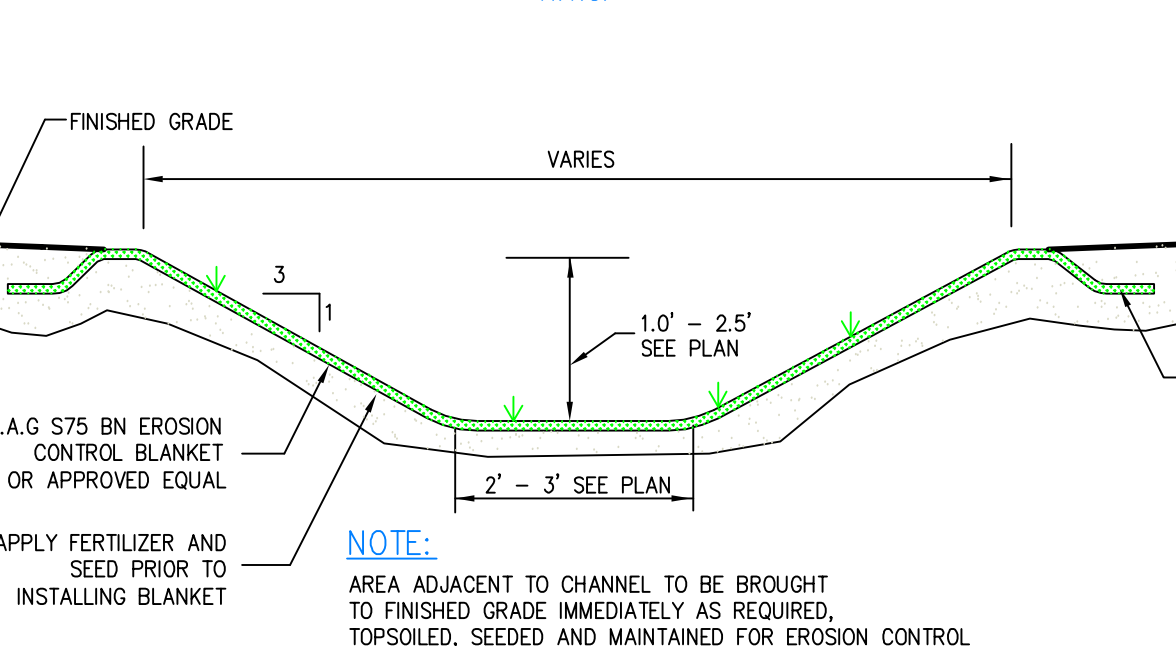

WATER QUALITY & GRASS LINED CONVEYANCE SWALES
N.T.S.

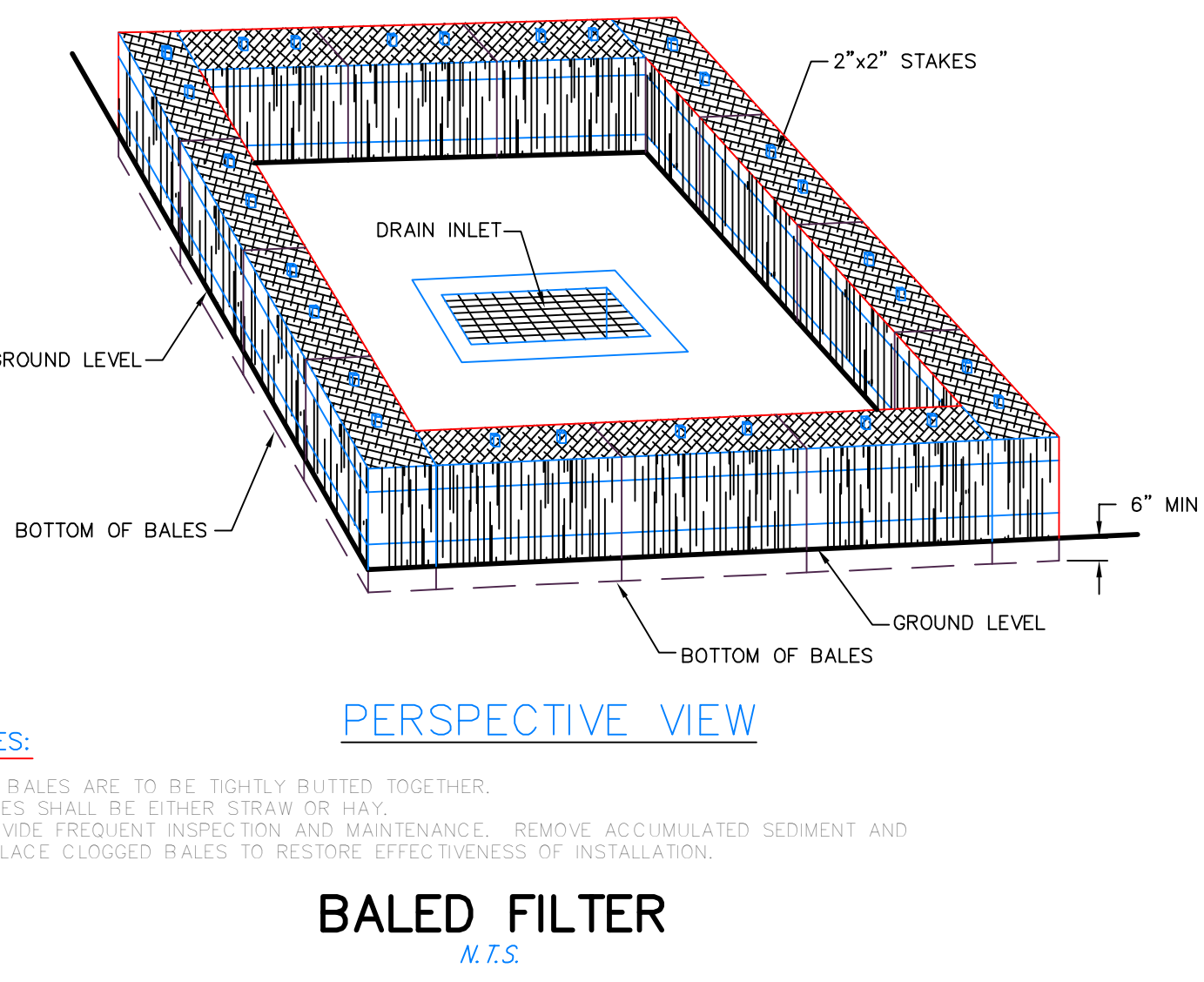
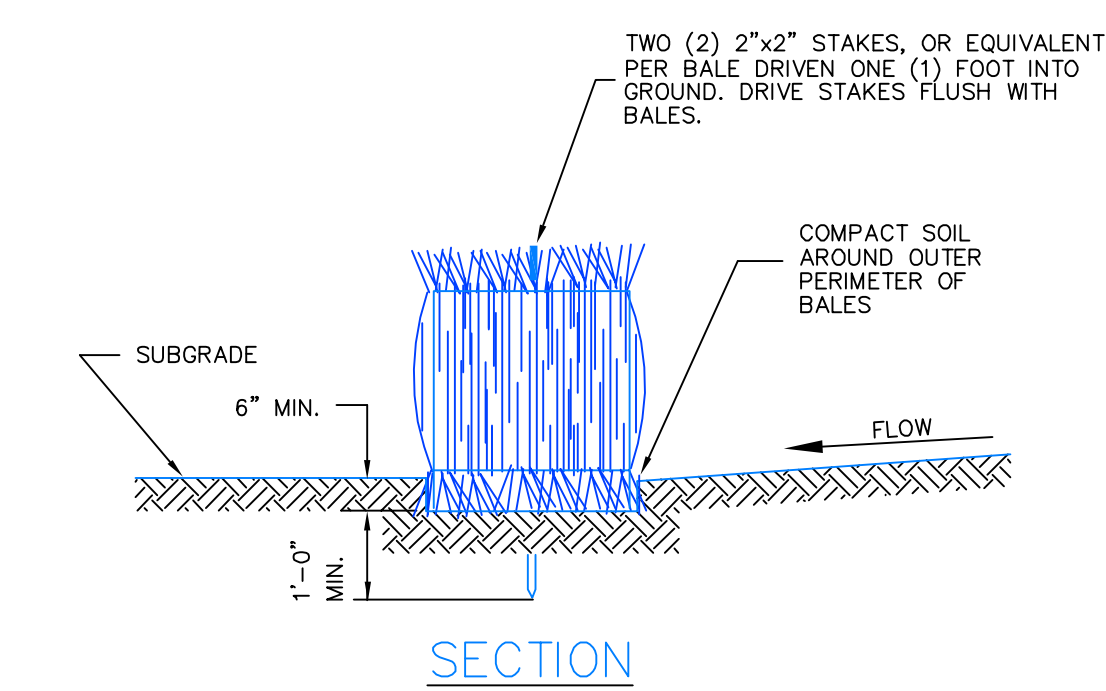
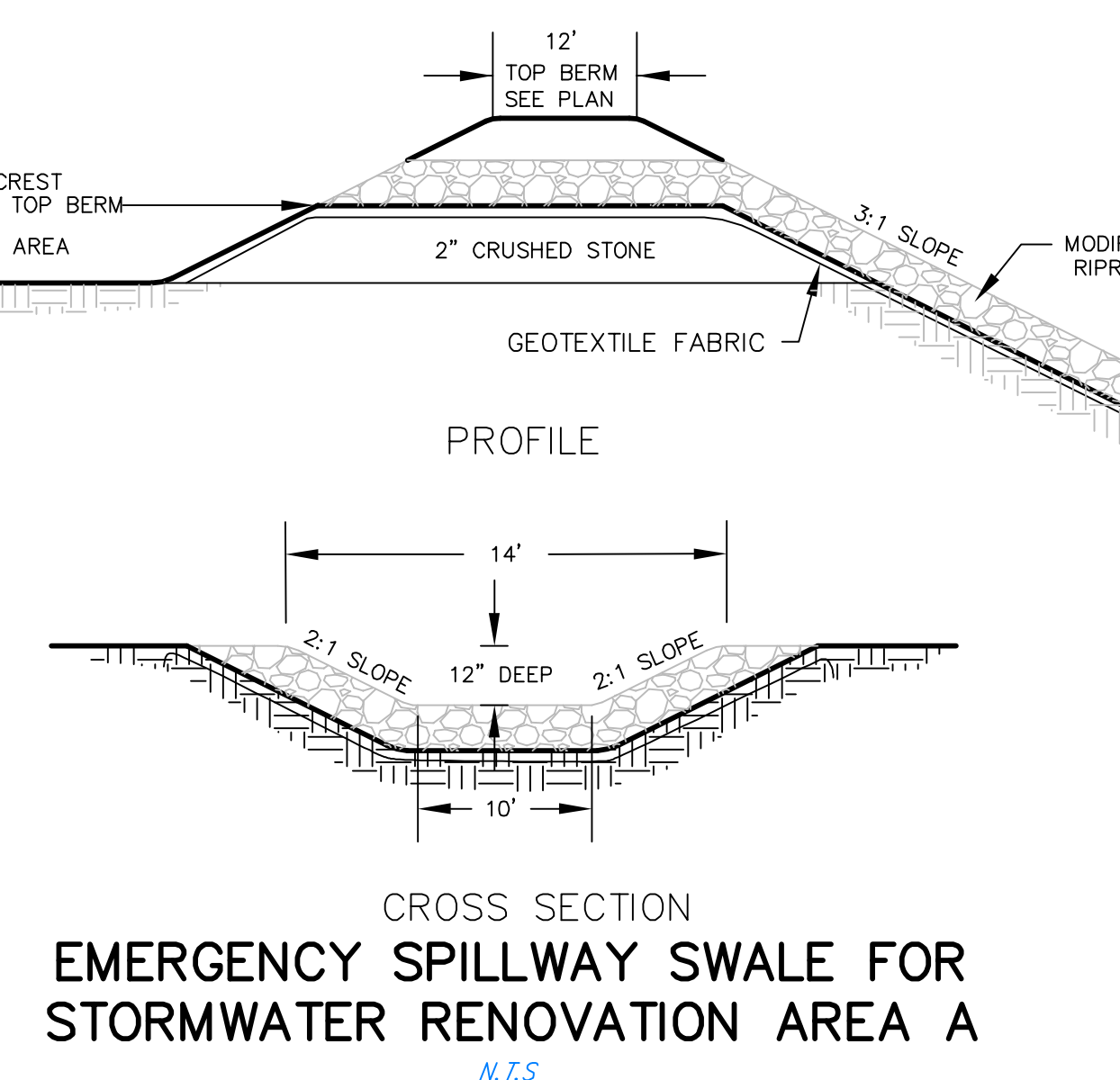
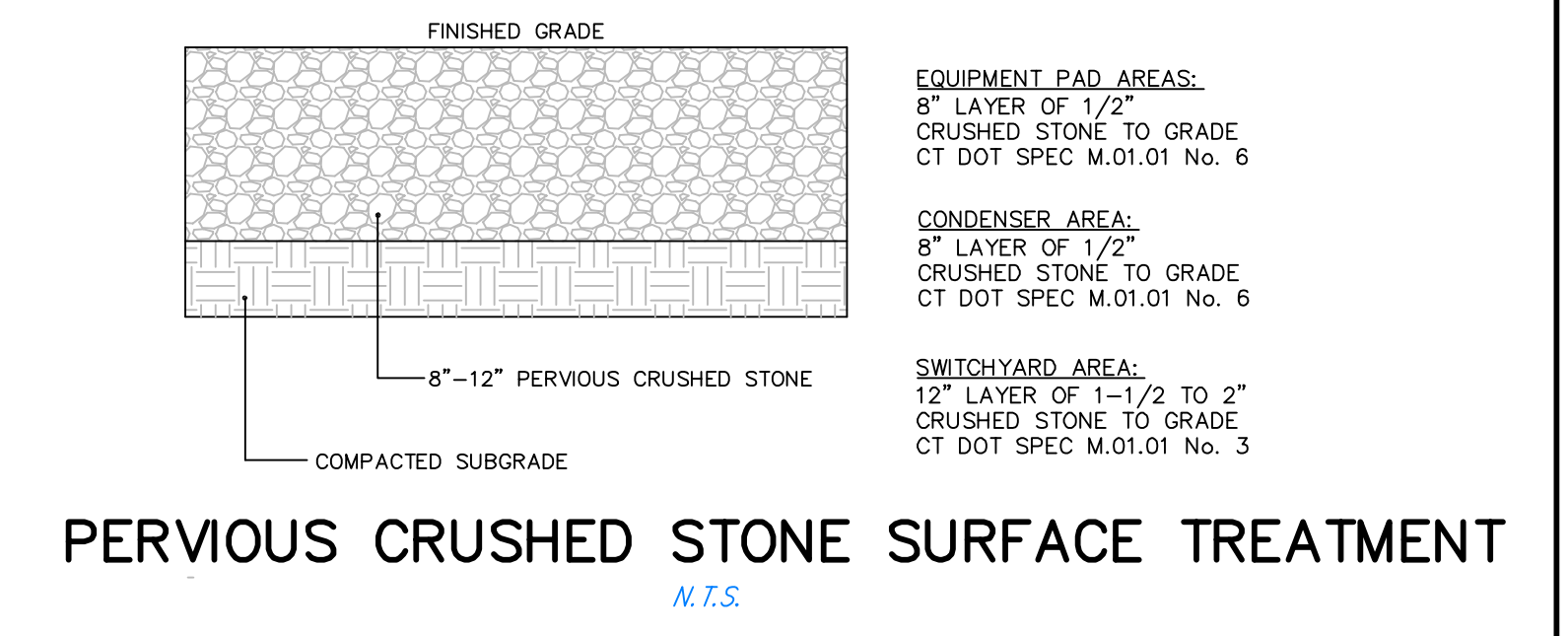
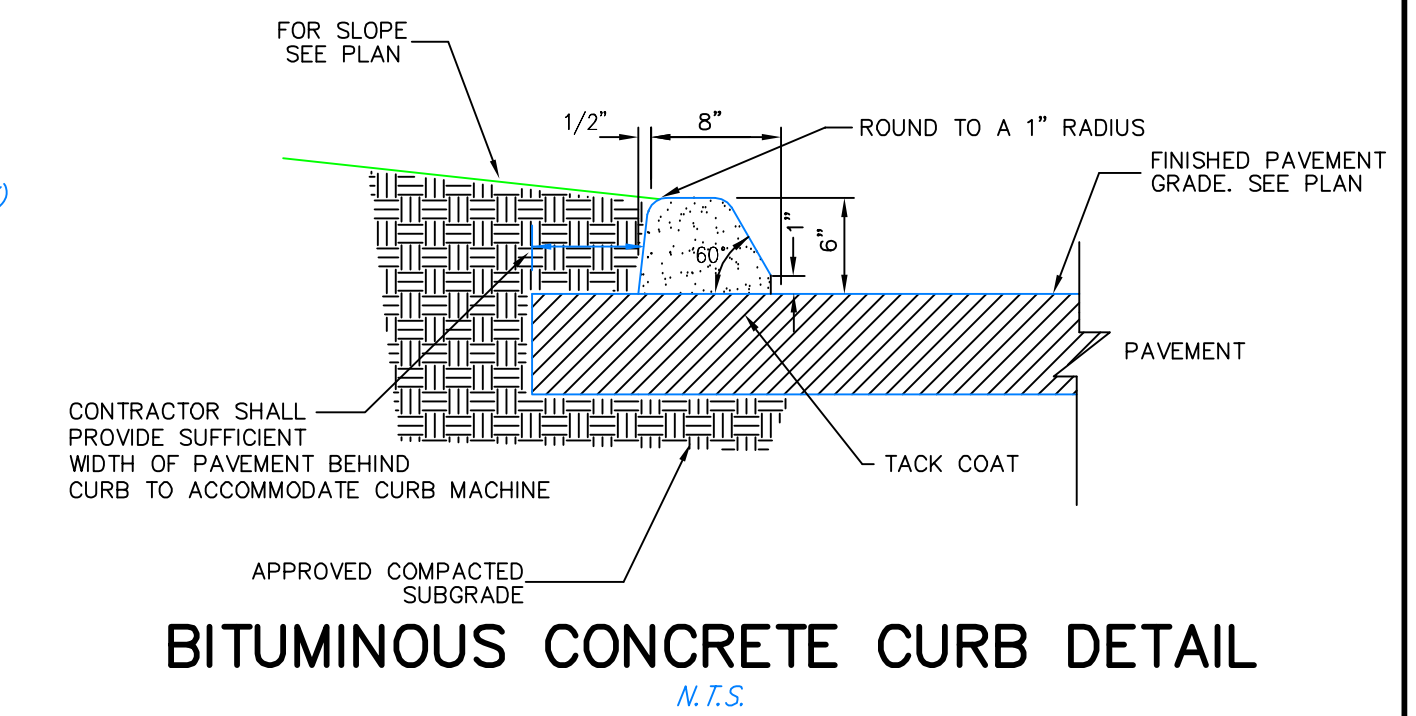
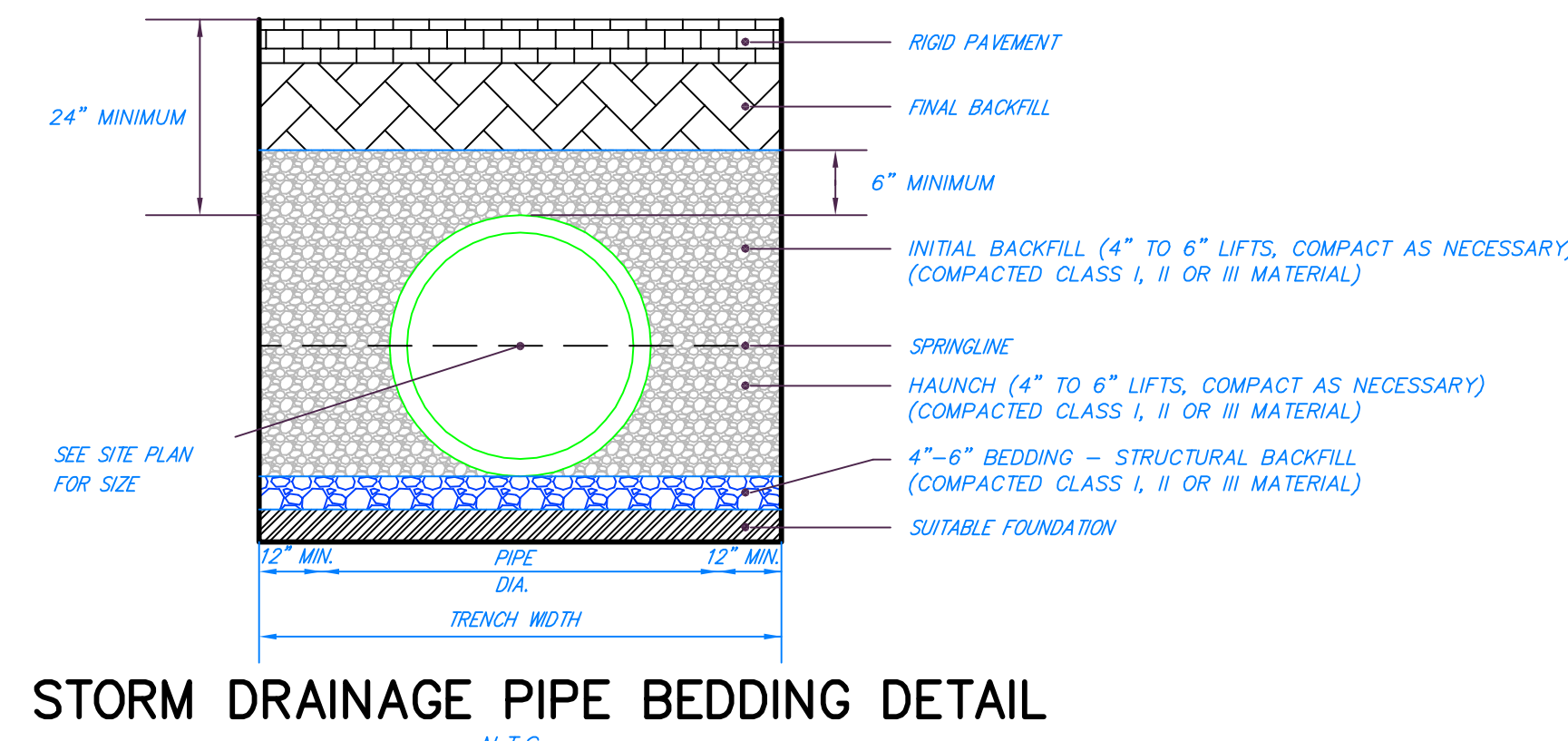
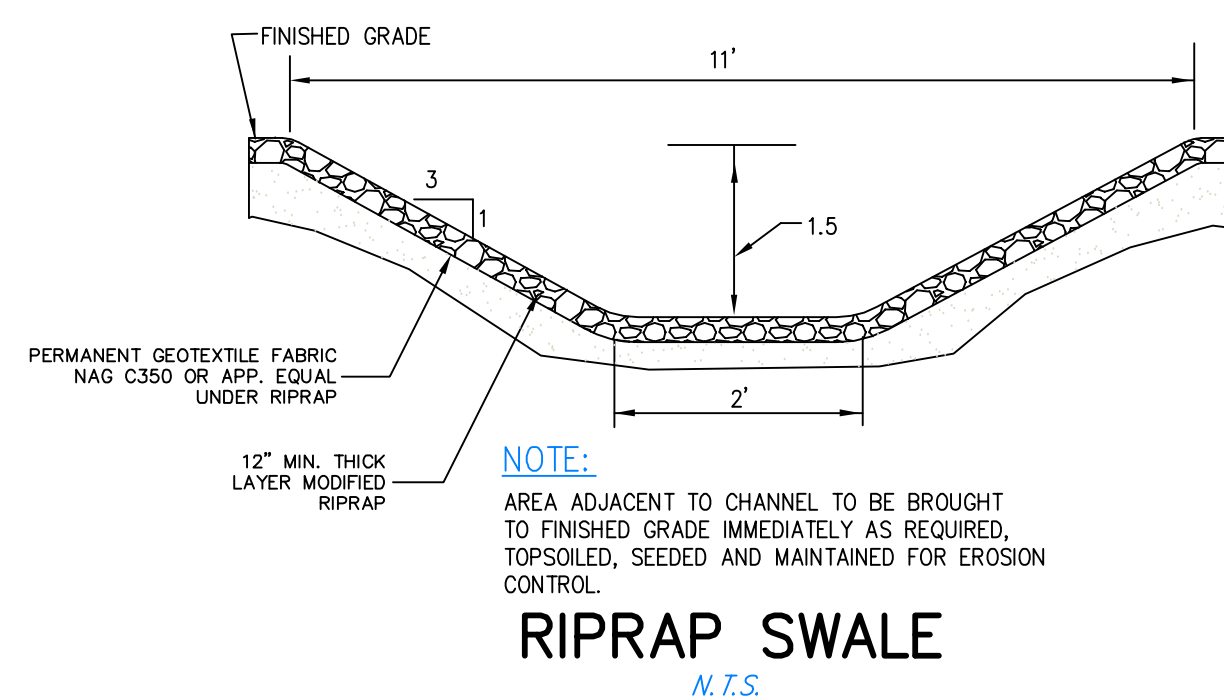

- NOTES:**
1. ALL BALES ARE TO BE TIGHTLY BUTTED TOGETHER.
 2. BALES SHALL BE EITHER STRAW OR HAY.
 3. PROVIDE FREQUENT INSPECTION AND MAINTENANCE. REMOVE ACCUMULATED SEDIMENT AND REPLACE CLOGGED BALES TO RESTORE EFFECTIVENESS OF INSTALLATION.

NO.	REVISION	DATE
1	REV. PER SITING COUNCIL REVIEW	13 FEB 15

Previous Editions Obsolete

DETAILS

CPV TOWANTIC ENERGY CENTER

OXFORD CONNECTICUT



CORNERSTONE PROFESSIONAL PARK, SUITE D-101
43 SHERMAN HILL ROAD
WOODBURY CONNECTICUT (203) 266-0778



DRAWN: BB APPROVED: CJ
SCALE: N.T.S.
DATE: 26 SEP 14
PROJ. NO.: 98132
CADD FILE NAME: 98132
DRAWING NO.:
C 320

EROSION CONTROL BLANKET
N.T.S.

1. PREPARE SOIL BEFORE INSTALLING BLANKETS, INCLUDING ANY NECESSARY APPLICATION OF LIME, FERTILIZER, AND SEED. NOTE: WHEN USING CELL-O-SEED DO NOT SEED PREPARED AREA. CELL-O-SEED MUST BE INSTALLED WITH PAPER SIDE DOWN.
 2. BEGIN AT THE TOP OF THE SLOPE BY ANCHORING THE BLANKET IN A 6" (15cm) DEEP X 6" (15cm) WIDE TRENCH WITH APPROXIMATELY 12" (30cm) OF BLANKET EXTENDED BEYOND THE UP-SLOPE PORTION OF THE TRENCH. ANCHOR THE BLANKET WITH A ROW OF STAPLES/STAKES APPROXIMATELY 12" (30cm) APART IN THE BOTTOM OF THE TRENCH. BACKFILL AND COMPACT THE TRENCH AFTER STAPLING. APPLY SEED TO COMPACTED SOIL AND FOLD REMAINING 12" (30cm) PORTION OF BLANKET BACK OVER SEED AND COMPACTED SOIL. SECURE BLANKET OVER COMPACTED SOIL WITH A ROW OF STAPLES/STAKES SPACED APPROXIMATELY 12" (30cm) APART ACROSS THE WIDTH OF THE BLANKET.
 3. ROLL THE BLANKETS (A) DOWN OR (B) HORIZONTALLY ACROSS THE SLOPE. BLANKETS WILL UNROLL WITH APPROPRIATE SIDE AGAINST THE SOIL SURFACE. ALL BLANKETS MUST BE SECURELY FASTENED TO SOIL SURFACE BY PLACING STAPLES/STAKES IN APPROPRIATE LOCATIONS AS SHOWN IN THE STAPLE PATTERN GUIDE. WHEN USING OPTIONAL DOT SYSTEM, STAPLES/STAKES SHOULD BE PLACED THROUGH EACH OF THE COLORED DOTS CORRESPONDING TO THE APPROPRIATE STAPLE PATTERN.
 4. THE EDGES OF PARALLEL BLANKETS MUST BE STAPLED WITH APPROXIMATELY 2"-5" (5cm-12.5cm) OVERLAP DEPENDING ON BLANKET TYPE. TO ENSURE PROPER SEAM ALIGNMENT, PLACE THE EDGE OF THE OVERLAPPING BLANKET (BLANKET BEING INSTALLED ON TOP) EVEN WITH THE COLORED SEAM STITCH ON THE PREVIOUSLY INSTALLED BLANKET.
 5. CONSECUTIVE BLANKETS SPLICED DOWN THE SLOPE MUST BE PLACED END OVER END (SHINGLE STYLE) WITH AN APPROXIMATE 3" (7.5cm) OVERLAP. STAPLE THROUGH OVERLAPPED AREA, APPROXIMATELY 12" (30cm) APART ACROSS ENTIRE BLANKET WIDTH.
- NOTE:
*IN LOOSE SOIL CONDITIONS, THE USE OF STAPLE OR STAKE LENGTHS GREATER THAN 6" (15cm) MAY BE NECESSARY TO PROPERLY SECURE THE BLANKETS.
- EROSION CONTROL BLANKETS**
- S75: Material:
100% straw matrix sewn into a photo-degradable net.
Straw: 5 lbs/sq. yd.
Net: Lightweight degradable (Top side only)
- S150: Material:
Straw fiber matrix sewn between two photo-degradable nets.
Straw: 5 lbs/sq. yd.
Net: Lightweight degradable (Both sides)
- CRITICAL POINTS
A. OVERLAPS AND SEAMS
B. PROJECTED WATER LINE
C. CHANNEL BOTTOM/SIDE SLOPE VERTICES
- NOTE:
* HORIZONTAL STAPLE SPACINGS SHOULD BE ALTERED IF NECESSARY TO ALLOW STAPLES TO SECURE THE CRITICAL POINTS ALONG THE CHANNEL SURFACE.
* IN LOOSE SOIL CONDITIONS, THE USE OF STAPLE OR STAKE LENGTHS IN EXCESS OF 6" (15 cm) MAY BE NECESSARY TO PROPERLY ANCHOR THE BLANKETS.

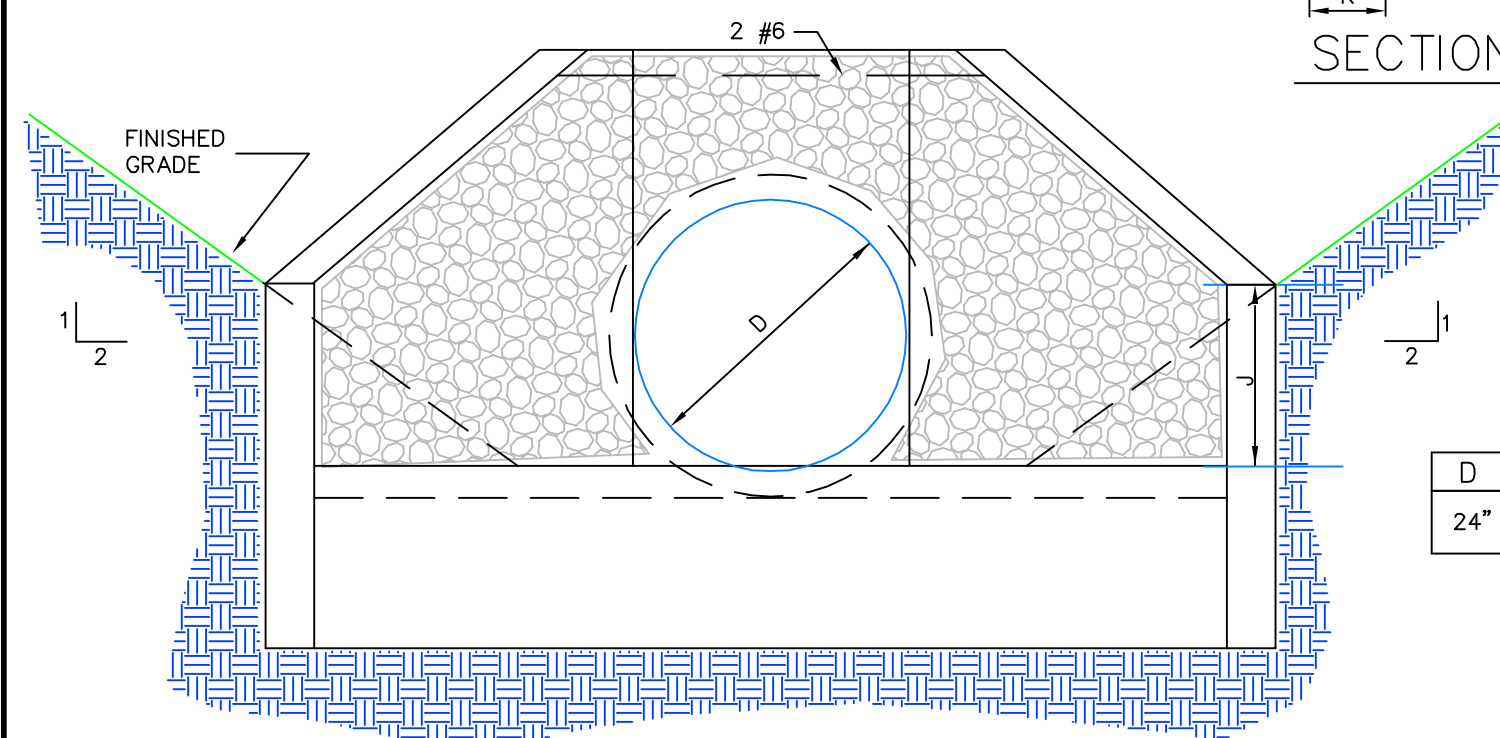
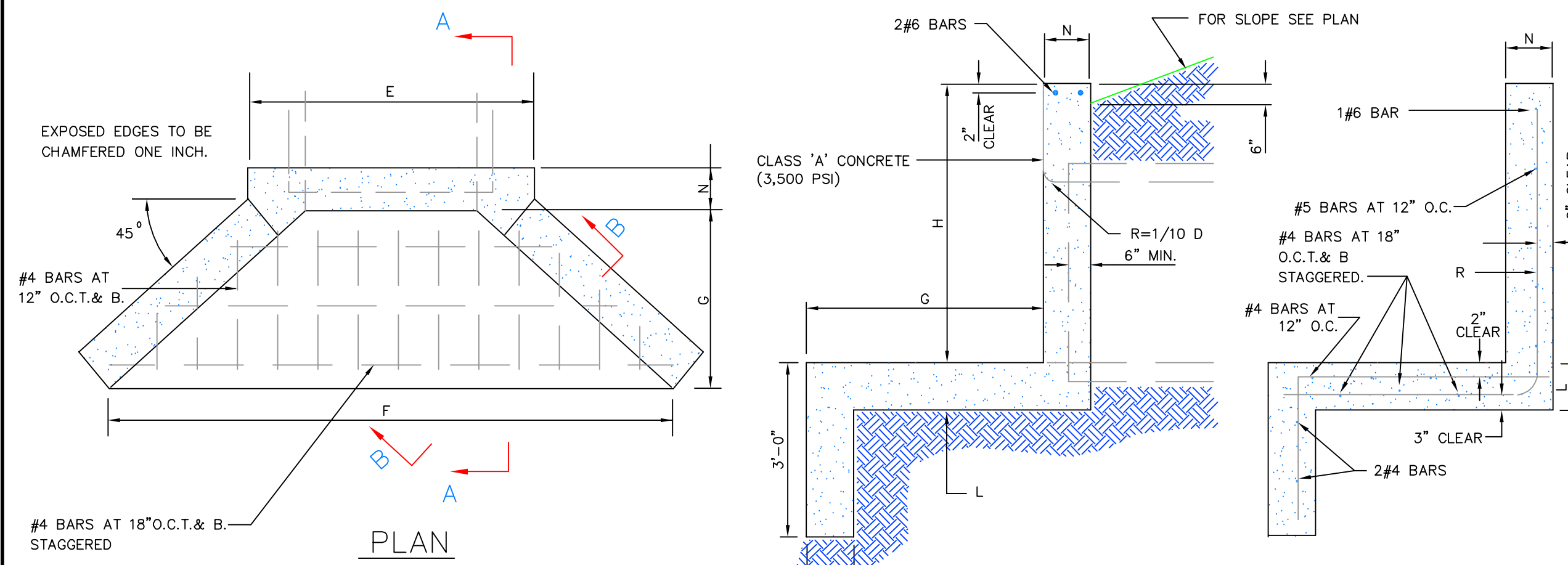
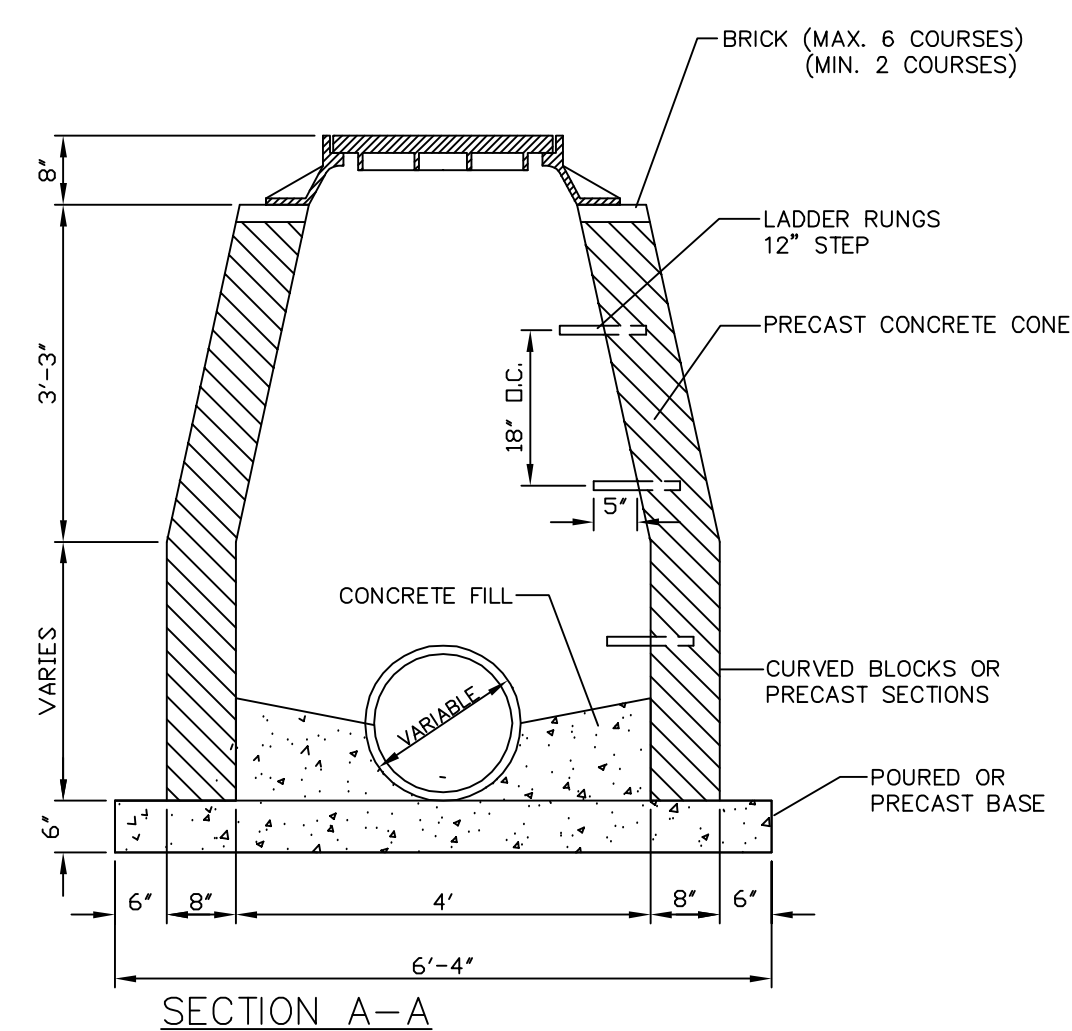
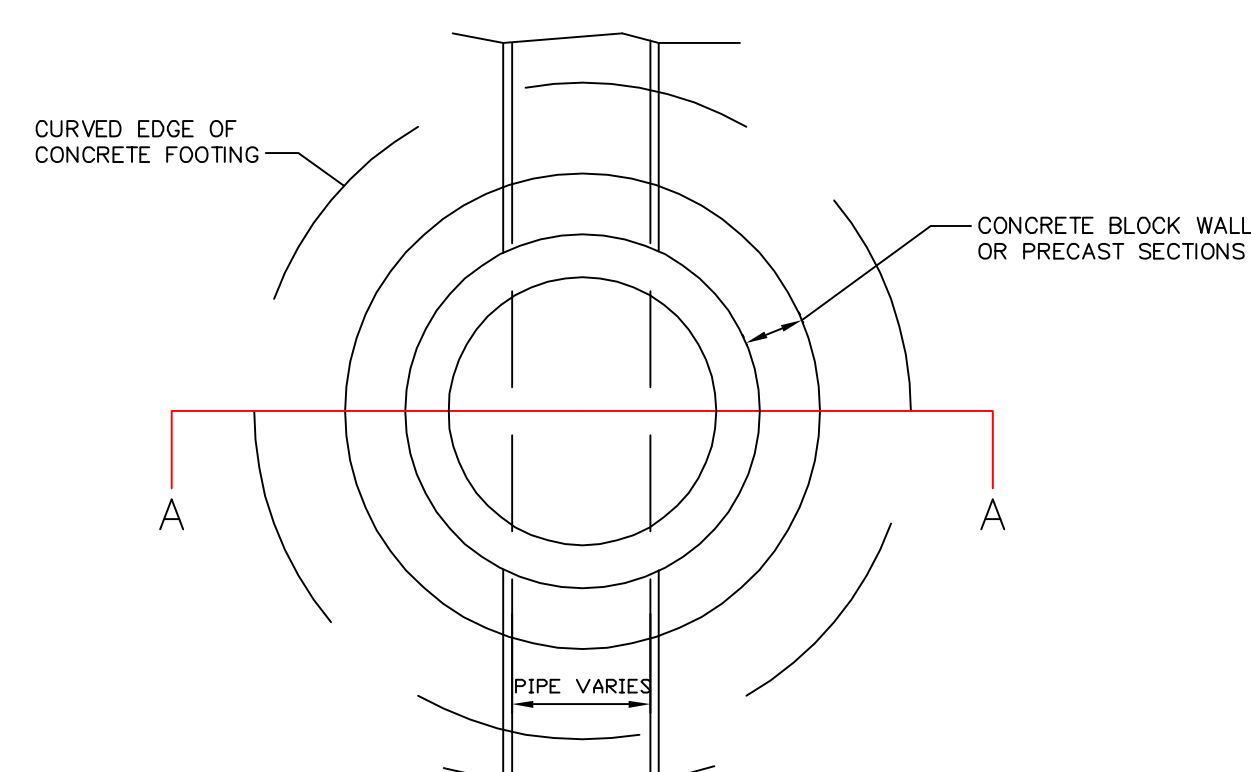

TABLE OF DIMENSIONS

D	E	F	G	H	J	K	L	R	N
24"	3'-8"	8'-0"	3'-0"	3'-6"	1'-6"	8"	8"	#5 @ 12" O.C.	8"

STORMWATER RENOVATION AREA B OUTLET STRUCTURE B2
N.T.S.



DRAINAGE MANHOLE
without sump

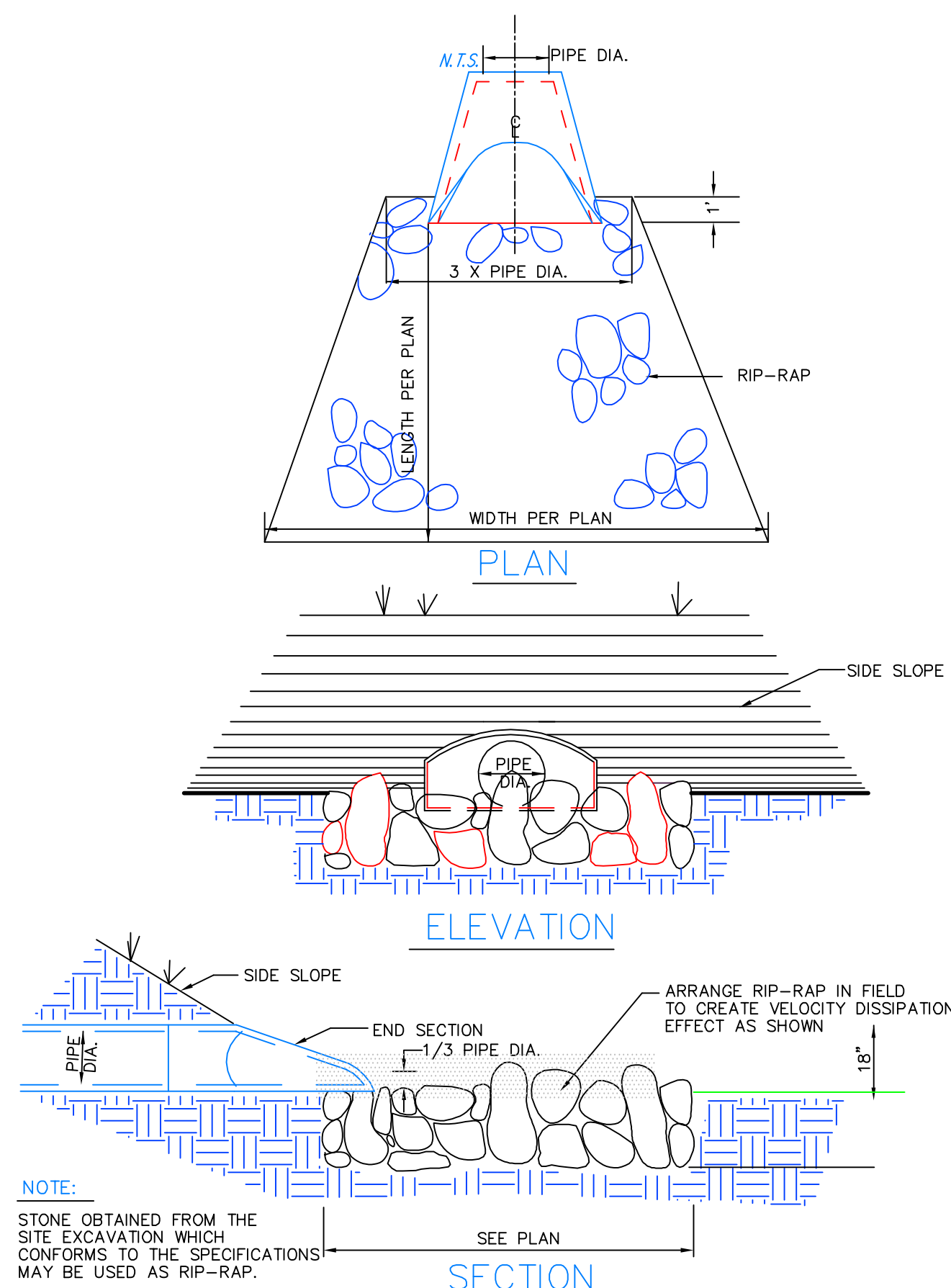

RIP-RAP OUTLET PROTECTION
N.T.S.

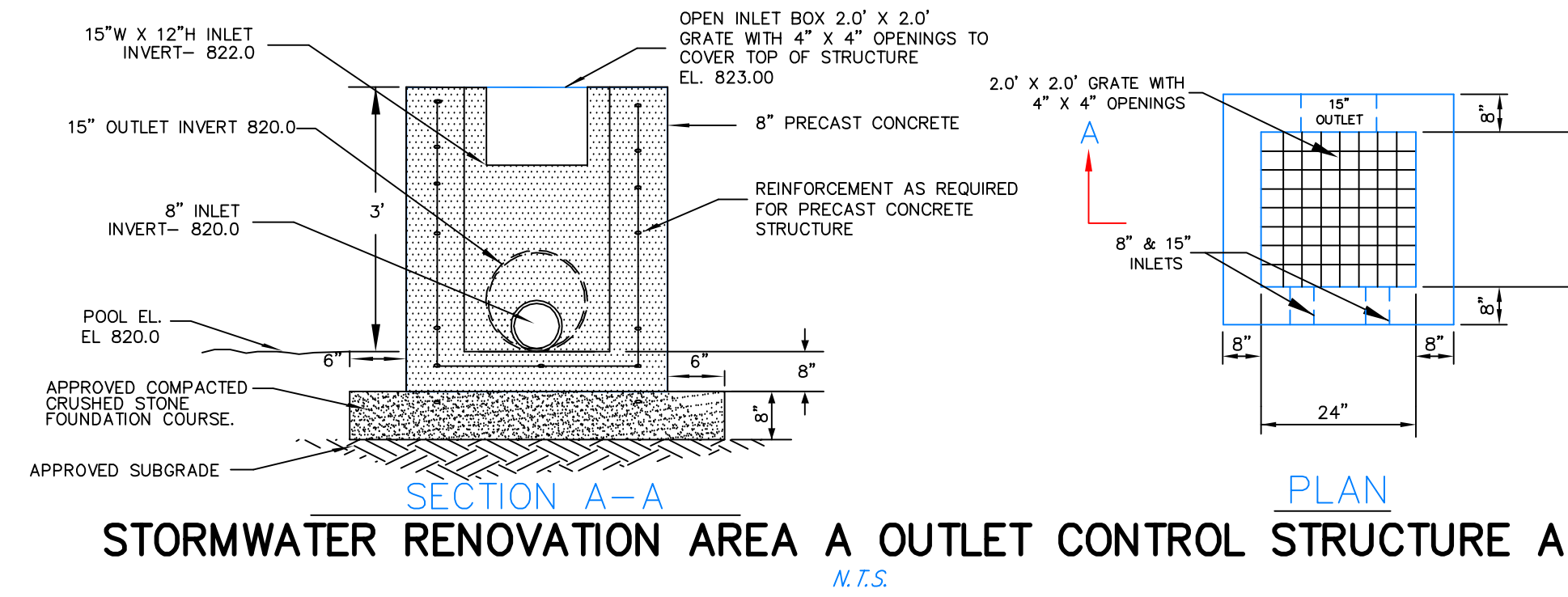

STORMWATER RENOVATION AREA A OUTLET CONTROL STRUCTURE A
N.T.S.

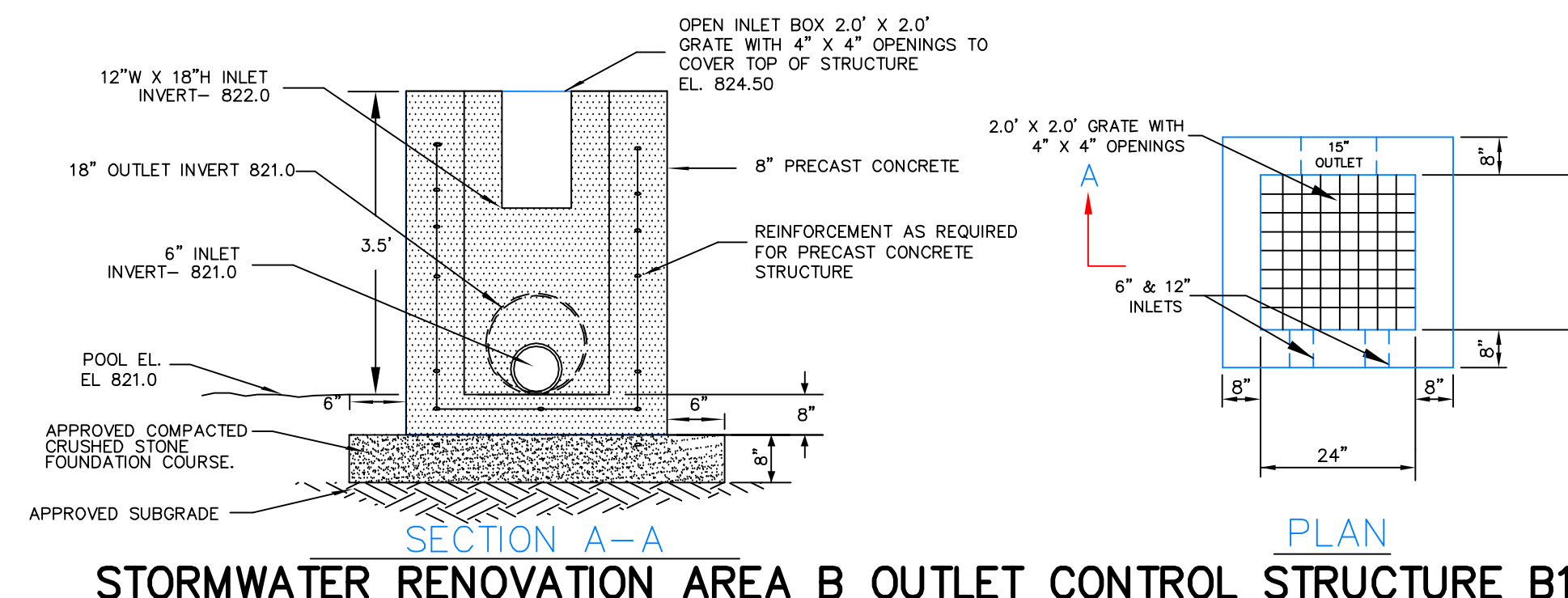

STORMWATER RENOVATION AREA B OUTLET CONTROL STRUCTURE B1
N.T.S.

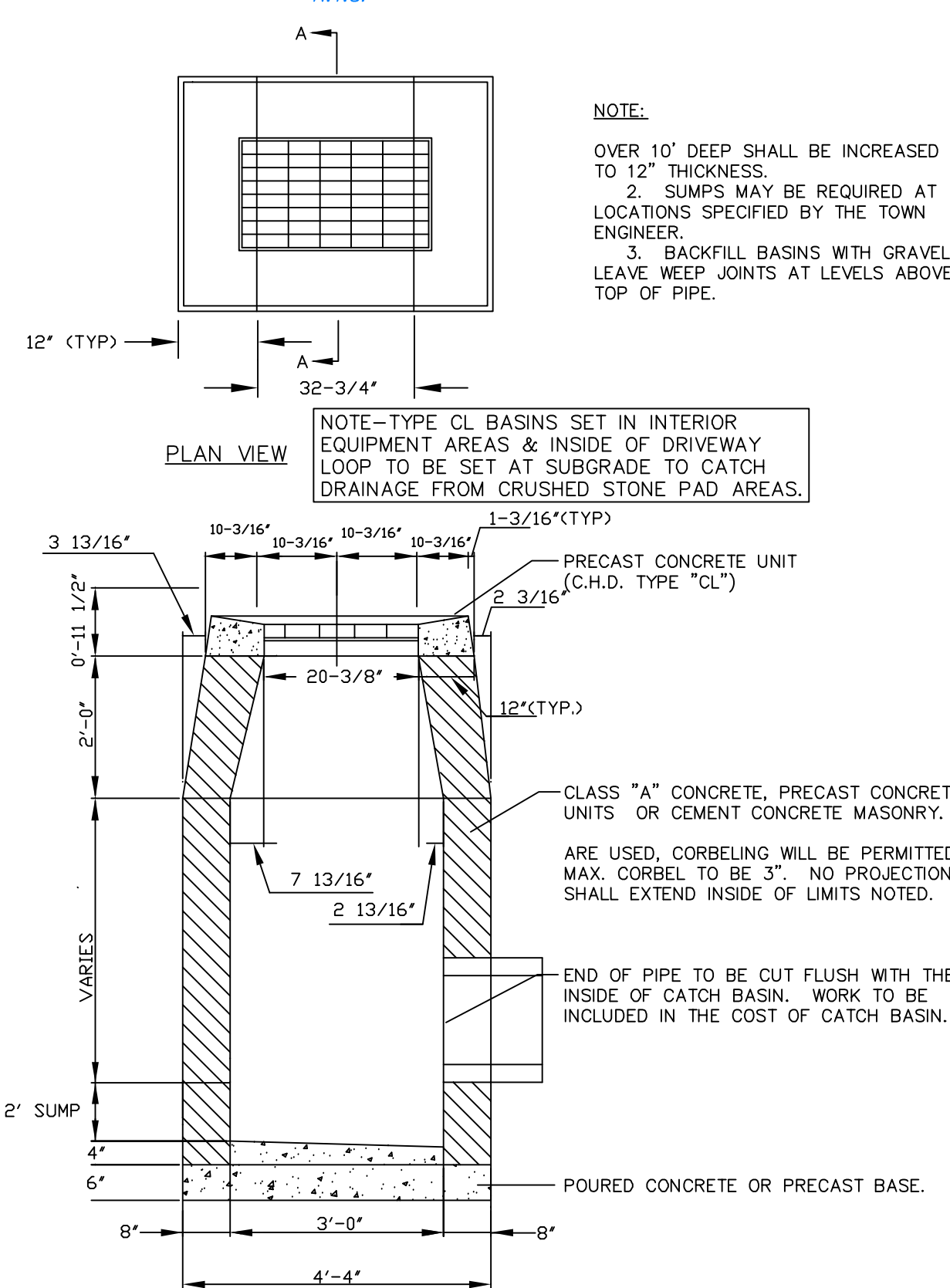

STANDARD TYPE "CL" CATCH BASIN
N.T.S.

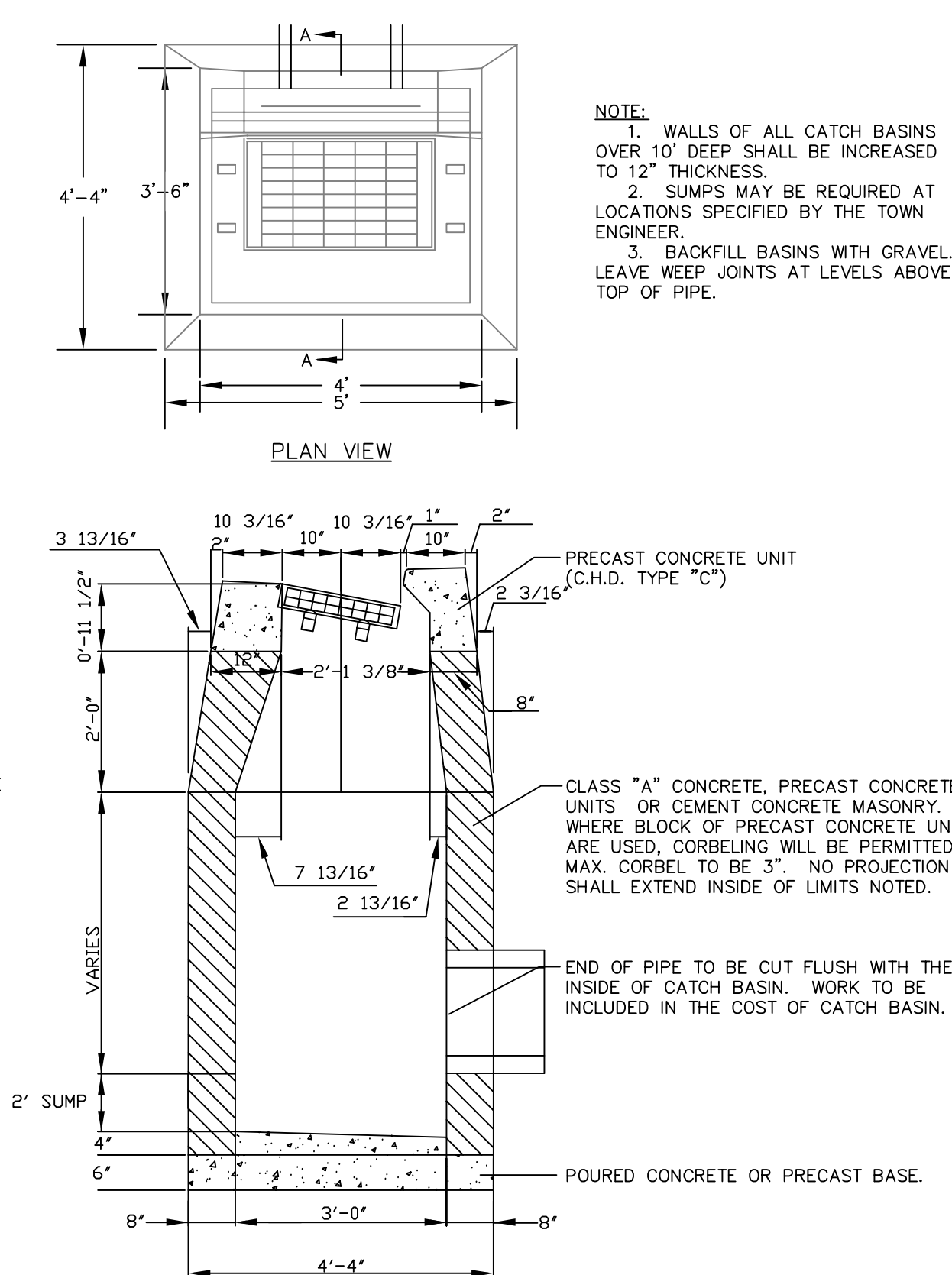

STANDARD TYPE "C" CATCH BASIN
N.T.S.

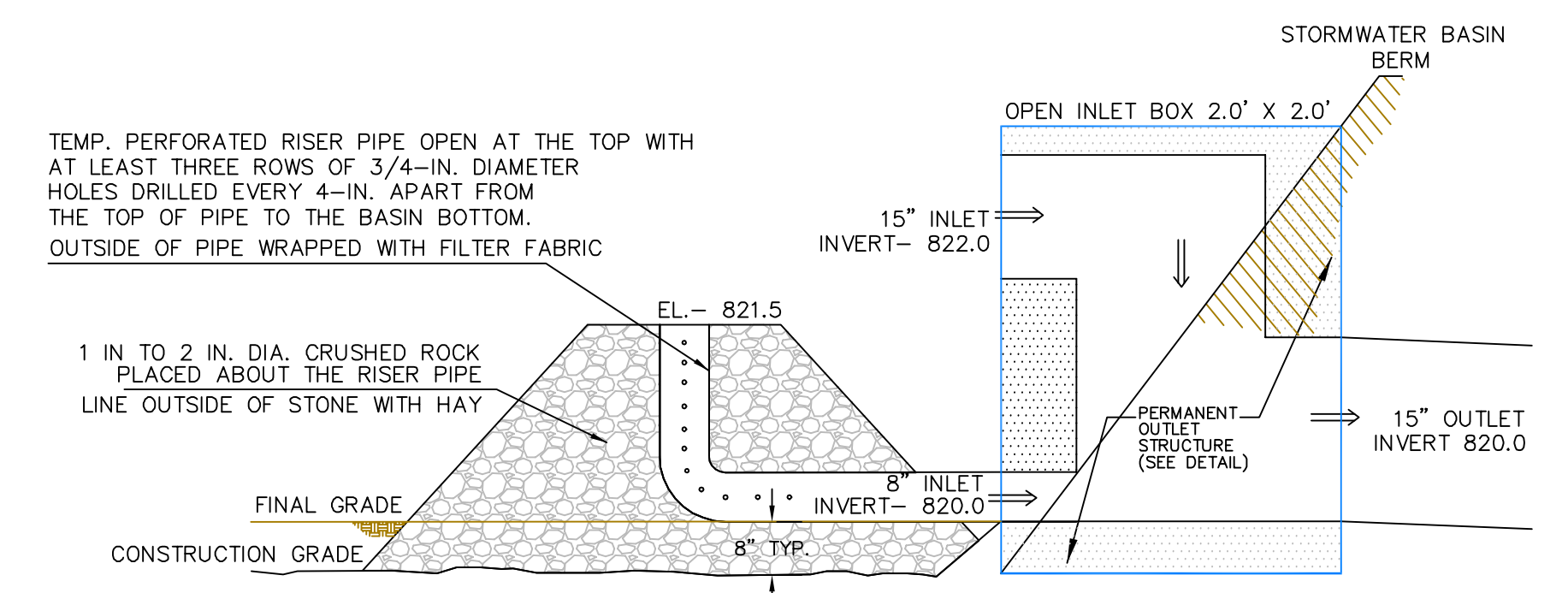

TEMPORARY OUTLET PIPE FOR SEDIMENT CONTAINMENT RENOVATION AREA A
N.T.S.

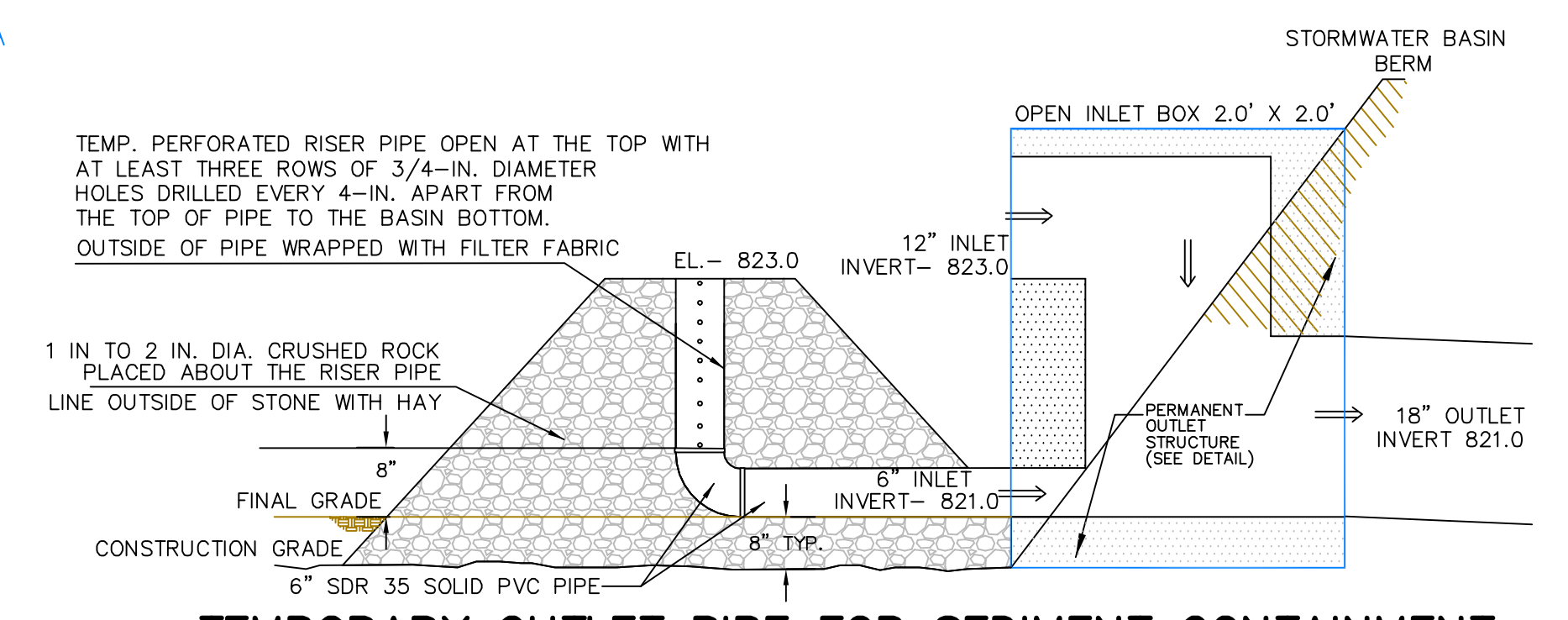

TEMPORARY OUTLET PIPE FOR SEDIMENT CONTAINMENT RENOVATION AREA B
N.T.S.

NO.	REVISION	DATE
1	REV. PER SITING COUNCIL REVIEW	13 FEB 15

Previous Editions Obsolete

STORM DRAINAGE DETAILS

CPV TOWANTIC ENERGY CENTER

WOODBURY CONNECTICUT

CORNERSTONE PROFESSIONAL PARK, SUITE D-101
43 SHERMAN HILL ROAD
(203) 266-0778

CONNECTIONS

DRAWN: BB APPROVED: CJ
SCALE: N.T.S.
DATE: 26 SEP 14
PROJ. NO.: 98132
CADD FILE NAME: 98132
DRAWING NO.: C 321

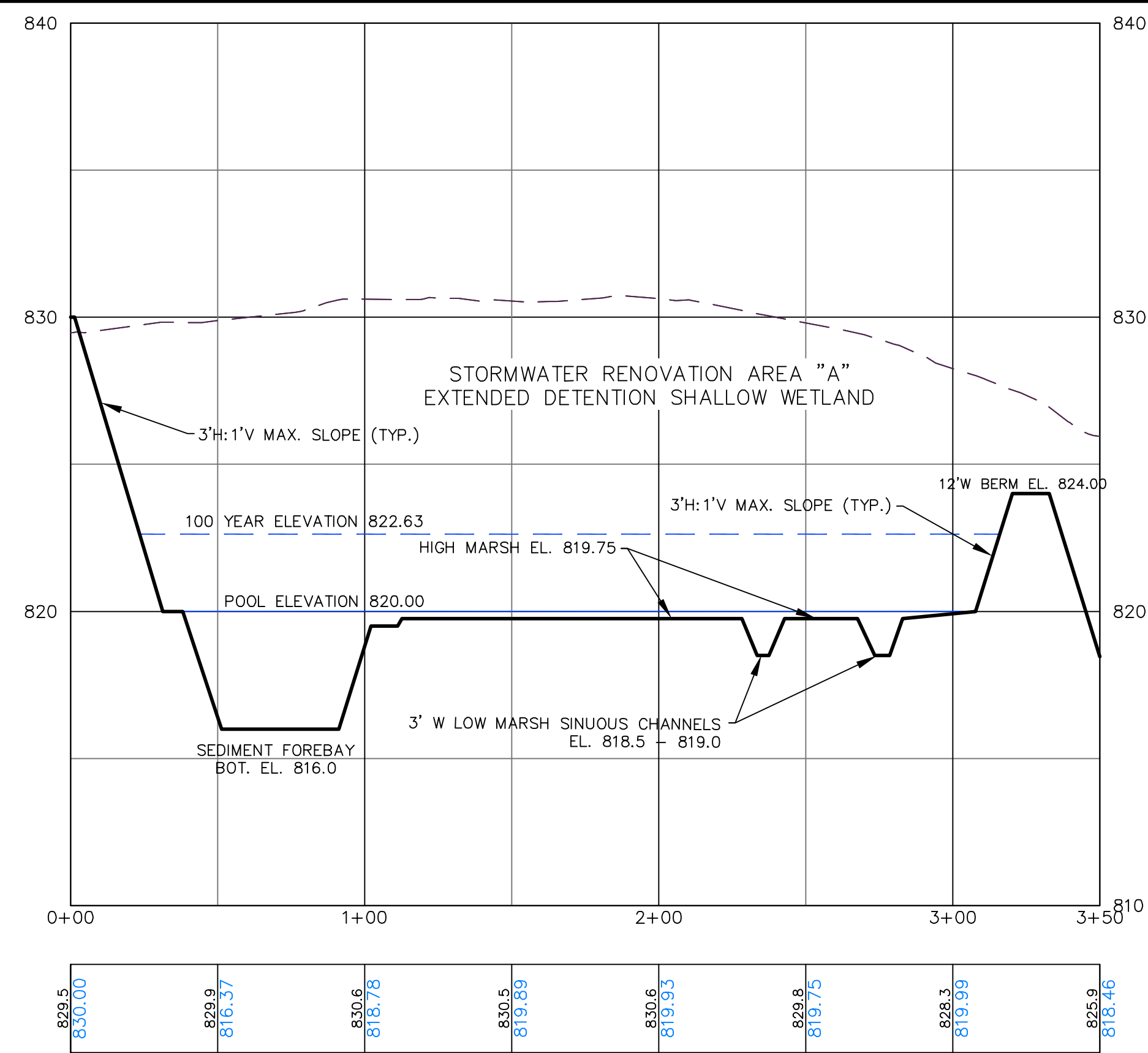

SECTION A-A

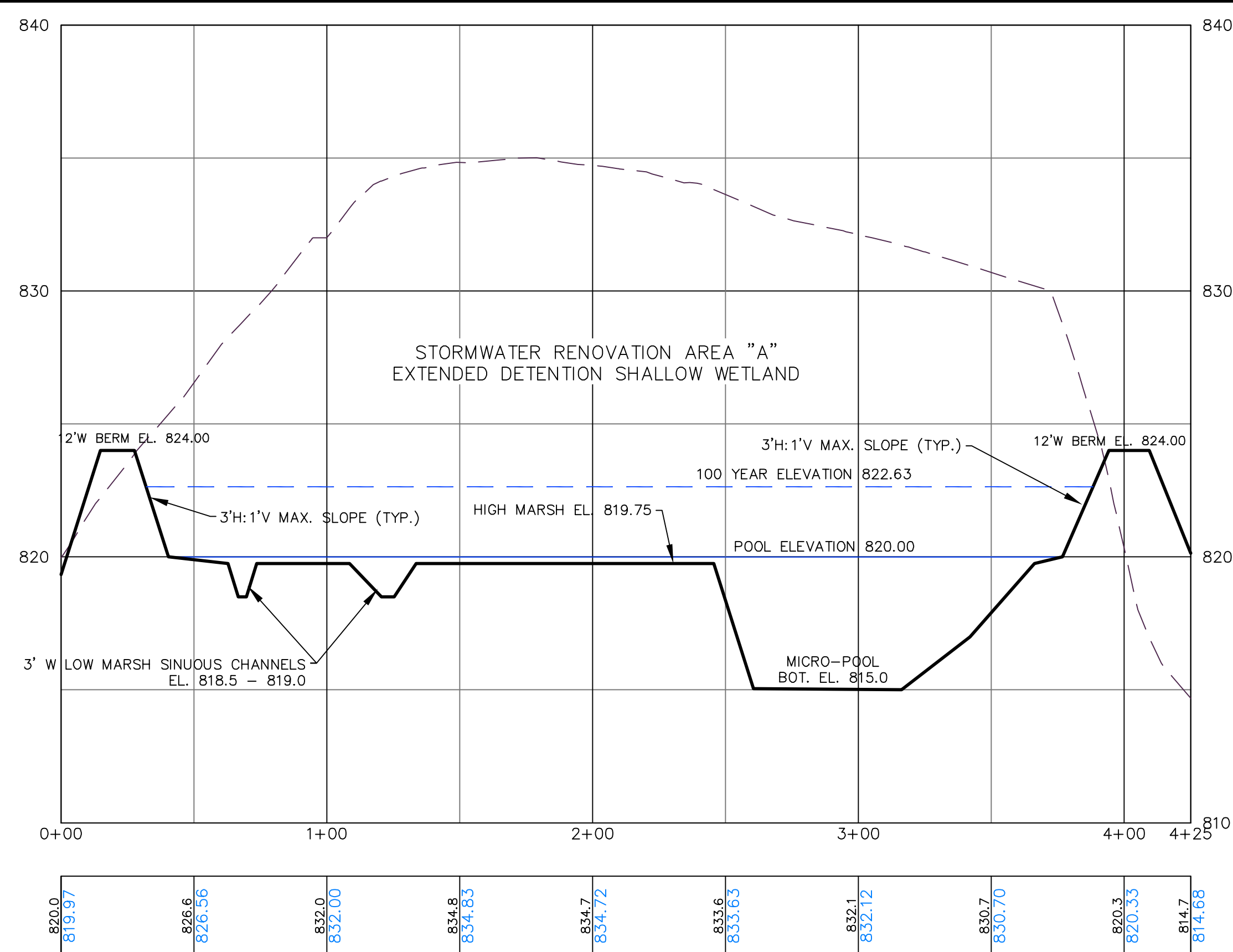

SECTION B-B

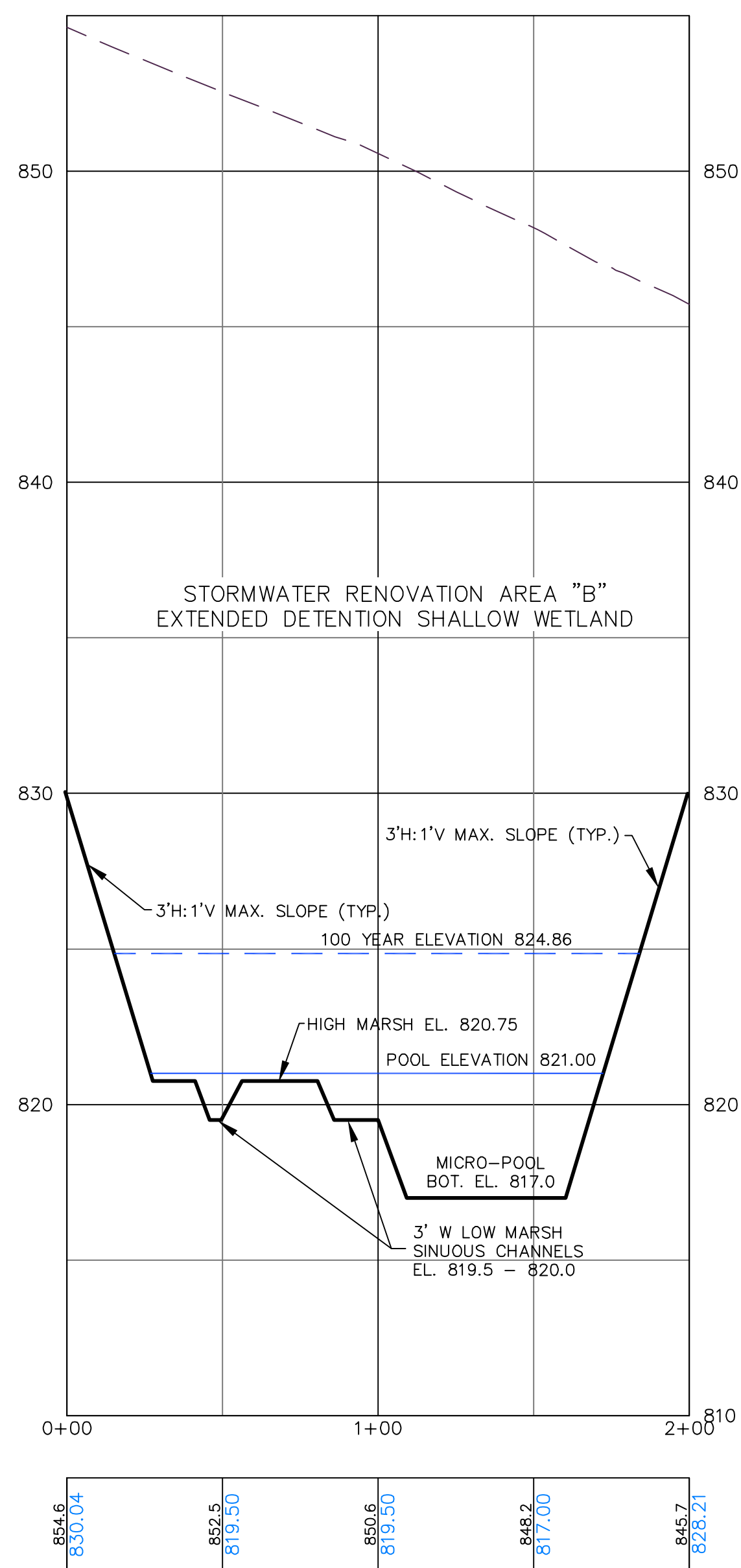

SECTION C-C

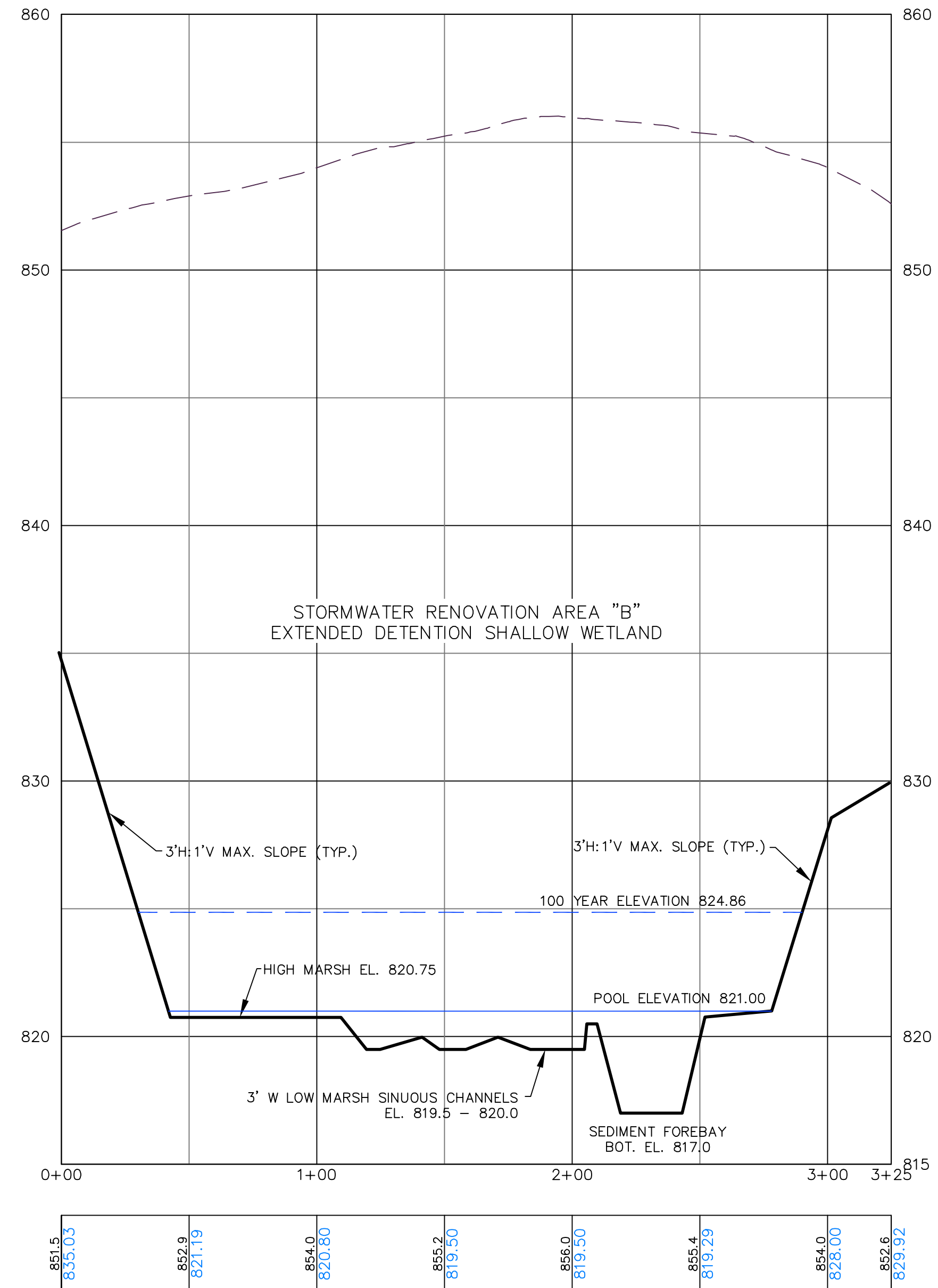

SECTION D-D

PLANTING SCHEDULE FOR EXTENDED DETENTION SHALLOW WETLAND BASIN A

Quantity	Botanical Name	Common Name	Size	Spacing
Low Marsh				
250	Peltandra virginica ²	Arrow Arum	2"plug	2 ft on center
250	Pontederia cordata ²	Pickereelweed	2"plug	2 ft on center
300	Sagittaria latifolia ¹	Northern Arrowhead	2"plug	2 ft on center
300	Schoenoplectus acutus ³	Hardstem Bulrush	2"plug	2 ft on center
High Marsh				
850	Carex comosa	Bearded Sedge	2"plug	2 ft on center
850	Juncus effusus	Soft Rush	2"plug	2 ft on center
850	Panicum virgatum	Switchgrass	2"plug	2 ft on center
850	Schoenoplectus pungens	Three Square Bulrush	2"plug	2 ft on center
Forebay				
75	Peltandra virginica ²	Arrow Arum	2"plug	2 ft on center
75	Pontederia cordata ²	Pickereelweed	2"plug	2 ft on center
75	Sagittaria latifolia ^{1,2}	Northern Arrowhead	2"plug	2 ft on center
75	Schoenoplectus acutus ³	Hardstem Bulrush	2"plug	2 ft on center
Micropool				
100	Peltandra virginica ²	Arrow Arum	2"plug	2 ft on center
100	Pontederia cordata ²	Pickereelweed	2"plug	2 ft on center
100	Sagittaria latifolia ^{1,2}	Northern Arrowhead	2"plug	2 ft on center
100	Schoenoplectus acutus ³	Hardstem Bulrush	2"plug	2 ft on center

- Notes:
1. Don't plant in Fall.
 2. Plant in areas of inundation up to 12" deep.
 3. Plant in areas of inundation up to 36" deep.
 4. Marsh areas and a 5-foot wide shelf around the outer perimeter of the forebay and micropool shall consist of a minimum of 10 inches of topsoil with at least 8 percent organic carbon by weight.

PLANTING SCHEDULE FOR EXTENDED DETENTION SHALLOW WETLAND BASIN B

Quantity	Botanical Name	Common Name	Size	Spacing
Low Marsh				
200	Peltandra virginica ²	Arrow Arum	2"plug	2 ft on center
200	Pontederia cordata ²	Pickereelweed	2"plug	2 ft on center
150	Sagittaria latifolia ¹	Northern Arrowhead	2"plug	2 ft on center
150	Schoenoplectus acutus ³	Hardstem Bulrush	2"plug	2 ft on center
High Marsh				
250	Carex comosa	Bearded Sedge	2"plug	2 ft on center
250	Juncus effusus	Soft Rush	2"plug	2 ft on center
250	Panicum virgatum	Switchgrass	2"plug	2 ft on center
200	Schoenoplectus pungens	Three Square Bulrush	2"plug	2 ft on center
Forebay				
50	Peltandra virginica ²	Arrow Arum	2"plug	2 ft on center
50	Pontederia cordata ²	Pickereelweed	2"plug	2 ft on center
50	Sagittaria latifolia ^{1,2}	Northern Arrowhead	2"plug	2 ft on center
50	Schoenoplectus acutus ³	Hardstem Bulrush	2"plug	2 ft on center
Micropool				
100	Peltandra virginica ²	Arrow Arum	2"plug	2 ft on center
50	Pontederia cordata ²	Pickereelweed	2"plug	2 ft on center
50	Sagittaria latifolia ^{1,2}	Northern Arrowhead	2"plug	2 ft on center
50	Schoenoplectus acutus ³	Hardstem Bulrush	2"plug	2 ft on center

- Notes:
1. Don't plant in Fall.
 2. Plant in areas of inundation up to 12" deep.
 3. Plant in areas of inundation up to 36" deep.
 4. Marsh areas and a 5-foot wide shelf around the outer perimeter of the forebay and micropool shall consist of a minimum of 10 inches of topsoil with at least 8 percent organic carbon by weight.

NO.	REVISION	DATE
1	REV. PER SITING COUNCIL REVIEW	13 FEB 15
2	REV. PER CT DEEP REVIEW	24 FEB 15

Previous Editions Obsolete

STORMWATER RENOVATION AREA CROSS SECTIONS & PLANTING SCHEDULES

CPV TOWANTIC ENERGY CENTER

OXFORD CONNECTICUT

CIVIL C1

CORNERSTONE PROFESSIONAL PARK, SUITE D-101
43 SHERMAN HILL ROAD
WOODBURY CONNECTICUT (203) 266-0778

PROFESSIONAL ENGINEER
NO. 17206
LICENSED

DATE: 26 SEP 14
PROJECT NO.: 98132
DRAWING NO.: C 325

11 10 9 8 7 6 5 4 3 2 1

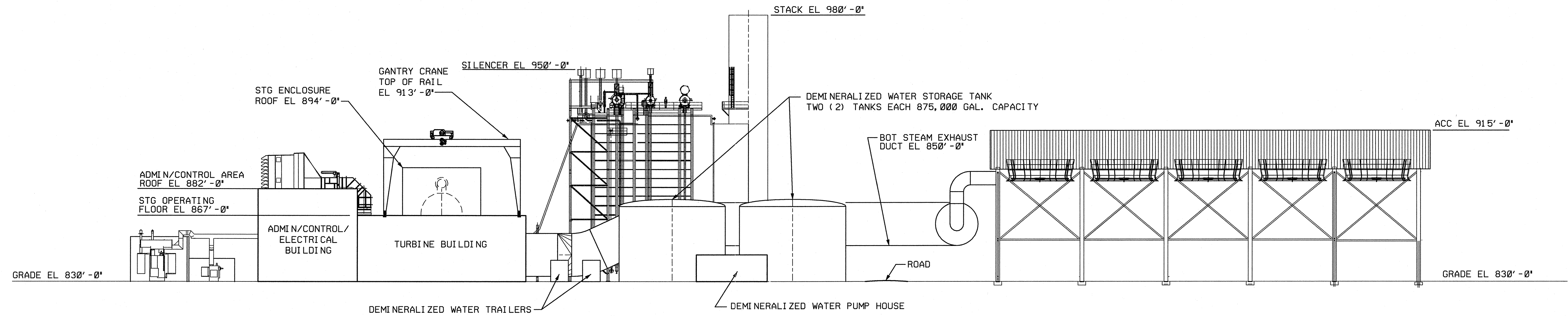

ELEVATION LOOKING EAST
M202

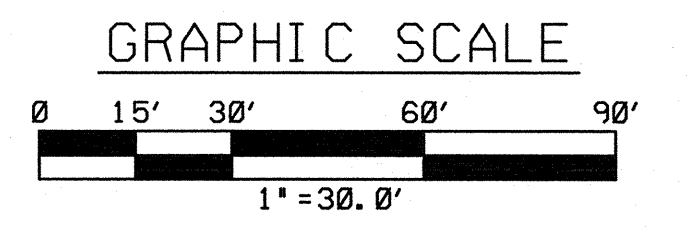

M301.DGN 11:12 08-SEP-2014

Rev No	Revision	Date	Dwn	Chkd	Approved Chief Engr	Rev No	Revision	Date	Dwn	Chkd	Approved Chief Engr	Rev No	Revision	Date	Dwn	Chkd	Approved Chief Engr	Drawing Control		Engineering Review			CPV TOWANTIC ENERGY CENTER OXFORD, CONNECTICUT												
																			Purpose	Approved By	Date	Released By	Date	Disc	Engr	Date	GENERAL ARRANGEMENT ELEVATION LOOKING EAST		BURNS AND ROE ENTERPRISES, INC. Engineers and Constructors - Oradell, NJ Connecticut License No. PEC 39						
																			For Information	P/24	9/8/14	JDM	9/8/14						Lead Engineer	Date	Approved for Construction	Work Order	Drawing No	Sh	Rev
																			For Comment										Chief MECHANICAL Engineer	3328		M301		B	
																			For Bid																
																			For Fabrication																
																			For Construction																

STORMWATER MANAGEMENT AND EROSION CONTROL REPORT

**CPV TOWANTIC ENERGY CENTER
OXFORD, CONNECTICUT**

Prepared by:

CIVIL 1
43 Sherman Hill Road
Suite D-101
Woodbury, CT 06798



September 29, 2014
Revised February 24, 2015

TABLE OF CONTENTS

Introduction	1
Existing Site Conditions	1
Proposed Site Conditions	2
Hydrology	2
Stormwater Management & LID Measures	4
Erosion & Sedimentation Controls	5
Conclusion	6

Appendix A – Drainage Area Maps

Appendix B – Existing Conditions HydroCAD Routing

Appendix C – Proposed Conditions HydroCAD Routing

Appendix D – Rational Method Pipe Sizing

Appendix E – Outlet Protection Calculations

Appendix F – Water Quality Volume Calculations

Appendix G – Water Quality Swale Analysis

Appendix H – Temporary Sediment Trap Sizing

**Appendix I – CT DEEP General Permit for the Discharge of Stormwater
and Dewatering Wastewaters from Construction Activities**

Appendix J - Site Development Plans

Introduction

The project site is located on the northeast side of Woodruff Hill Road near its northerly terminus. The property lies within the Industrial District and consists of 26.2 acres. The current proposal is to construct a gas-fired, electric power plant with associated driveways, parking areas, storm drainage, power plant equipment areas and switchyard.

A study of the site hydrology has been performed to evaluate and mitigate the potential impacts of the proposed power plant and to design a Stormwater Management Plan and an Erosion & Sediment Control Plan in accordance with the 2002 CT E&S Guidelines and the 2004 Stormwater Quality Manual. In order to evaluate the stormwater management requirement for the proposed development, the existing watershed area was delineated based on the current site conditions and analyzed at seven key points down gradient of the property. The total combined watershed area delineated is approximately 35.7 acres which includes 9.2 acres of off-site watershed. This information was used to determine the peak flow rates under both existing and proposed conditions. Appendix A of this report includes a Drainage Area Map which delineates the seven existing and proposed drainage areas.

Existing Site Conditions

Currently, the site consists mostly of woodlands while the western half is all fields. The property is bordered to the east and south by the Algonquin Gas Transmission Facility (Lot 9 of the Woodruff Hill Industrial Park Subdivision), to the west by Woodruff Hill Road and Lots 6, 7 and 8 of the Woodruff Hill Industrial Park Subdivision and to the north by Open Space of the Woodruff Hill Industrial Park Subdivision.

There are four wetlands areas located on or immediately adjacent to the property which were flagged by All-Points Technology Corporation in July of 2014. The wetlands areas are shown on Sheet C310 of the plan set entitled CPV Towantic Energy Center. There are no 100 year flood plains located on the site as defined by FEMA Flood Insurance Rate Mapping.

The project site is located within the Little River Watershed Drainage Basin Number 6920. This watershed is located within the Naugatuck Regional Basin within the Housatonic Major Basin, identified on the Connecticut Department of Environmental Protection Atlas of Public Water Supply Sources and Drainage Basins.

Proposed Site Conditions

The current proposal is to construct a gas-fired power plant with associated switchyard, power plant equipment areas, parking areas and related storage facilities. Approximately 3,000 linear feet access driveway will be constructed to access the facility along with the associated storm drainage system and stormwater quality measures. Of the 26.2 acre site, approximately 22.1 acres will be disturbed during construction, leaving 4.1 acres or 15.6% of the site undisturbed. The power plant will be served by municipal water and sewer.

Hydrology

The primary method of predicting the surface water runoff rates utilized in this report is the computer program HydroCAD V10 Stormwater Modeling System. HydroCAD combines the methodology of technical release No. 55 (TR-55) "Urban Hydrology for Small Watersheds" and technical release No. 20 (TR-20) "Project Formulation-Hydrology". Both TR-55 & TR-20 were originally developed by the USDA Soil Conservation Service (SCS). The HydroCAD program forecasts the rate of surface water runoff based upon several factors, including information on land use, vegetation, watershed areas, soil types, time of concentration, rainfall data, storage volumes and hydraulic capacities of structures. The program predicts the amount of runoff as a function of time. Rainfall events with recurrence frequencies of 2, 10, 25, 50 and 100 years were utilized as input data. The National Weather Service developed 4 storm events to simulate rainfall around the country. The Type III rainfall pattern with 24-hour duration is appropriate for use in Connecticut and was utilized in this analysis.

Existing land use for the site was determined from aerial mapping, field survey and USGS Mapping. The types of land use utilized in the analysis include wood, grass, meadow and impervious cover. Soil types in the watershed were determined from the NRCS Web Soil Survey prepared by the United States Department of Agriculture. The existing watershed was found to contain only type C soils, along with impervious areas (Appendix B). The HydroCAD routing analysis was also completed under the proposed conditions in order to compare pre-development and post-development flows for all the proposed design storms (Appendix C).

The proposed storm drainage piping and swale system was designed using the rational method with adequate capacity to convey the 25-year storm event (Appendix D). The overall watershed was subdivided into sub-basins to determine the drainage area and stormwater runoff to each catch basin, pipe and swale. Inlet control capacity as well as velocity was also analyzed at each structure.

Introduction

The project site is located on the northeast side of Woodruff Hill Road near its northerly terminus. The property lies within the Industrial District and consists of 26.2 acres. The current proposal is to construct a gas-fired, electric power plant with associated driveways, parking areas, storm drainage, power plant equipment areas and switchyard.

A study of the site hydrology has been performed to evaluate and mitigate the potential impacts of the proposed power plant and to design a Stormwater Management Plan and an Erosion & Sediment Control Plan in accordance with the 2002 CT E&S Guidelines and the 2004 Stormwater Quality Manual. In order to evaluate the stormwater management requirement for the proposed development, the existing watershed area was delineated based on the current site conditions and analyzed at seven key points down gradient of the property. The total combined watershed area delineated is approximately 35.7 acres which includes 9.2 acres of off-site watershed. This information was used to determine the peak flow rates under both existing and proposed conditions. Appendix A of this report includes a Drainage Area Map which delineates the seven existing and proposed drainage areas.

Existing Site Conditions

Currently, the site consists mostly of woodlands while the western half is all fields. The property is bordered to the east and south by the Algonquin Gas Transmission Facility (Lot 9 of the Woodruff Hill Industrial Park Subdivision), to the west by Woodruff Hill Road and Lots 6, 7 and 8 of the Woodruff Hill Industrial Park Subdivision and to the north by Open Space of the Woodruff Hill Industrial Park Subdivision.

There are four wetlands areas located on or immediately adjacent to the property which were flagged by All-Points Technology Corporation in July of 2014. The wetlands areas are shown on Sheet C310 of the plan set entitled CPV Towantic Energy Center. There are no 100 year flood plains located on the site as defined by FEMA Flood Insurance Rate Mapping.

The project site is located within the Little River Watershed Drainage Basin Number 6920. This watershed is located within the Naugatuck Regional Basin within the Housatonic Major Basin, identified on the Connecticut Department of Environmental Protection Atlas of Public Water Supply Sources and Drainage Basins.

Proposed Site Conditions

The current proposal is to construct a gas-fired power plant with associated switchyard, power plant equipment areas, parking areas and related storage facilities. Approximately 3,000 linear feet access driveway will be constructed to access the facility along with the associated storm drainage system and stormwater quality measures. Of the 26.2 acre site, approximately 22.1 acres will be disturbed during construction, leaving 4.1 acres or 15.6% of the site undisturbed. The power plant will be served by municipal water and sewer.

Hydrology

The primary method of predicting the surface water runoff rates utilized in this report is the computer program HydroCAD V10 Stormwater Modeling System. HydroCAD combines the methodology of technical release No. 55 (TR-55) "Urban Hydrology for Small Watersheds" and technical release No. 20 (TR-20) "Project Formulation-Hydrology". Both TR-55 & TR-20 were originally developed by the USDA Soil Conservation Service (SCS). The HydroCAD program forecasts the rate of surface water runoff based upon several factors, including information on land use, vegetation, watershed areas, soil types, time of concentration, rainfall data, storage volumes and hydraulic capacities of structures. The program predicts the amount of runoff as a function of time. Rainfall events with recurrence frequencies of 2, 10, 25, 50 and 100 years were utilized as input data. The National Weather Service developed 4 storm events to simulate rainfall around the country. The Type III rainfall pattern with 24-hour duration is appropriate for use in Connecticut and was utilized in this analysis.

Existing land use for the site was determined from aerial mapping, field survey and USGS Mapping. The types of land use utilized in the analysis include wood, grass, meadow and impervious cover. Soil types in the watershed were determined from the NRCS Web Soil Survey prepared by the United States Department of Agriculture. The existing watershed was found to contain only type C soils, along with impervious areas (Appendix B). The HydroCAD routing analysis was also completed under the proposed conditions in order to compare pre-development and post-development flows for all the proposed design storms (Appendix C).

The proposed storm drainage piping and swale system was designed using the rational method with adequate capacity to convey the 25-year storm event (Appendix D). The overall watershed was subdivided into sub-basins to determine the drainage area and stormwater runoff to each catch basin, pipe and swale. Inlet control capacity as well as velocity was also analyzed at each structure.

The pre and post development stormwater runoff was analyzed at seven key points down gradient of the site (DP-1, DP-2A, DP-2B, DP-3, DP-4, DP-5 and DP-6). The storm drainage system is designed so that post development stormwater flows will either remain the same or be decreased at all of the design points. Another goal of the storm drainage system design is to ensure that long-term post-development stormwater quality is protected and that there will be no erosion caused by the development. This was done by designing the two stormwater renovation areas as *Stormwater Wetlands* using the recommendations found in the *2004 DEEP Stormwater Quality Manual (SQM)*. More specifically the renovation areas have been designed as *Extended Detention Shallow Wetlands* systems. Appropriate outlet protection has also been designed at all points where the storm drainage system discharges.

Below is a summary of pre-development and post-development flows at the seven design points:

		Storm Interval (DP-1)				
		2yr.	10yr.	25yr.	50yr.	100yr
Existing Flow (cfs)		8.2	19.3	23.6	28.8	34.9
Proposed Flow (cfs)		7.2	17.4	21.7	26.8	32.7
		Storm Interval (DP-2A)				
		2yr.	10yr.	25yr.	50yr.	100yr
Existing Flow (cfs)		1.7	4.0	4.8	5.9	7.2
Proposed Flow (cfs)		1.6	3.8	4.6	5.6	6.8
		Storm Interval (DP-2B)				
		2yr.	10yr.	25yr.	50yr.	100yr
Existing Flow (cfs)		1.8	4.5	5.5	6.8	8.3
Proposed Flow (cfs)		1.5	3.5	4.3	5.3	6.4
		Storm Interval (DP-3)				
		2yr.	10yr.	25yr.	50yr.	100yr
Existing Flow (cfs)		3.0	7.0	8.5	10.3	12.4
Proposed Flow (cfs)		2.0	3.6	4.1	4.6	6.9
		Storm Interval (DP-4)				
		2yr.	10yr.	25yr.	50yr.	100yr
Existing Flow (cfs)		0.9	1.9	2.4	2.8	3.4
Proposed Flow (cfs)		0.4	0.7	0.9	1.0	1.2
		Storm Interval (DP-5)				
		2yr.	10yr.	25yr.	50yr.	100yr
Existing Flow (cfs)		2.2	4.6	5.4	6.5	7.7
Proposed Flow (cfs)		2.3	4.6	5.4	6.4	7.6

	Storm Interval (DP-6)				
	2yr.	10yr.	25yr.	50yr.	100yr
Existing Flow (cfs)	1.7	3.7	4.5	5.4	6.5
Proposed Flow (cfs)	1.9	3.7	4.4	5.3	6.2

Stormwater Management & LID Measures

In addition to mitigating post development stormwater flow rates another goal of the storm drainage system design was to ensure that long-term post-development stormwater quality was protected. This is being accomplished through the creation of two stormwater renovation areas, grass-lined water quality swales and pervious surface treatments.

Both of the storm water renovation areas are designed as stormwater wetlands to hold and renovate the Water Quality Volume (WQV) while attenuating peak rates of stormwater runoff. The WQV is the initial flush of stormwater that contains most of the sediment and pollutants as defined in the CT DEP 2004 Stormwater Quality Manual. The WQV will be retained a forebay, low marsh swales and micro-pools in each renovation area. These will hold stormwater, allow it to cool and be exposed to vegetation for filtration & treatment. This design allows for the maximum water quality treatment of post development stormwater runoff.

The Water Quality Volume calculations are included in Appendix F. For stormwater renovation area A we are providing 169% of the required WQV and for stormwater renovation area B we are providing 151% of the required WQV. These are both well in excess of the requirement providing for superior stormwater treatment.

Where the topography of the site allowed, grass lined water quality swales have been designed. These swales will provide for filtration of stormwater coming off of the proposed access drive prior to discharge into the existing storm drainage system south of the property. It should also be noted that the storm drainage system south of the property contains existing stormwater facilities that will further treat and renovate the stormwater prior to the eventual discharge into the wetlands at the bottom of Woodruff Hill Road.

In the interior of the proposed plant access drive where the equipment pad areas are set the surface treatment will be an 8" layer of pervious crushed stone to grade. The switchyard area to the north gets a similar treatment but is 12" thick and contains larger diameter stones. Stormwater that falls in these areas will be held and will not runoff immediately into the storm drainage system. The water will either infiltrate in smaller storm events or will slowly work its way through the stone towards one of the proposed catch basin inlets for the storm drainage

system in larger events. This pervious surface treatment encompasses approximately 8.7 acres of the 11.7 acre level power plant area (74.4%).

Erosion & Sedimentation Controls

The erosion and sediment control plan calls for the use of the latest erosion and sediment control measures in order to minimize and control disturbance during construction and provide a stable site under finished conditions. These measures include:

- Stabilized construction entrance
- Temporary sediment traps
- Geotextile silt fence
- Staked haybales
- Staked straw wattles/compost filter socks
- Temporary soil stockpile areas
- Haybale filters
- Temporary water diversions
- Temporary seeding of exposed soils
- Stone check dams
- Water bars with straw wattles/compost filter sock traps
- Erosion control blankets

The Erosion and Sediment Control Plan is contained on Sheet C315 of the plan set and all of the pertinent erosion control notes and construction sequencing is included on Sheet C330.

Additionally, proper outlet protection has been designed at all proposed drainage discharge points. The outlet protection structures were designed in accordance with the recommendations on the *2000 ConnDOT Drainage Manual* Chapter 8.7 (Appendix E).

Velocities were also analyzed in all of the proposed water quality swales to ensure that a grass-lined surface treatment would be appropriate to prevent erosion of the underlying soils while treating and conveying stormwater.

Conclusion

The goal of the proposed stormwater management system is to minimize the potential for impacts to down gradient properties due to the proposed development and to utilize Best Management Practices (BMPs) to improve post-development stormwater quality from the site. This is accomplished through the establishment of two stormwater renovation areas, grassed lined swales and outlet protection designed in accordance with the recommendations of the *CT DOT 2000 Drainage Manual*, the *2002 CT DEEP Erosion & Sediment Control Guidelines* and the *2004 CT DEEP Stormwater Quality Manual*.

As such, the stormwater management system as designed will provide for long-term protection of the down gradient wetlands and watercourses in the area.

Appendix A - Drainage Area Map

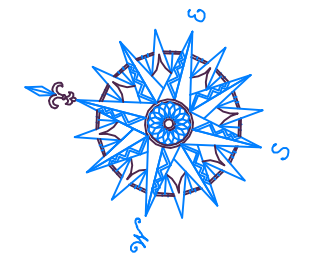
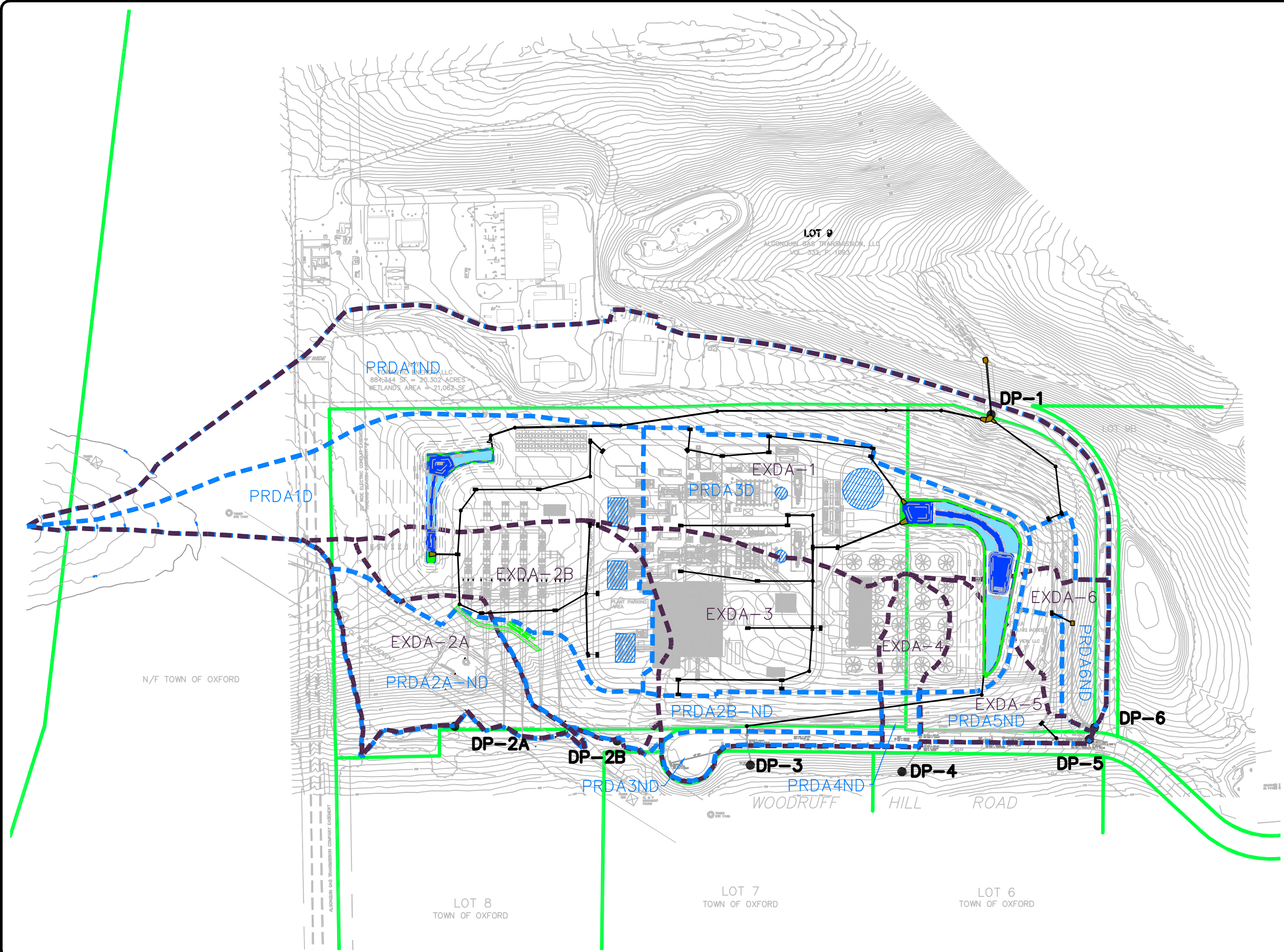

NO.	REVISION	DATE
1	DRAINAGE AREA REVISED	13 FEB 15

Previous Editions Obsolete

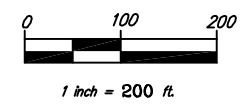

DRAINAGE AREA MAP

CPV TOWANTIC ENERGY CENTER

OXFORD CONNECTICUT



CORNERSTONE PROFESSIONAL PARK, SUITE D-101
43 SHERMAN HILL ROAD
WOODBURY (203) 266-0778 CONNECTICUT

	DRAWN: SC	APPROVED: CJ
	SCALE: 1" = 200'	
	DATE: 26 SEP 14	
	PROJ. NO.: 98132	
	CLIENT FILE NAME: 98132	
	DRAWING NO.: 1 OF 1	

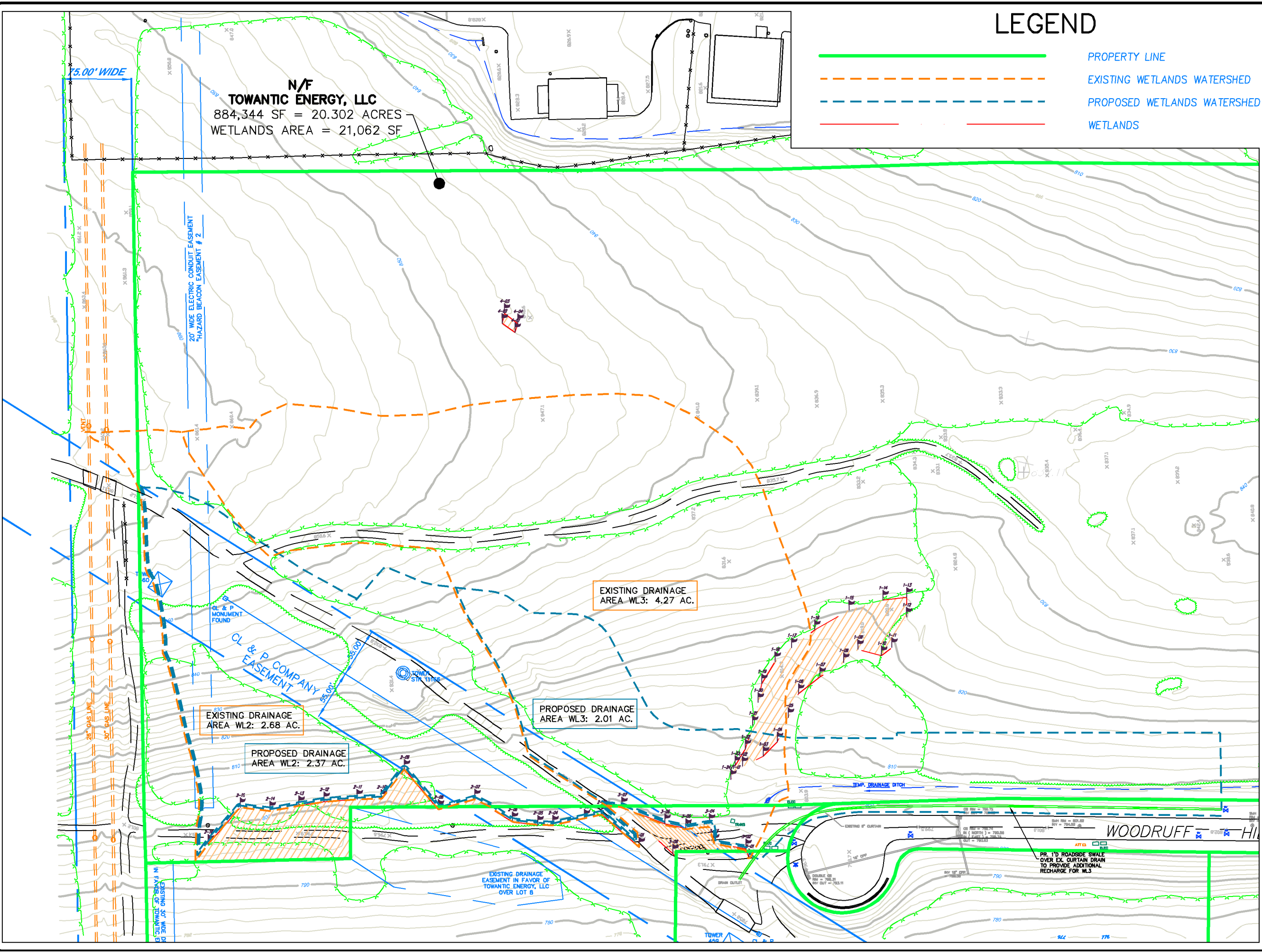

N/F
TOWANTIC ENERGY, LLC
884,344 SF = 20.302 ACRES
WETLANDS AREA = 21,062 SF

LEGEND

- PROPERTY LINE
- EXISTING WETLANDS WATERSHED
- PROPOSED WETLANDS WATERSHED
- WETLANDS

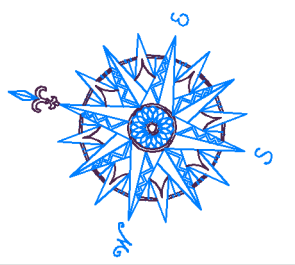

NO.	REVISION	DATE

Previous Editions Obsolete

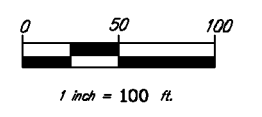

**WETLANDS WATERSHED
DELINEATION
(WETLANDS 2 AND 3)**

**CPV TOWANTIC
ENERGY CENTER**

OXFORD CONNECTICUT



CORNERSTONE PROFESSIONAL PARK, SUITE D-101
43 SHERMAN HILL ROAD
WOODSBURY (203) 266-0778 CONNECTICUT

DRAWN BY: BB APPROVED BY: CJ

SCALE: 1" = 100'

DATE: 12 FEB 15

PROJ. NO.: 98132

CADD FILE NAME: 98132

DRAWING NO.:

Appendix B – Existing Conditions HydroCAD Routing



EXDA-1



DP-1



EXDA-2A



DP-2A



EXDA-2B



DP-2B



EXDA-3

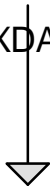

DP-3



EXDA-4



DP-4

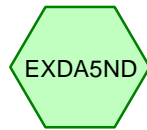

EXDA-5

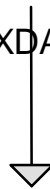

DP-5



EXDA-6

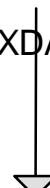

DP-6

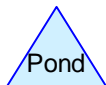
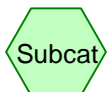

Area Listing (selected nodes)

Area (acres)	CN	Description (subcatchment-numbers)
0.046	98	Impervious (EXDA4ND)
1.755	98	Impervious, HSG C (EXDA1ND, EXDA3ND, EXDA5ND, EXDA6ND)
3.797	71	Meadow, non-grazed, HSG C (EXDA1ND, EXDA3ND, EXDA4ND)
8.518	74	Pasture/grassland/range, Good, HSG C (EXDA1ND, EXDA2AND, EXDA2BND, EXDA3ND, EXDA4ND, EXDA5ND, EXDA6ND)
21.393	70	Woods, Good, HSG C (EXDA1ND, EXDA2AND, EXDA2BND, EXDA3ND)
35.509	72	TOTAL AREA

Soil Listing (selected nodes)

Area (acres)	Soil Group	Subcatchment Numbers
0.000	HSG A	
0.000	HSG B	
35.463	HSG C	EXDA1ND, EXDA2AND, EXDA2BND, EXDA3ND, EXDA4ND, EXDA5ND, EXDA6ND
0.000	HSG D	
0.046	Other	EXDA4ND
35.509		TOTAL AREA

Ground Covers (selected nodes)

HSG-A (acres)	HSG-B (acres)	HSG-C (acres)	HSG-D (acres)	Other (acres)	Total (acres)	Ground Cover	Subcatchment Numbers
0.000	0.000	1.755	0.000	0.046	1.801	Impervious	EXDA1ND, EXDA3ND, EXDA4ND, EXDA5ND, EXDA6ND
0.000	0.000	3.797	0.000	0.000	3.797	Meadow, non-grazed	EXDA1ND, EXDA3ND, EXDA4ND
0.000	0.000	8.518	0.000	0.000	8.518	Pasture/grassland/range, Good	EXDA1ND, EXDA2AND, EXDA2BND, EXDA3ND, EXDA4ND, EXDA5ND, EXDA6ND
0.000	0.000	21.393	0.000	0.000	21.393	Woods, Good	EXDA1ND, EXDA2AND, EXDA2BND, EXDA3ND
0.000	0.000	35.463	0.000	0.046	35.509	TOTAL AREA	

Time span=0.00-24.00 hrs, dt=0.05 hrs, 481 points
 Runoff by SCS TR-20 method, UH=SCS, Weighted-CN
 Reach routing by Stor-Ind+Trans method - Pond routing by Stor-Ind method

Subcatchment EXDA1ND: EXDA-1	Runoff Area=850,940 sf 5.77% Impervious Runoff Depth>0.97" Flow Length=2,225' Tc=61.0 min CN=72 Runoff=8.15 cfs 1.587 af
Subcatchment EXDA2AND: EXDA-2A	Runoff Area=117,366 sf 0.00% Impervious Runoff Depth>0.98" Flow Length=450' Tc=28.5 min CN=72 Runoff=1.68 cfs 0.221 af
Subcatchment EXDA2BND: EXDA-2B	Runoff Area=183,271 sf 0.00% Impervious Runoff Depth>0.87" Flow Length=1,050' Tc=46.7 min CN=70 Runoff=1.79 cfs 0.307 af
Subcatchment EXDA3ND: EXDA-3	Runoff Area=216,972 sf 7.60% Impervious Runoff Depth>1.04" Flow Length=610' Tc=34.5 min CN=73 Runoff=3.04 cfs 0.431 af
Subcatchment EXDA4ND: EXDA-4	Runoff Area=38,901 sf 5.13% Impervious Runoff Depth>1.10" Flow Length=400' Tc=13.0 min CN=74 Runoff=0.87 cfs 0.082 af
Subcatchment EXDA5ND: EXDA-5	Runoff Area=76,831 sf 11.76% Impervious Runoff Depth>1.28" Flow Length=500' Tc=11.3 min CN=77 Runoff=2.15 cfs 0.188 af
Subcatchment EXDA6ND: EXDA-6	Runoff Area=62,500 sf 2.87% Impervious Runoff Depth>1.16" Flow Length=350' Tc=8.3 min CN=75 Runoff=1.69 cfs 0.139 af
Link DP1: DP-1	Inflow=8.15 cfs 1.587 af Primary=8.15 cfs 1.587 af
Link DP2A: DP-2A	Inflow=1.68 cfs 0.221 af Primary=1.68 cfs 0.221 af
Link DP2B: DP-2B	Inflow=1.79 cfs 0.307 af Primary=1.79 cfs 0.307 af
Link DP3: DP-3	Inflow=3.04 cfs 0.431 af Primary=3.04 cfs 0.431 af
Link DP4: DP-4	Inflow=0.87 cfs 0.082 af Primary=0.87 cfs 0.082 af
Link DP5: DP-5	Inflow=2.15 cfs 0.188 af Primary=2.15 cfs 0.188 af
Link DP6: DP-6	Inflow=1.69 cfs 0.139 af Primary=1.69 cfs 0.139 af

Total Runoff Area = 35.509 ac Runoff Volume = 2.954 af Average Runoff Depth = 1.00"
 94.93% Pervious = 33.708 ac 5.07% Impervious = 1.801 ac

Summary for Subcatchment EXDA1ND: EXDA-1

Runoff = 8.15 cfs @ 12.90 hrs, Volume= 1.587 af, Depth> 0.97"

Runoff by SCS TR-20 method, UH=SCS, Weighted-CN, Time Span= 0.00-24.00 hrs, dt= 0.05 hrs
 Type III 24-hr 2-Year Rainfall=3.30"

Area (sf)	CN	Description
635,511	70	Woods, Good, HSG C
148,147	74	Pasture/grassland/range, Good, HSG C
18,170	71	Meadow, non-grazed, HSG C
49,112	98	Impervious, HSG C
850,940	72	Weighted Average
801,828		94.23% Pervious Area
49,112		5.77% Impervious Area

Tc (min)	Length (feet)	Slope (ft/ft)	Velocity (ft/sec)	Capacity (cfs)	Description
37.0	250	0.0320	0.11		Sheet Flow, Woods: Light underbrush n= 0.400 P2= 3.20"
23.0	1,450	0.0440	1.05		Shallow Concentrated Flow, Woodland Kv= 5.0 fps
1.0	525	0.0570	8.87	53.22	Channel Flow, Area= 6.0 sf Perim= 6.0' r= 1.00' n= 0.040 Earth, cobble bottom, clean sides
61.0	2,225	Total			

Subcatchment EXDA1ND: EXDA-1

Hydrograph

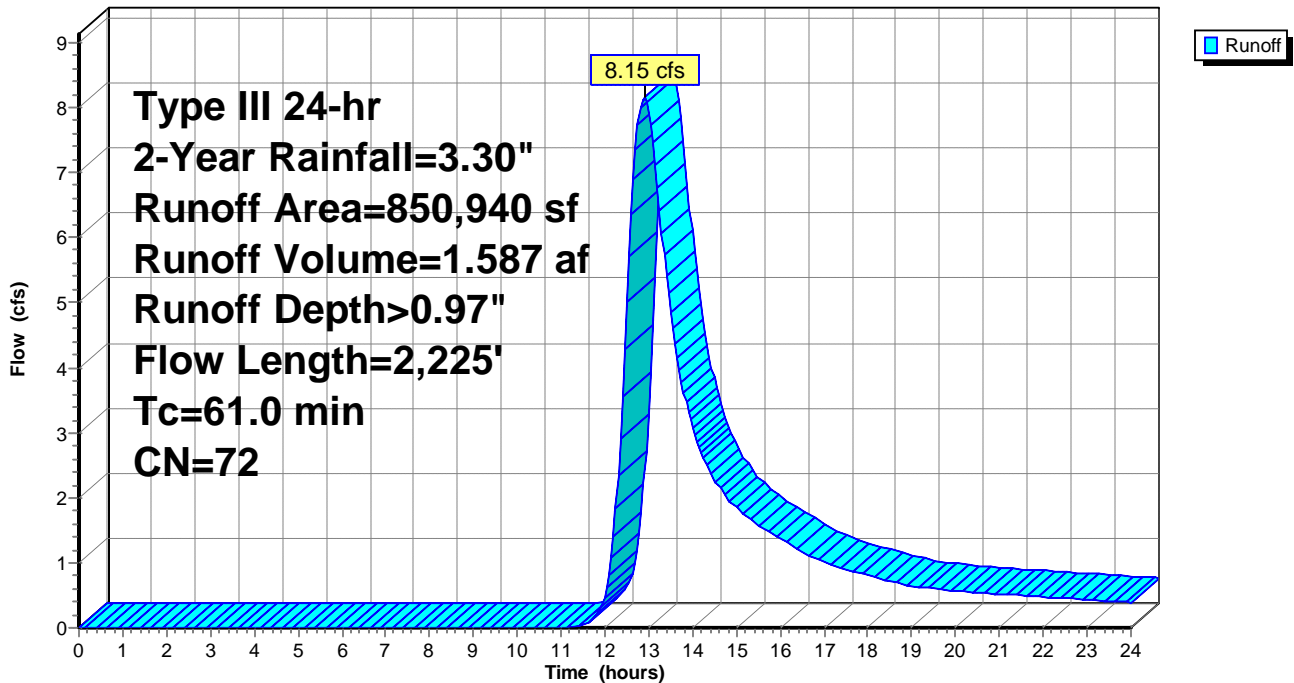

Summary for Subcatchment EXDA2AND: EXDA-2A

Runoff = 1.68 cfs @ 12.44 hrs, Volume= 0.221 af, Depth> 0.98"

Runoff by SCS TR-20 method, UH=SCS, Weighted-CN, Time Span= 0.00-24.00 hrs, dt= 0.05 hrs
 Type III 24-hr 2-Year Rainfall=3.30"

Area (sf)	CN	Description
60,051	70	Woods, Good, HSG C
57,315	74	Pasture/grassland/range, Good, HSG C
117,366	72	Weighted Average
117,366		100.00% Pervious Area

Tc (min)	Length (feet)	Slope (ft/ft)	Velocity (ft/sec)	Capacity (cfs)	Description
27.1	250	0.0700	0.15		Sheet Flow, Woods: Light underbrush n= 0.400 P2= 3.20"
1.4	200	0.2150	2.32		Shallow Concentrated Flow, Woodland Kv= 5.0 fps
28.5	450	Total			

Subcatchment EXDA2AND: EXDA-2A

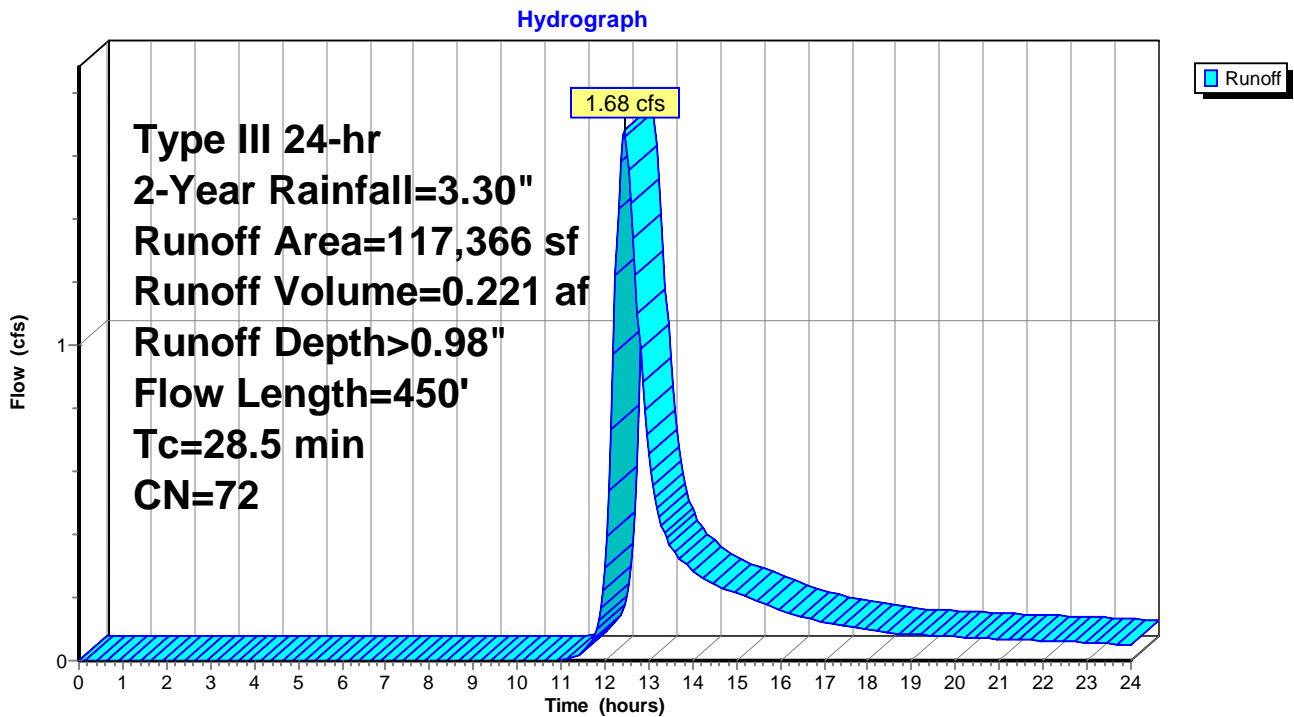

Summary for Subcatchment EXDA2BND: EXDA-2B

Runoff = 1.79 cfs @ 12.71 hrs, Volume= 0.307 af, Depth> 0.87"

Runoff by SCS TR-20 method, UH=SCS, Weighted-CN, Time Span= 0.00-24.00 hrs, dt= 0.05 hrs
 Type III 24-hr 2-Year Rainfall=3.30"

Area (sf)	CN	Description
179,894	70	Woods, Good, HSG C
3,377	74	Pasture/grassland/range, Good, HSG C
183,271	70	Weighted Average
183,271		100.00% Pervious Area

Tc (min)	Length (feet)	Slope (ft/ft)	Velocity (ft/sec)	Capacity (cfs)	Description
36.1	250	0.0340	0.12		Sheet Flow, Woods: Light underbrush n= 0.400 P2= 3.20"
10.6	800	0.0637	1.26		Shallow Concentrated Flow, Woodland Kv= 5.0 fps
46.7	1,050	Total			

Subcatchment EXDA2BND: EXDA-2B

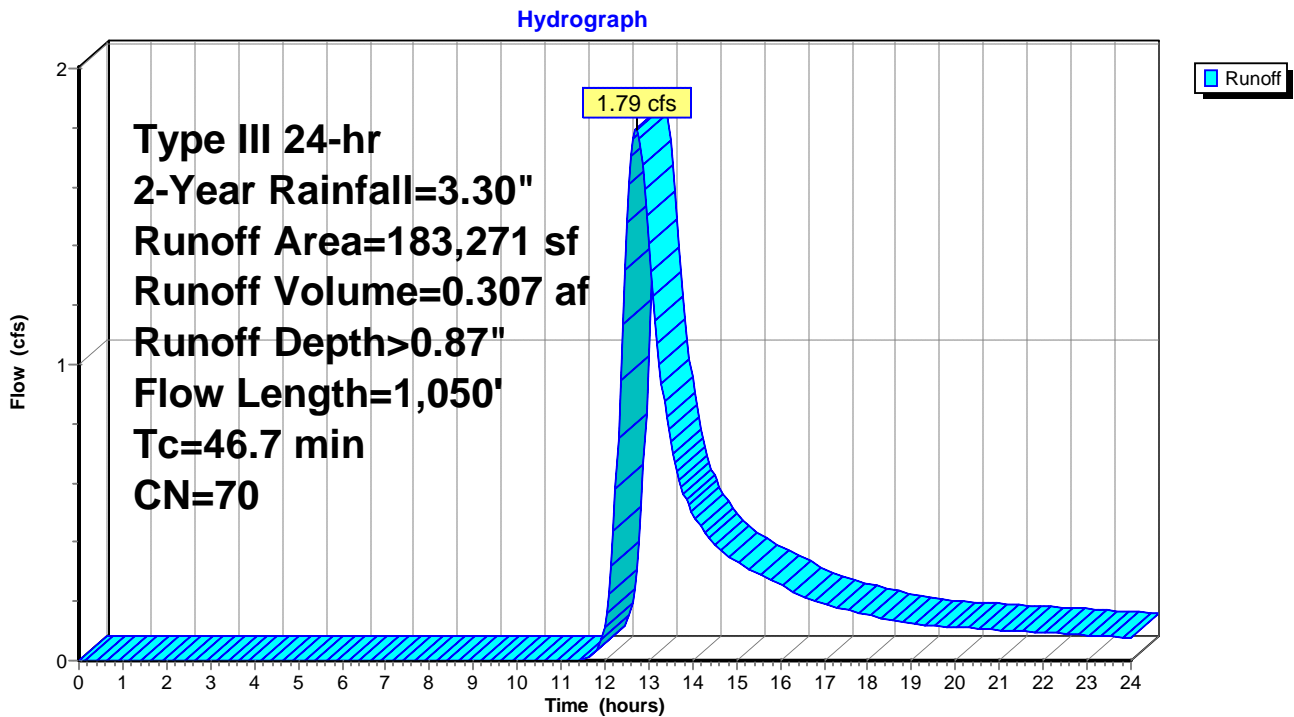

Summary for Subcatchment EXDA3ND: EXDA-3

Runoff = 3.04 cfs @ 12.52 hrs, Volume= 0.431 af, Depth> 1.04"

Runoff by SCS TR-20 method, UH=SCS, Weighted-CN, Time Span= 0.00-24.00 hrs, dt= 0.05 hrs
 Type III 24-hr 2-Year Rainfall=3.30"

Area (sf)	CN	Description
56,418	70	Woods, Good, HSG C
132,061	71	Meadow, non-grazed, HSG C
11,996	74	Pasture/grassland/range, Good, HSG C
16,497	98	Impervious, HSG C
216,972	73	Weighted Average
200,475		92.40% Pervious Area
16,497		7.60% Impervious Area

Tc (min)	Length (feet)	Slope (ft/ft)	Velocity (ft/sec)	Capacity (cfs)	Description
30.5	250	0.0520	0.14		Sheet Flow, Woods: Light underbrush n= 0.400 P2= 3.20"
4.0	360	0.0889	1.49		Shallow Concentrated Flow, Woodland Kv= 5.0 fps

34.5 610 Total

Subcatchment EXDA3ND: EXDA-3

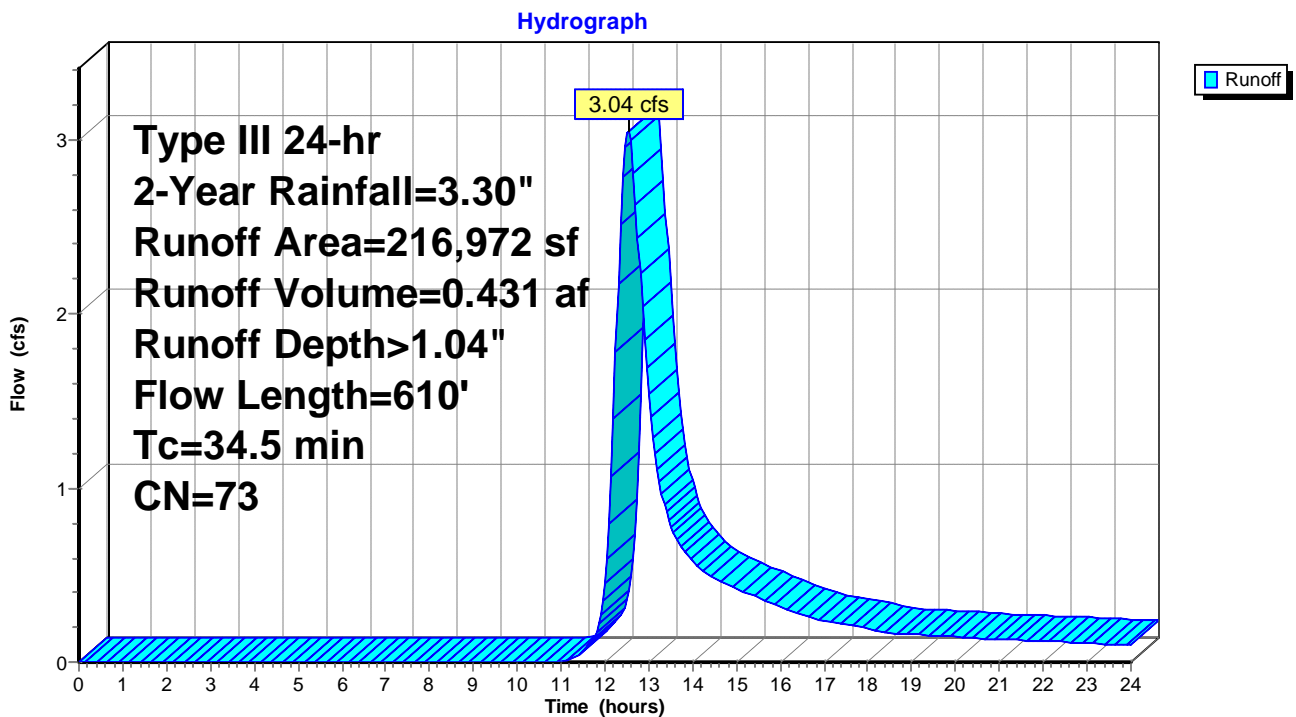

Summary for Subcatchment EXDA4ND: EXDA-4

Runoff = 0.87 cfs @ 12.20 hrs, Volume= 0.082 af, Depth> 1.10"

Runoff by SCS TR-20 method, UH=SCS, Weighted-CN, Time Span= 0.00-24.00 hrs, dt= 0.05 hrs
 Type III 24-hr 2-Year Rainfall=3.30"

Area (sf)	CN	Description
21,726	74	Pasture/grassland/range, Good, HSG C
15,178	71	Meadow, non-grazed, HSG C
* 1,997	98	Impervious
38,901	74	Weighted Average
36,904		94.87% Pervious Area
1,997		5.13% Impervious Area

Tc (min)	Length (feet)	Slope (ft/ft)	Velocity (ft/sec)	Capacity (cfs)	Description
11.8	200	0.0500	0.28		Sheet Flow, Grass: Short n= 0.150 P2= 3.20"
1.2	200	0.1500	2.71		Shallow Concentrated Flow, Short Grass Pasture Kv= 7.0 fps
13.0	400	Total			

Subcatchment EXDA4ND: EXDA-4

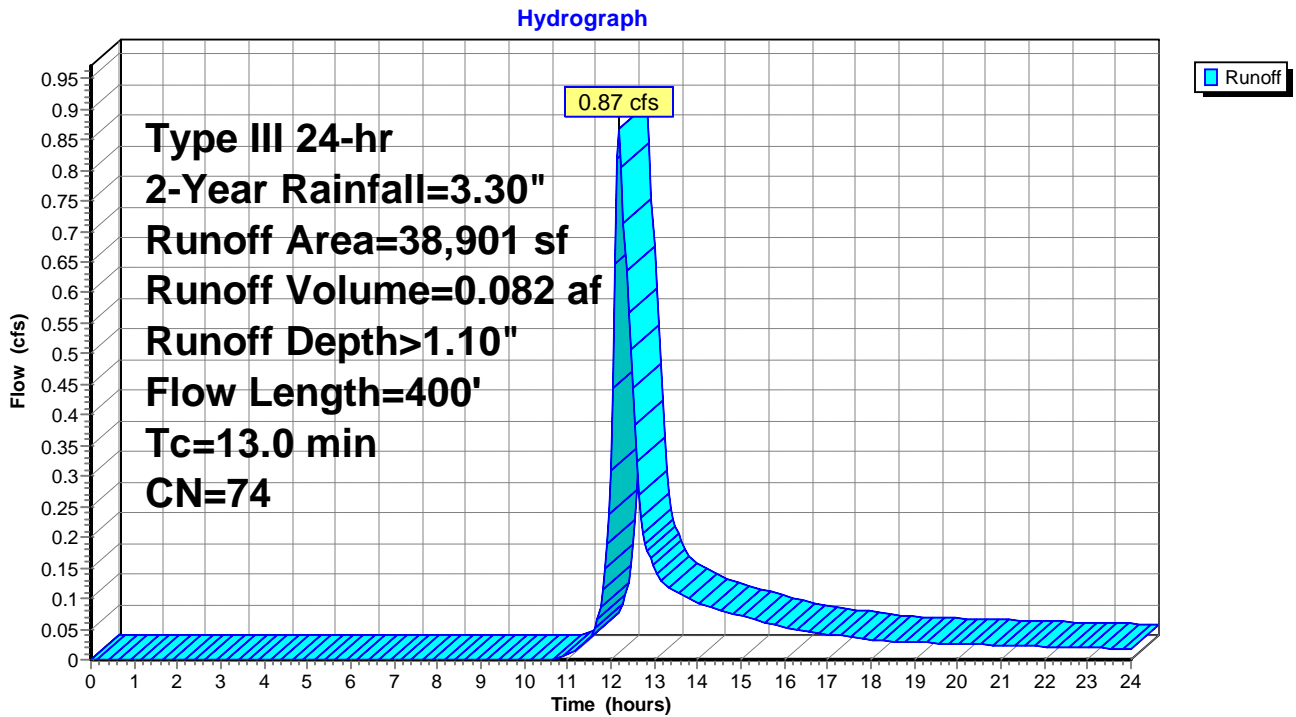

Summary for Subcatchment EXDA5ND: EXDA-5

Runoff = 2.15 cfs @ 12.17 hrs, Volume= 0.188 af, Depth> 1.28"

Runoff by SCS TR-20 method, UH=SCS, Weighted-CN, Time Span= 0.00-24.00 hrs, dt= 0.05 hrs
 Type III 24-hr 2-Year Rainfall=3.30"

Area (sf)	CN	Description
9,039	98	Impervious, HSG C
67,792	74	Pasture/grassland/range, Good, HSG C
76,831	77	Weighted Average
67,792		88.24% Pervious Area
9,039		11.76% Impervious Area

Tc (min)	Length (feet)	Slope (ft/ft)	Velocity (ft/sec)	Capacity (cfs)	Description
10.3	150	0.0400	0.24		Sheet Flow, Grass: Short n= 0.150 P2= 3.20"
1.0	350	0.1350	5.92		Shallow Concentrated Flow, Unpaved Kv= 16.1 fps

11.3 500 Total

Subcatchment EXDA5ND: EXDA-5

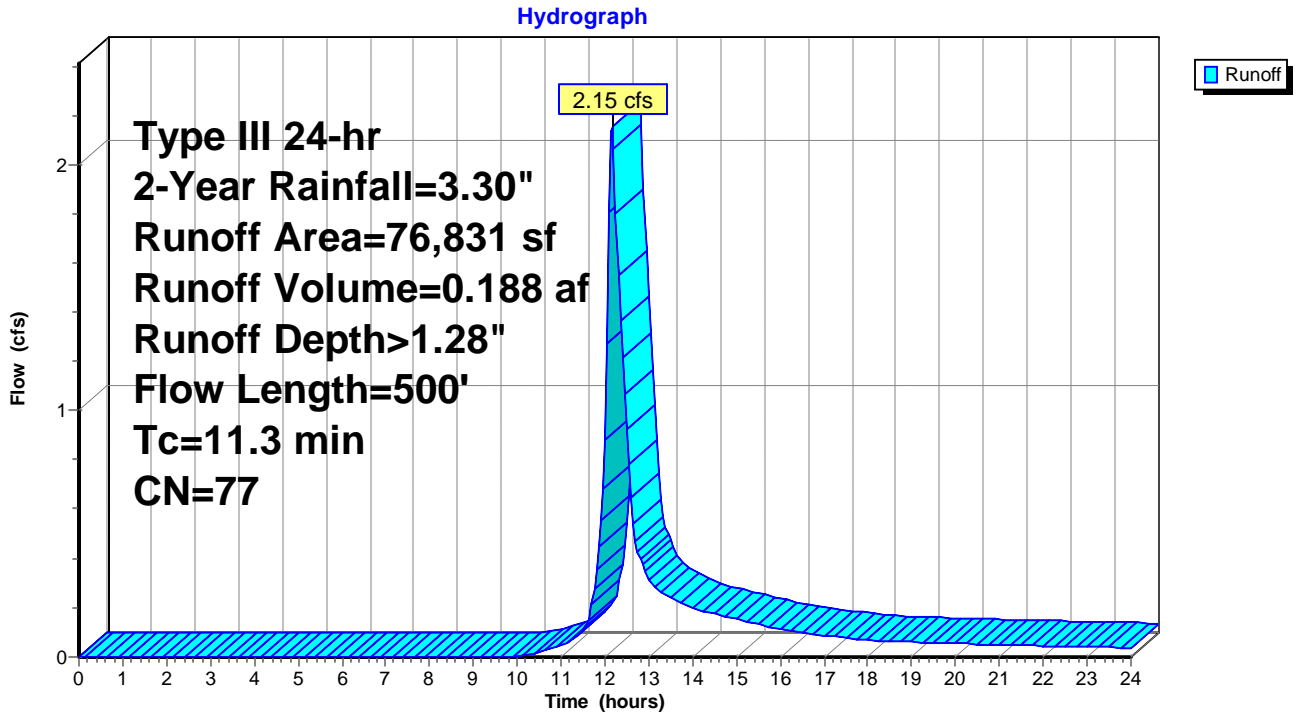

Summary for Subcatchment EXDA6ND: EXDA-6

Runoff = 1.69 cfs @ 12.13 hrs, Volume= 0.139 af, Depth> 1.16"

Runoff by SCS TR-20 method, UH=SCS, Weighted-CN, Time Span= 0.00-24.00 hrs, dt= 0.05 hrs
 Type III 24-hr 2-Year Rainfall=3.30"

Area (sf)	CN	Description
60,704	74	Pasture/grassland/range, Good, HSG C
1,796	98	Impervious, HSG C
62,500	75	Weighted Average
60,704		97.13% Pervious Area
1,796		2.87% Impervious Area

Tc (min)	Length (feet)	Slope (ft/ft)	Velocity (ft/sec)	Capacity (cfs)	Description
7.7	100	0.0360	0.22		Sheet Flow, Grass: Short n= 0.150 P2= 3.20"
0.6	250	0.2050	7.29		Shallow Concentrated Flow, Unpaved Kv= 16.1 fps
8.3	350	Total			

Subcatchment EXDA6ND: EXDA-6

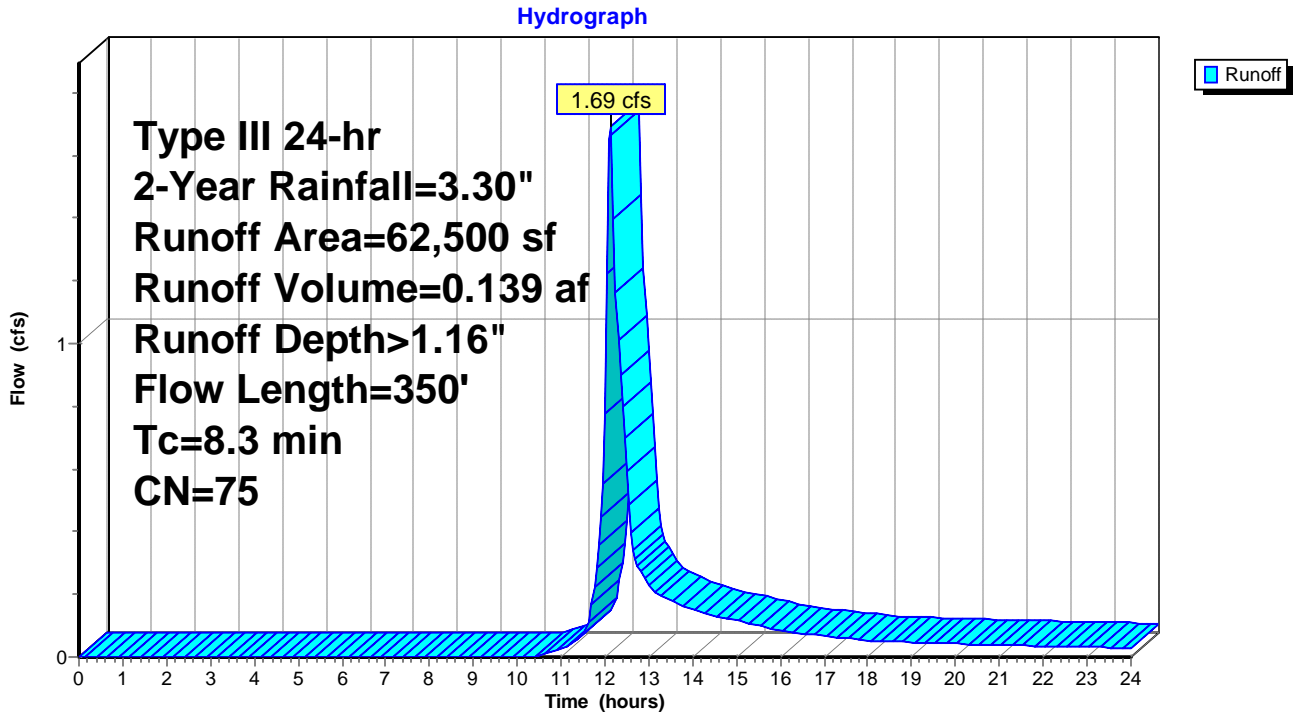

Summary for Link DP1: DP-1

Inflow Area = 19.535 ac, 5.77% Impervious, Inflow Depth > 0.97" for 2-Year event
Inflow = 8.15 cfs @ 12.90 hrs, Volume= 1.587 af
Primary = 8.15 cfs @ 12.90 hrs, Volume= 1.587 af, Atten= 0%, Lag= 0.0 min

Primary outflow = Inflow, Time Span= 0.00-24.00 hrs, dt= 0.05 hrs

Link DP1: DP-1

Hydrograph

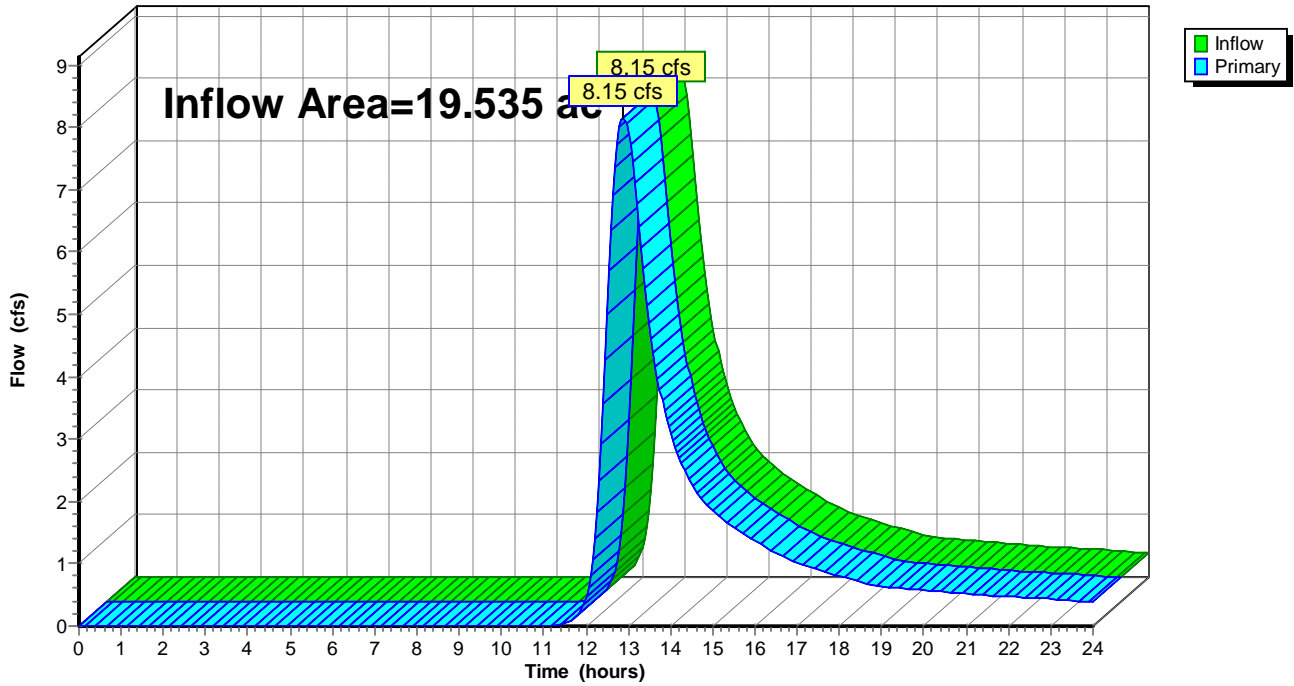

Summary for Link DP2A: DP-2A

Inflow Area = 2.694 ac, 0.00% Impervious, Inflow Depth > 0.98" for 2-Year event
Inflow = 1.68 cfs @ 12.44 hrs, Volume= 0.221 af
Primary = 1.68 cfs @ 12.44 hrs, Volume= 0.221 af, Atten= 0%, Lag= 0.0 min

Primary outflow = Inflow, Time Span= 0.00-24.00 hrs, dt= 0.05 hrs

Link DP2A: DP-2A

Hydrograph

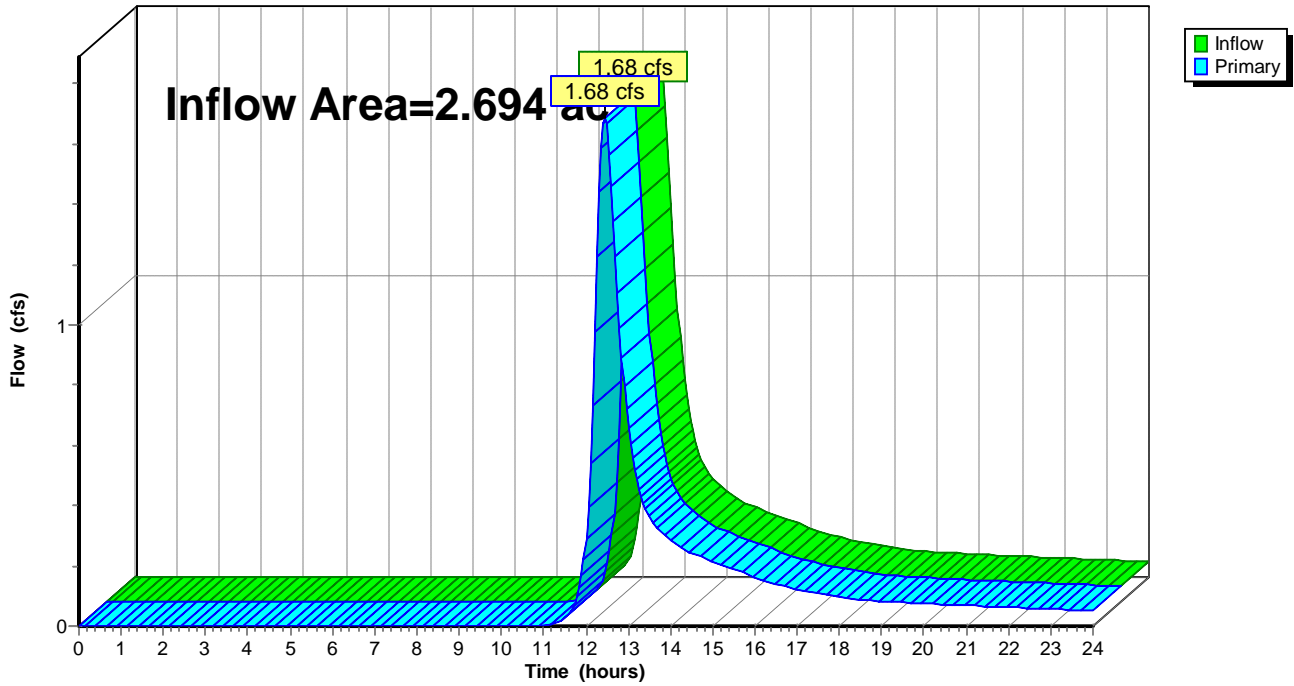

Summary for Link DP2B: DP-2B

Inflow Area = 4.207 ac, 0.00% Impervious, Inflow Depth > 0.87" for 2-Year event
Inflow = 1.79 cfs @ 12.71 hrs, Volume= 0.307 af
Primary = 1.79 cfs @ 12.71 hrs, Volume= 0.307 af, Atten= 0%, Lag= 0.0 min

Primary outflow = Inflow, Time Span= 0.00-24.00 hrs, dt= 0.05 hrs

Link DP2B: DP-2B

Hydrograph

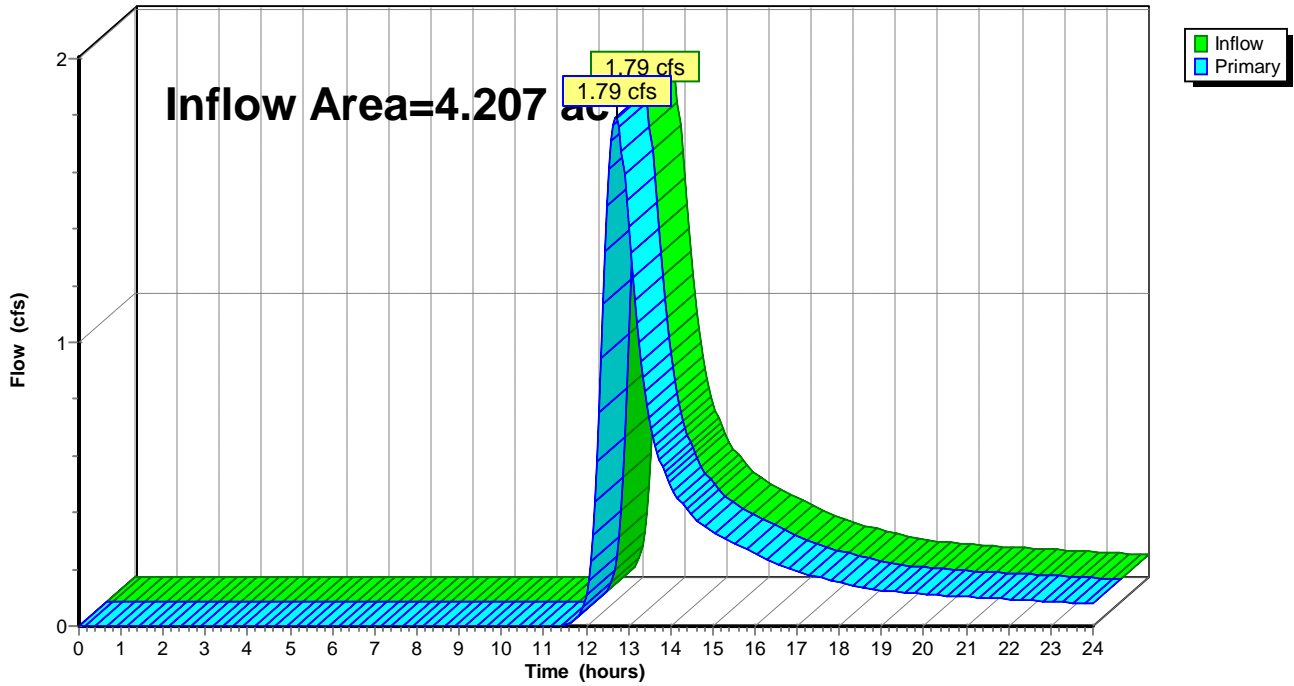

Summary for Link DP3: DP-3

Inflow Area = 4.981 ac, 7.60% Impervious, Inflow Depth > 1.04" for 2-Year event
Inflow = 3.04 cfs @ 12.52 hrs, Volume= 0.431 af
Primary = 3.04 cfs @ 12.52 hrs, Volume= 0.431 af, Atten= 0%, Lag= 0.0 min

Primary outflow = Inflow, Time Span= 0.00-24.00 hrs, dt= 0.05 hrs

Link DP3: DP-3

Hydrograph

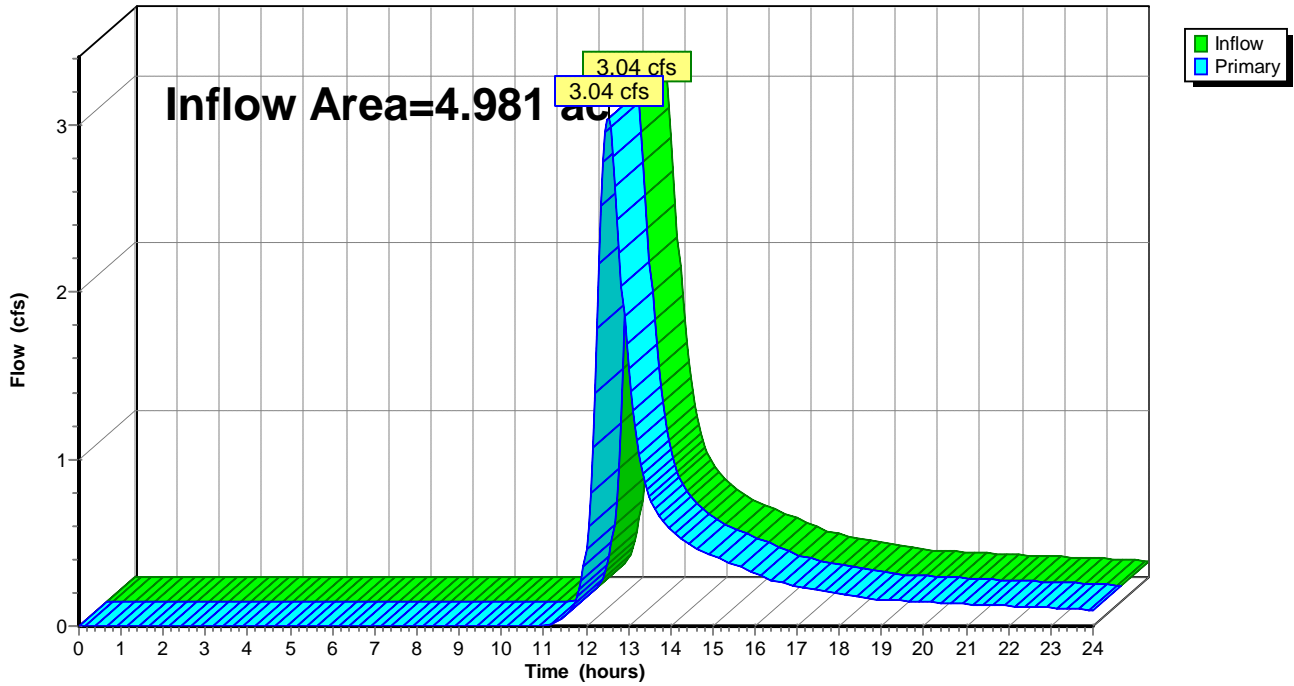

Summary for Link DP4: DP-4

Inflow Area = 0.893 ac, 5.13% Impervious, Inflow Depth > 1.10" for 2-Year event
Inflow = 0.87 cfs @ 12.20 hrs, Volume= 0.082 af
Primary = 0.87 cfs @ 12.20 hrs, Volume= 0.082 af, Atten= 0%, Lag= 0.0 min

Primary outflow = Inflow, Time Span= 0.00-24.00 hrs, dt= 0.05 hrs

Link DP4: DP-4

Hydrograph

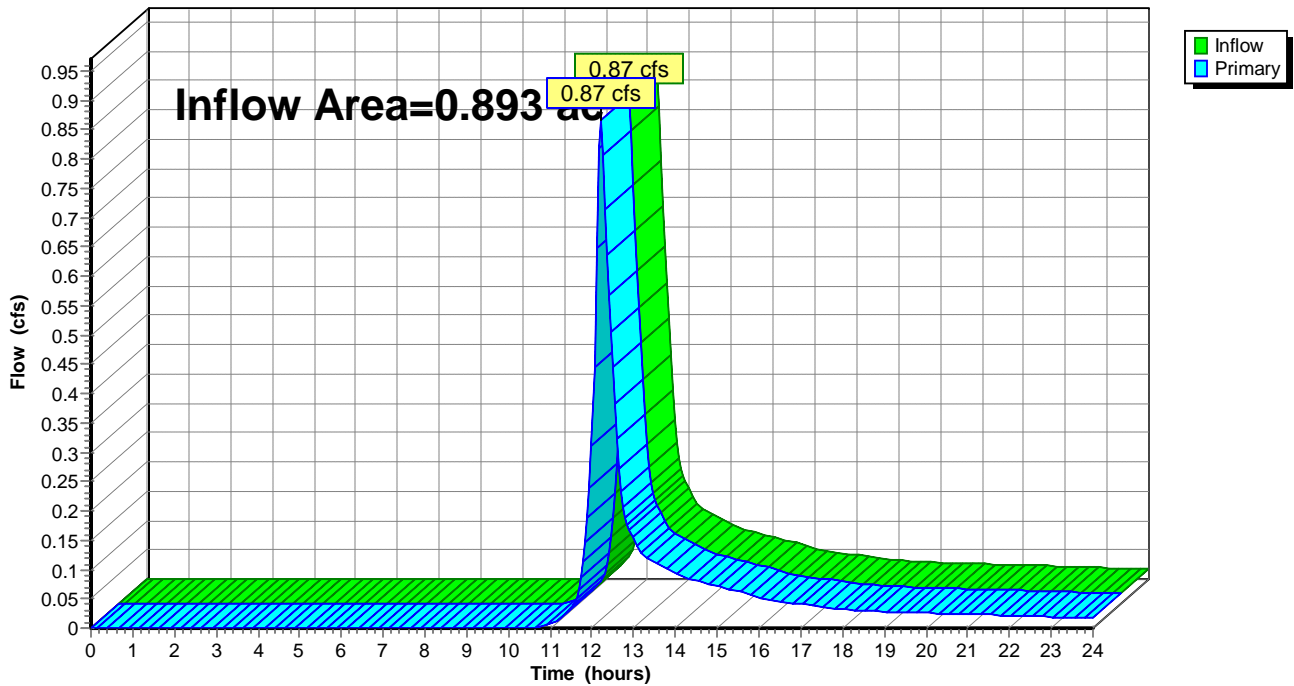

Summary for Link DP5: DP-5

Inflow Area = 1.764 ac, 11.76% Impervious, Inflow Depth > 1.28" for 2-Year event
Inflow = 2.15 cfs @ 12.17 hrs, Volume= 0.188 af
Primary = 2.15 cfs @ 12.17 hrs, Volume= 0.188 af, Atten= 0%, Lag= 0.0 min

Primary outflow = Inflow, Time Span= 0.00-24.00 hrs, dt= 0.05 hrs

Link DP5: DP-5

Hydrograph

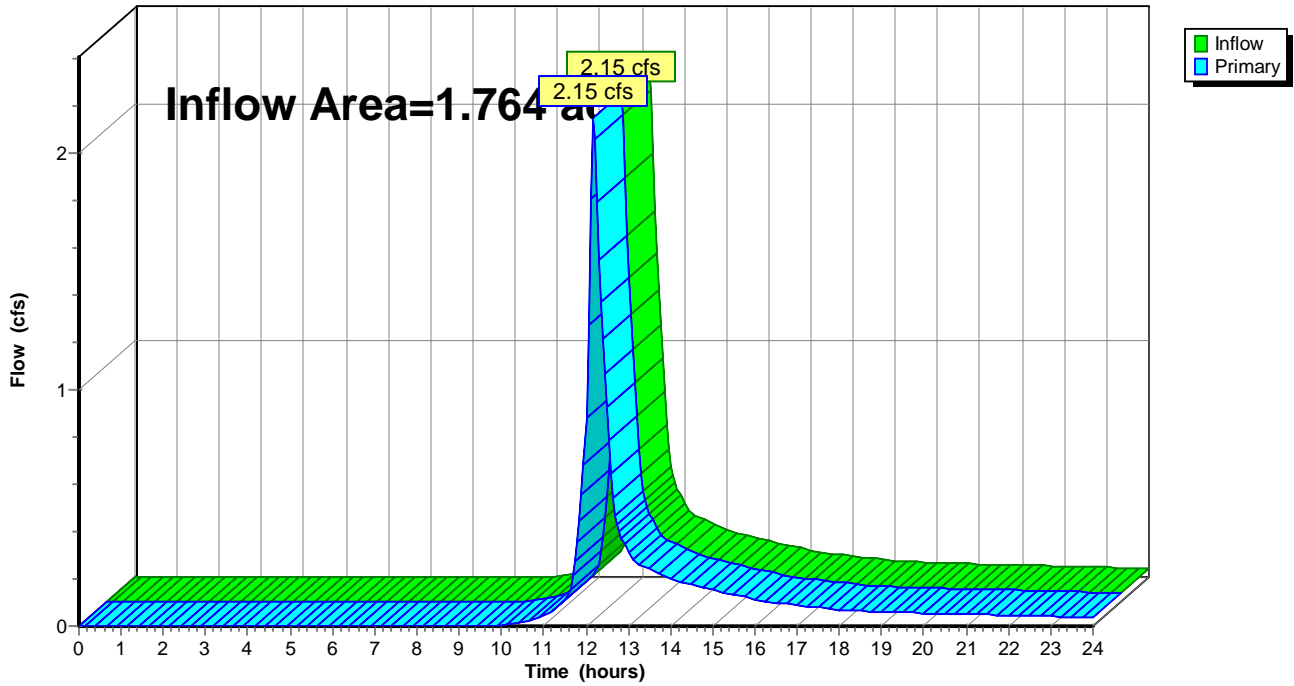

Summary for Link DP6: DP-6

Inflow Area = 1.435 ac, 2.87% Impervious, Inflow Depth > 1.16" for 2-Year event
Inflow = 1.69 cfs @ 12.13 hrs, Volume= 0.139 af
Primary = 1.69 cfs @ 12.13 hrs, Volume= 0.139 af, Atten= 0%, Lag= 0.0 min

Primary outflow = Inflow, Time Span= 0.00-24.00 hrs, dt= 0.05 hrs

Link DP6: DP-6

Hydrograph

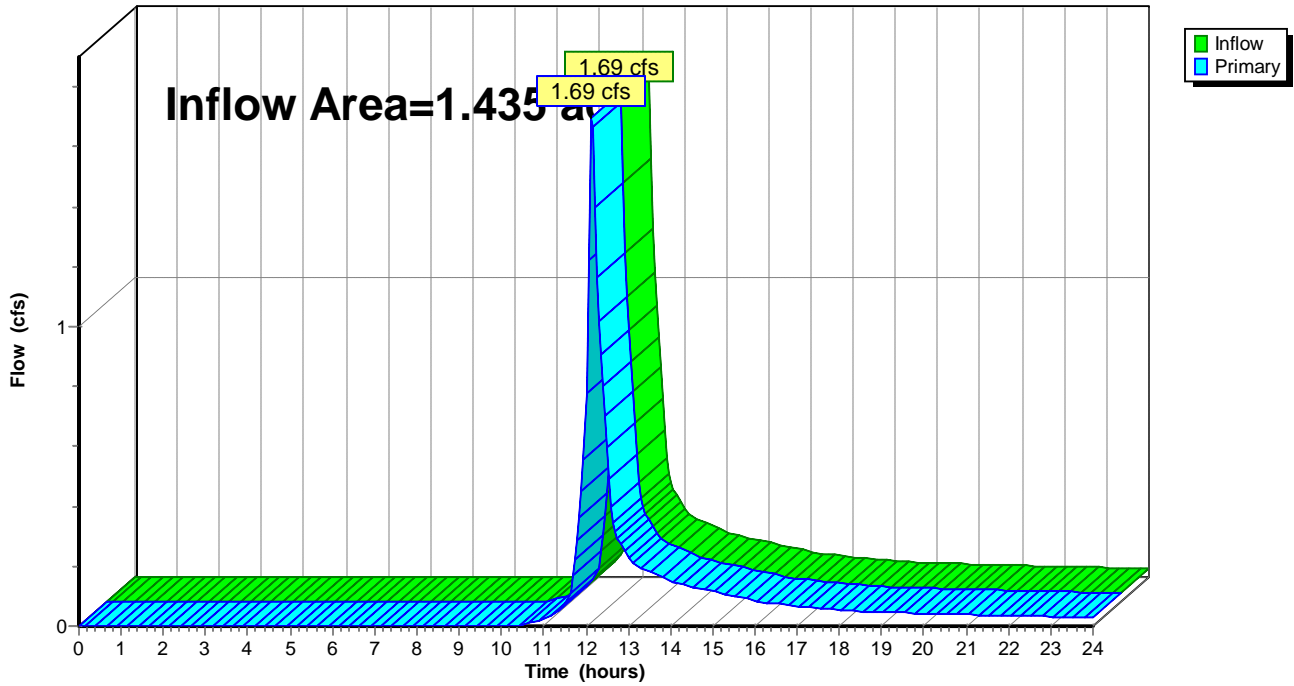

Time span=0.00-24.00 hrs, dt=0.05 hrs, 481 points
 Runoff by SCS TR-20 method, UH=SCS, Weighted-CN
 Reach routing by Stor-Ind+Trans method - Pond routing by Stor-Ind method

Subcatchment EXDA1ND: EXDA-1	Runoff Area=850,940 sf 5.77% Impervious Runoff Depth>2.17" Flow Length=2,225' Tc=61.0 min CN=72 Runoff=19.28 cfs 3.525 af
Subcatchment EXDA2AND: EXDA-2A	Runoff Area=117,366 sf 0.00% Impervious Runoff Depth>2.18" Flow Length=450' Tc=28.5 min CN=72 Runoff=3.96 cfs 0.490 af
Subcatchment EXDA2BND: EXDA-2B	Runoff Area=183,271 sf 0.00% Impervious Runoff Depth>2.01" Flow Length=1,050' Tc=46.7 min CN=70 Runoff=4.45 cfs 0.706 af
Subcatchment EXDA3ND: EXDA-3	Runoff Area=216,972 sf 7.60% Impervious Runoff Depth>2.26" Flow Length=610' Tc=34.5 min CN=73 Runoff=6.97 cfs 0.939 af
Subcatchment EXDA4ND: EXDA-4	Runoff Area=38,901 sf 5.13% Impervious Runoff Depth>2.36" Flow Length=400' Tc=13.0 min CN=74 Runoff=1.94 cfs 0.175 af
Subcatchment EXDA5ND: EXDA-5	Runoff Area=76,831 sf 11.76% Impervious Runoff Depth>2.62" Flow Length=500' Tc=11.3 min CN=77 Runoff=4.52 cfs 0.385 af
Subcatchment EXDA6ND: EXDA-6	Runoff Area=62,500 sf 2.87% Impervious Runoff Depth>2.45" Flow Length=350' Tc=8.3 min CN=75 Runoff=3.74 cfs 0.292 af
Link DP1: DP-1	Inflow=19.28 cfs 3.525 af Primary=19.28 cfs 3.525 af
Link DP2A: DP-2A	Inflow=3.96 cfs 0.490 af Primary=3.96 cfs 0.490 af
Link DP2B: DP-2B	Inflow=4.45 cfs 0.706 af Primary=4.45 cfs 0.706 af
Link DP3: DP-3	Inflow=6.97 cfs 0.939 af Primary=6.97 cfs 0.939 af
Link DP4: DP-4	Inflow=1.94 cfs 0.175 af Primary=1.94 cfs 0.175 af
Link DP5: DP-5	Inflow=4.52 cfs 0.385 af Primary=4.52 cfs 0.385 af
Link DP6: DP-6	Inflow=3.74 cfs 0.292 af Primary=3.74 cfs 0.292 af
<p>Total Runoff Area = 35.509 ac Runoff Volume = 6.514 af Average Runoff Depth = 2.20" 94.93% Pervious = 33.708 ac 5.07% Impervious = 1.801 ac</p>	

Summary for Subcatchment EXDA1ND: EXDA-1

Runoff = 19.28 cfs @ 12.84 hrs, Volume= 3.525 af, Depth> 2.17"

Runoff by SCS TR-20 method, UH=SCS, Weighted-CN, Time Span= 0.00-24.00 hrs, dt= 0.05 hrs
 Type III 24-hr 10-Year Rainfall=5.00"

Area (sf)	CN	Description
635,511	70	Woods, Good, HSG C
148,147	74	Pasture/grassland/range, Good, HSG C
18,170	71	Meadow, non-grazed, HSG C
49,112	98	Impervious, HSG C
850,940	72	Weighted Average
801,828		94.23% Pervious Area
49,112		5.77% Impervious Area

Tc (min)	Length (feet)	Slope (ft/ft)	Velocity (ft/sec)	Capacity (cfs)	Description
37.0	250	0.0320	0.11		Sheet Flow, Woods: Light underbrush n= 0.400 P2= 3.20"
23.0	1,450	0.0440	1.05		Shallow Concentrated Flow, Woodland Kv= 5.0 fps
1.0	525	0.0570	8.87	53.22	Channel Flow, Area= 6.0 sf Perim= 6.0' r= 1.00' n= 0.040 Earth, cobble bottom, clean sides
61.0	2,225	Total			

Subcatchment EXDA1ND: EXDA-1

Hydrograph

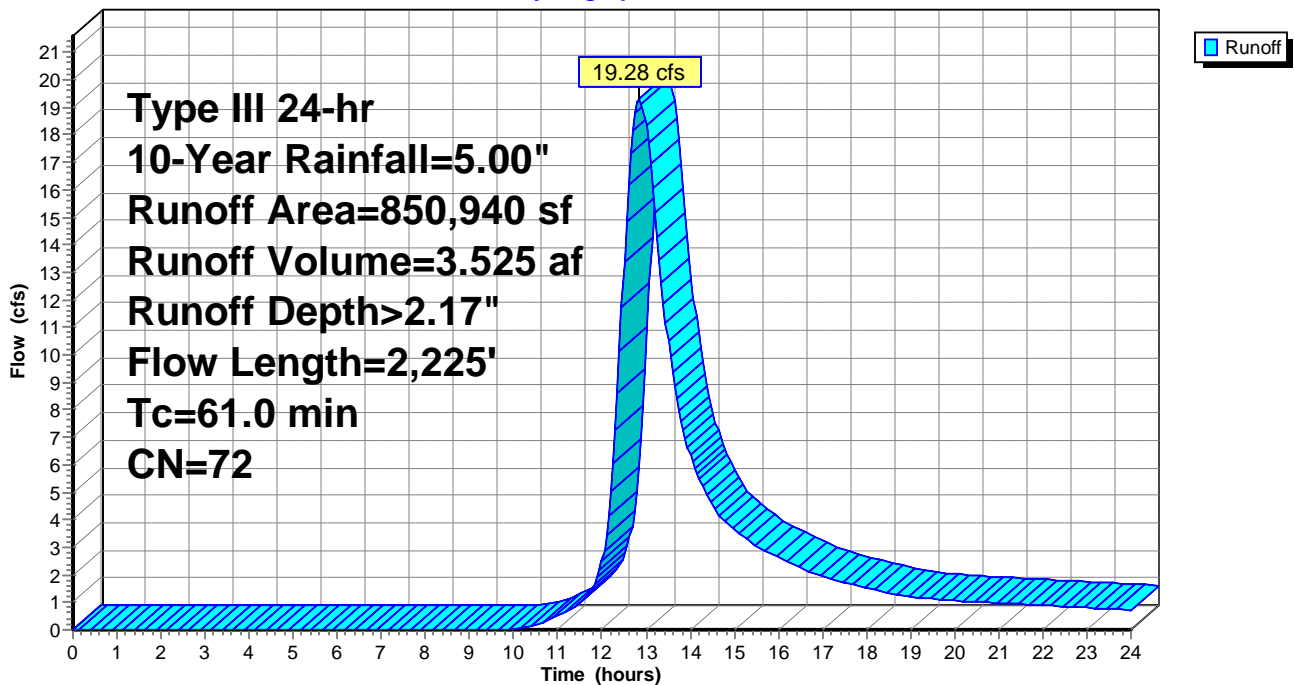

Summary for Subcatchment EXDA2AND: EXDA-2A

Runoff = 3.96 cfs @ 12.41 hrs, Volume= 0.490 af, Depth> 2.18"

Runoff by SCS TR-20 method, UH=SCS, Weighted-CN, Time Span= 0.00-24.00 hrs, dt= 0.05 hrs
 Type III 24-hr 10-Year Rainfall=5.00"

Area (sf)	CN	Description
60,051	70	Woods, Good, HSG C
57,315	74	Pasture/grassland/range, Good, HSG C
117,366	72	Weighted Average
117,366		100.00% Pervious Area

Tc (min)	Length (feet)	Slope (ft/ft)	Velocity (ft/sec)	Capacity (cfs)	Description
27.1	250	0.0700	0.15		Sheet Flow, Woods: Light underbrush n= 0.400 P2= 3.20"
1.4	200	0.2150	2.32		Shallow Concentrated Flow, Woodland Kv= 5.0 fps
28.5	450	Total			

Subcatchment EXDA2AND: EXDA-2A

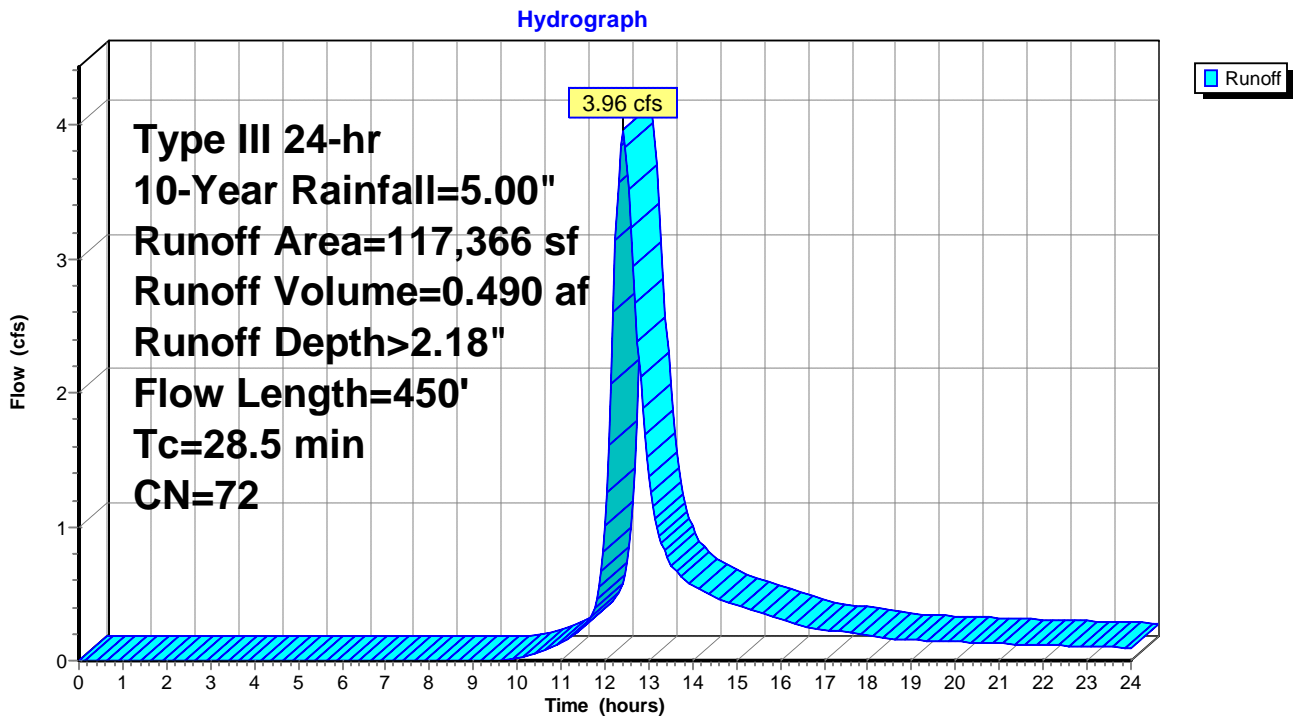

Summary for Subcatchment EXDA2BND: EXDA-2B

Runoff = 4.45 cfs @ 12.67 hrs, Volume= 0.706 af, Depth> 2.01"

Runoff by SCS TR-20 method, UH=SCS, Weighted-CN, Time Span= 0.00-24.00 hrs, dt= 0.05 hrs
 Type III 24-hr 10-Year Rainfall=5.00"

Area (sf)	CN	Description
179,894	70	Woods, Good, HSG C
3,377	74	Pasture/grassland/range, Good, HSG C
183,271	70	Weighted Average
183,271		100.00% Pervious Area

Tc (min)	Length (feet)	Slope (ft/ft)	Velocity (ft/sec)	Capacity (cfs)	Description
36.1	250	0.0340	0.12		Sheet Flow, Woods: Light underbrush n= 0.400 P2= 3.20"
10.6	800	0.0637	1.26		Shallow Concentrated Flow, Woodland Kv= 5.0 fps
46.7	1,050	Total			

Subcatchment EXDA2BND: EXDA-2B

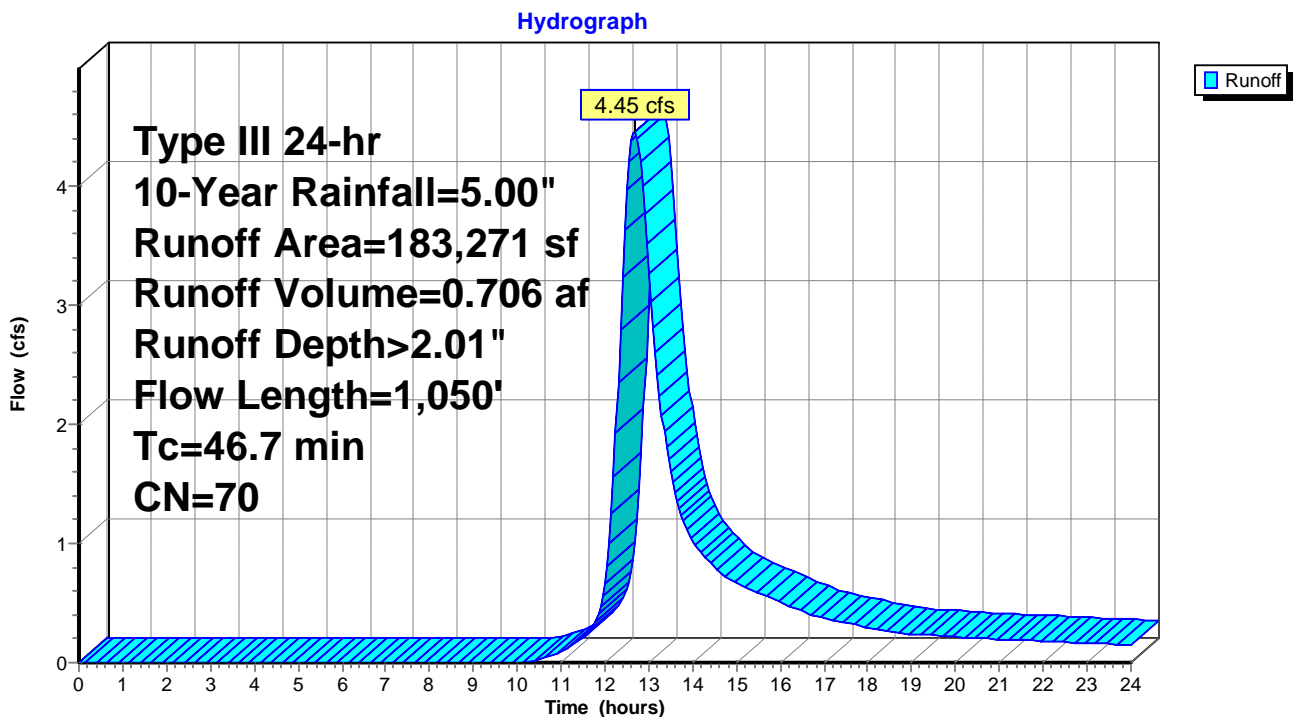

Summary for Subcatchment EXDA3ND: EXDA-3

Runoff = 6.97 cfs @ 12.49 hrs, Volume= 0.939 af, Depth> 2.26"

Runoff by SCS TR-20 method, UH=SCS, Weighted-CN, Time Span= 0.00-24.00 hrs, dt= 0.05 hrs
 Type III 24-hr 10-Year Rainfall=5.00"

Area (sf)	CN	Description
56,418	70	Woods, Good, HSG C
132,061	71	Meadow, non-grazed, HSG C
11,996	74	Pasture/grassland/range, Good, HSG C
16,497	98	Impervious, HSG C
216,972	73	Weighted Average
200,475		92.40% Pervious Area
16,497		7.60% Impervious Area

Tc (min)	Length (feet)	Slope (ft/ft)	Velocity (ft/sec)	Capacity (cfs)	Description
30.5	250	0.0520	0.14		Sheet Flow, Woods: Light underbrush n= 0.400 P2= 3.20"
4.0	360	0.0889	1.49		Shallow Concentrated Flow, Woodland Kv= 5.0 fps

34.5 610 Total

Subcatchment EXDA3ND: EXDA-3

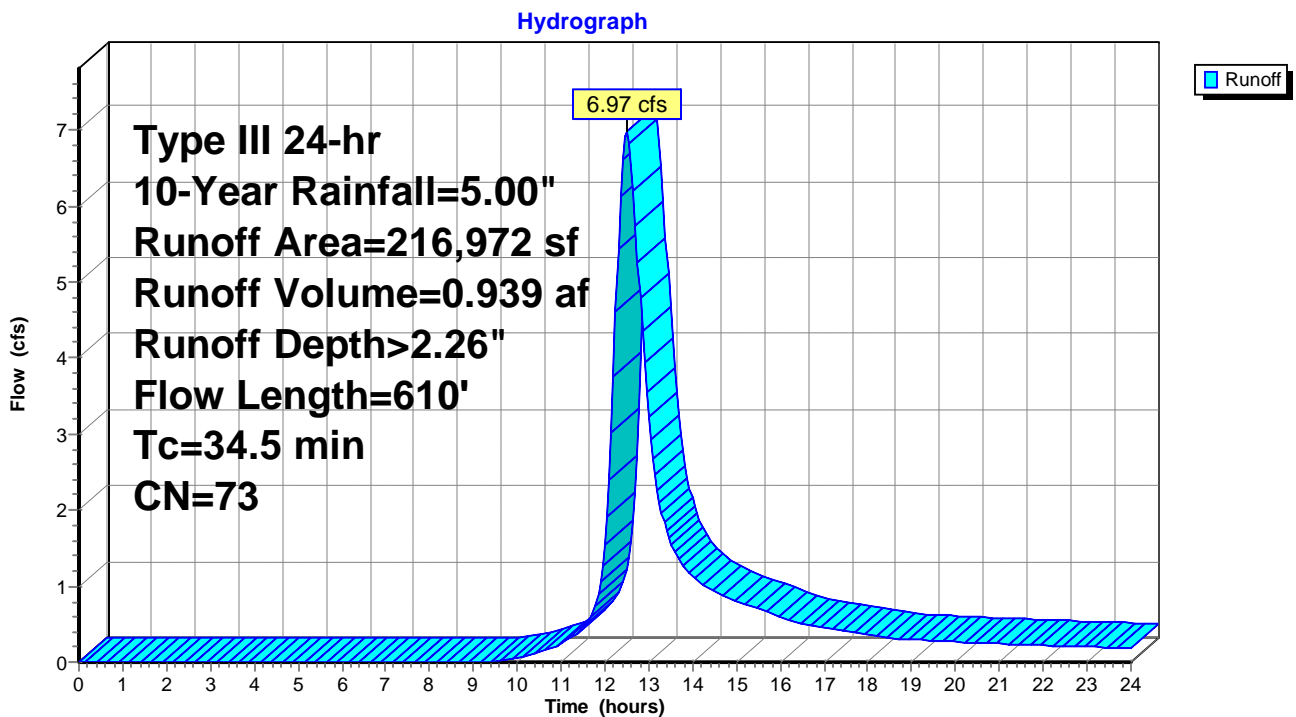

Summary for Subcatchment EXDA4ND: EXDA-4

Runoff = 1.94 cfs @ 12.19 hrs, Volume= 0.175 af, Depth> 2.36"

Runoff by SCS TR-20 method, UH=SCS, Weighted-CN, Time Span= 0.00-24.00 hrs, dt= 0.05 hrs
 Type III 24-hr 10-Year Rainfall=5.00"

Area (sf)	CN	Description
21,726	74	Pasture/grassland/range, Good, HSG C
15,178	71	Meadow, non-grazed, HSG C
* 1,997	98	Impervious
38,901	74	Weighted Average
36,904		94.87% Pervious Area
1,997		5.13% Impervious Area

Tc (min)	Length (feet)	Slope (ft/ft)	Velocity (ft/sec)	Capacity (cfs)	Description
11.8	200	0.0500	0.28		Sheet Flow, Grass: Short n= 0.150 P2= 3.20"
1.2	200	0.1500	2.71		Shallow Concentrated Flow, Short Grass Pasture Kv= 7.0 fps
13.0	400	Total			

Subcatchment EXDA4ND: EXDA-4

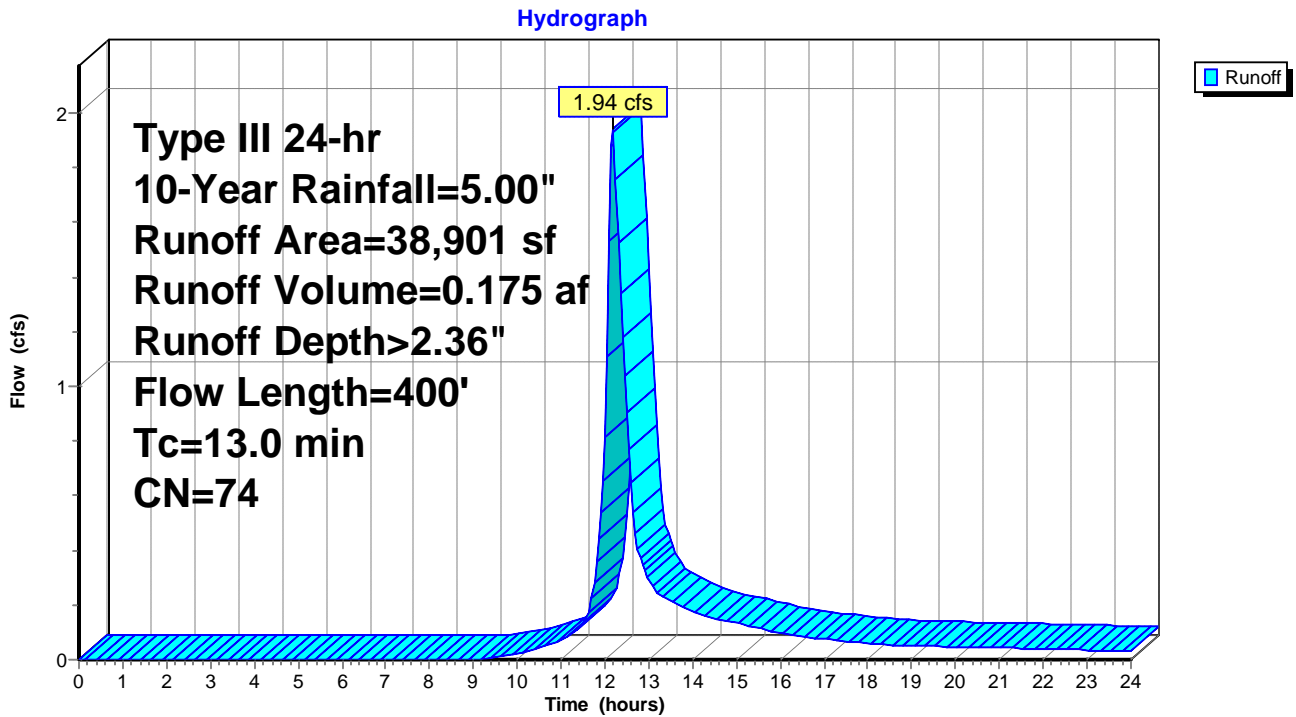

Summary for Subcatchment EXDA5ND: EXDA-5

Runoff = 4.52 cfs @ 12.16 hrs, Volume= 0.385 af, Depth> 2.62"

Runoff by SCS TR-20 method, UH=SCS, Weighted-CN, Time Span= 0.00-24.00 hrs, dt= 0.05 hrs
 Type III 24-hr 10-Year Rainfall=5.00"

Area (sf)	CN	Description
9,039	98	Impervious, HSG C
67,792	74	Pasture/grassland/range, Good, HSG C
76,831	77	Weighted Average
67,792		88.24% Pervious Area
9,039		11.76% Impervious Area

Tc (min)	Length (feet)	Slope (ft/ft)	Velocity (ft/sec)	Capacity (cfs)	Description
10.3	150	0.0400	0.24		Sheet Flow, Grass: Short n= 0.150 P2= 3.20"
1.0	350	0.1350	5.92		Shallow Concentrated Flow, Unpaved Kv= 16.1 fps

11.3 500 Total

Subcatchment EXDA5ND: EXDA-5

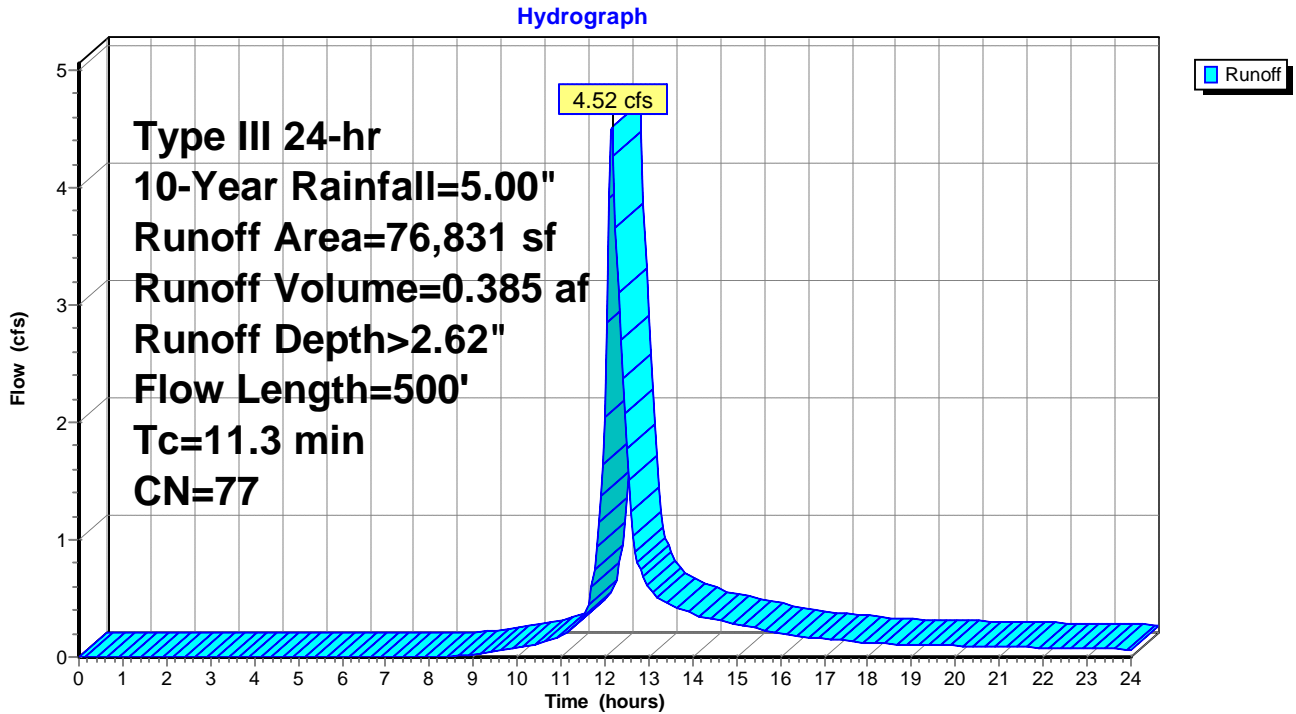

Summary for Subcatchment EXDA6ND: EXDA-6

Runoff = 3.74 cfs @ 12.12 hrs, Volume= 0.292 af, Depth> 2.45"

Runoff by SCS TR-20 method, UH=SCS, Weighted-CN, Time Span= 0.00-24.00 hrs, dt= 0.05 hrs
 Type III 24-hr 10-Year Rainfall=5.00"

Area (sf)	CN	Description
60,704	74	Pasture/grassland/range, Good, HSG C
1,796	98	Impervious, HSG C
62,500	75	Weighted Average
60,704		97.13% Pervious Area
1,796		2.87% Impervious Area

Tc (min)	Length (feet)	Slope (ft/ft)	Velocity (ft/sec)	Capacity (cfs)	Description
7.7	100	0.0360	0.22		Sheet Flow, Grass: Short n= 0.150 P2= 3.20"
0.6	250	0.2050	7.29		Shallow Concentrated Flow, Unpaved Kv= 16.1 fps
8.3	350	Total			

Subcatchment EXDA6ND: EXDA-6

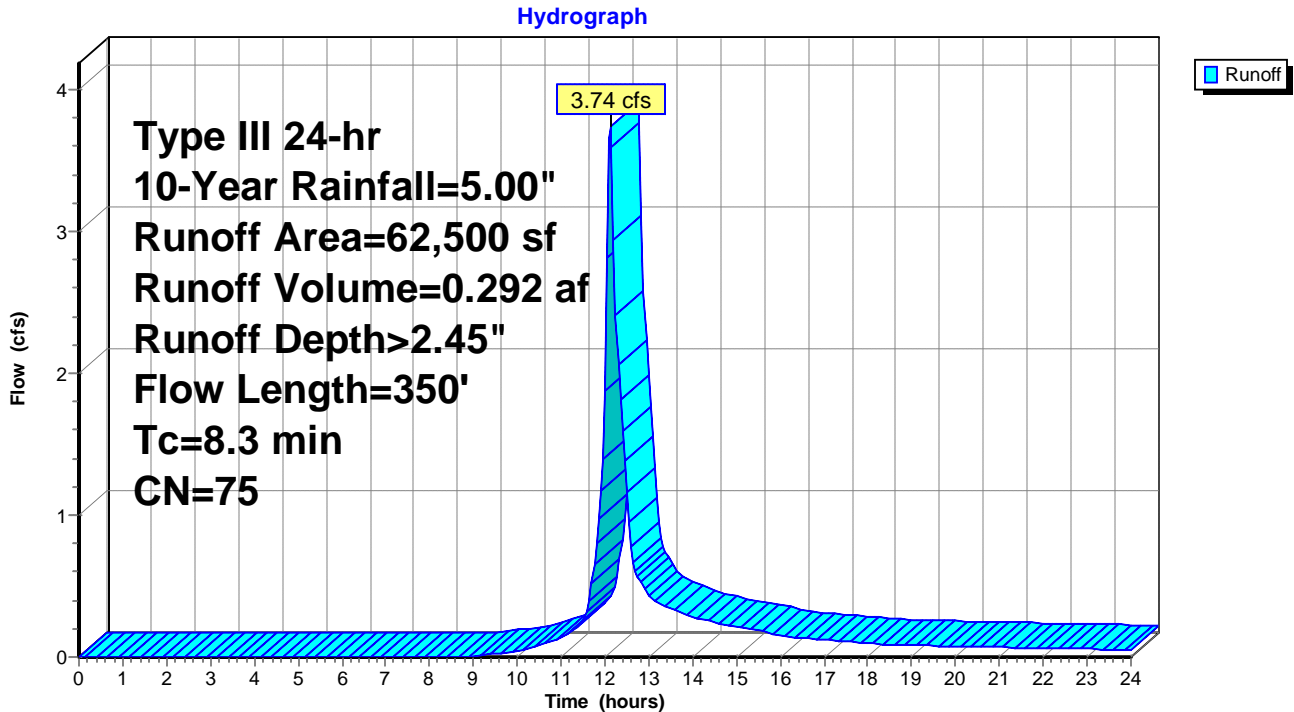

Summary for Link DP1: DP-1

Inflow Area = 19.535 ac, 5.77% Impervious, Inflow Depth > 2.17" for 10-Year event
Inflow = 19.28 cfs @ 12.84 hrs, Volume= 3.525 af
Primary = 19.28 cfs @ 12.84 hrs, Volume= 3.525 af, Atten= 0%, Lag= 0.0 min

Primary outflow = Inflow, Time Span= 0.00-24.00 hrs, dt= 0.05 hrs

Link DP1: DP-1

Hydrograph

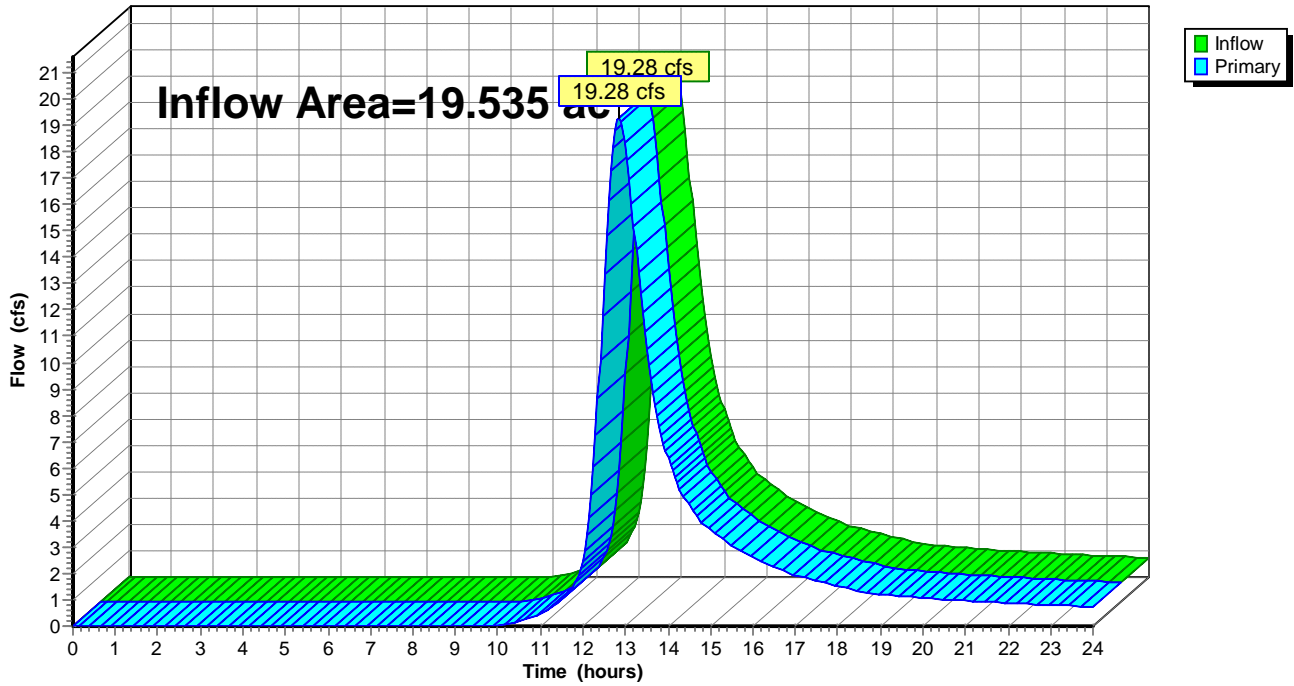

Summary for Link DP2A: DP-2A

Inflow Area = 2.694 ac, 0.00% Impervious, Inflow Depth > 2.18" for 10-Year event
Inflow = 3.96 cfs @ 12.41 hrs, Volume= 0.490 af
Primary = 3.96 cfs @ 12.41 hrs, Volume= 0.490 af, Atten= 0%, Lag= 0.0 min

Primary outflow = Inflow, Time Span= 0.00-24.00 hrs, dt= 0.05 hrs

Link DP2A: DP-2A

Hydrograph

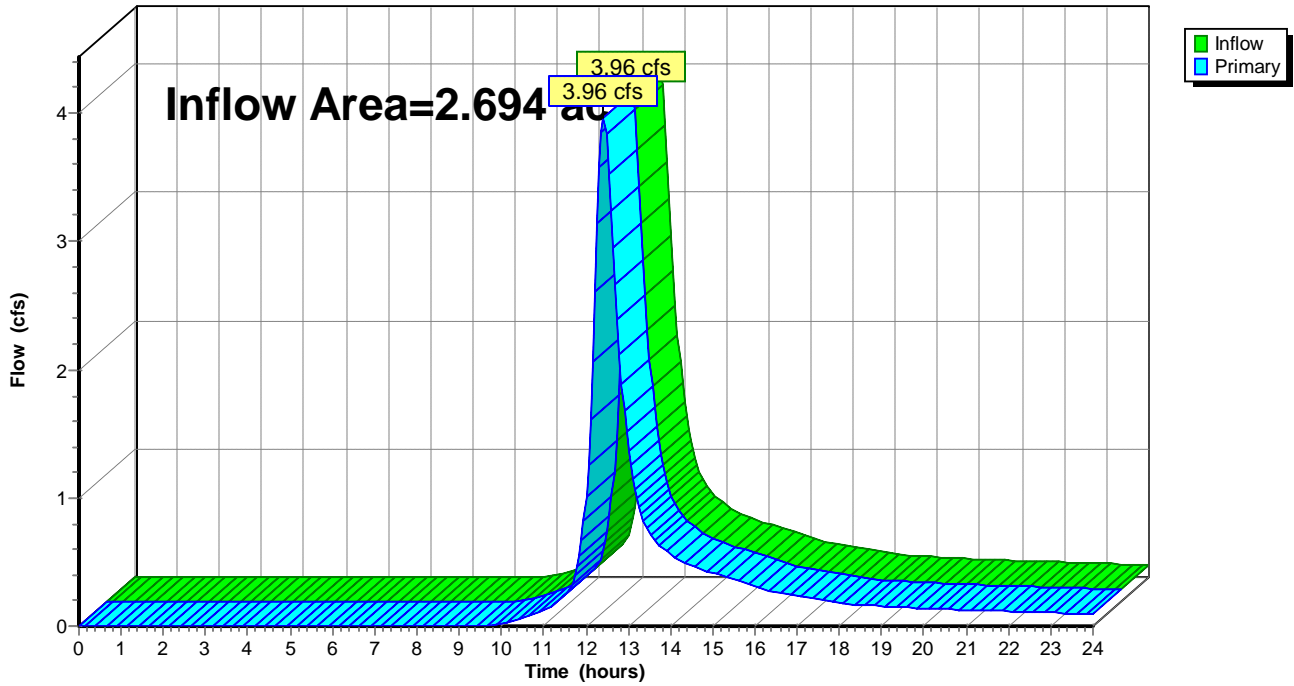

Summary for Link DP2B: DP-2B

Inflow Area = 4.207 ac, 0.00% Impervious, Inflow Depth > 2.01" for 10-Year event
Inflow = 4.45 cfs @ 12.67 hrs, Volume= 0.706 af
Primary = 4.45 cfs @ 12.67 hrs, Volume= 0.706 af, Atten= 0%, Lag= 0.0 min

Primary outflow = Inflow, Time Span= 0.00-24.00 hrs, dt= 0.05 hrs

Link DP2B: DP-2B

Hydrograph

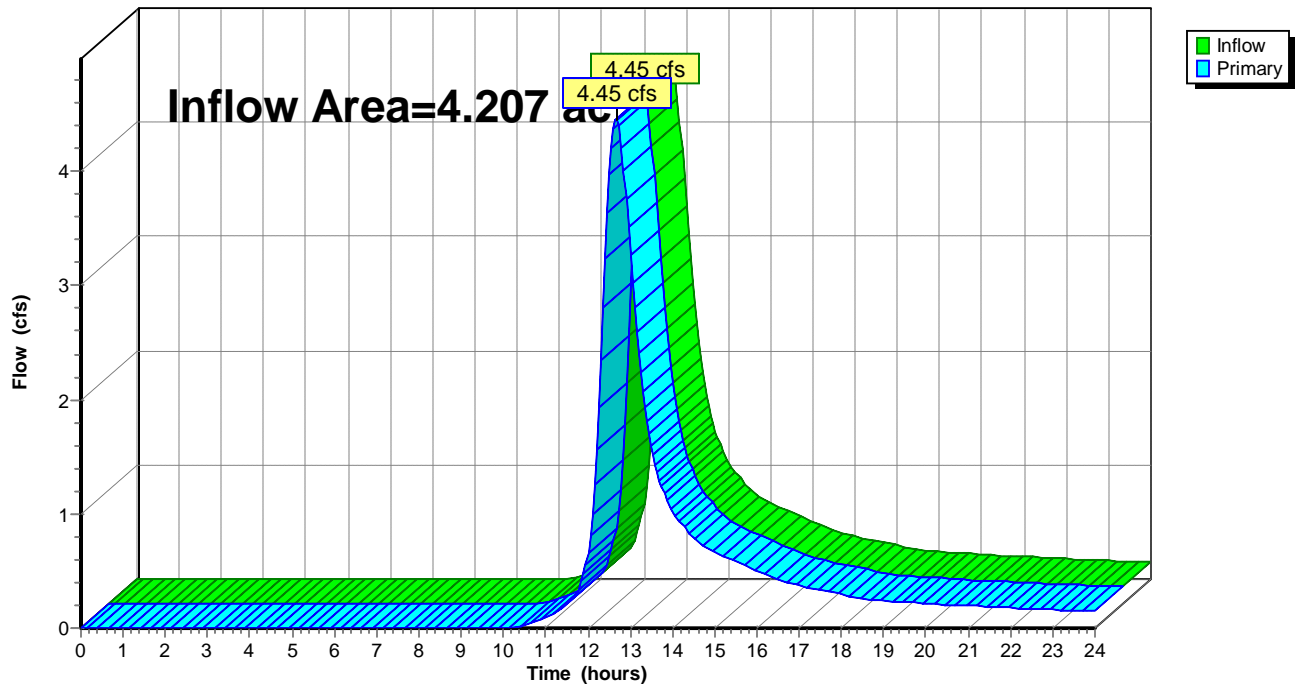

Summary for Link DP3: DP-3

Inflow Area = 4.981 ac, 7.60% Impervious, Inflow Depth > 2.26" for 10-Year event
Inflow = 6.97 cfs @ 12.49 hrs, Volume= 0.939 af
Primary = 6.97 cfs @ 12.49 hrs, Volume= 0.939 af, Atten= 0%, Lag= 0.0 min

Primary outflow = Inflow, Time Span= 0.00-24.00 hrs, dt= 0.05 hrs

Link DP3: DP-3

Hydrograph

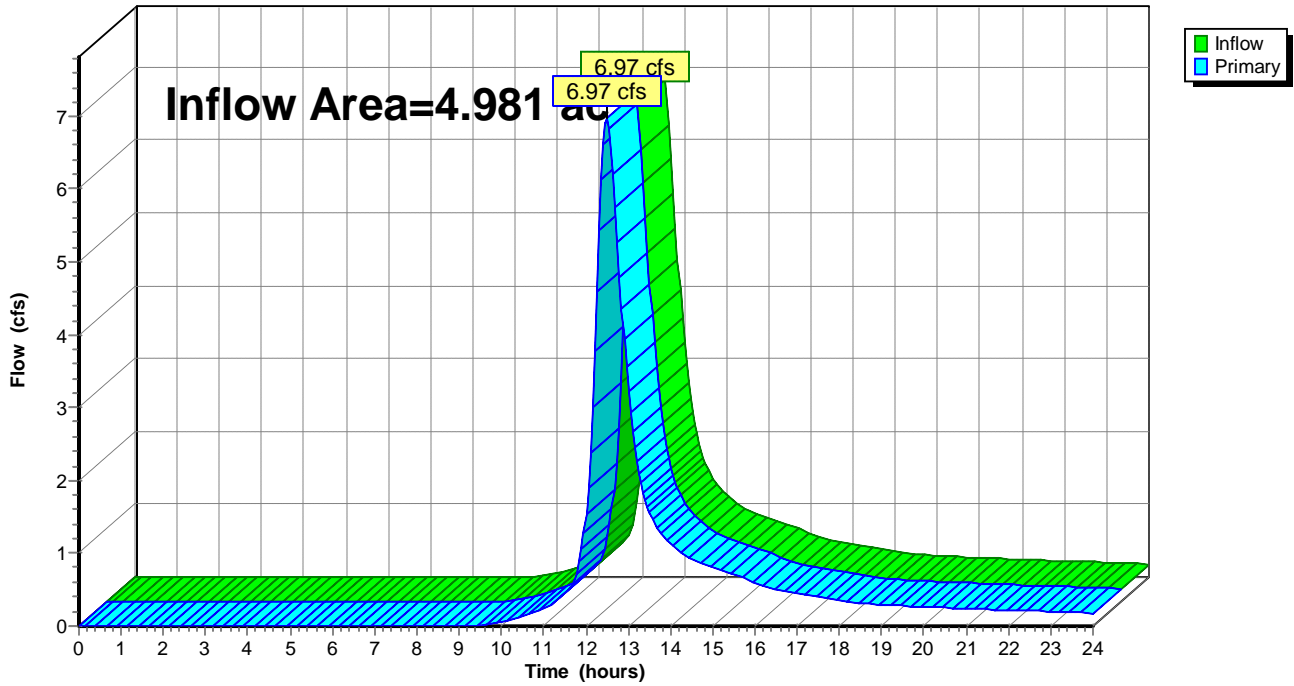

Summary for Link DP4: DP-4

Inflow Area = 0.893 ac, 5.13% Impervious, Inflow Depth > 2.36" for 10-Year event
Inflow = 1.94 cfs @ 12.19 hrs, Volume= 0.175 af
Primary = 1.94 cfs @ 12.19 hrs, Volume= 0.175 af, Atten= 0%, Lag= 0.0 min

Primary outflow = Inflow, Time Span= 0.00-24.00 hrs, dt= 0.05 hrs

Link DP4: DP-4

Hydrograph

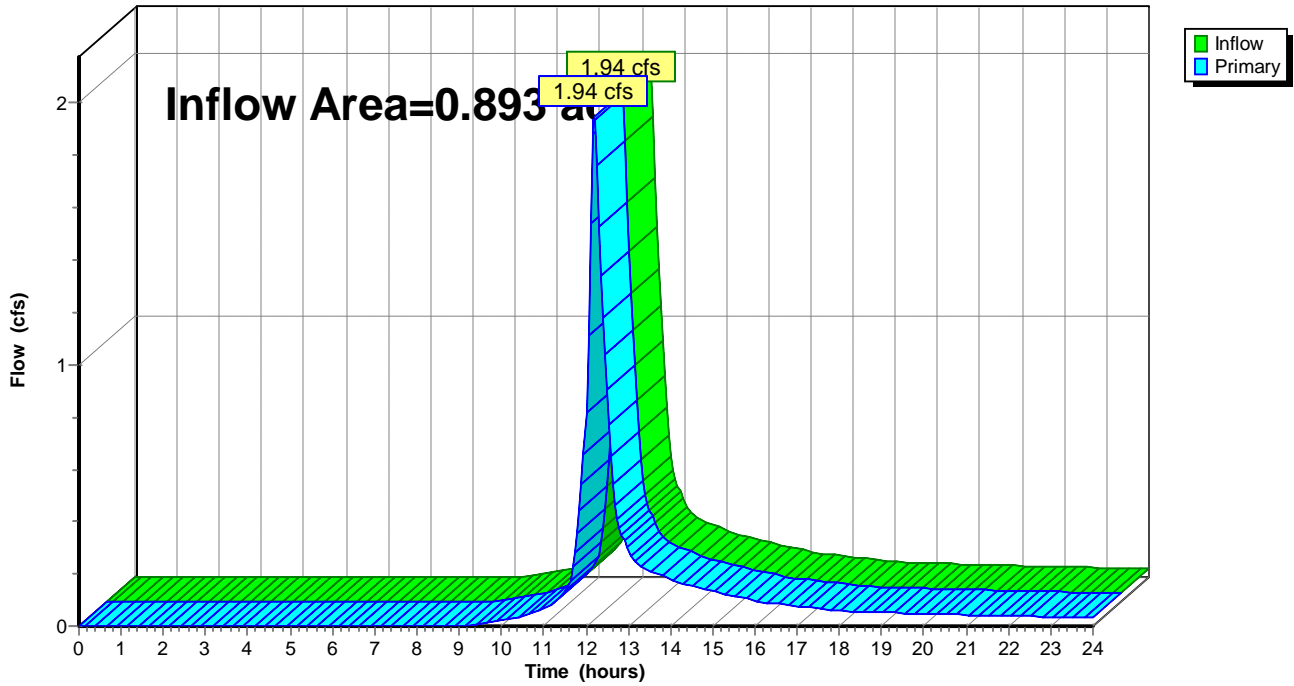

Summary for Link DP5: DP-5

Inflow Area = 1.764 ac, 11.76% Impervious, Inflow Depth > 2.62" for 10-Year event
Inflow = 4.52 cfs @ 12.16 hrs, Volume= 0.385 af
Primary = 4.52 cfs @ 12.16 hrs, Volume= 0.385 af, Atten= 0%, Lag= 0.0 min

Primary outflow = Inflow, Time Span= 0.00-24.00 hrs, dt= 0.05 hrs

Link DP5: DP-5

Hydrograph

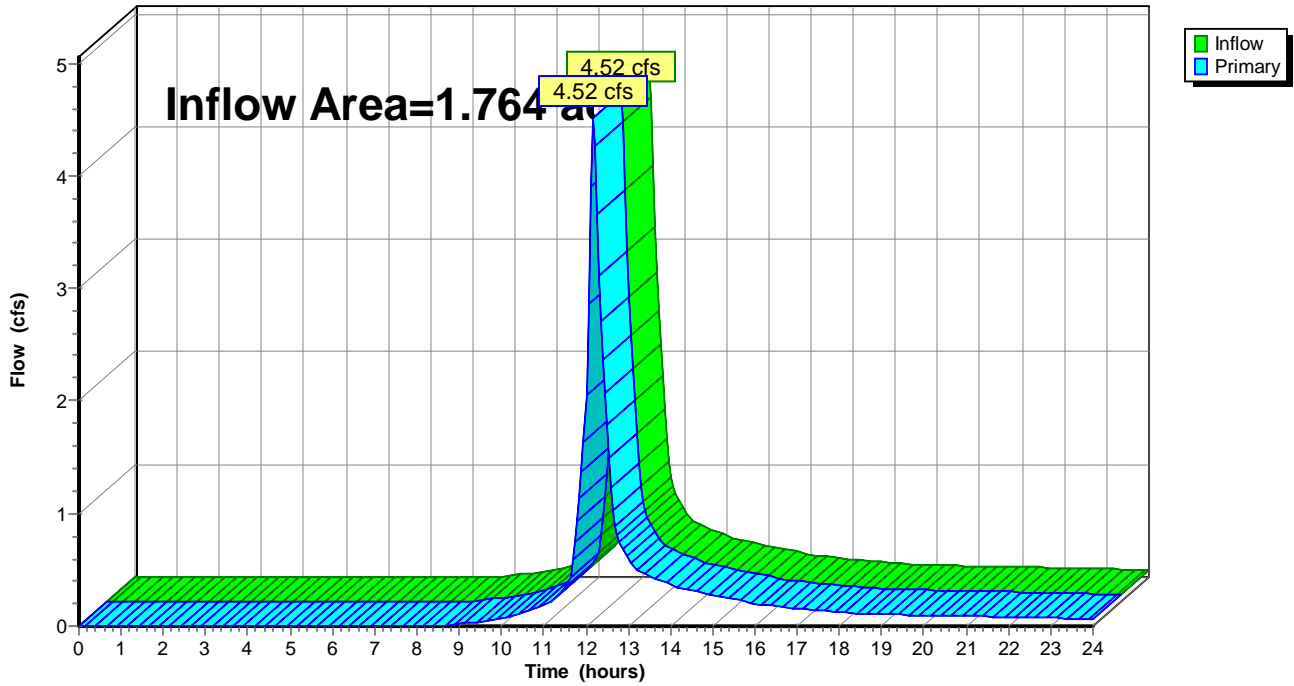

Summary for Link DP6: DP-6

Inflow Area = 1.435 ac, 2.87% Impervious, Inflow Depth > 2.45" for 10-Year event
Inflow = 3.74 cfs @ 12.12 hrs, Volume= 0.292 af
Primary = 3.74 cfs @ 12.12 hrs, Volume= 0.292 af, Atten= 0%, Lag= 0.0 min

Primary outflow = Inflow, Time Span= 0.00-24.00 hrs, dt= 0.05 hrs

Link DP6: DP-6

Hydrograph

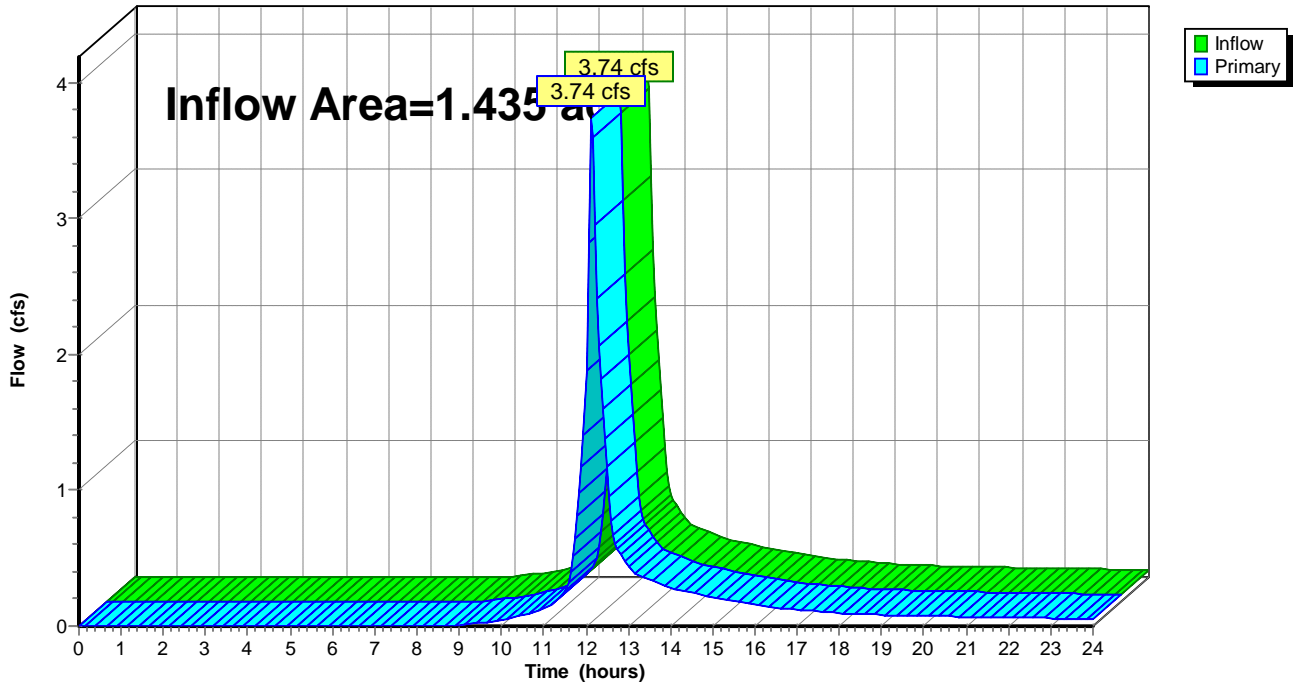

Time span=0.00-24.00 hrs, dt=0.05 hrs, 481 points
 Runoff by SCS TR-20 method, UH=SCS, Weighted-CN
 Reach routing by Stor-Ind+Trans method - Pond routing by Stor-Ind method

Subcatchment EXDA1ND: EXDA-1	Runoff Area=850,940 sf 5.77% Impervious Runoff Depth>2.63" Flow Length=2,225' Tc=61.0 min CN=72 Runoff=23.60 cfs 4.284 af
Subcatchment EXDA2AND: EXDA-2A	Runoff Area=117,366 sf 0.00% Impervious Runoff Depth>2.65" Flow Length=450' Tc=28.5 min CN=72 Runoff=4.84 cfs 0.596 af
Subcatchment EXDA2BND: EXDA-2B	Runoff Area=183,271 sf 0.00% Impervious Runoff Depth>2.46" Flow Length=1,050' Tc=46.7 min CN=70 Runoff=5.50 cfs 0.864 af
Subcatchment EXDA3ND: EXDA-3	Runoff Area=216,972 sf 7.60% Impervious Runoff Depth>2.74" Flow Length=610' Tc=34.5 min CN=73 Runoff=8.48 cfs 1.137 af
Subcatchment EXDA4ND: EXDA-4	Runoff Area=38,901 sf 5.13% Impervious Runoff Depth>2.84" Flow Length=400' Tc=13.0 min CN=74 Runoff=2.35 cfs 0.212 af
Subcatchment EXDA5ND: EXDA-5	Runoff Area=76,831 sf 11.76% Impervious Runoff Depth>3.13" Flow Length=500' Tc=11.3 min CN=77 Runoff=5.40 cfs 0.459 af
Subcatchment EXDA6ND: EXDA-6	Runoff Area=62,500 sf 2.87% Impervious Runoff Depth>2.94" Flow Length=350' Tc=8.3 min CN=75 Runoff=4.51 cfs 0.352 af
Link DP1: DP-1	Inflow=23.60 cfs 4.284 af Primary=23.60 cfs 4.284 af
Link DP2A: DP-2A	Inflow=4.84 cfs 0.596 af Primary=4.84 cfs 0.596 af
Link DP2B: DP-2B	Inflow=5.50 cfs 0.864 af Primary=5.50 cfs 0.864 af
Link DP3: DP-3	Inflow=8.48 cfs 1.137 af Primary=8.48 cfs 1.137 af
Link DP4: DP-4	Inflow=2.35 cfs 0.212 af Primary=2.35 cfs 0.212 af
Link DP5: DP-5	Inflow=5.40 cfs 0.459 af Primary=5.40 cfs 0.459 af
Link DP6: DP-6	Inflow=4.51 cfs 0.352 af Primary=4.51 cfs 0.352 af

Total Runoff Area = 35.509 ac Runoff Volume = 7.904 af Average Runoff Depth = 2.67"
 94.93% Pervious = 33.708 ac 5.07% Impervious = 1.801 ac

Summary for Subcatchment EXDA1ND: EXDA-1

Runoff = 23.60 cfs @ 12.84 hrs, Volume= 4.284 af, Depth> 2.63"

Runoff by SCS TR-20 method, UH=SCS, Weighted-CN, Time Span= 0.00-24.00 hrs, dt= 0.05 hrs
 Type III 24-hr 25-Year Rainfall=5.60"

Area (sf)	CN	Description
635,511	70	Woods, Good, HSG C
148,147	74	Pasture/grassland/range, Good, HSG C
18,170	71	Meadow, non-grazed, HSG C
49,112	98	Impervious, HSG C
850,940	72	Weighted Average
801,828		94.23% Pervious Area
49,112		5.77% Impervious Area

Tc (min)	Length (feet)	Slope (ft/ft)	Velocity (ft/sec)	Capacity (cfs)	Description
37.0	250	0.0320	0.11		Sheet Flow, Woods: Light underbrush n= 0.400 P2= 3.20"
23.0	1,450	0.0440	1.05		Shallow Concentrated Flow, Woodland Kv= 5.0 fps
1.0	525	0.0570	8.87	53.22	Channel Flow, Area= 6.0 sf Perim= 6.0' r= 1.00' n= 0.040 Earth, cobble bottom, clean sides
61.0	2,225	Total			

Subcatchment EXDA1ND: EXDA-1

Hydrograph

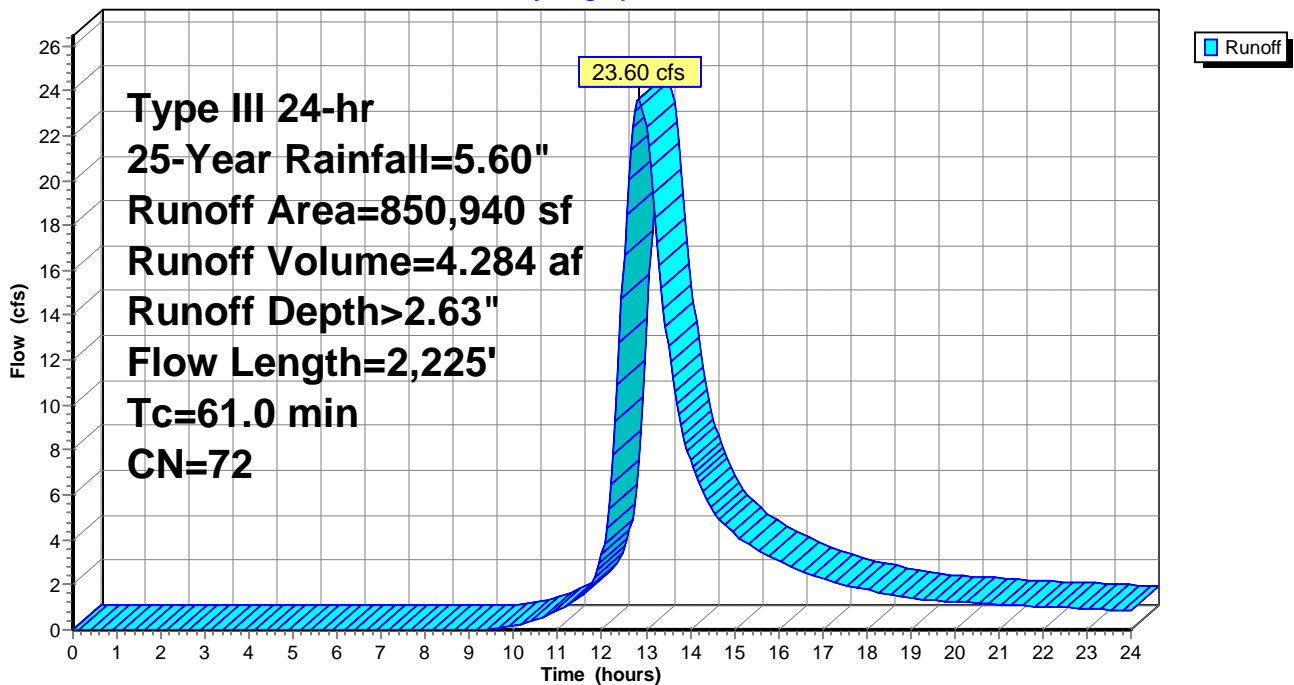

Summary for Subcatchment EXDA2AND: EXDA-2A

Runoff = 4.84 cfs @ 12.41 hrs, Volume= 0.596 af, Depth> 2.65"

Runoff by SCS TR-20 method, UH=SCS, Weighted-CN, Time Span= 0.00-24.00 hrs, dt= 0.05 hrs
 Type III 24-hr 25-Year Rainfall=5.60"

Area (sf)	CN	Description
60,051	70	Woods, Good, HSG C
57,315	74	Pasture/grassland/range, Good, HSG C
117,366	72	Weighted Average
117,366		100.00% Pervious Area

Tc (min)	Length (feet)	Slope (ft/ft)	Velocity (ft/sec)	Capacity (cfs)	Description
27.1	250	0.0700	0.15		Sheet Flow, Woods: Light underbrush n= 0.400 P2= 3.20"
1.4	200	0.2150	2.32		Shallow Concentrated Flow, Woodland Kv= 5.0 fps
28.5	450	Total			

Subcatchment EXDA2AND: EXDA-2A

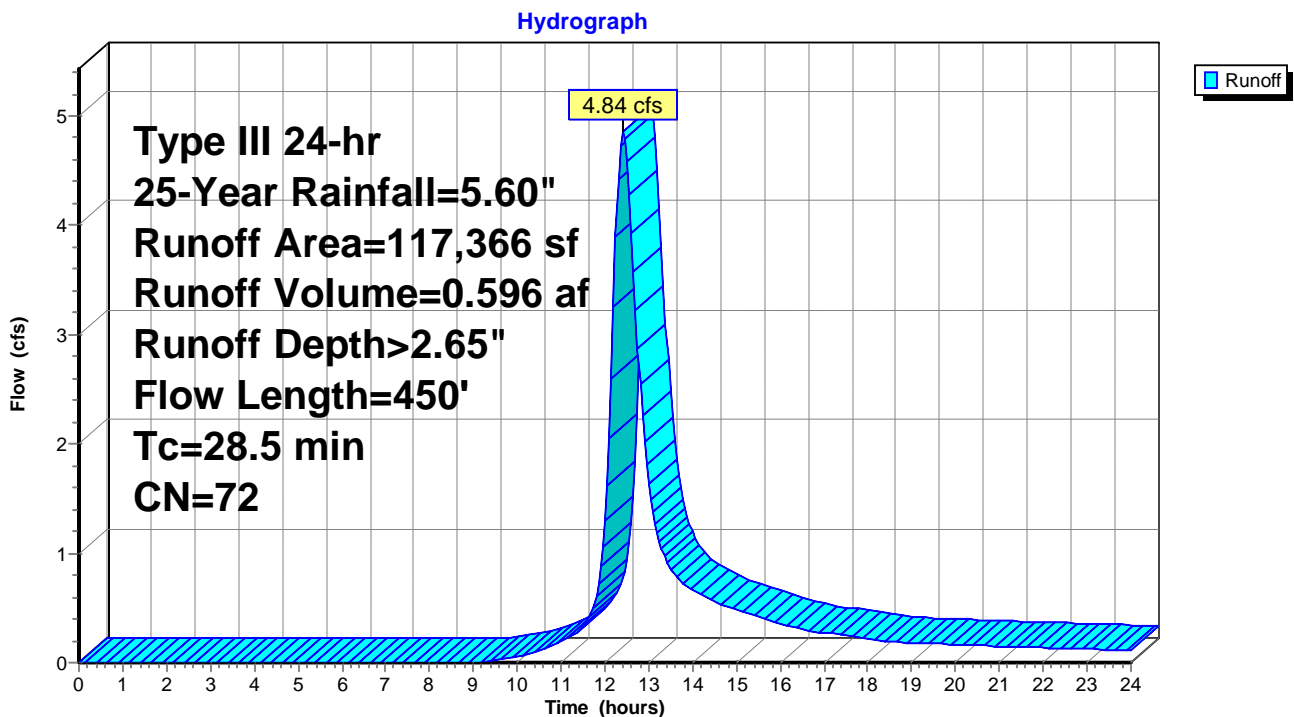

Summary for Subcatchment EXDA2BND: EXDA-2B

Runoff = 5.50 cfs @ 12.66 hrs, Volume= 0.864 af, Depth> 2.46"

Runoff by SCS TR-20 method, UH=SCS, Weighted-CN, Time Span= 0.00-24.00 hrs, dt= 0.05 hrs
 Type III 24-hr 25-Year Rainfall=5.60"

Area (sf)	CN	Description
179,894	70	Woods, Good, HSG C
3,377	74	Pasture/grassland/range, Good, HSG C
183,271	70	Weighted Average
183,271		100.00% Pervious Area

Tc (min)	Length (feet)	Slope (ft/ft)	Velocity (ft/sec)	Capacity (cfs)	Description
36.1	250	0.0340	0.12		Sheet Flow, Woods: Light underbrush n= 0.400 P2= 3.20"
10.6	800	0.0637	1.26		Shallow Concentrated Flow, Woodland Kv= 5.0 fps
46.7	1,050	Total			

Subcatchment EXDA2BND: EXDA-2B

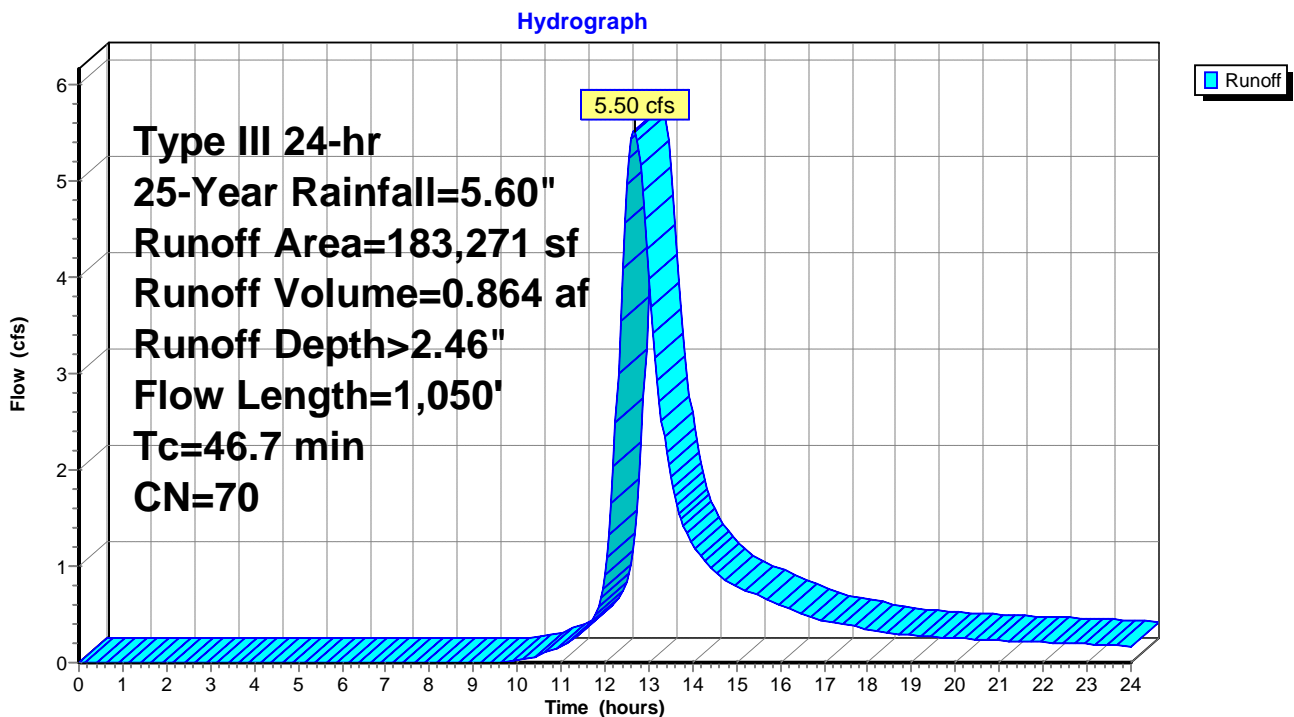

Summary for Subcatchment EXDA3ND: EXDA-3

Runoff = 8.48 cfs @ 12.49 hrs, Volume= 1.137 af, Depth> 2.74"

Runoff by SCS TR-20 method, UH=SCS, Weighted-CN, Time Span= 0.00-24.00 hrs, dt= 0.05 hrs
 Type III 24-hr 25-Year Rainfall=5.60"

Area (sf)	CN	Description
56,418	70	Woods, Good, HSG C
132,061	71	Meadow, non-grazed, HSG C
11,996	74	Pasture/grassland/range, Good, HSG C
16,497	98	Impervious, HSG C
216,972	73	Weighted Average
200,475		92.40% Pervious Area
16,497		7.60% Impervious Area

Tc (min)	Length (feet)	Slope (ft/ft)	Velocity (ft/sec)	Capacity (cfs)	Description
30.5	250	0.0520	0.14		Sheet Flow, Woods: Light underbrush n= 0.400 P2= 3.20"
4.0	360	0.0889	1.49		Shallow Concentrated Flow, Woodland Kv= 5.0 fps

34.5 610 Total

Subcatchment EXDA3ND: EXDA-3

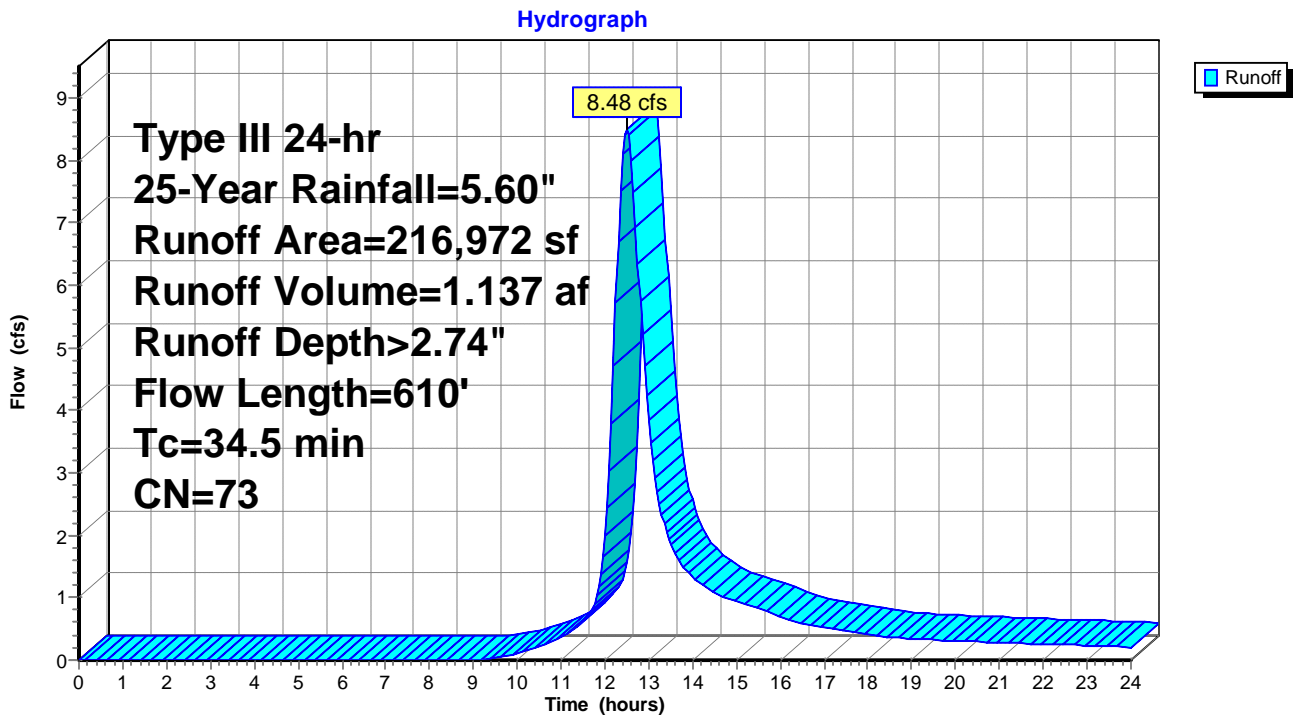

Summary for Subcatchment EXDA4ND: EXDA-4

Runoff = 2.35 cfs @ 12.19 hrs, Volume= 0.212 af, Depth> 2.84"

Runoff by SCS TR-20 method, UH=SCS, Weighted-CN, Time Span= 0.00-24.00 hrs, dt= 0.05 hrs
 Type III 24-hr 25-Year Rainfall=5.60"

Area (sf)	CN	Description
21,726	74	Pasture/grassland/range, Good, HSG C
15,178	71	Meadow, non-grazed, HSG C
* 1,997	98	Impervious
38,901	74	Weighted Average
36,904		94.87% Pervious Area
1,997		5.13% Impervious Area

Tc (min)	Length (feet)	Slope (ft/ft)	Velocity (ft/sec)	Capacity (cfs)	Description
11.8	200	0.0500	0.28		Sheet Flow, Grass: Short n= 0.150 P2= 3.20"
1.2	200	0.1500	2.71		Shallow Concentrated Flow, Short Grass Pasture Kv= 7.0 fps
13.0	400	Total			

Subcatchment EXDA4ND: EXDA-4

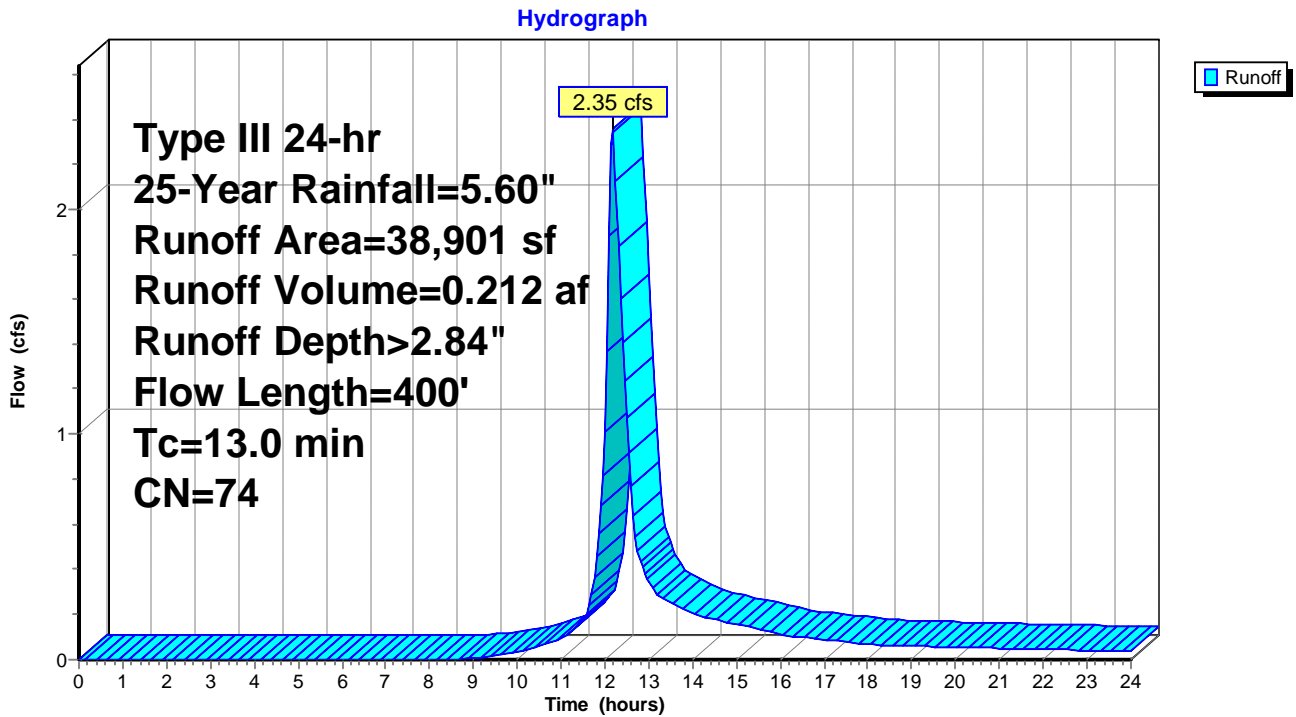

Summary for Subcatchment EXDA5ND: EXDA-5

Runoff = 5.40 cfs @ 12.16 hrs, Volume= 0.459 af, Depth> 3.13"

Runoff by SCS TR-20 method, UH=SCS, Weighted-CN, Time Span= 0.00-24.00 hrs, dt= 0.05 hrs
 Type III 24-hr 25-Year Rainfall=5.60"

Area (sf)	CN	Description
9,039	98	Impervious, HSG C
67,792	74	Pasture/grassland/range, Good, HSG C
76,831	77	Weighted Average
67,792		88.24% Pervious Area
9,039		11.76% Impervious Area

Tc (min)	Length (feet)	Slope (ft/ft)	Velocity (ft/sec)	Capacity (cfs)	Description
10.3	150	0.0400	0.24		Sheet Flow, Grass: Short n= 0.150 P2= 3.20"
1.0	350	0.1350	5.92		Shallow Concentrated Flow, Unpaved Kv= 16.1 fps

11.3 500 Total

Subcatchment EXDA5ND: EXDA-5

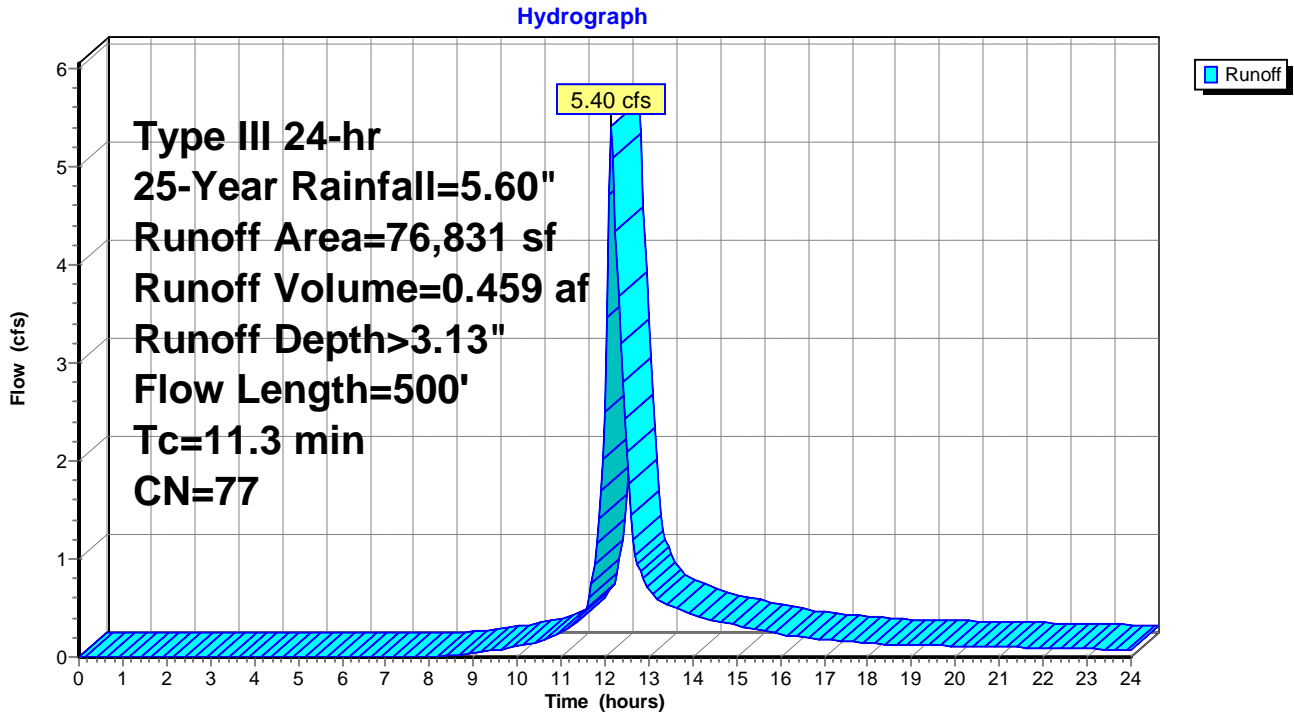

Summary for Subcatchment EXDA6ND: EXDA-6

Runoff = 4.51 cfs @ 12.12 hrs, Volume= 0.352 af, Depth> 2.94"

Runoff by SCS TR-20 method, UH=SCS, Weighted-CN, Time Span= 0.00-24.00 hrs, dt= 0.05 hrs
 Type III 24-hr 25-Year Rainfall=5.60"

Area (sf)	CN	Description
60,704	74	Pasture/grassland/range, Good, HSG C
1,796	98	Impervious, HSG C
62,500	75	Weighted Average
60,704		97.13% Pervious Area
1,796		2.87% Impervious Area

Tc (min)	Length (feet)	Slope (ft/ft)	Velocity (ft/sec)	Capacity (cfs)	Description
7.7	100	0.0360	0.22		Sheet Flow, Grass: Short n= 0.150 P2= 3.20"
0.6	250	0.2050	7.29		Shallow Concentrated Flow, Unpaved Kv= 16.1 fps
8.3	350	Total			

Subcatchment EXDA6ND: EXDA-6

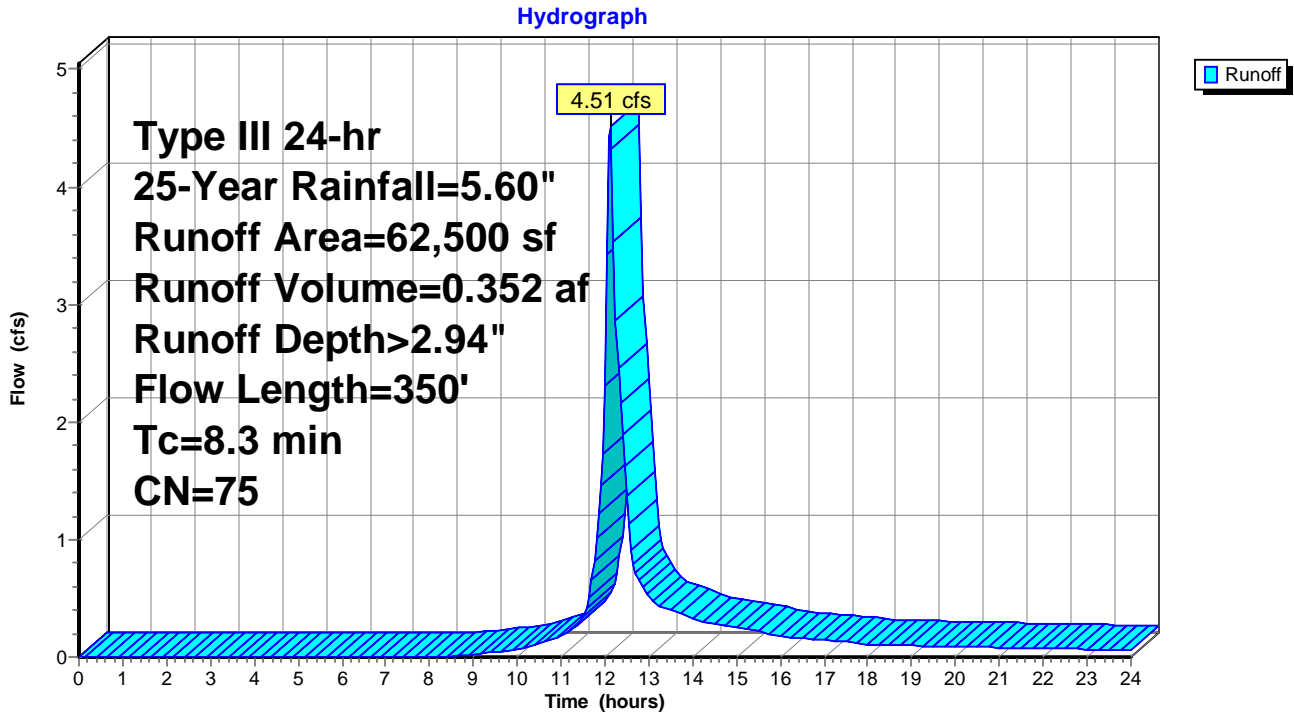

Summary for Link DP1: DP-1

Inflow Area = 19.535 ac, 5.77% Impervious, Inflow Depth > 2.63" for 25-Year event
Inflow = 23.60 cfs @ 12.84 hrs, Volume= 4.284 af
Primary = 23.60 cfs @ 12.84 hrs, Volume= 4.284 af, Atten= 0%, Lag= 0.0 min

Primary outflow = Inflow, Time Span= 0.00-24.00 hrs, dt= 0.05 hrs

Link DP1: DP-1

Hydrograph

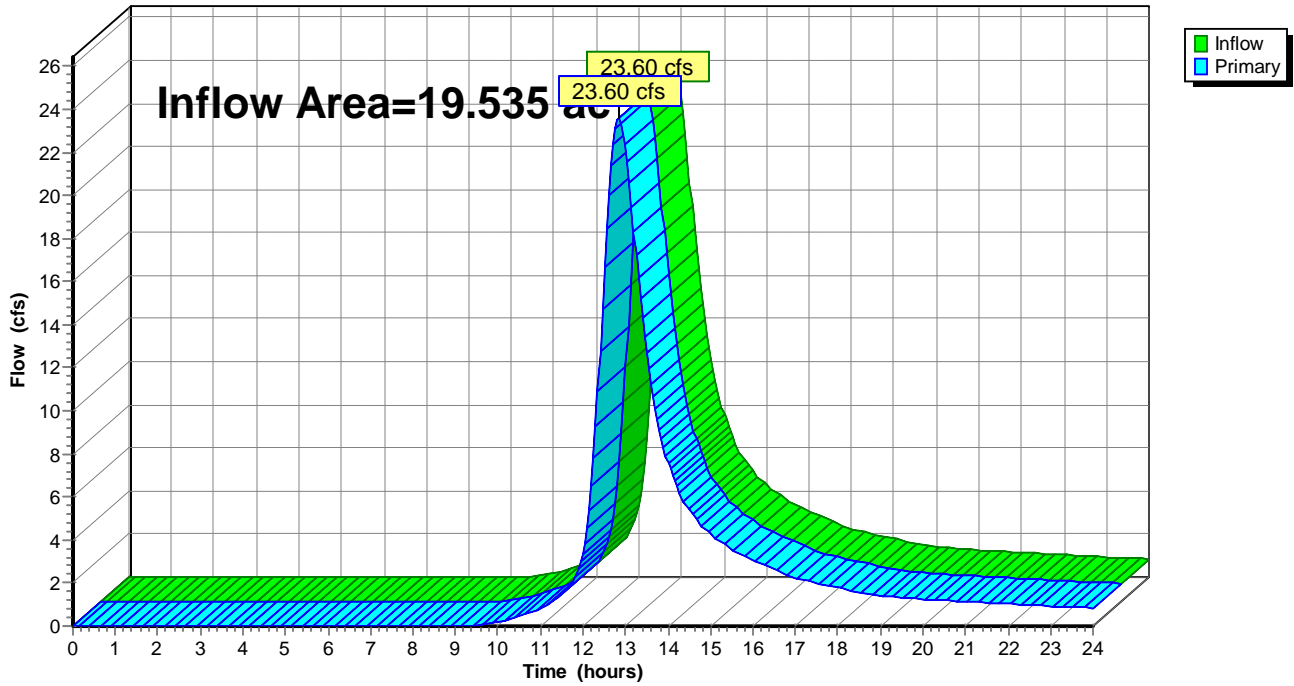

Summary for Link DP2A: DP-2A

Inflow Area = 2.694 ac, 0.00% Impervious, Inflow Depth > 2.65" for 25-Year event
Inflow = 4.84 cfs @ 12.41 hrs, Volume= 0.596 af
Primary = 4.84 cfs @ 12.41 hrs, Volume= 0.596 af, Atten= 0%, Lag= 0.0 min

Primary outflow = Inflow, Time Span= 0.00-24.00 hrs, dt= 0.05 hrs

Link DP2A: DP-2A

Hydrograph

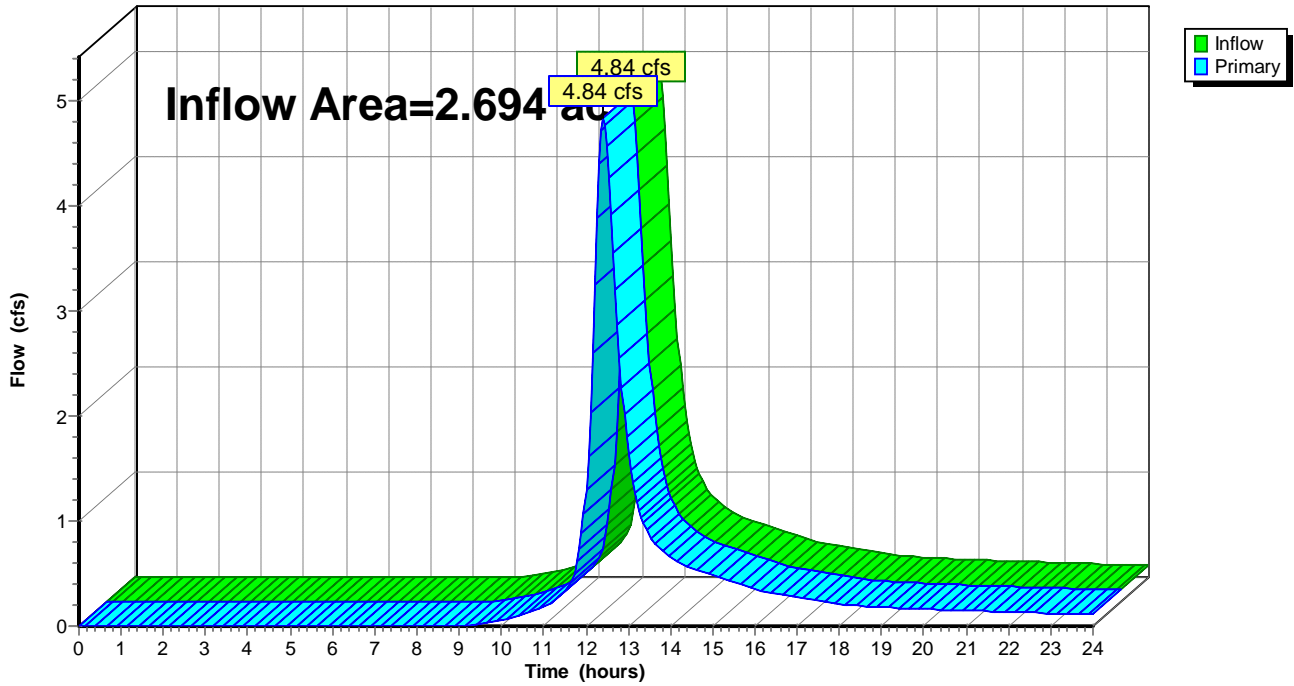

Summary for Link DP2B: DP-2B

Inflow Area = 4.207 ac, 0.00% Impervious, Inflow Depth > 2.46" for 25-Year event
Inflow = 5.50 cfs @ 12.66 hrs, Volume= 0.864 af
Primary = 5.50 cfs @ 12.66 hrs, Volume= 0.864 af, Atten= 0%, Lag= 0.0 min

Primary outflow = Inflow, Time Span= 0.00-24.00 hrs, dt= 0.05 hrs

Link DP2B: DP-2B

Hydrograph

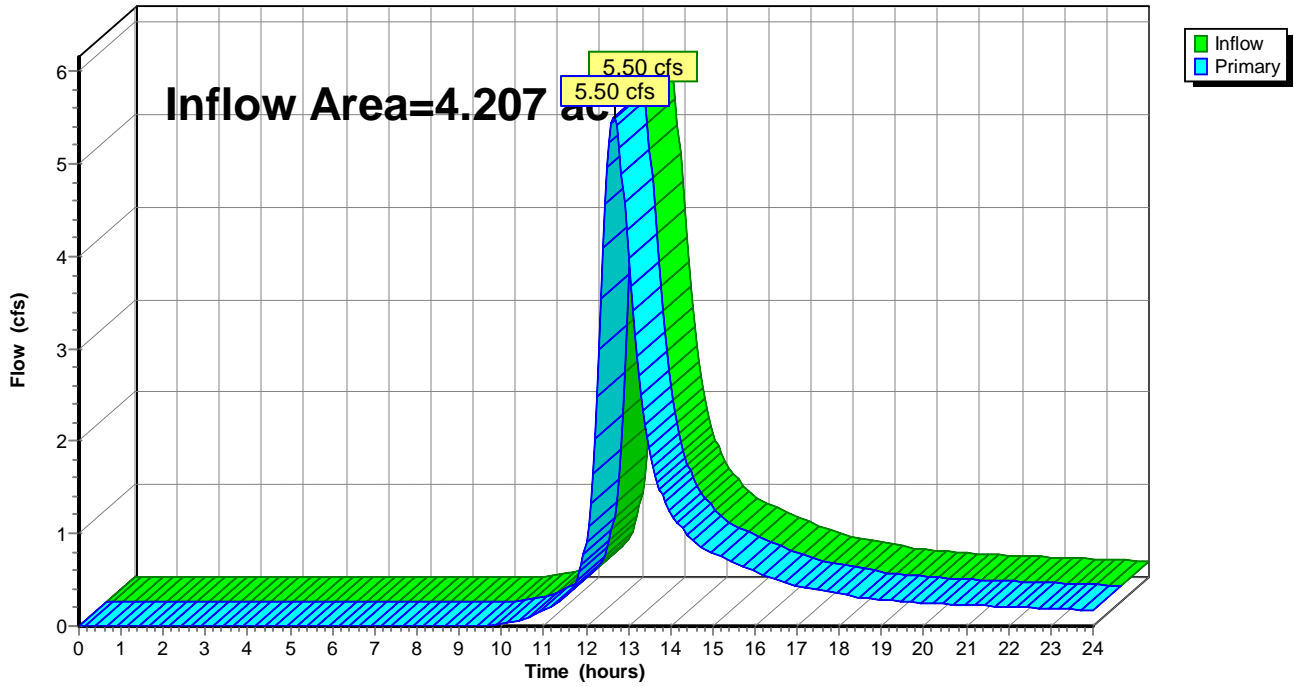

Summary for Link DP3: DP-3

Inflow Area = 4.981 ac, 7.60% Impervious, Inflow Depth > 2.74" for 25-Year event
Inflow = 8.48 cfs @ 12.49 hrs, Volume= 1.137 af
Primary = 8.48 cfs @ 12.49 hrs, Volume= 1.137 af, Atten= 0%, Lag= 0.0 min

Primary outflow = Inflow, Time Span= 0.00-24.00 hrs, dt= 0.05 hrs

Link DP3: DP-3

Hydrograph

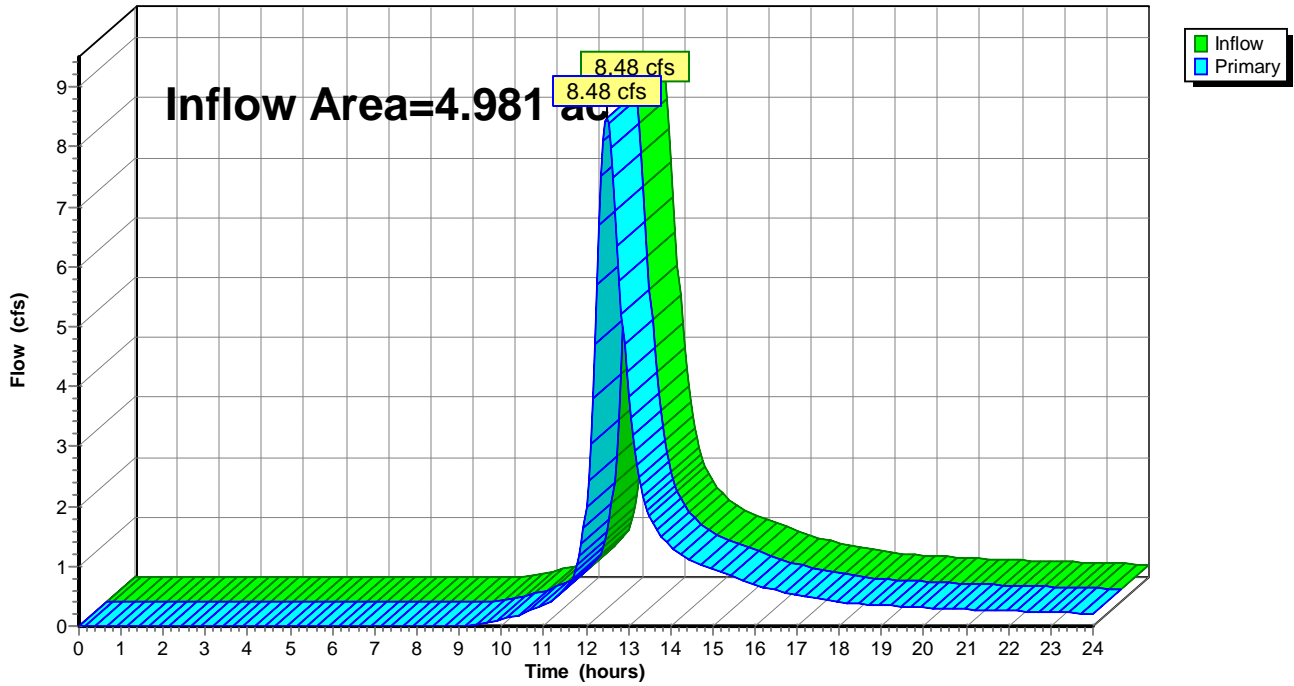

Summary for Link DP4: DP-4

Inflow Area = 0.893 ac, 5.13% Impervious, Inflow Depth > 2.84" for 25-Year event
Inflow = 2.35 cfs @ 12.19 hrs, Volume= 0.212 af
Primary = 2.35 cfs @ 12.19 hrs, Volume= 0.212 af, Atten= 0%, Lag= 0.0 min

Primary outflow = Inflow, Time Span= 0.00-24.00 hrs, dt= 0.05 hrs

Link DP4: DP-4

Hydrograph

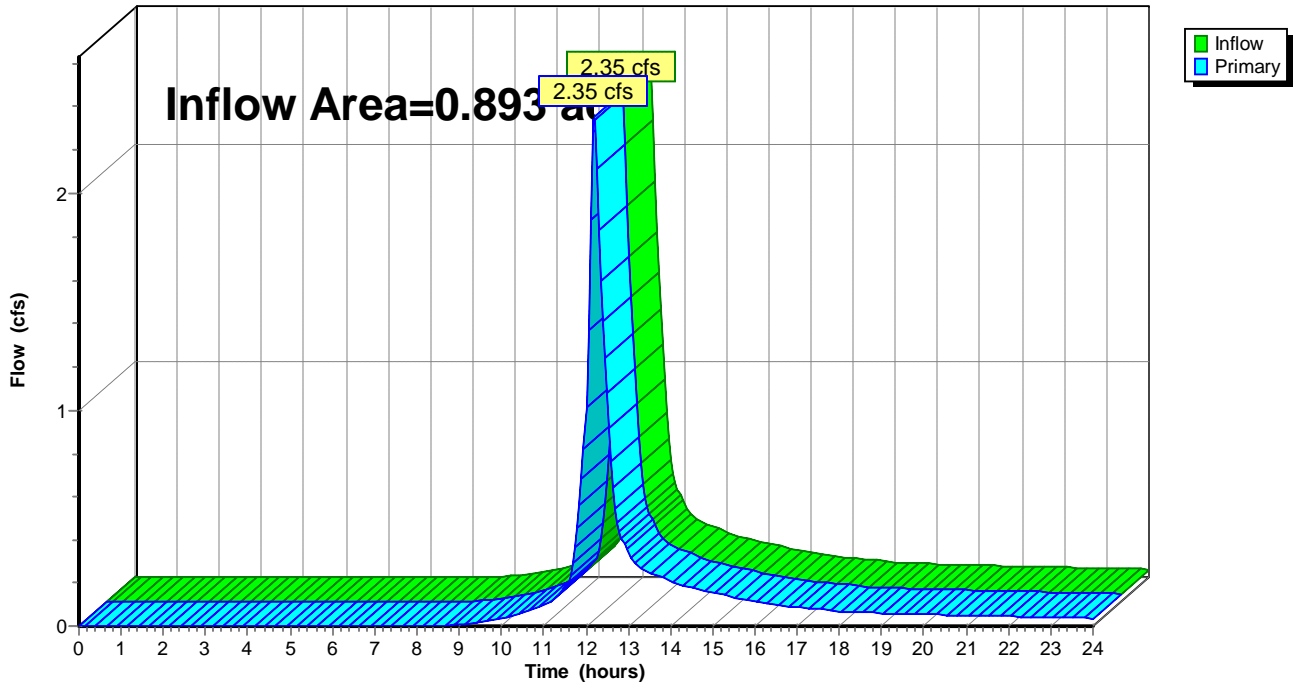

Summary for Link DP5: DP-5

Inflow Area = 1.764 ac, 11.76% Impervious, Inflow Depth > 3.13" for 25-Year event
Inflow = 5.40 cfs @ 12.16 hrs, Volume= 0.459 af
Primary = 5.40 cfs @ 12.16 hrs, Volume= 0.459 af, Atten= 0%, Lag= 0.0 min

Primary outflow = Inflow, Time Span= 0.00-24.00 hrs, dt= 0.05 hrs

Link DP5: DP-5

Hydrograph

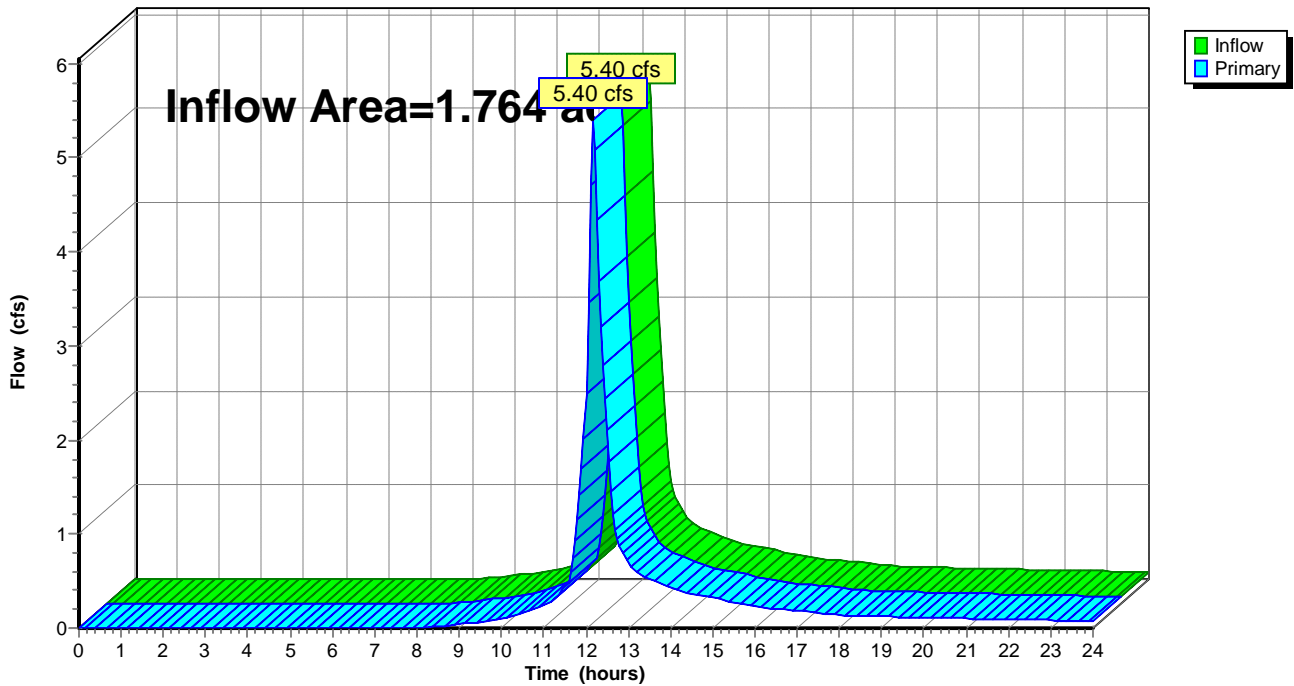

Summary for Link DP6: DP-6

Inflow Area = 1.435 ac, 2.87% Impervious, Inflow Depth > 2.94" for 25-Year event
Inflow = 4.51 cfs @ 12.12 hrs, Volume= 0.352 af
Primary = 4.51 cfs @ 12.12 hrs, Volume= 0.352 af, Atten= 0%, Lag= 0.0 min

Primary outflow = Inflow, Time Span= 0.00-24.00 hrs, dt= 0.05 hrs

Link DP6: DP-6

Hydrograph

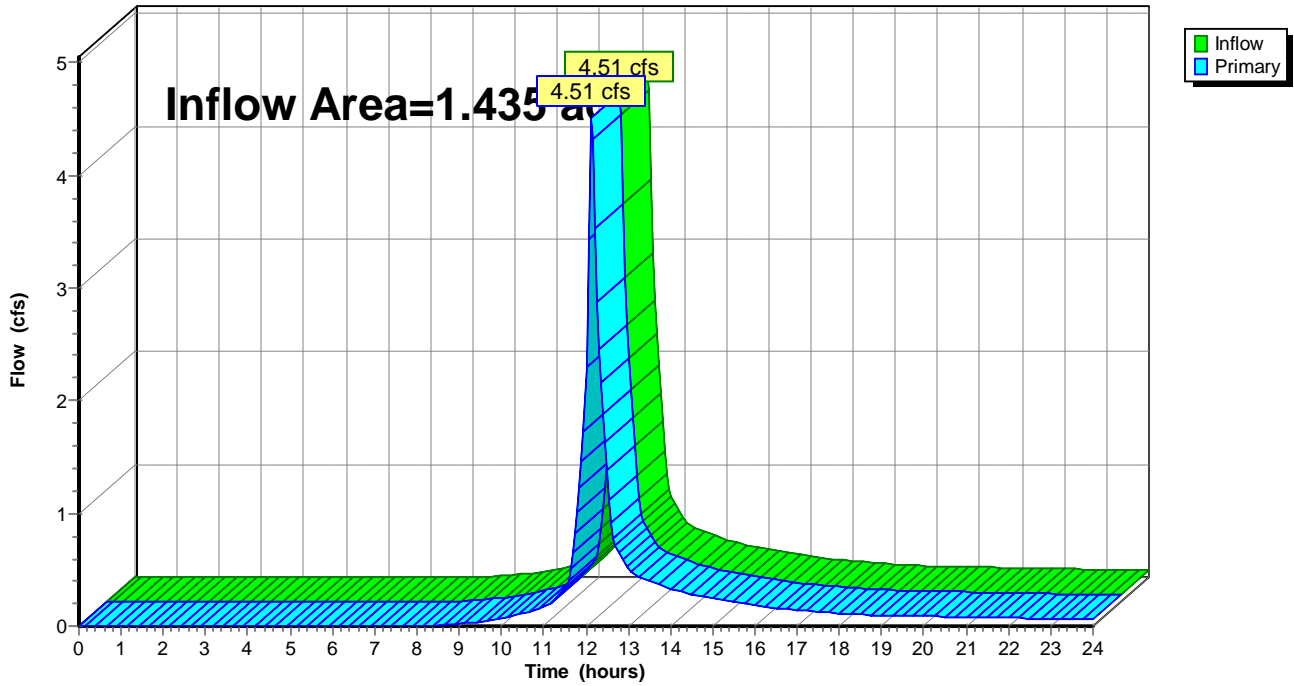

Time span=0.00-24.00 hrs, dt=0.05 hrs, 481 points
 Runoff by SCS TR-20 method, UH=SCS, Weighted-CN
 Reach routing by Stor-Ind+Trans method - Pond routing by Stor-Ind method

Subcatchment EXDA1ND: EXDA-1	Runoff Area=850,940 sf 5.77% Impervious Runoff Depth>3.20" Flow Length=2,225' Tc=61.0 min CN=72 Runoff=28.81 cfs 5.204 af
Subcatchment EXDA2AND: EXDA-2A	Runoff Area=117,366 sf 0.00% Impervious Runoff Depth>3.22" Flow Length=450' Tc=28.5 min CN=72 Runoff=5.90 cfs 0.723 af
Subcatchment EXDA2BND: EXDA-2B	Runoff Area=183,271 sf 0.00% Impervious Runoff Depth>3.01" Flow Length=1,050' Tc=46.7 min CN=70 Runoff=6.77 cfs 1.057 af
Subcatchment EXDA3ND: EXDA-3	Runoff Area=216,972 sf 7.60% Impervious Runoff Depth>3.32" Flow Length=610' Tc=34.5 min CN=73 Runoff=10.30 cfs 1.376 af
Subcatchment EXDA4ND: EXDA-4	Runoff Area=38,901 sf 5.13% Impervious Runoff Depth>3.43" Flow Length=400' Tc=13.0 min CN=74 Runoff=2.84 cfs 0.255 af
Subcatchment EXDA5ND: EXDA-5	Runoff Area=76,831 sf 11.76% Impervious Runoff Depth>3.74" Flow Length=500' Tc=11.3 min CN=77 Runoff=6.45 cfs 0.549 af
Subcatchment EXDA6ND: EXDA-6	Runoff Area=62,500 sf 2.87% Impervious Runoff Depth>3.53" Flow Length=350' Tc=8.3 min CN=75 Runoff=5.43 cfs 0.423 af
Link DP1: DP-1	Inflow=28.81 cfs 5.204 af Primary=28.81 cfs 5.204 af
Link DP2A: DP-2A	Inflow=5.90 cfs 0.723 af Primary=5.90 cfs 0.723 af
Link DP2B: DP-2B	Inflow=6.77 cfs 1.057 af Primary=6.77 cfs 1.057 af
Link DP3: DP-3	Inflow=10.30 cfs 1.376 af Primary=10.30 cfs 1.376 af
Link DP4: DP-4	Inflow=2.84 cfs 0.255 af Primary=2.84 cfs 0.255 af
Link DP5: DP-5	Inflow=6.45 cfs 0.549 af Primary=6.45 cfs 0.549 af
Link DP6: DP-6	Inflow=5.43 cfs 0.423 af Primary=5.43 cfs 0.423 af
<p>Total Runoff Area = 35.509 ac Runoff Volume = 9.586 af Average Runoff Depth = 3.24" 94.93% Pervious = 33.708 ac 5.07% Impervious = 1.801 ac</p>	

Summary for Subcatchment EXDA1ND: EXDA-1

Runoff = 28.81 cfs @ 12.83 hrs, Volume= 5.204 af, Depth> 3.20"

Runoff by SCS TR-20 method, UH=SCS, Weighted-CN, Time Span= 0.00-24.00 hrs, dt= 0.05 hrs
 Type III 24-hr 50-Year Rainfall=6.30"

Area (sf)	CN	Description
635,511	70	Woods, Good, HSG C
148,147	74	Pasture/grassland/range, Good, HSG C
18,170	71	Meadow, non-grazed, HSG C
49,112	98	Impervious, HSG C
850,940	72	Weighted Average
801,828		94.23% Pervious Area
49,112		5.77% Impervious Area

Tc (min)	Length (feet)	Slope (ft/ft)	Velocity (ft/sec)	Capacity (cfs)	Description
37.0	250	0.0320	0.11		Sheet Flow, Woods: Light underbrush n= 0.400 P2= 3.20"
23.0	1,450	0.0440	1.05		Shallow Concentrated Flow, Woodland Kv= 5.0 fps
1.0	525	0.0570	8.87	53.22	Channel Flow, Area= 6.0 sf Perim= 6.0' r= 1.00' n= 0.040 Earth, cobble bottom, clean sides
61.0	2,225	Total			

Subcatchment EXDA1ND: EXDA-1

Hydrograph

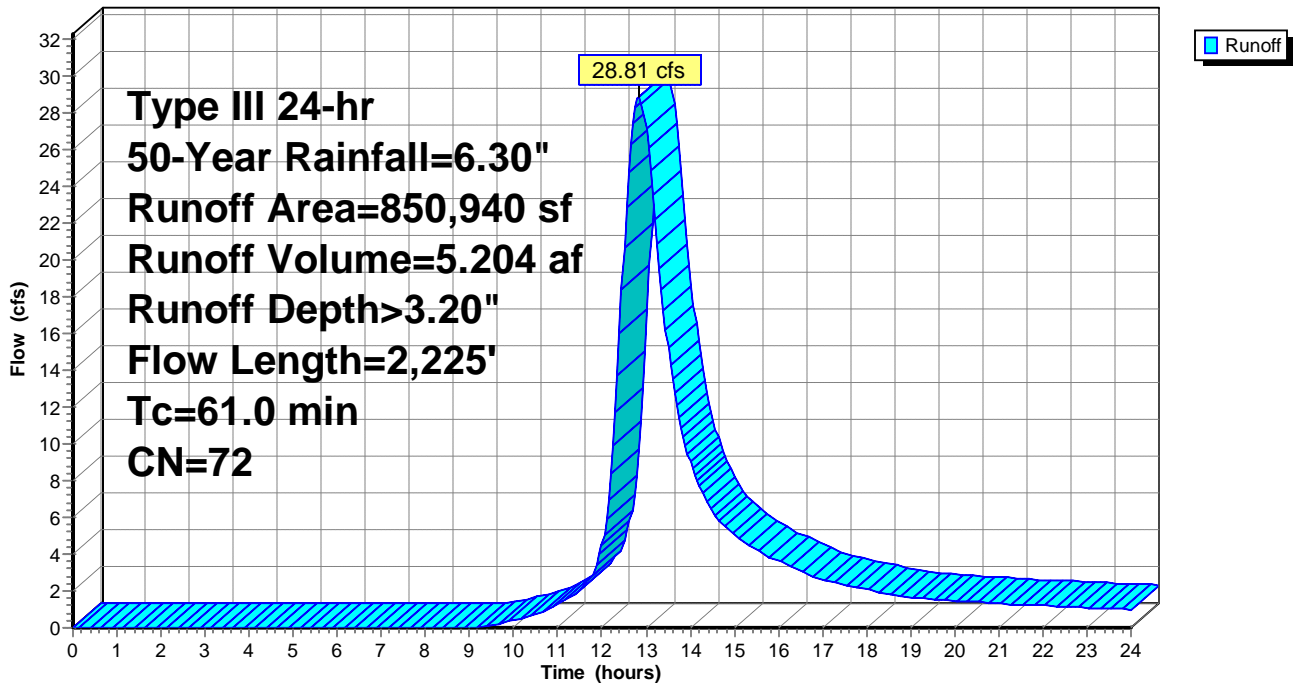

Summary for Subcatchment EXDA2AND: EXDA-2A

Runoff = 5.90 cfs @ 12.40 hrs, Volume= 0.723 af, Depth> 3.22"

Runoff by SCS TR-20 method, UH=SCS, Weighted-CN, Time Span= 0.00-24.00 hrs, dt= 0.05 hrs
 Type III 24-hr 50-Year Rainfall=6.30"

Area (sf)	CN	Description
60,051	70	Woods, Good, HSG C
57,315	74	Pasture/grassland/range, Good, HSG C
117,366	72	Weighted Average
117,366		100.00% Pervious Area

Tc (min)	Length (feet)	Slope (ft/ft)	Velocity (ft/sec)	Capacity (cfs)	Description
27.1	250	0.0700	0.15		Sheet Flow, Woods: Light underbrush n= 0.400 P2= 3.20"
1.4	200	0.2150	2.32		Shallow Concentrated Flow, Woodland Kv= 5.0 fps
28.5	450	Total			

Subcatchment EXDA2AND: EXDA-2A

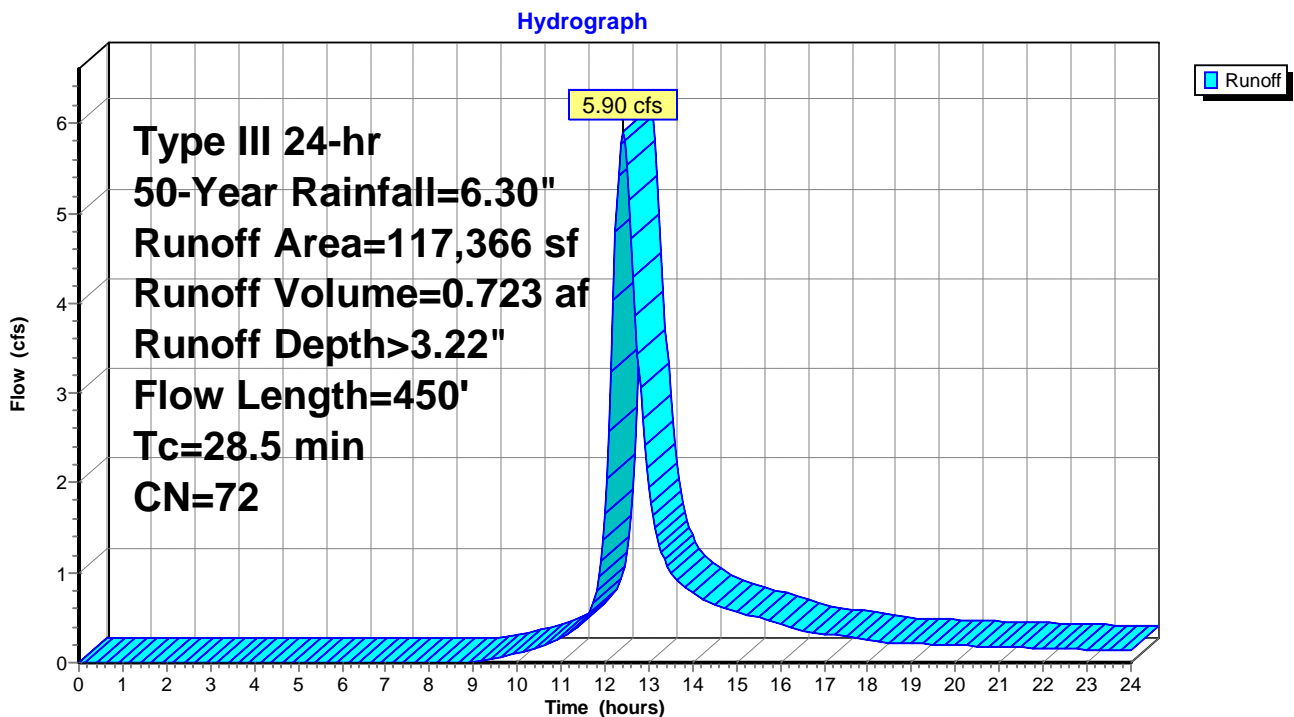

Summary for Subcatchment EXDA2BND: EXDA-2B

Runoff = 6.77 cfs @ 12.65 hrs, Volume= 1.057 af, Depth> 3.01"

Runoff by SCS TR-20 method, UH=SCS, Weighted-CN, Time Span= 0.00-24.00 hrs, dt= 0.05 hrs
 Type III 24-hr 50-Year Rainfall=6.30"

Area (sf)	CN	Description
179,894	70	Woods, Good, HSG C
3,377	74	Pasture/grassland/range, Good, HSG C
183,271	70	Weighted Average
183,271		100.00% Pervious Area

Tc (min)	Length (feet)	Slope (ft/ft)	Velocity (ft/sec)	Capacity (cfs)	Description
36.1	250	0.0340	0.12		Sheet Flow, Woods: Light underbrush n= 0.400 P2= 3.20"
10.6	800	0.0637	1.26		Shallow Concentrated Flow, Woodland Kv= 5.0 fps
46.7	1,050	Total			

Subcatchment EXDA2BND: EXDA-2B

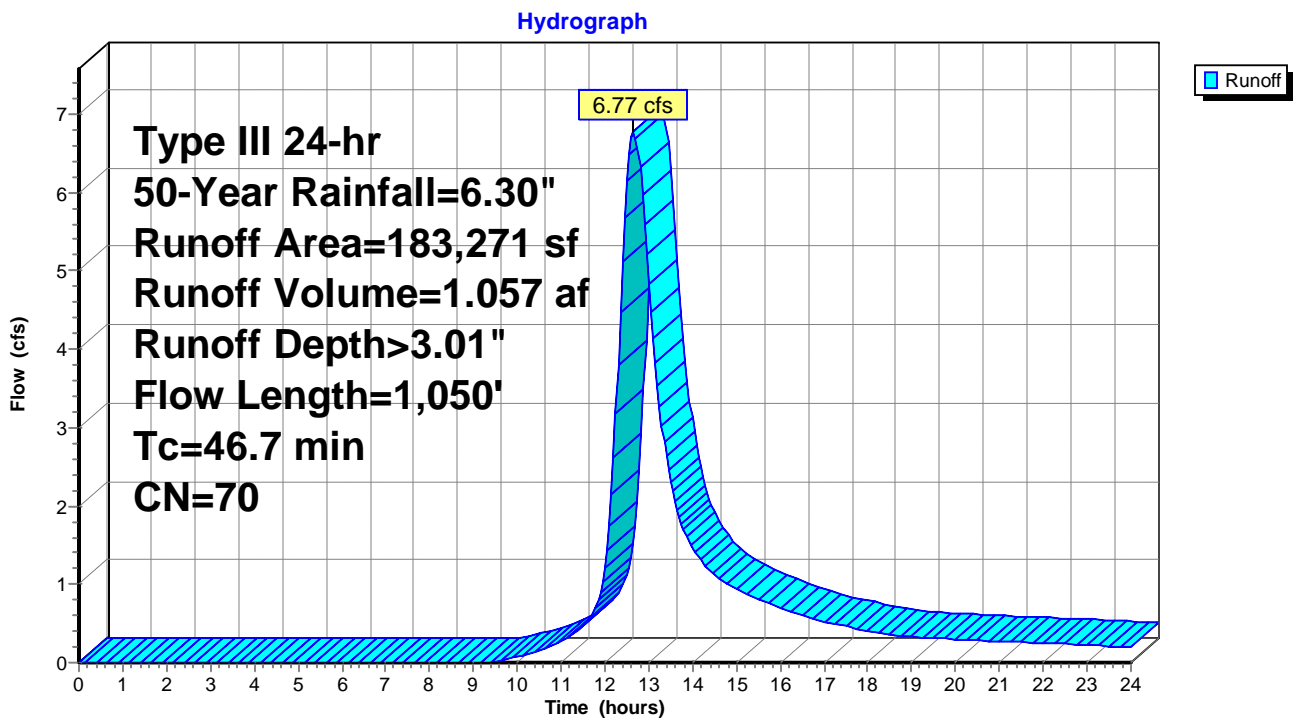

Summary for Subcatchment EXDA3ND: EXDA-3

Runoff = 10.30 cfs @ 12.48 hrs, Volume= 1.376 af, Depth> 3.32"

Runoff by SCS TR-20 method, UH=SCS, Weighted-CN, Time Span= 0.00-24.00 hrs, dt= 0.05 hrs
 Type III 24-hr 50-Year Rainfall=6.30"

Area (sf)	CN	Description
56,418	70	Woods, Good, HSG C
132,061	71	Meadow, non-grazed, HSG C
11,996	74	Pasture/grassland/range, Good, HSG C
16,497	98	Impervious, HSG C
216,972	73	Weighted Average
200,475		92.40% Pervious Area
16,497		7.60% Impervious Area

Tc (min)	Length (feet)	Slope (ft/ft)	Velocity (ft/sec)	Capacity (cfs)	Description
30.5	250	0.0520	0.14		Sheet Flow, Woods: Light underbrush n= 0.400 P2= 3.20"
4.0	360	0.0889	1.49		Shallow Concentrated Flow, Woodland Kv= 5.0 fps

34.5 610 Total

Subcatchment EXDA3ND: EXDA-3

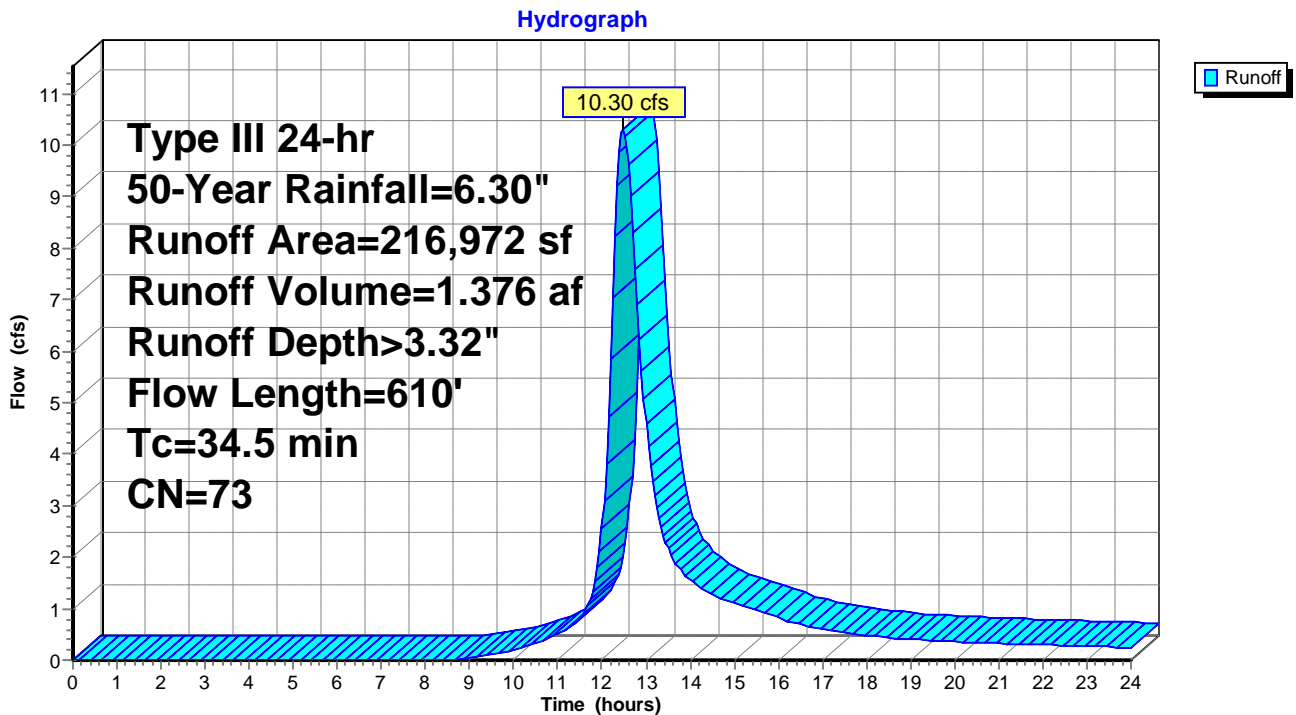

Summary for Subcatchment EXDA4ND: EXDA-4

Runoff = 2.84 cfs @ 12.18 hrs, Volume= 0.255 af, Depth> 3.43"

Runoff by SCS TR-20 method, UH=SCS, Weighted-CN, Time Span= 0.00-24.00 hrs, dt= 0.05 hrs
 Type III 24-hr 50-Year Rainfall=6.30"

Area (sf)	CN	Description
21,726	74	Pasture/grassland/range, Good, HSG C
15,178	71	Meadow, non-grazed, HSG C
* 1,997	98	Impervious
38,901	74	Weighted Average
36,904		94.87% Pervious Area
1,997		5.13% Impervious Area

Tc (min)	Length (feet)	Slope (ft/ft)	Velocity (ft/sec)	Capacity (cfs)	Description
11.8	200	0.0500	0.28		Sheet Flow, Grass: Short n= 0.150 P2= 3.20"
1.2	200	0.1500	2.71		Shallow Concentrated Flow, Short Grass Pasture Kv= 7.0 fps
13.0	400	Total			

Subcatchment EXDA4ND: EXDA-4

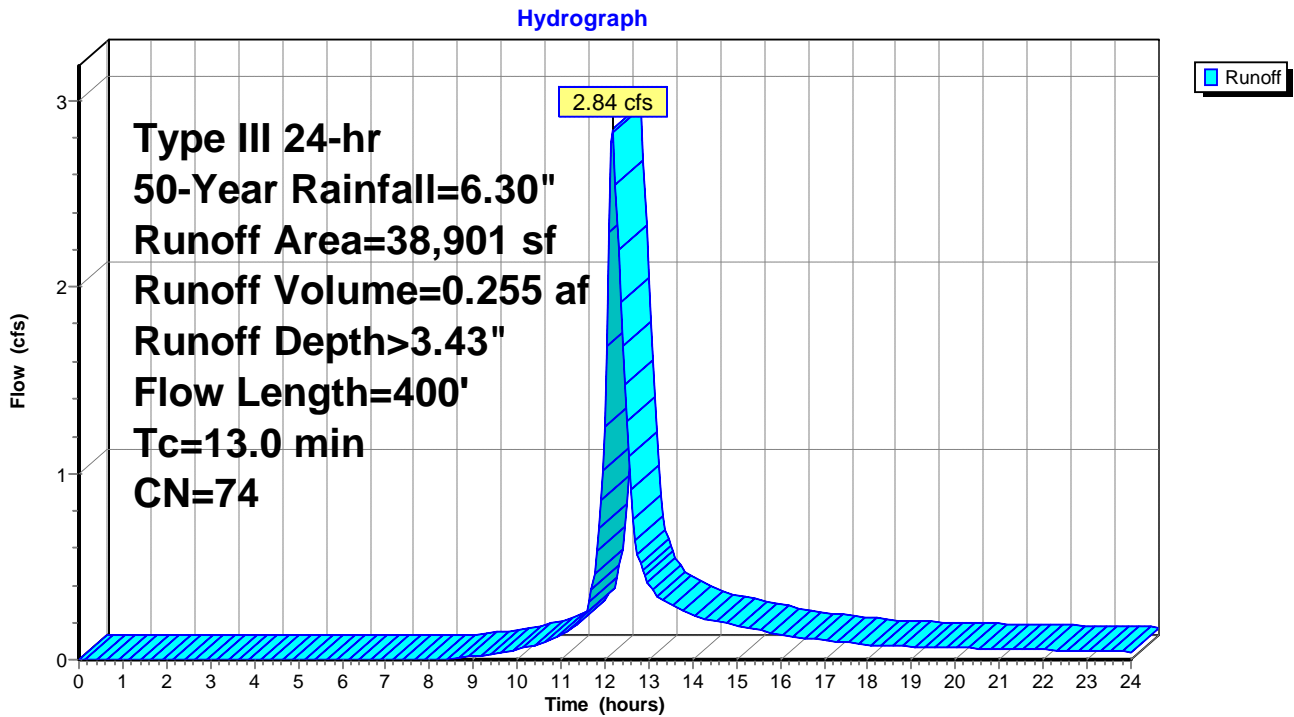

Summary for Subcatchment EXDA5ND: EXDA-5

Runoff = 6.45 cfs @ 12.16 hrs, Volume= 0.549 af, Depth> 3.74"

Runoff by SCS TR-20 method, UH=SCS, Weighted-CN, Time Span= 0.00-24.00 hrs, dt= 0.05 hrs
 Type III 24-hr 50-Year Rainfall=6.30"

Area (sf)	CN	Description
9,039	98	Impervious, HSG C
67,792	74	Pasture/grassland/range, Good, HSG C
76,831	77	Weighted Average
67,792		88.24% Pervious Area
9,039		11.76% Impervious Area

Tc (min)	Length (feet)	Slope (ft/ft)	Velocity (ft/sec)	Capacity (cfs)	Description
10.3	150	0.0400	0.24		Sheet Flow, Grass: Short n= 0.150 P2= 3.20"
1.0	350	0.1350	5.92		Shallow Concentrated Flow, Unpaved Kv= 16.1 fps
11.3	500	Total			

Subcatchment EXDA5ND: EXDA-5

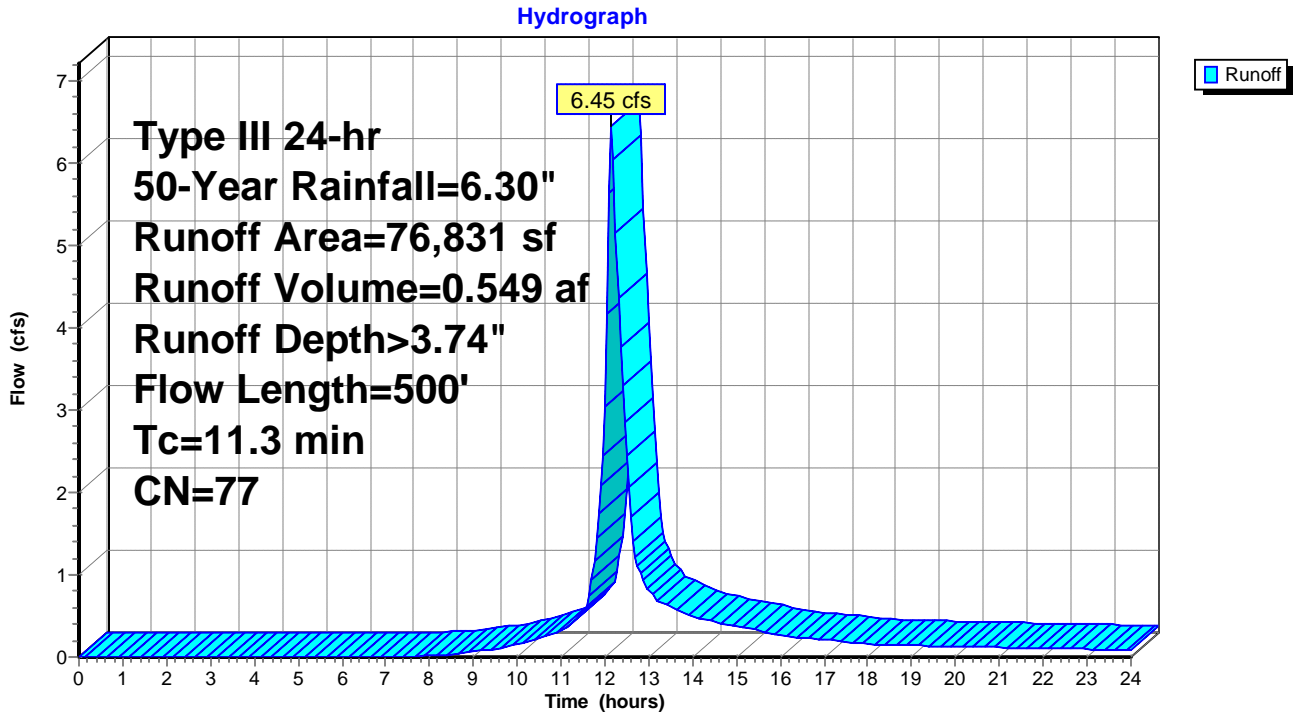

Summary for Subcatchment EXDA6ND: EXDA-6

Runoff = 5.43 cfs @ 12.12 hrs, Volume= 0.423 af, Depth> 3.53"

Runoff by SCS TR-20 method, UH=SCS, Weighted-CN, Time Span= 0.00-24.00 hrs, dt= 0.05 hrs
 Type III 24-hr 50-Year Rainfall=6.30"

Area (sf)	CN	Description
60,704	74	Pasture/grassland/range, Good, HSG C
1,796	98	Impervious, HSG C
62,500	75	Weighted Average
60,704		97.13% Pervious Area
1,796		2.87% Impervious Area

Tc (min)	Length (feet)	Slope (ft/ft)	Velocity (ft/sec)	Capacity (cfs)	Description
7.7	100	0.0360	0.22		Sheet Flow, Grass: Short n= 0.150 P2= 3.20"
0.6	250	0.2050	7.29		Shallow Concentrated Flow, Unpaved Kv= 16.1 fps
8.3	350	Total			

Subcatchment EXDA6ND: EXDA-6

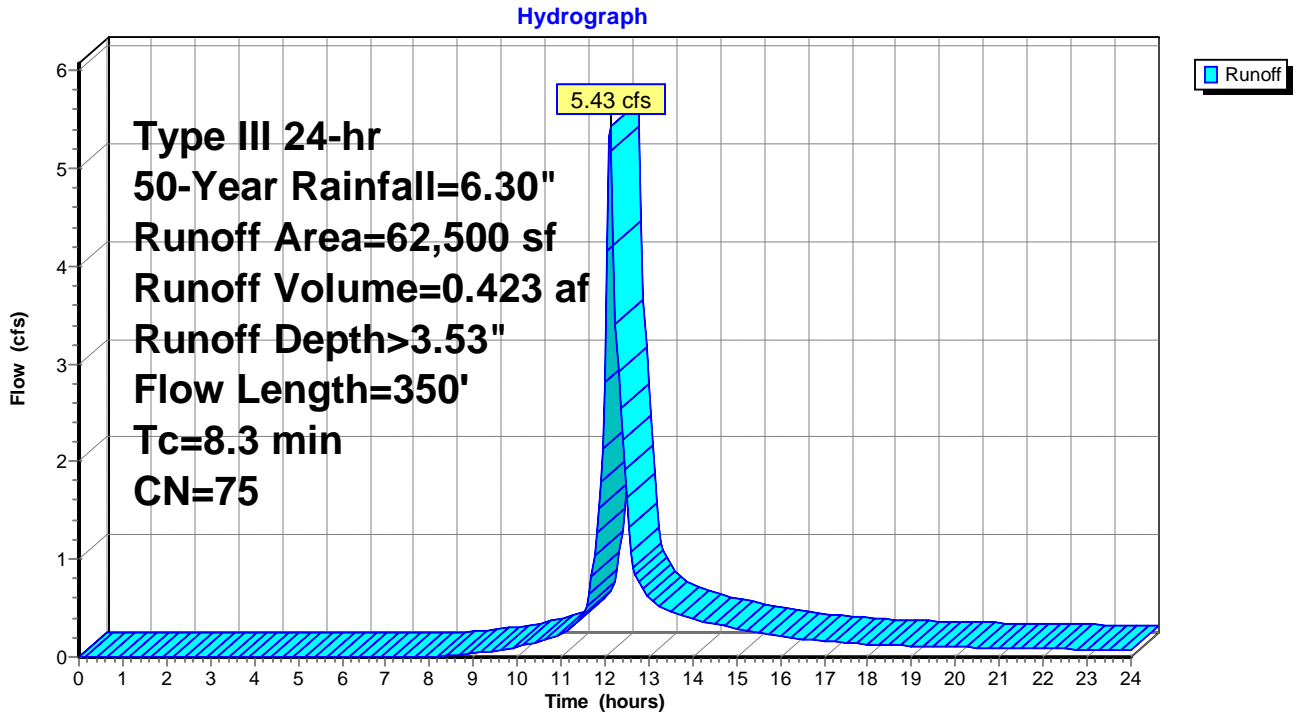

Summary for Link DP1: DP-1

Inflow Area = 19.535 ac, 5.77% Impervious, Inflow Depth > 3.20" for 50-Year event
Inflow = 28.81 cfs @ 12.83 hrs, Volume= 5.204 af
Primary = 28.81 cfs @ 12.83 hrs, Volume= 5.204 af, Atten= 0%, Lag= 0.0 min

Primary outflow = Inflow, Time Span= 0.00-24.00 hrs, dt= 0.05 hrs

Link DP1: DP-1

Hydrograph

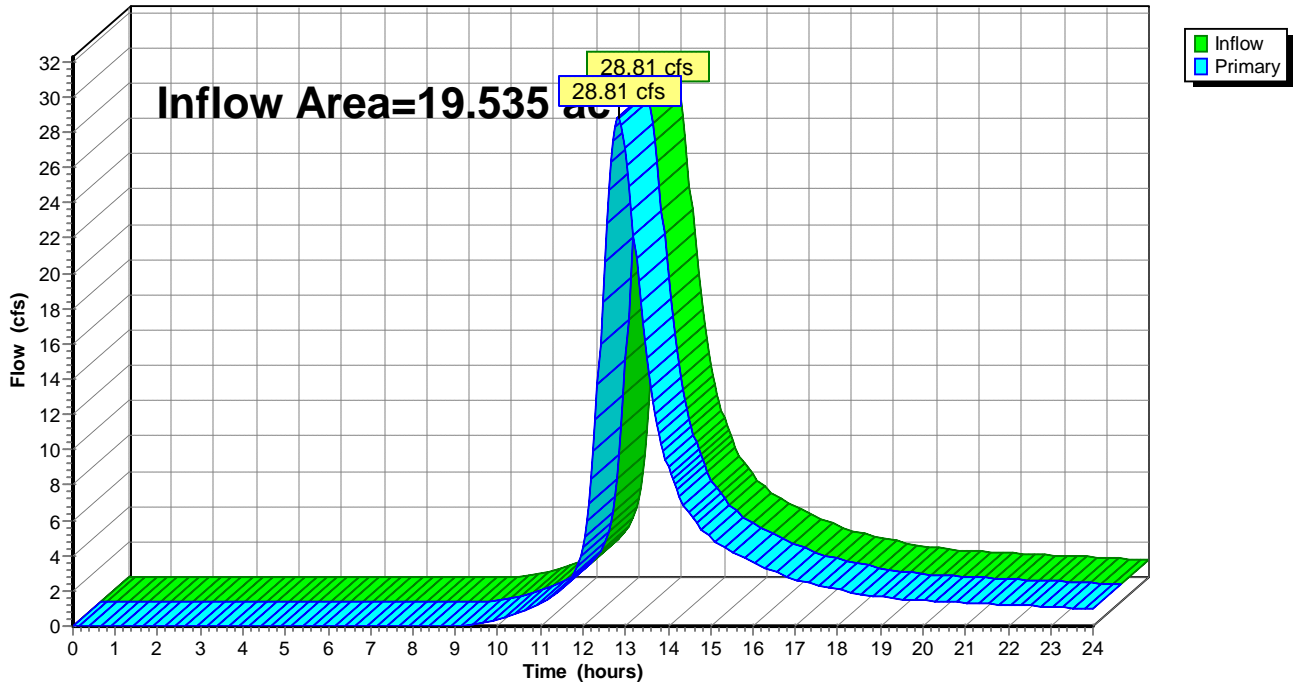

Summary for Link DP2A: DP-2A

Inflow Area = 2.694 ac, 0.00% Impervious, Inflow Depth > 3.22" for 50-Year event
Inflow = 5.90 cfs @ 12.40 hrs, Volume= 0.723 af
Primary = 5.90 cfs @ 12.40 hrs, Volume= 0.723 af, Atten= 0%, Lag= 0.0 min

Primary outflow = Inflow, Time Span= 0.00-24.00 hrs, dt= 0.05 hrs

Link DP2A: DP-2A

Hydrograph

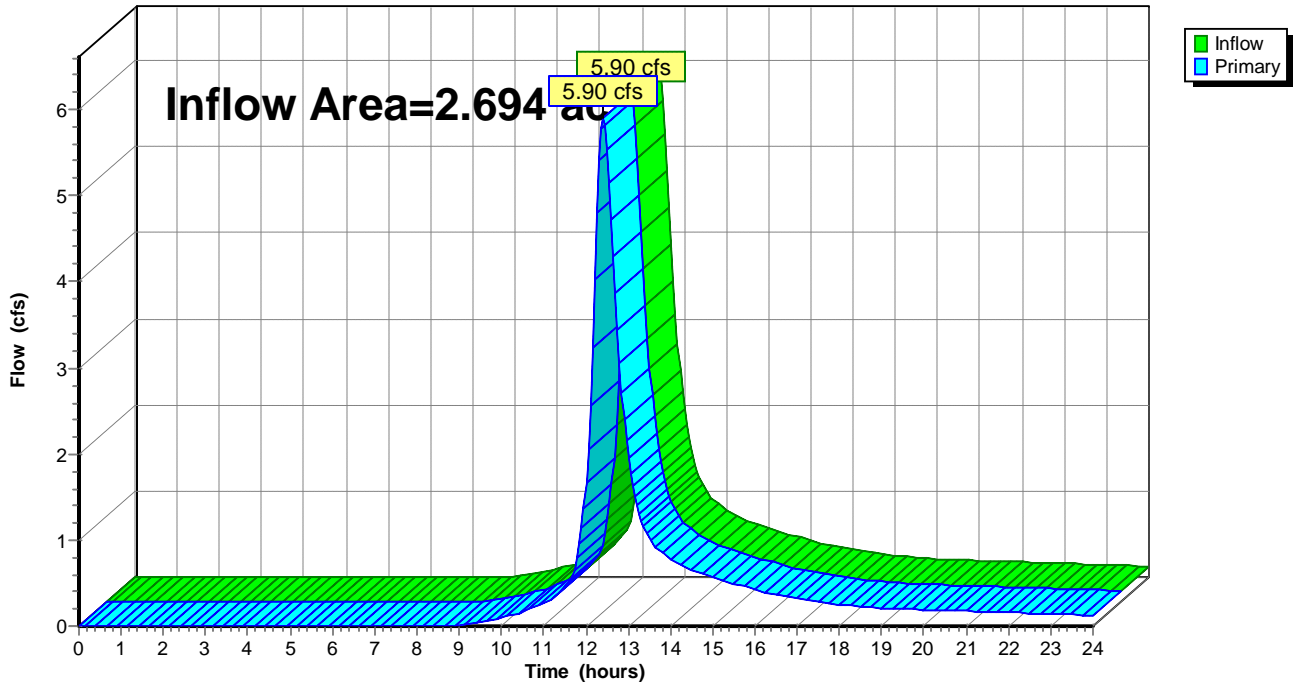

Summary for Link DP2B: DP-2B

Inflow Area = 4.207 ac, 0.00% Impervious, Inflow Depth > 3.01" for 50-Year event
Inflow = 6.77 cfs @ 12.65 hrs, Volume= 1.057 af
Primary = 6.77 cfs @ 12.65 hrs, Volume= 1.057 af, Atten= 0%, Lag= 0.0 min

Primary outflow = Inflow, Time Span= 0.00-24.00 hrs, dt= 0.05 hrs

Link DP2B: DP-2B

Hydrograph

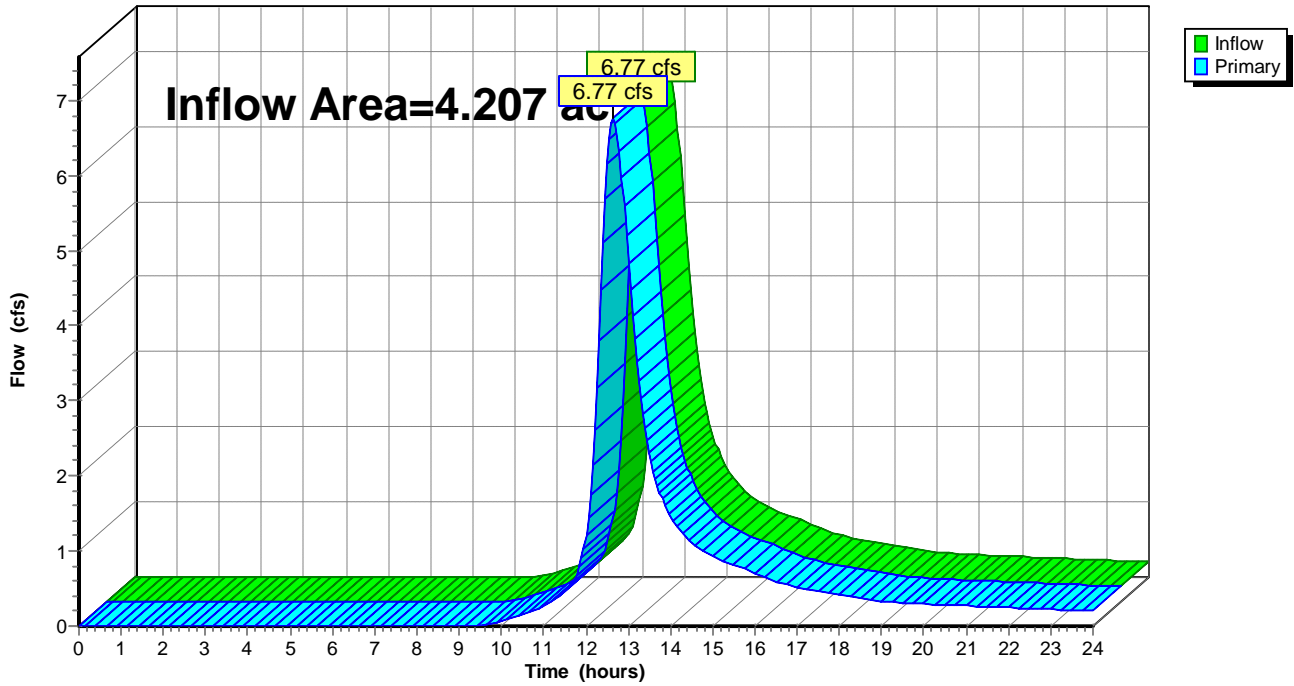

Summary for Link DP3: DP-3

Inflow Area = 4.981 ac, 7.60% Impervious, Inflow Depth > 3.32" for 50-Year event
Inflow = 10.30 cfs @ 12.48 hrs, Volume= 1.376 af
Primary = 10.30 cfs @ 12.48 hrs, Volume= 1.376 af, Atten= 0%, Lag= 0.0 min

Primary outflow = Inflow, Time Span= 0.00-24.00 hrs, dt= 0.05 hrs

Link DP3: DP-3

Hydrograph

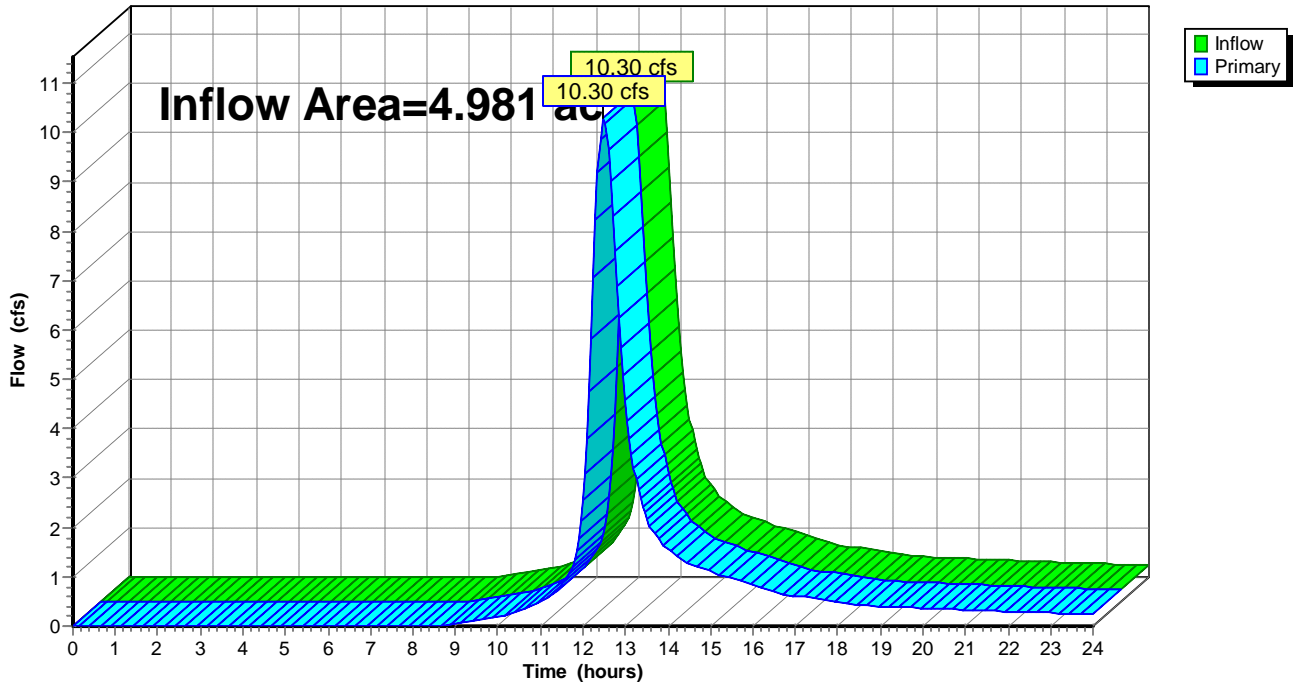

Summary for Link DP4: DP-4

Inflow Area = 0.893 ac, 5.13% Impervious, Inflow Depth > 3.43" for 50-Year event
Inflow = 2.84 cfs @ 12.18 hrs, Volume= 0.255 af
Primary = 2.84 cfs @ 12.18 hrs, Volume= 0.255 af, Atten= 0%, Lag= 0.0 min

Primary outflow = Inflow, Time Span= 0.00-24.00 hrs, dt= 0.05 hrs

Link DP4: DP-4

Hydrograph

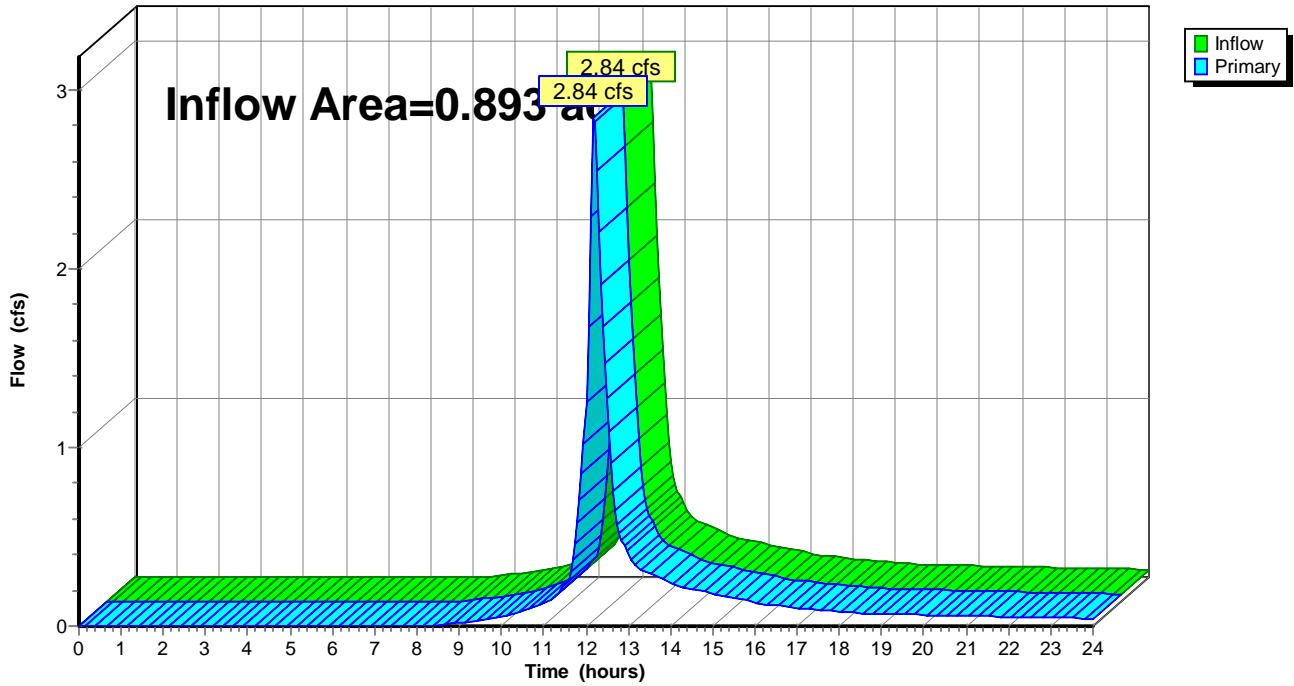

Summary for Link DP5: DP-5

Inflow Area = 1.764 ac, 11.76% Impervious, Inflow Depth > 3.74" for 50-Year event
Inflow = 6.45 cfs @ 12.16 hrs, Volume= 0.549 af
Primary = 6.45 cfs @ 12.16 hrs, Volume= 0.549 af, Atten= 0%, Lag= 0.0 min

Primary outflow = Inflow, Time Span= 0.00-24.00 hrs, dt= 0.05 hrs

Link DP5: DP-5

Hydrograph

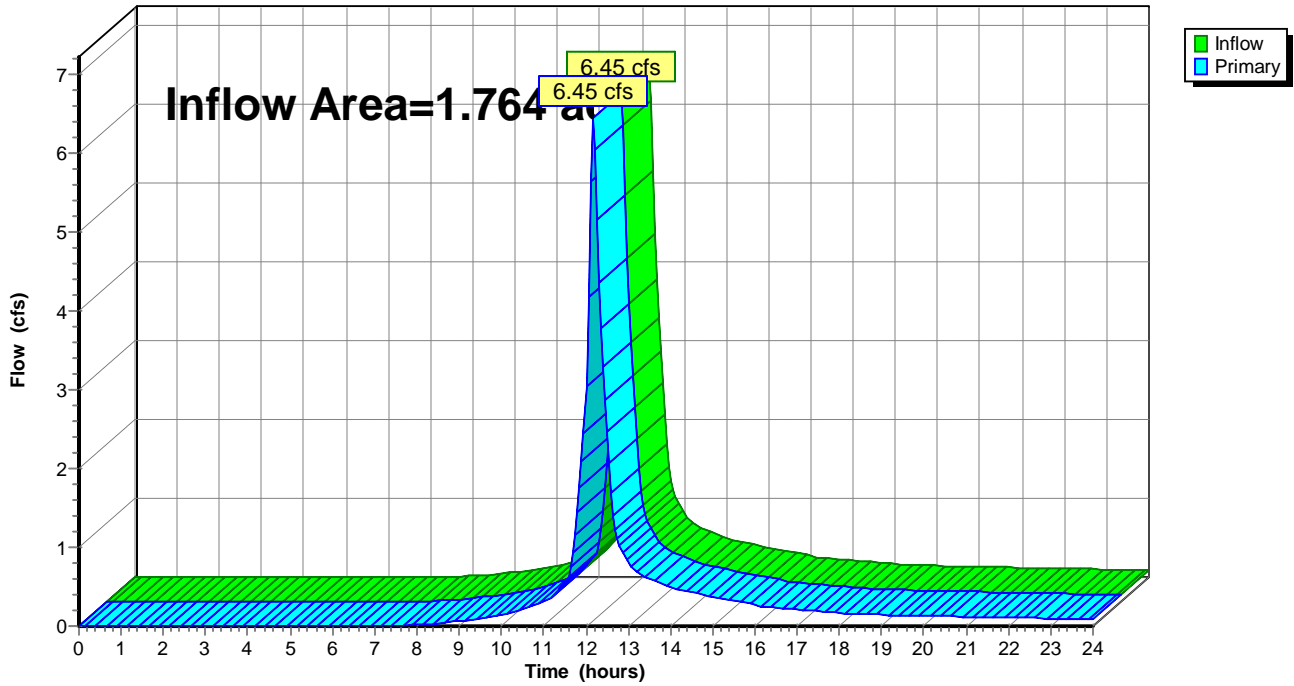

Summary for Link DP6: DP-6

Inflow Area = 1.435 ac, 2.87% Impervious, Inflow Depth > 3.53" for 50-Year event
Inflow = 5.43 cfs @ 12.12 hrs, Volume= 0.423 af
Primary = 5.43 cfs @ 12.12 hrs, Volume= 0.423 af, Atten= 0%, Lag= 0.0 min

Primary outflow = Inflow, Time Span= 0.00-24.00 hrs, dt= 0.05 hrs

Link DP6: DP-6

Hydrograph

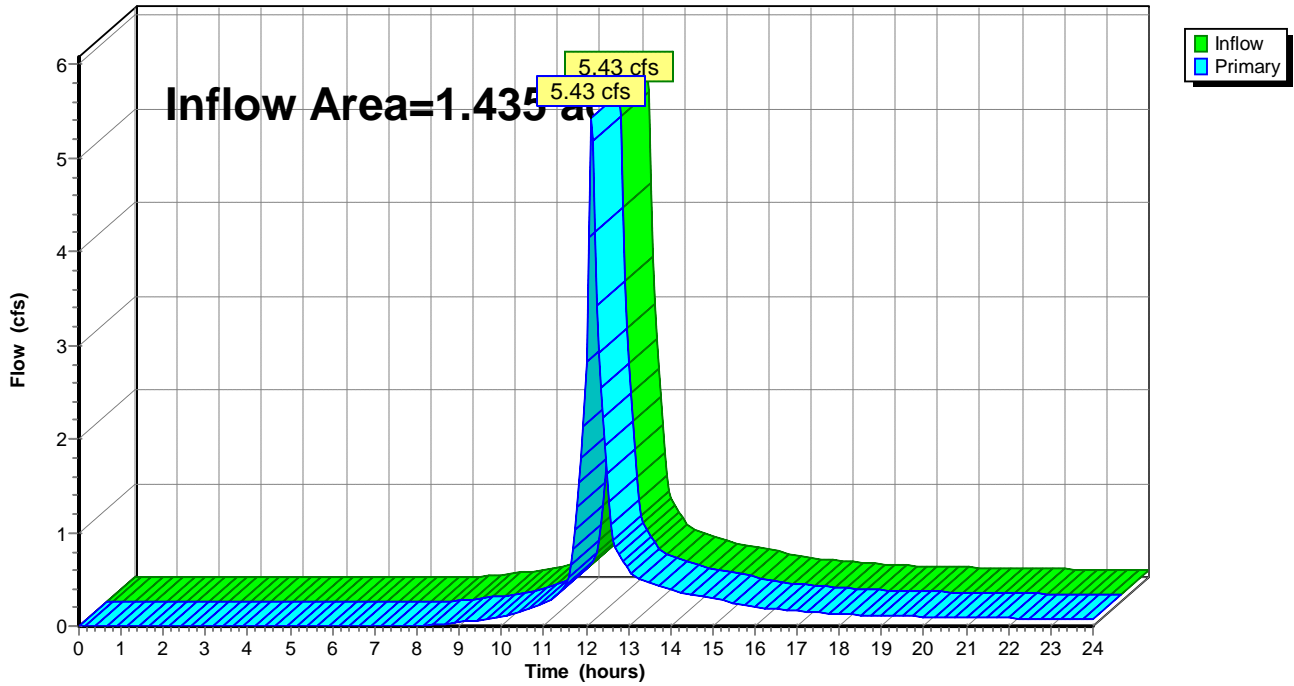

Time span=0.00-24.00 hrs, dt=0.05 hrs, 481 points
 Runoff by SCS TR-20 method, UH=SCS, Weighted-CN
 Reach routing by Stor-Ind+Trans method - Pond routing by Stor-Ind method

Subcatchment EXDA1ND: EXDA-1	Runoff Area=850,940 sf 5.77% Impervious Runoff Depth>3.86" Flow Length=2,225' Tc=61.0 min CN=72 Runoff=34.94 cfs 6.289 af
Subcatchment EXDA2AND: EXDA-2A	Runoff Area=117,366 sf 0.00% Impervious Runoff Depth>3.89" Flow Length=450' Tc=28.5 min CN=72 Runoff=7.15 cfs 0.874 af
Subcatchment EXDA2BND: EXDA-2B	Runoff Area=183,271 sf 0.00% Impervious Runoff Depth>3.66" Flow Length=1,050' Tc=46.7 min CN=70 Runoff=8.26 cfs 1.285 af
Subcatchment EXDA3ND: EXDA-3	Runoff Area=216,972 sf 7.60% Impervious Runoff Depth>3.99" Flow Length=610' Tc=34.5 min CN=73 Runoff=12.42 cfs 1.658 af
Subcatchment EXDA4ND: EXDA-4	Runoff Area=38,901 sf 5.13% Impervious Runoff Depth>4.12" Flow Length=400' Tc=13.0 min CN=74 Runoff=3.41 cfs 0.307 af
Subcatchment EXDA5ND: EXDA-5	Runoff Area=76,831 sf 11.76% Impervious Runoff Depth>4.45" Flow Length=500' Tc=11.3 min CN=77 Runoff=7.66 cfs 0.654 af
Subcatchment EXDA6ND: EXDA-6	Runoff Area=62,500 sf 2.87% Impervious Runoff Depth>4.23" Flow Length=350' Tc=8.3 min CN=75 Runoff=6.49 cfs 0.506 af
Link DP1: DP-1	Inflow=34.94 cfs 6.289 af Primary=34.94 cfs 6.289 af
Link DP2A: DP-2A	Inflow=7.15 cfs 0.874 af Primary=7.15 cfs 0.874 af
Link DP2B: DP-2B	Inflow=8.26 cfs 1.285 af Primary=8.26 cfs 1.285 af
Link DP3: DP-3	Inflow=12.42 cfs 1.658 af Primary=12.42 cfs 1.658 af
Link DP4: DP-4	Inflow=3.41 cfs 0.307 af Primary=3.41 cfs 0.307 af
Link DP5: DP-5	Inflow=7.66 cfs 0.654 af Primary=7.66 cfs 0.654 af
Link DP6: DP-6	Inflow=6.49 cfs 0.506 af Primary=6.49 cfs 0.506 af

Total Runoff Area = 35.509 ac Runoff Volume = 11.572 af Average Runoff Depth = 3.91"
 94.93% Pervious = 33.708 ac 5.07% Impervious = 1.801 ac

Summary for Subcatchment EXDA1ND: EXDA-1

Runoff = 34.94 cfs @ 12.82 hrs, Volume= 6.289 af, Depth> 3.86"

Runoff by SCS TR-20 method, UH=SCS, Weighted-CN, Time Span= 0.00-24.00 hrs, dt= 0.05 hrs
Type III 24-hr 100-Year Rainfall=7.10"

Area (sf)	CN	Description
635,511	70	Woods, Good, HSG C
148,147	74	Pasture/grassland/range, Good, HSG C
18,170	71	Meadow, non-grazed, HSG C
49,112	98	Impervious, HSG C
850,940	72	Weighted Average
801,828		94.23% Pervious Area
49,112		5.77% Impervious Area

Tc (min)	Length (feet)	Slope (ft/ft)	Velocity (ft/sec)	Capacity (cfs)	Description
37.0	250	0.0320	0.11		Sheet Flow, Woods: Light underbrush n= 0.400 P2= 3.20"
23.0	1,450	0.0440	1.05		Shallow Concentrated Flow, Woodland Kv= 5.0 fps
1.0	525	0.0570	8.87	53.22	Channel Flow, Area= 6.0 sf Perim= 6.0' r= 1.00' n= 0.040 Earth, cobble bottom, clean sides
61.0	2,225	Total			

Subcatchment EXDA1ND: EXDA-1

Hydrograph

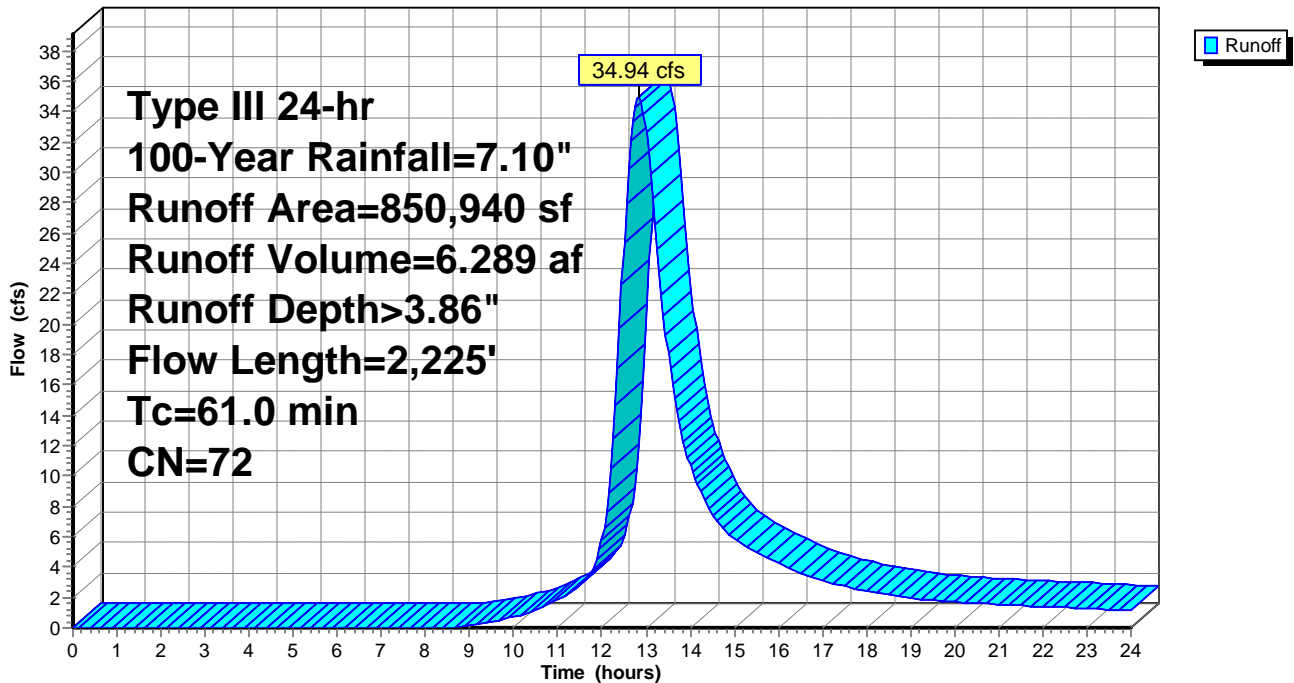

Summary for Subcatchment EXDA2AND: EXDA-2A

Runoff = 7.15 cfs @ 12.40 hrs, Volume= 0.874 af, Depth> 3.89"

Runoff by SCS TR-20 method, UH=SCS, Weighted-CN, Time Span= 0.00-24.00 hrs, dt= 0.05 hrs
 Type III 24-hr 100-Year Rainfall=7.10"

Area (sf)	CN	Description
60,051	70	Woods, Good, HSG C
57,315	74	Pasture/grassland/range, Good, HSG C
117,366	72	Weighted Average
117,366		100.00% Pervious Area

Tc (min)	Length (feet)	Slope (ft/ft)	Velocity (ft/sec)	Capacity (cfs)	Description
27.1	250	0.0700	0.15		Sheet Flow, Woods: Light underbrush n= 0.400 P2= 3.20"
1.4	200	0.2150	2.32		Shallow Concentrated Flow, Woodland Kv= 5.0 fps
28.5	450	Total			

Subcatchment EXDA2AND: EXDA-2A

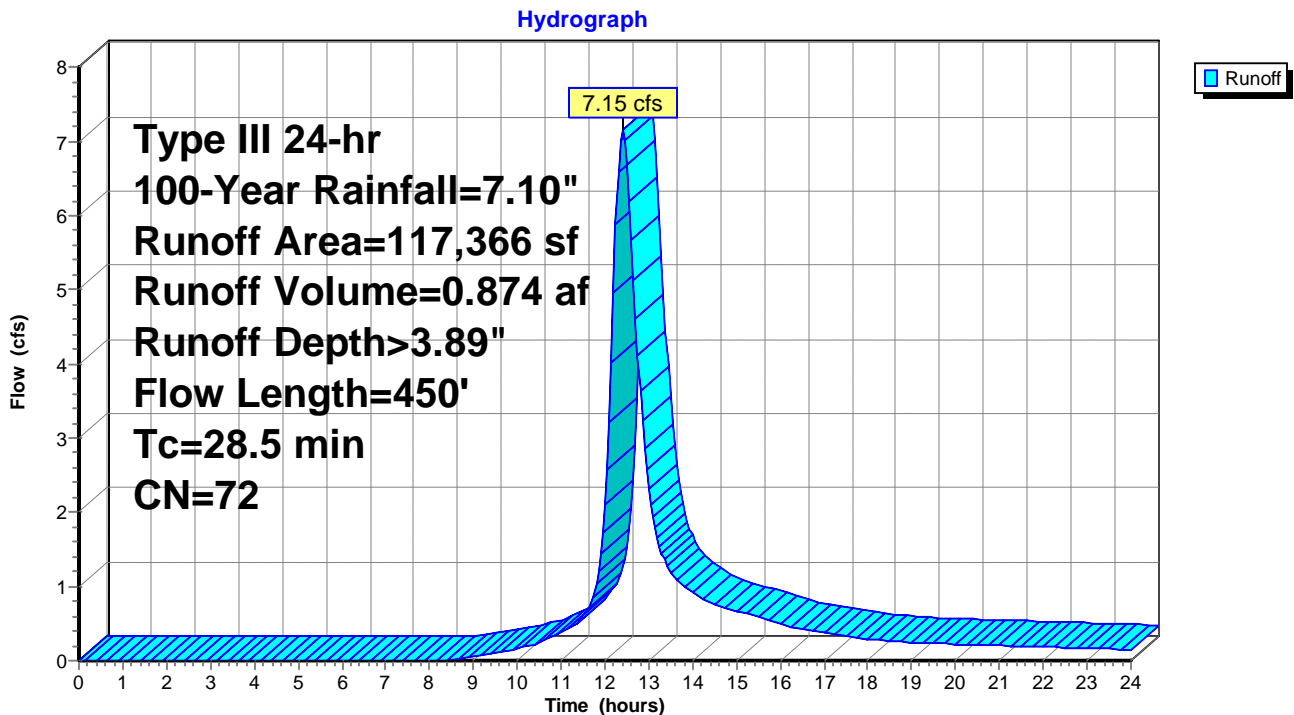

Summary for Subcatchment EXDA2BND: EXDA-2B

Runoff = 8.26 cfs @ 12.65 hrs, Volume= 1.285 af, Depth> 3.66"

Runoff by SCS TR-20 method, UH=SCS, Weighted-CN, Time Span= 0.00-24.00 hrs, dt= 0.05 hrs
 Type III 24-hr 100-Year Rainfall=7.10"

Area (sf)	CN	Description
179,894	70	Woods, Good, HSG C
3,377	74	Pasture/grassland/range, Good, HSG C
183,271	70	Weighted Average
183,271		100.00% Pervious Area

Tc (min)	Length (feet)	Slope (ft/ft)	Velocity (ft/sec)	Capacity (cfs)	Description
36.1	250	0.0340	0.12		Sheet Flow, Woods: Light underbrush n= 0.400 P2= 3.20"
10.6	800	0.0637	1.26		Shallow Concentrated Flow, Woodland Kv= 5.0 fps
46.7	1,050	Total			

Subcatchment EXDA2BND: EXDA-2B

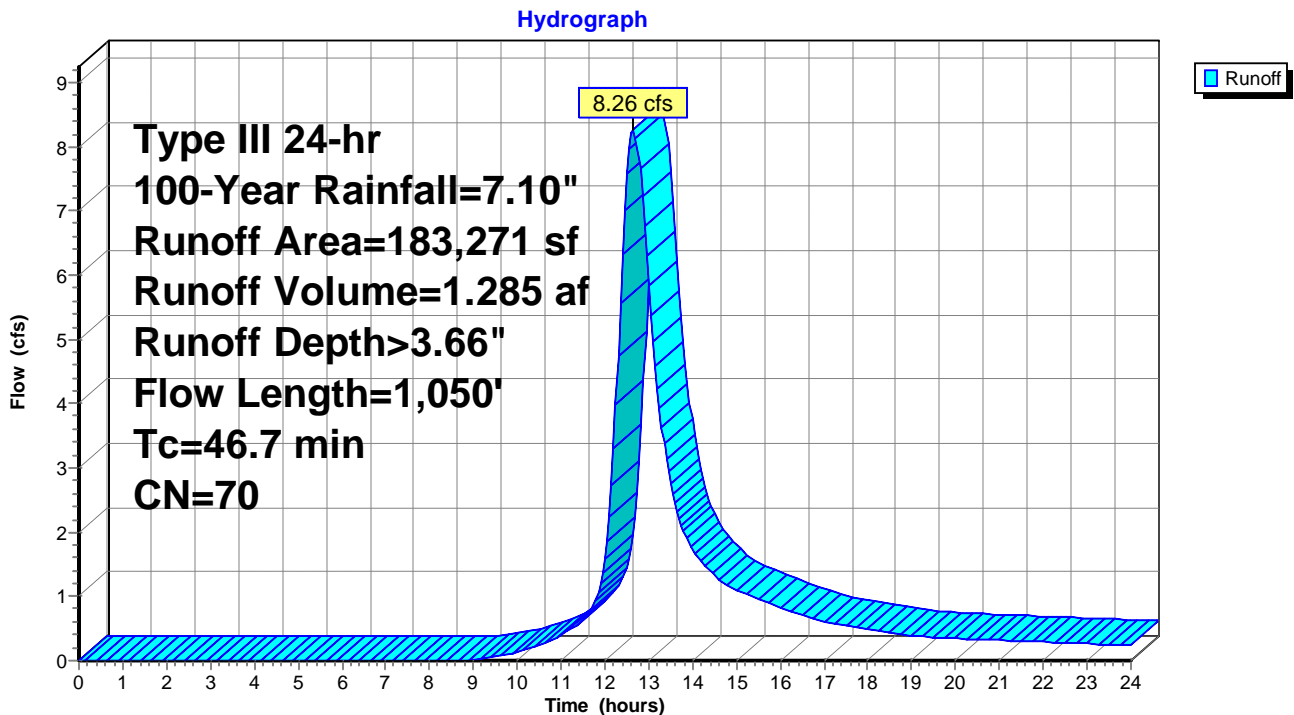

Summary for Subcatchment EXDA3ND: EXDA-3

Runoff = 12.42 cfs @ 12.48 hrs, Volume= 1.658 af, Depth> 3.99"

Runoff by SCS TR-20 method, UH=SCS, Weighted-CN, Time Span= 0.00-24.00 hrs, dt= 0.05 hrs
 Type III 24-hr 100-Year Rainfall=7.10"

Area (sf)	CN	Description
56,418	70	Woods, Good, HSG C
132,061	71	Meadow, non-grazed, HSG C
11,996	74	Pasture/grassland/range, Good, HSG C
16,497	98	Impervious, HSG C
216,972	73	Weighted Average
200,475		92.40% Pervious Area
16,497		7.60% Impervious Area

Tc (min)	Length (feet)	Slope (ft/ft)	Velocity (ft/sec)	Capacity (cfs)	Description
30.5	250	0.0520	0.14		Sheet Flow, Woods: Light underbrush n= 0.400 P2= 3.20"
4.0	360	0.0889	1.49		Shallow Concentrated Flow, Woodland Kv= 5.0 fps
34.5	610	Total			

Subcatchment EXDA3ND: EXDA-3

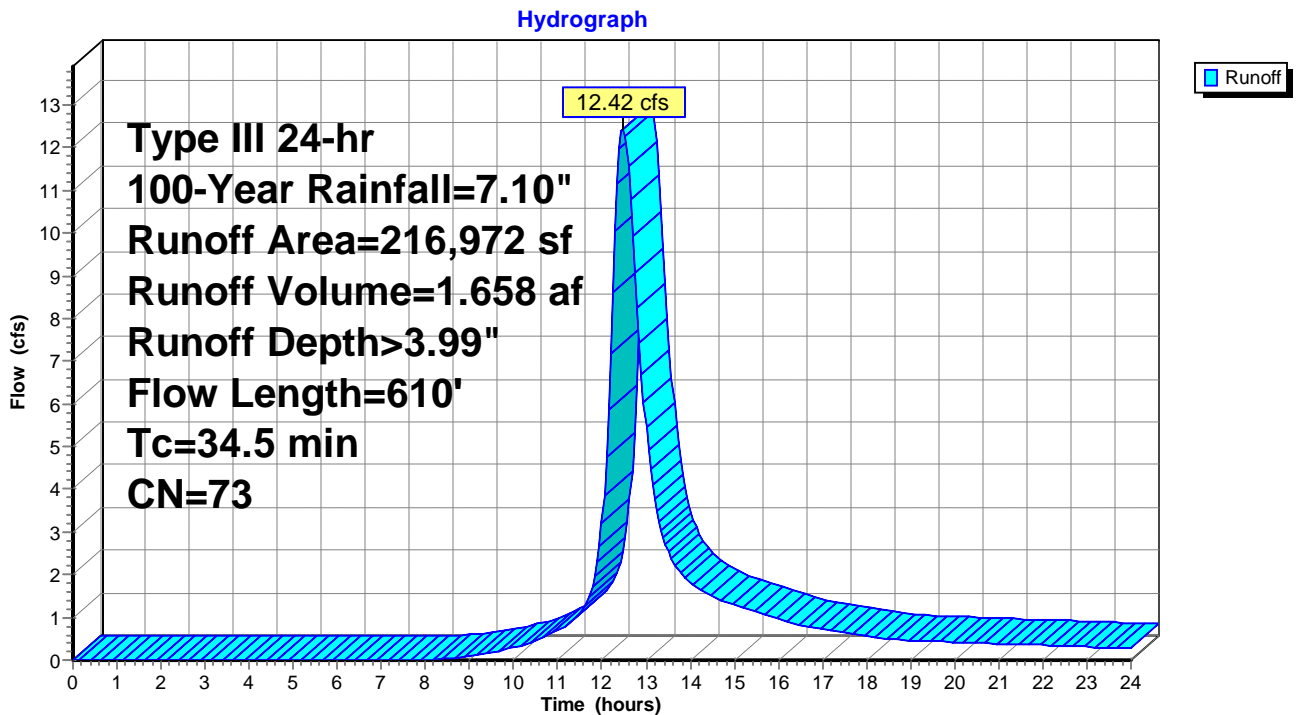

Summary for Subcatchment EXDA4ND: EXDA-4

Runoff = 3.41 cfs @ 12.18 hrs, Volume= 0.307 af, Depth> 4.12"

Runoff by SCS TR-20 method, UH=SCS, Weighted-CN, Time Span= 0.00-24.00 hrs, dt= 0.05 hrs
 Type III 24-hr 100-Year Rainfall=7.10"

Area (sf)	CN	Description
21,726	74	Pasture/grassland/range, Good, HSG C
15,178	71	Meadow, non-grazed, HSG C
* 1,997	98	Impervious
38,901	74	Weighted Average
36,904		94.87% Pervious Area
1,997		5.13% Impervious Area

Tc (min)	Length (feet)	Slope (ft/ft)	Velocity (ft/sec)	Capacity (cfs)	Description
11.8	200	0.0500	0.28		Sheet Flow, Grass: Short n= 0.150 P2= 3.20"
1.2	200	0.1500	2.71		Shallow Concentrated Flow, Short Grass Pasture Kv= 7.0 fps
13.0	400	Total			

Subcatchment EXDA4ND: EXDA-4

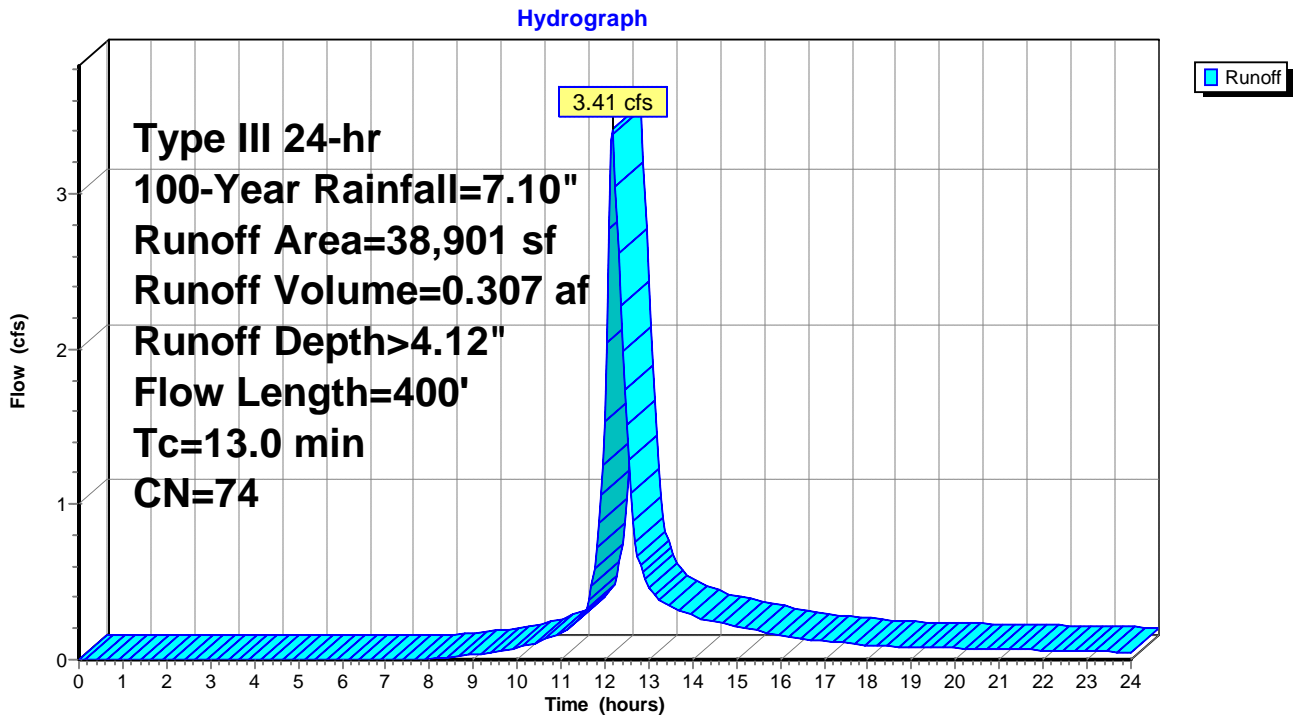

Summary for Subcatchment EXDA5ND: EXDA-5

Runoff = 7.66 cfs @ 12.16 hrs, Volume= 0.654 af, Depth> 4.45"

Runoff by SCS TR-20 method, UH=SCS, Weighted-CN, Time Span= 0.00-24.00 hrs, dt= 0.05 hrs
 Type III 24-hr 100-Year Rainfall=7.10"

Area (sf)	CN	Description
9,039	98	Impervious, HSG C
67,792	74	Pasture/grassland/range, Good, HSG C
76,831	77	Weighted Average
67,792		88.24% Pervious Area
9,039		11.76% Impervious Area

Tc (min)	Length (feet)	Slope (ft/ft)	Velocity (ft/sec)	Capacity (cfs)	Description
10.3	150	0.0400	0.24		Sheet Flow, Grass: Short n= 0.150 P2= 3.20"
1.0	350	0.1350	5.92		Shallow Concentrated Flow, Unpaved Kv= 16.1 fps
11.3	500	Total			

Subcatchment EXDA5ND: EXDA-5

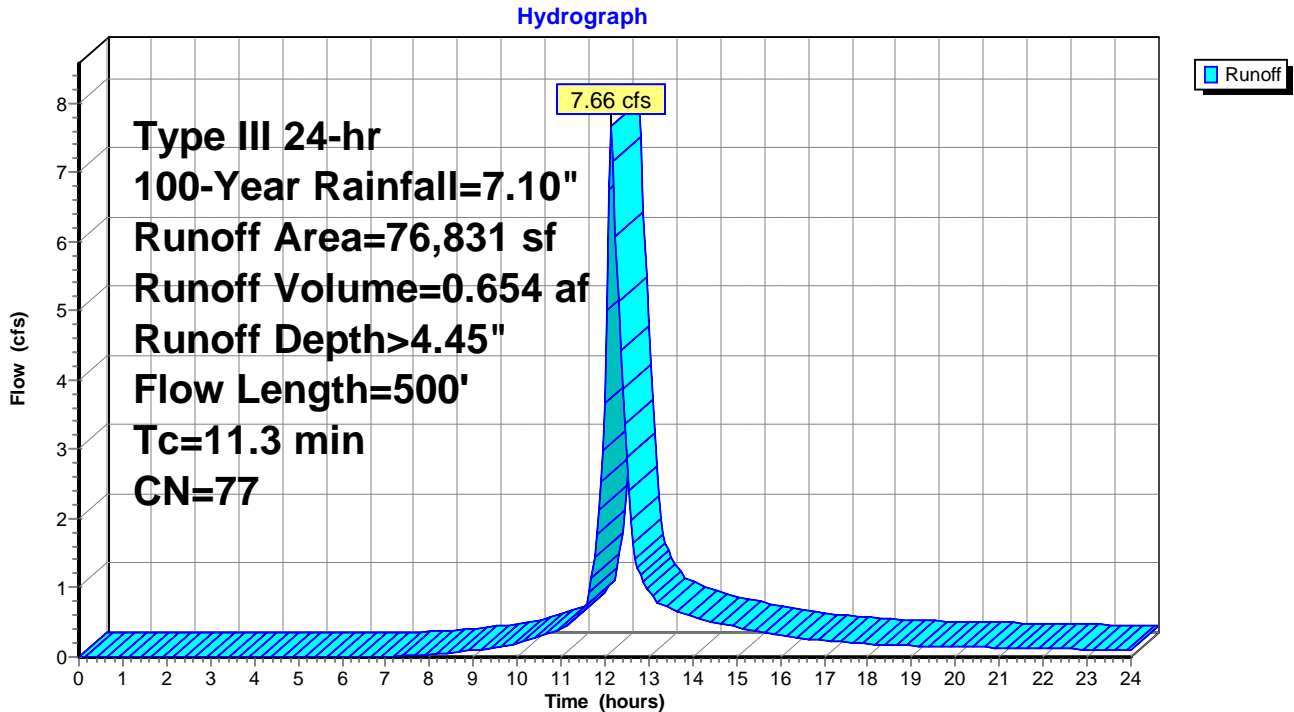

Summary for Subcatchment EXDA6ND: EXDA-6

Runoff = 6.49 cfs @ 12.12 hrs, Volume= 0.506 af, Depth> 4.23"

Runoff by SCS TR-20 method, UH=SCS, Weighted-CN, Time Span= 0.00-24.00 hrs, dt= 0.05 hrs
 Type III 24-hr 100-Year Rainfall=7.10"

Area (sf)	CN	Description
60,704	74	Pasture/grassland/range, Good, HSG C
1,796	98	Impervious, HSG C
62,500	75	Weighted Average
60,704		97.13% Pervious Area
1,796		2.87% Impervious Area

Tc (min)	Length (feet)	Slope (ft/ft)	Velocity (ft/sec)	Capacity (cfs)	Description
7.7	100	0.0360	0.22		Sheet Flow, Grass: Short n= 0.150 P2= 3.20"
0.6	250	0.2050	7.29		Shallow Concentrated Flow, Unpaved Kv= 16.1 fps
8.3	350	Total			

Subcatchment EXDA6ND: EXDA-6

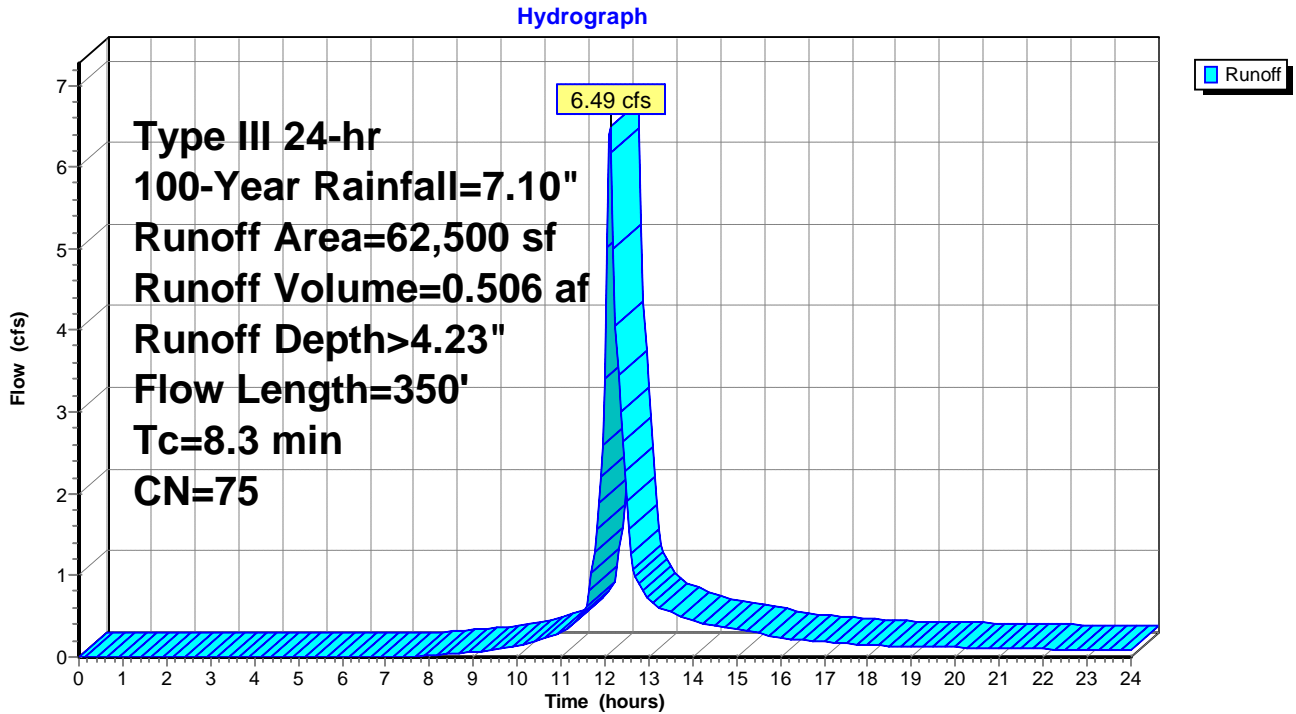

Summary for Link DP1: DP-1

Inflow Area = 19.535 ac, 5.77% Impervious, Inflow Depth > 3.86" for 100-Year event
Inflow = 34.94 cfs @ 12.82 hrs, Volume= 6.289 af
Primary = 34.94 cfs @ 12.82 hrs, Volume= 6.289 af, Atten= 0%, Lag= 0.0 min

Primary outflow = Inflow, Time Span= 0.00-24.00 hrs, dt= 0.05 hrs

Link DP1: DP-1

Hydrograph

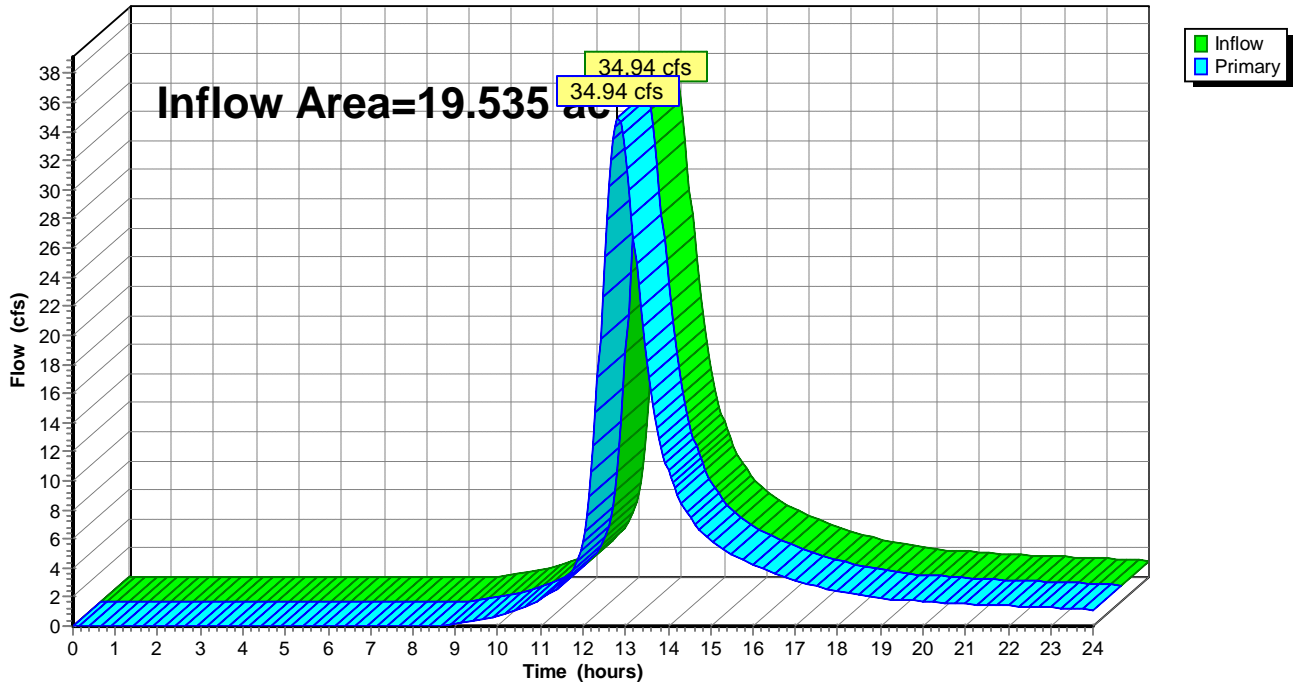

Summary for Link DP2A: DP-2A

Inflow Area = 2.694 ac, 0.00% Impervious, Inflow Depth > 3.89" for 100-Year event
Inflow = 7.15 cfs @ 12.40 hrs, Volume= 0.874 af
Primary = 7.15 cfs @ 12.40 hrs, Volume= 0.874 af, Atten= 0%, Lag= 0.0 min

Primary outflow = Inflow, Time Span= 0.00-24.00 hrs, dt= 0.05 hrs

Link DP2A: DP-2A

Hydrograph

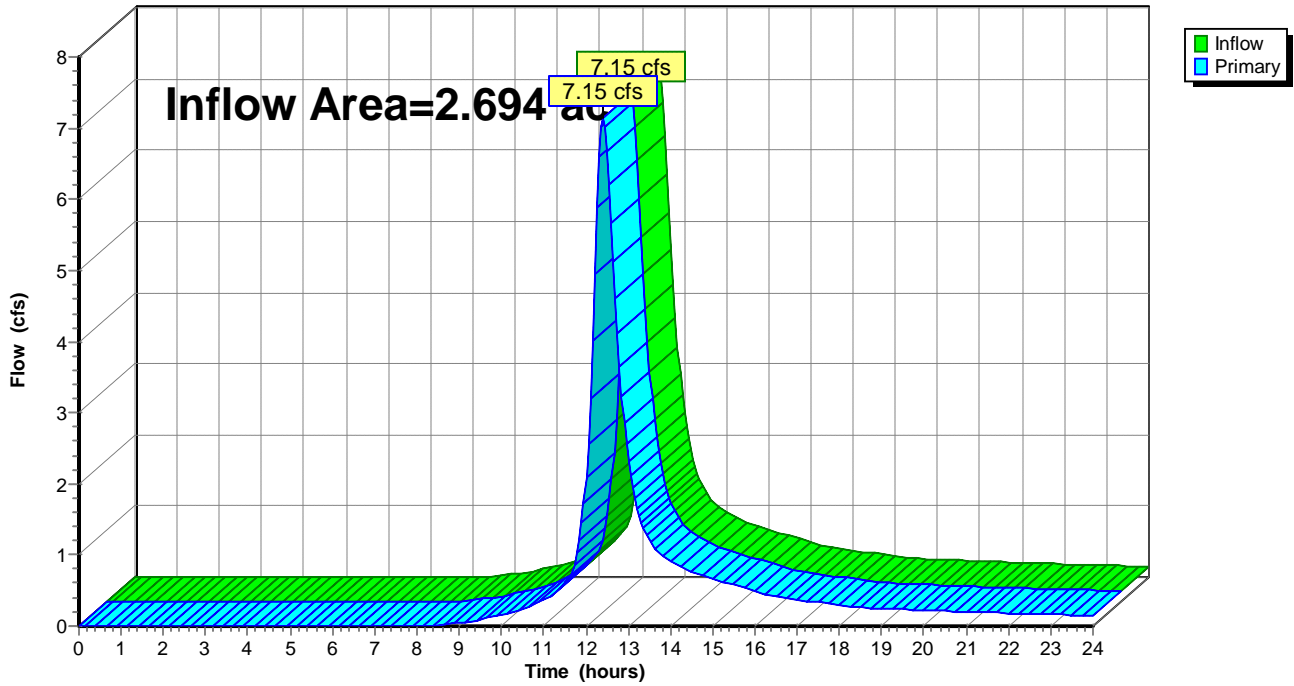

Summary for Link DP2B: DP-2B

Inflow Area = 4.207 ac, 0.00% Impervious, Inflow Depth > 3.66" for 100-Year event
Inflow = 8.26 cfs @ 12.65 hrs, Volume= 1.285 af
Primary = 8.26 cfs @ 12.65 hrs, Volume= 1.285 af, Atten= 0%, Lag= 0.0 min

Primary outflow = Inflow, Time Span= 0.00-24.00 hrs, dt= 0.05 hrs

Link DP2B: DP-2B

Hydrograph

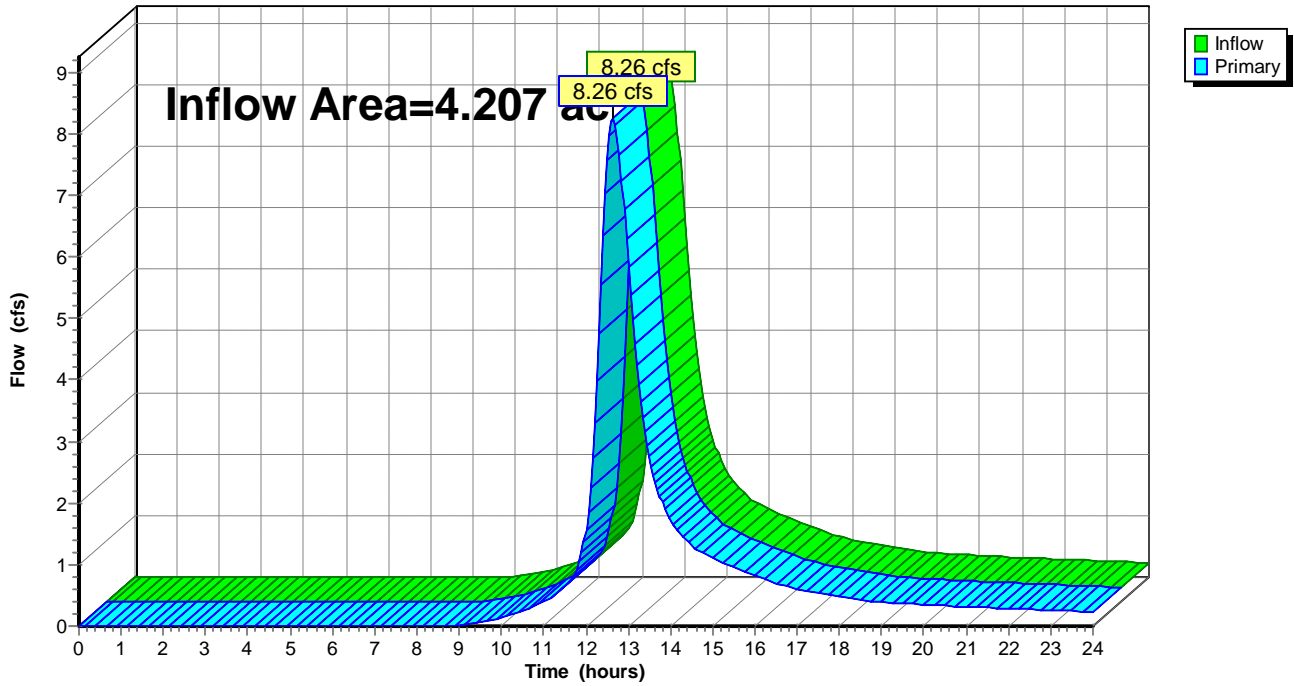

Summary for Link DP3: DP-3

Inflow Area = 4.981 ac, 7.60% Impervious, Inflow Depth > 3.99" for 100-Year event
Inflow = 12.42 cfs @ 12.48 hrs, Volume= 1.658 af
Primary = 12.42 cfs @ 12.48 hrs, Volume= 1.658 af, Atten= 0%, Lag= 0.0 min

Primary outflow = Inflow, Time Span= 0.00-24.00 hrs, dt= 0.05 hrs

Link DP3: DP-3

Hydrograph

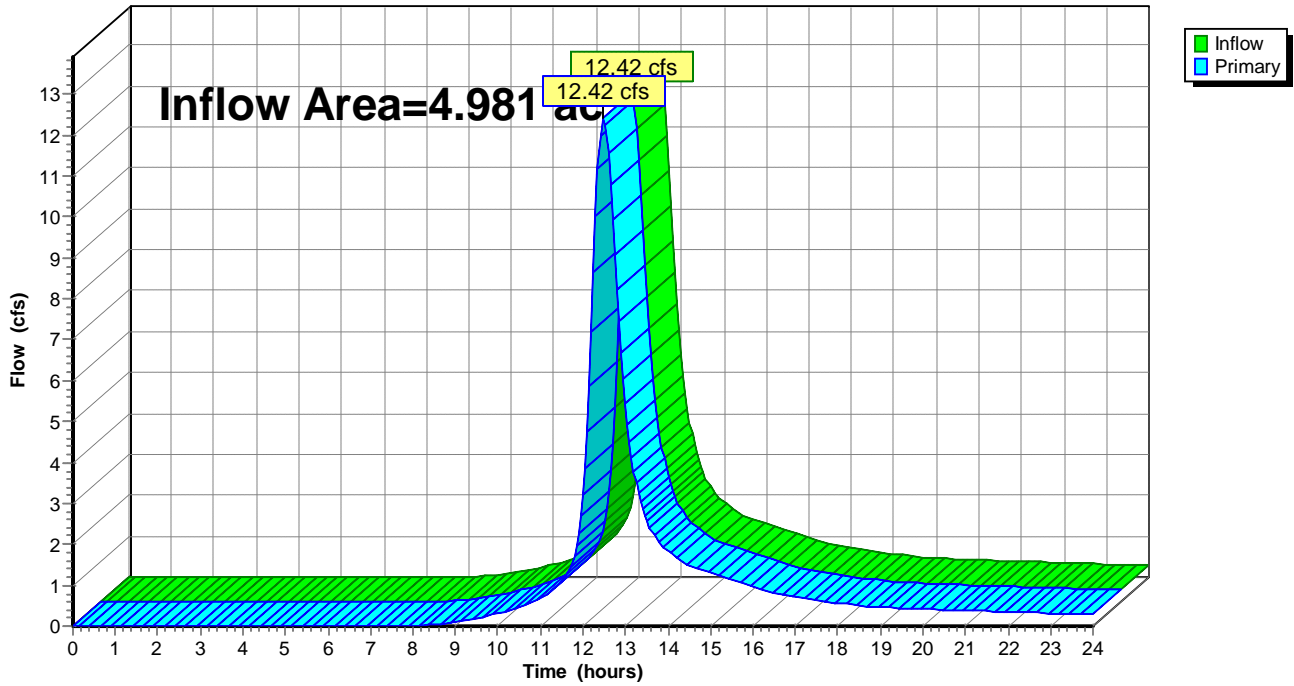

Summary for Link DP4: DP-4

Inflow Area = 0.893 ac, 5.13% Impervious, Inflow Depth > 4.12" for 100-Year event
Inflow = 3.41 cfs @ 12.18 hrs, Volume= 0.307 af
Primary = 3.41 cfs @ 12.18 hrs, Volume= 0.307 af, Atten= 0%, Lag= 0.0 min

Primary outflow = Inflow, Time Span= 0.00-24.00 hrs, dt= 0.05 hrs

Link DP4: DP-4

Hydrograph

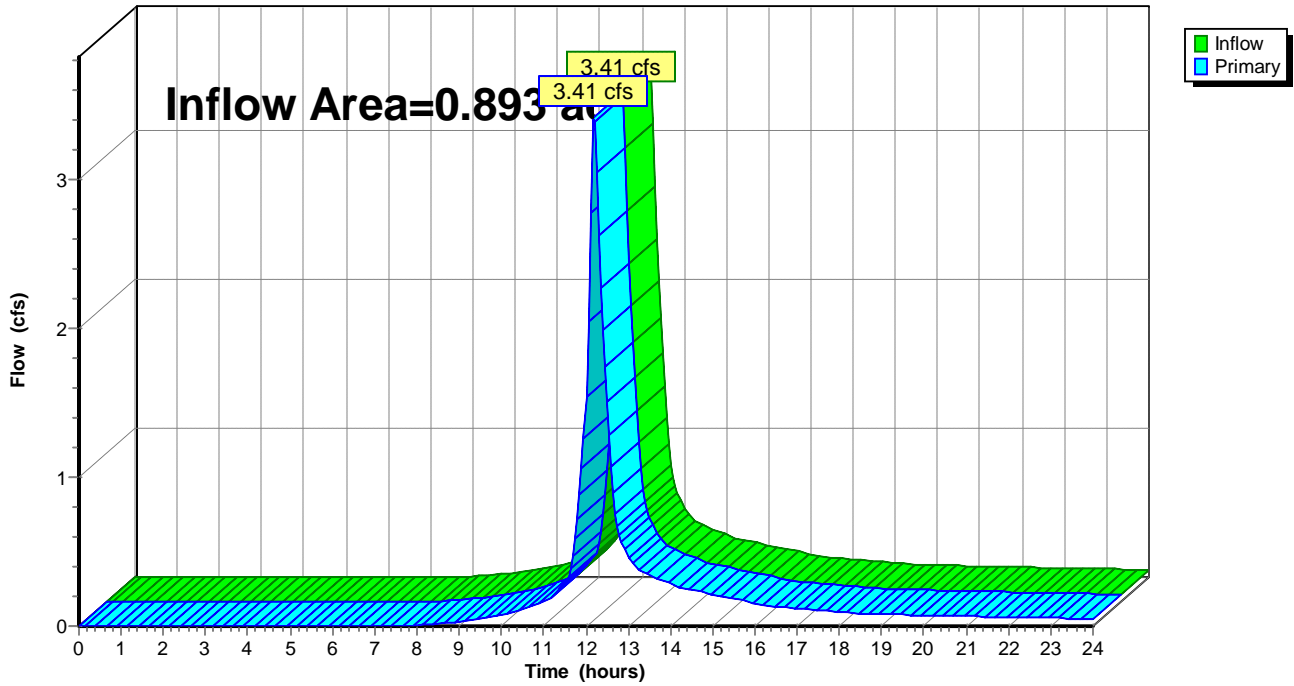

Summary for Link DP5: DP-5

Inflow Area = 1.764 ac, 11.76% Impervious, Inflow Depth > 4.45" for 100-Year event
Inflow = 7.66 cfs @ 12.16 hrs, Volume= 0.654 af
Primary = 7.66 cfs @ 12.16 hrs, Volume= 0.654 af, Atten= 0%, Lag= 0.0 min

Primary outflow = Inflow, Time Span= 0.00-24.00 hrs, dt= 0.05 hrs

Link DP5: DP-5

Hydrograph

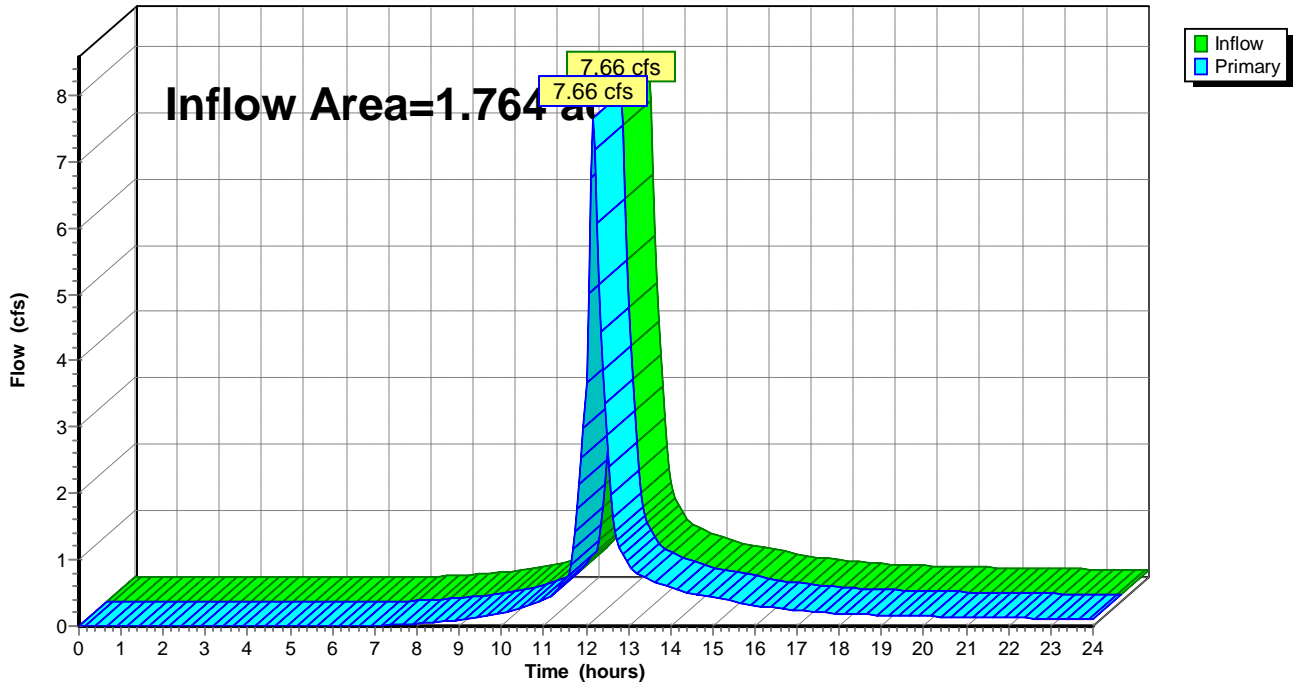

Summary for Link DP6: DP-6

Inflow Area = 1.435 ac, 2.87% Impervious, Inflow Depth > 4.23" for 100-Year event
Inflow = 6.49 cfs @ 12.12 hrs, Volume= 0.506 af
Primary = 6.49 cfs @ 12.12 hrs, Volume= 0.506 af, Atten= 0%, Lag= 0.0 min

Primary outflow = Inflow, Time Span= 0.00-24.00 hrs, dt= 0.05 hrs

Link DP6: DP-6

Hydrograph

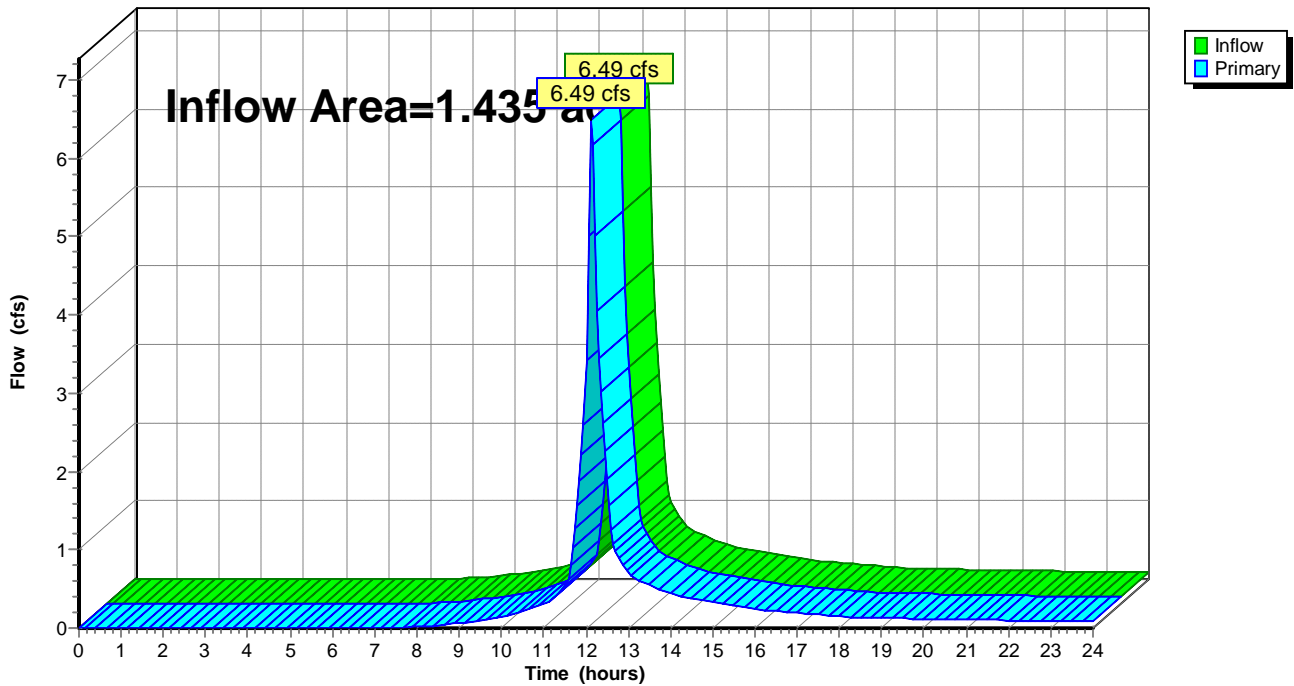

Appendix C – Proposed Conditions HydroCAD Routing

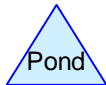
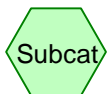
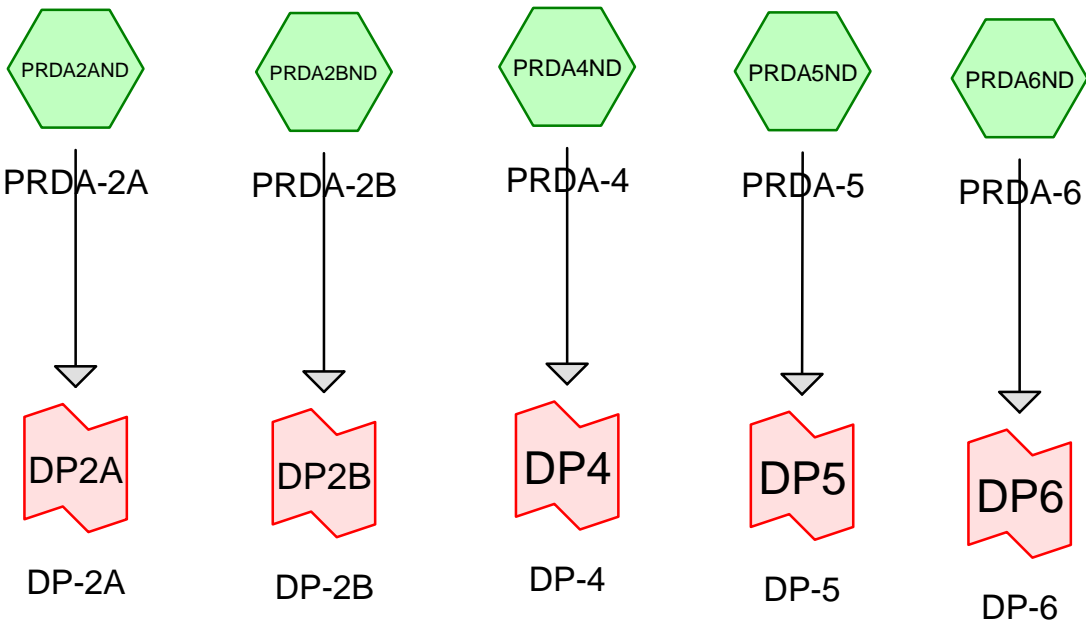
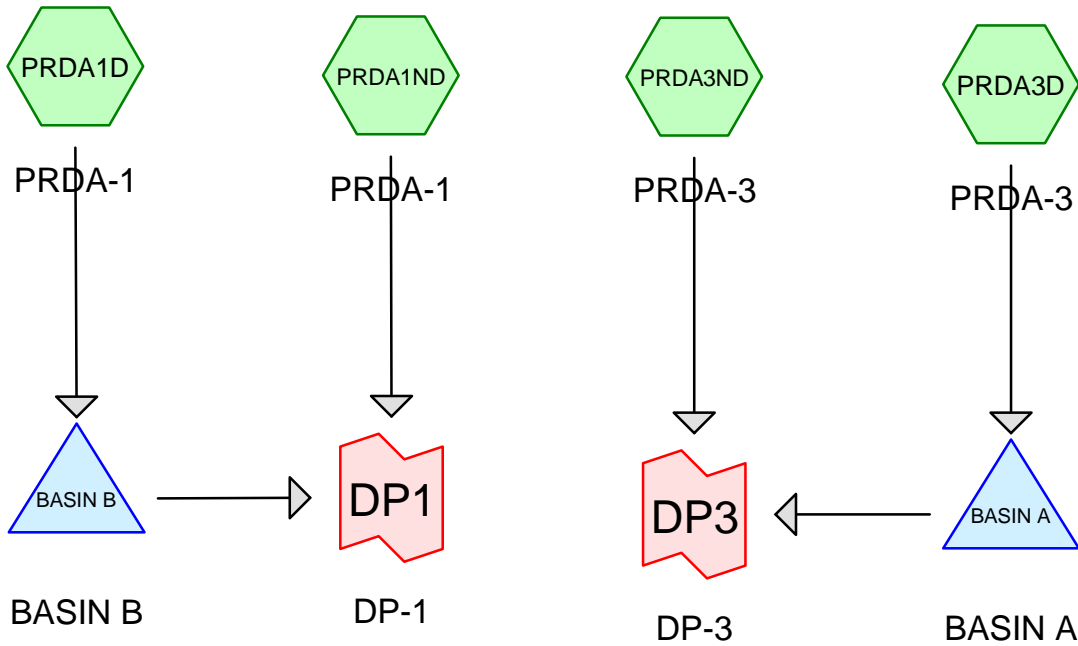

Area Listing (selected nodes)

Area (acres)	CN	Description (subcatchment-numbers)
8.638	75	Gravel, HSG C (PRDA1D, PRDA3D)
0.046	98	Impervious (PRDA4ND)
4.716	98	Impervious, HSG C (PRDA1D, PRDA1ND, PRDA3D, PRDA3ND, PRDA5ND, PRDA6ND)
13.568	74	Pasture/grassland/range, Good, HSG C (PRDA1D, PRDA1ND, PRDA2AND, PRDA2BND, PRDA3ND, PRDA4ND, PRDA5ND, PRDA6ND)
0.866	98	Roofs, HSG C (PRDA1D, PRDA3D)
1.380	98	Water Surface, HSG C (PRDA1D, PRDA3D)
5.932	70	Woods, Good, HSG C (PRDA1D, PRDA1ND, PRDA2AND, PRDA2BND)
35.146	78	TOTAL AREA

Soil Listing (selected nodes)

Area (acres)	Soil Group	Subcatchment Numbers
0.000	HSG A	
0.000	HSG B	
35.100	HSG C	PRDA1D, PRDA1ND, PRDA2AND, PRDA2BND, PRDA3D, PRDA3ND, PRDA4ND, PRDA5ND, PRDA6ND
0.000	HSG D	
0.046	Other	PRDA4ND
35.146		TOTAL AREA

Ground Covers (selected nodes)

HSG-A (acres)	HSG-B (acres)	HSG-C (acres)	HSG-D (acres)	Other (acres)	Total (acres)	Ground Cover	Subcatchment Numbers
0.000	0.000	8.638	0.000	0.000	8.638	Gravel	PRDA1D, PRDA3D
0.000	0.000	4.716	0.000	0.046	4.762	Impervious	PRDA1D, PRDA1ND, PRDA3D, PRDA3ND, PRDA4ND, PRDA5ND, PRDA6ND
0.000	0.000	13.568	0.000	0.000	13.568	Pasture/grassland/range, Good	PRDA1D, PRDA1ND, PRDA2AND, PRDA2BND, PRDA3ND, PRDA4ND, PRDA5ND, PRDA6ND
0.000	0.000	0.866	0.000	0.000	0.866	Roofs	PRDA1D, PRDA3D
0.000	0.000	1.380	0.000	0.000	1.380	Water Surface	PRDA1D, PRDA3D
0.000	0.000	5.932	0.000	0.000	5.932	Woods, Good	PRDA1D, PRDA1ND, PRDA2AND, PRDA2BND
0.000	0.000	35.100	0.000	0.046	35.146	TOTAL AREA	

Pipe Listing (selected nodes)

Line#	Node Number	In-Invert (feet)	Out-Invert (feet)	Length (feet)	Slope (ft/ft)	n	Diam/Width (inches)	Height (inches)	Inside-Fill (inches)
1	PRDA3D	0.00	0.00	1,200.0	0.0075	0.010	15.0	0.0	0.0
2	PRDA5ND	0.00	0.00	100.0	0.0100	0.010	15.0	0.0	0.0
3	BASIN A	820.00	786.00	250.0	0.1360	0.010	15.0	0.0	0.0
4	BASIN B	821.00	797.00	100.0	0.2400	0.010	18.0	0.0	0.0

Time span=0.00-24.00 hrs, dt=0.05 hrs, 481 points
 Runoff by SCS TR-20 method, UH=SCS, Weighted-CN
 Reach routing by Stor-Ind+Trans method - Pond routing by Stor-Ind method

Subcatchment PRDA1D: PRDA-1	Runoff Area=360,934 sf 15.66% Impervious Runoff Depth>1.27" Flow Length=850' Tc=42.4 min CN=77 Runoff=5.80 cfs 0.877 af
Subcatchment PRDA1ND: PRDA-1	Runoff Area=430,511 sf 13.86% Impervious Runoff Depth>1.21" Flow Length=1,775' Tc=42.9 min CN=76 Runoff=6.49 cfs 0.996 af
Subcatchment PRDA2AND: PRDA-2A	Runoff Area=103,805 sf 0.00% Impervious Runoff Depth>0.99" Flow Length=400' Tc=24.1 min CN=72 Runoff=1.60 cfs 0.196 af
Subcatchment PRDA2BND: PRDA-2B	Runoff Area=85,134 sf 0.00% Impervious Runoff Depth>0.99" Flow Length=300' Tc=17.4 min CN=72 Runoff=1.50 cfs 0.161 af
Subcatchment PRDA3D: PRDA-3	Runoff Area=407,573 sf 36.10% Impervious Runoff Depth>1.69" Flow Length=1,450' Tc=6.7 min CN=83 Runoff=17.85 cfs 1.318 af
Subcatchment PRDA3ND: PRDA-3	Runoff Area=21,688 sf 76.07% Impervious Runoff Depth>2.44" Flow Length=100' Slope=0.1100 '/' Tc=5.0 min CN=92 Runoff=1.40 cfs 0.101 af
Subcatchment PRDA4ND: PRDA-4	Runoff Area=9,707 sf 20.57% Impervious Runoff Depth>1.41" Flow Length=100' Slope=0.1100 '/' Tc=5.0 min CN=79 Runoff=0.37 cfs 0.026 af
Subcatchment PRDA5ND: PRDA-5	Runoff Area=61,426 sf 22.51% Impervious Runoff Depth>1.41" Flow Length=300' Tc=5.7 min CN=79 Runoff=2.28 cfs 0.166 af
Subcatchment PRDA6ND: PRDA-6	Runoff Area=50,175 sf 19.16% Impervious Runoff Depth>1.41" Flow Length=650' Tc=5.6 min CN=79 Runoff=1.87 cfs 0.135 af
Pond BASIN A: BASIN A	Peak Elev=820.95' Storage=30,992 cf Inflow=17.85 cfs 1.318 af Outflow=1.32 cfs 1.008 af
Pond BASIN B: BASIN B	Peak Elev=822.40' Storage=15,365 cf Inflow=5.80 cfs 0.877 af Outflow=1.82 cfs 0.798 af
Link DP1: DP-1	Inflow=7.21 cfs 1.793 af Primary=7.21 cfs 1.793 af
Link DP2A: DP-2A	Inflow=1.60 cfs 0.196 af Primary=1.60 cfs 0.196 af
Link DP2B: DP-2B	Inflow=1.50 cfs 0.161 af Primary=1.50 cfs 0.161 af
Link DP3: DP-3	Inflow=1.99 cfs 1.109 af Primary=1.99 cfs 1.109 af
Link DP4: DP-4	Inflow=0.37 cfs 0.026 af Primary=0.37 cfs 0.026 af

98132 PR SC

Prepared by CIVIL 1

HydroCAD® 10.00-13 s/n 08208 © 2014 HydroCAD Software Solutions LLC

Type III 24-hr 2-Year Rainfall=3.30"

Printed 2/13/2015

Page 7

Link DP5: DP-5

Inflow=2.28 cfs 0.166 af
Primary=2.28 cfs 0.166 af

Link DP6: DP-6

Inflow=1.87 cfs 0.135 af
Primary=1.87 cfs 0.135 af

Total Runoff Area = 35.146 ac Runoff Volume = 3.976 af Average Runoff Depth = 1.36"
80.06% Pervious = 28.138 ac 19.94% Impervious = 7.008 ac

Summary for Subcatchment PRDA1D: PRDA-1

Runoff = 5.80 cfs @ 12.61 hrs, Volume= 0.877 af, Depth> 1.27"

Runoff by SCS TR-20 method, UH=SCS, Weighted-CN, Time Span= 0.00-24.00 hrs, dt= 0.05 hrs
 Type III 24-hr 2-Year Rainfall=3.30"

Area (sf)	CN	Description
36,718	98	Impervious, HSG C
1,151	98	Roofs, HSG C
18,667	98	Water Surface, HSG C
124,441	74	Pasture/grassland/range, Good, HSG C
* 115,820	75	Gravel, HSG C
64,137	70	Woods, Good, HSG C
360,934	77	Weighted Average
304,398		84.34% Pervious Area
56,536		15.66% Impervious Area

Tc (min)	Length (feet)	Slope (ft/ft)	Velocity (ft/sec)	Capacity (cfs)	Description
37.0	250	0.0320	0.11		Sheet Flow, Woods: Light underbrush n= 0.400 P2= 3.20"
5.4	600	0.0700	1.85		Shallow Concentrated Flow, Short Grass Pasture Kv= 7.0 fps
42.4	850	Total			

Subcatchment PRDA1D: PRDA-1

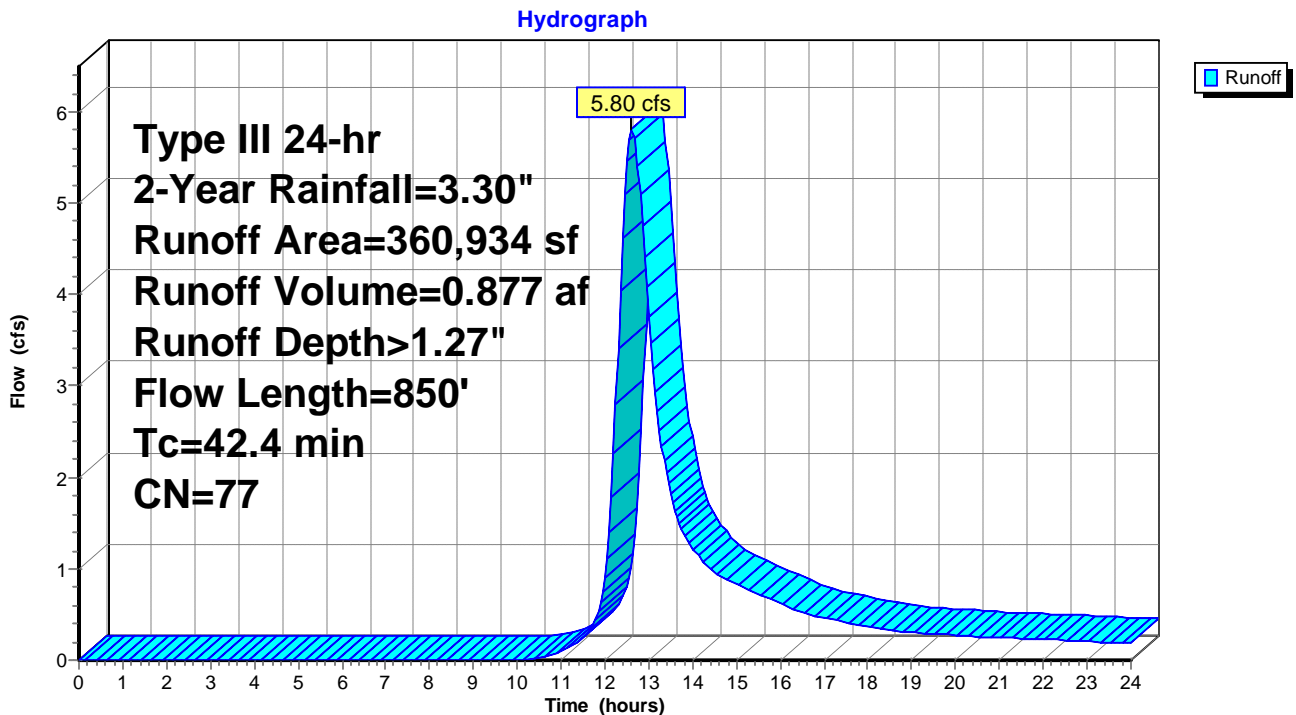

Summary for Subcatchment PRDA1ND: PRDA-1

Runoff = 6.49 cfs @ 12.63 hrs, Volume= 0.996 af, Depth> 1.21"

Runoff by SCS TR-20 method, UH=SCS, Weighted-CN, Time Span= 0.00-24.00 hrs, dt= 0.05 hrs
 Type III 24-hr 2-Year Rainfall=3.30"

Area (sf)	CN	Description
114,584	70	Woods, Good, HSG C
256,245	74	Pasture/grassland/range, Good, HSG C
59,682	98	Impervious, HSG C
430,511	76	Weighted Average
370,829		86.14% Pervious Area
59,682		13.86% Impervious Area

Tc (min)	Length (feet)	Slope (ft/ft)	Velocity (ft/sec)	Capacity (cfs)	Description
37.0	250	0.0320	0.11		Sheet Flow, Woods: Light underbrush n= 0.400 P2= 3.20"
4.9	1,000	0.0440	3.38		Shallow Concentrated Flow, Unpaved Kv= 16.1 fps
1.0	525	0.0570	8.87	53.22	Channel Flow, Area= 6.0 sf Perim= 6.0' r= 1.00' n= 0.040 Earth, cobble bottom, clean sides

42.9 1,775 Total

Subcatchment PRDA1ND: PRDA-1

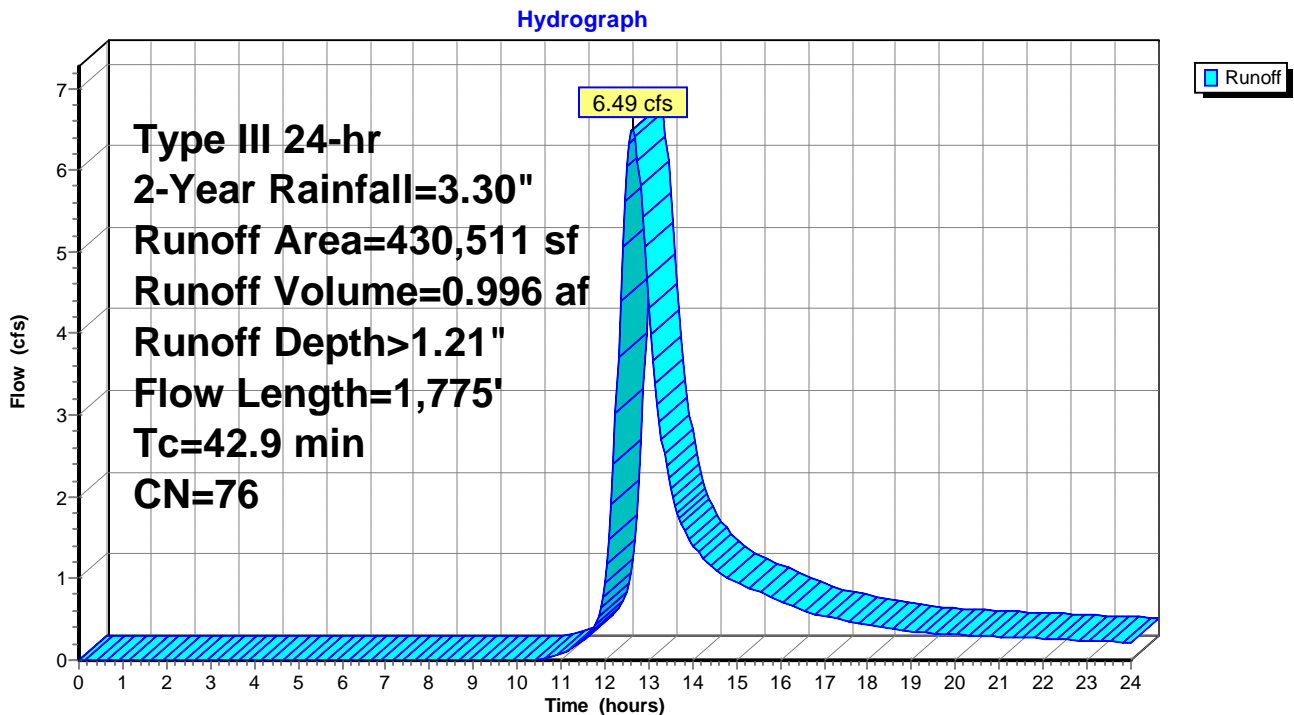

Summary for Subcatchment PRDA2AND: PRDA-2A

Runoff = 1.60 cfs @ 12.37 hrs, Volume= 0.196 af, Depth> 0.99"

Runoff by SCS TR-20 method, UH=SCS, Weighted-CN, Time Span= 0.00-24.00 hrs, dt= 0.05 hrs
 Type III 24-hr 2-Year Rainfall=3.30"

Area (sf)	CN	Description
46,490	70	Woods, Good, HSG C
57,315	74	Pasture/grassland/range, Good, HSG C
103,805	72	Weighted Average
103,805		100.00% Pervious Area

Tc (min)	Length (feet)	Slope (ft/ft)	Velocity (ft/sec)	Capacity (cfs)	Description
23.1	250	0.1040	0.18		Sheet Flow, Woods: Light underbrush n= 0.400 P2= 3.20"
1.0	150	0.2400	2.45		Shallow Concentrated Flow, Woodland Kv= 5.0 fps
24.1	400	Total			

Subcatchment PRDA2AND: PRDA-2A

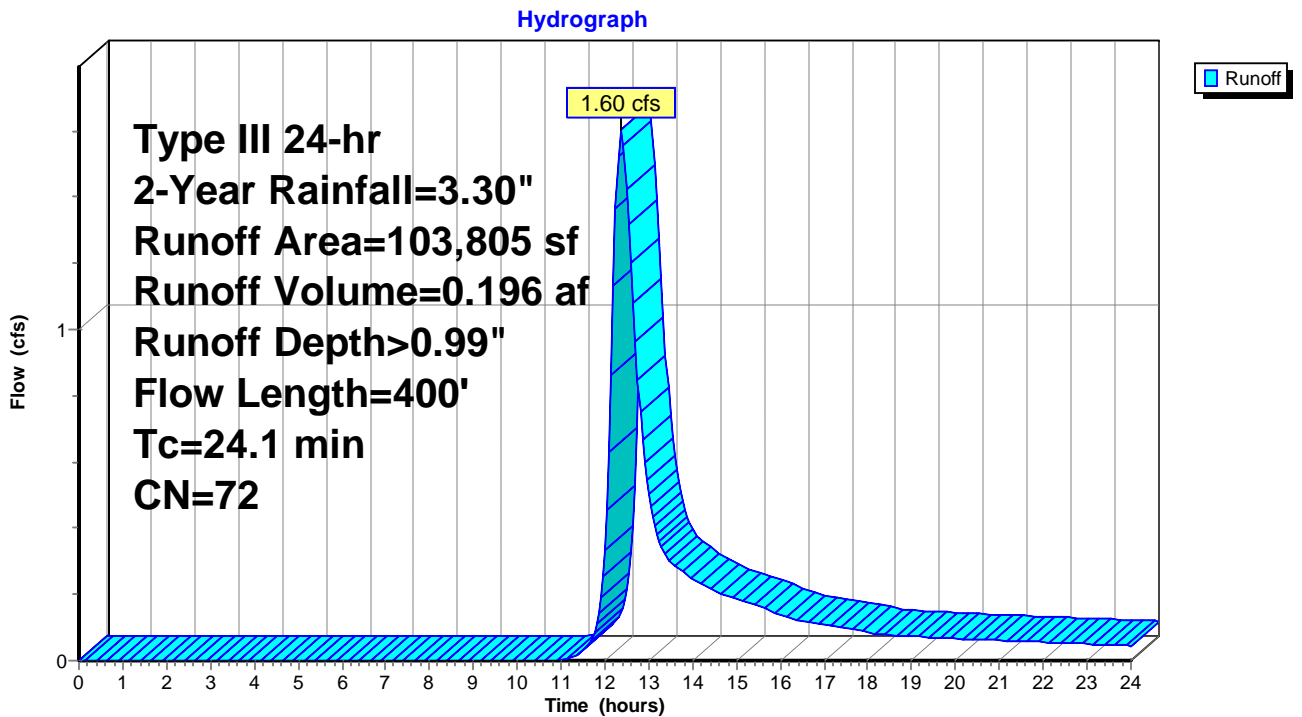

Summary for Subcatchment PRDA2BND: PRDA-2B

Runoff = 1.50 cfs @ 12.26 hrs, Volume= 0.161 af, Depth> 0.99"

Runoff by SCS TR-20 method, UH=SCS, Weighted-CN, Time Span= 0.00-24.00 hrs, dt= 0.05 hrs
 Type III 24-hr 2-Year Rainfall=3.30"

Area (sf)	CN	Description
33,200	70	Woods, Good, HSG C
51,934	74	Pasture/grassland/range, Good, HSG C
85,134	72	Weighted Average
85,134		100.00% Pervious Area

Tc (min)	Length (feet)	Slope (ft/ft)	Velocity (ft/sec)	Capacity (cfs)	Description
16.1	200	0.1650	0.21		Sheet Flow, Woods: Light underbrush n= 0.400 P2= 3.20"
1.3	100	0.0700	1.32		Shallow Concentrated Flow, Woodland Kv= 5.0 fps
17.4	300	Total			

Subcatchment PRDA2BND: PRDA-2B

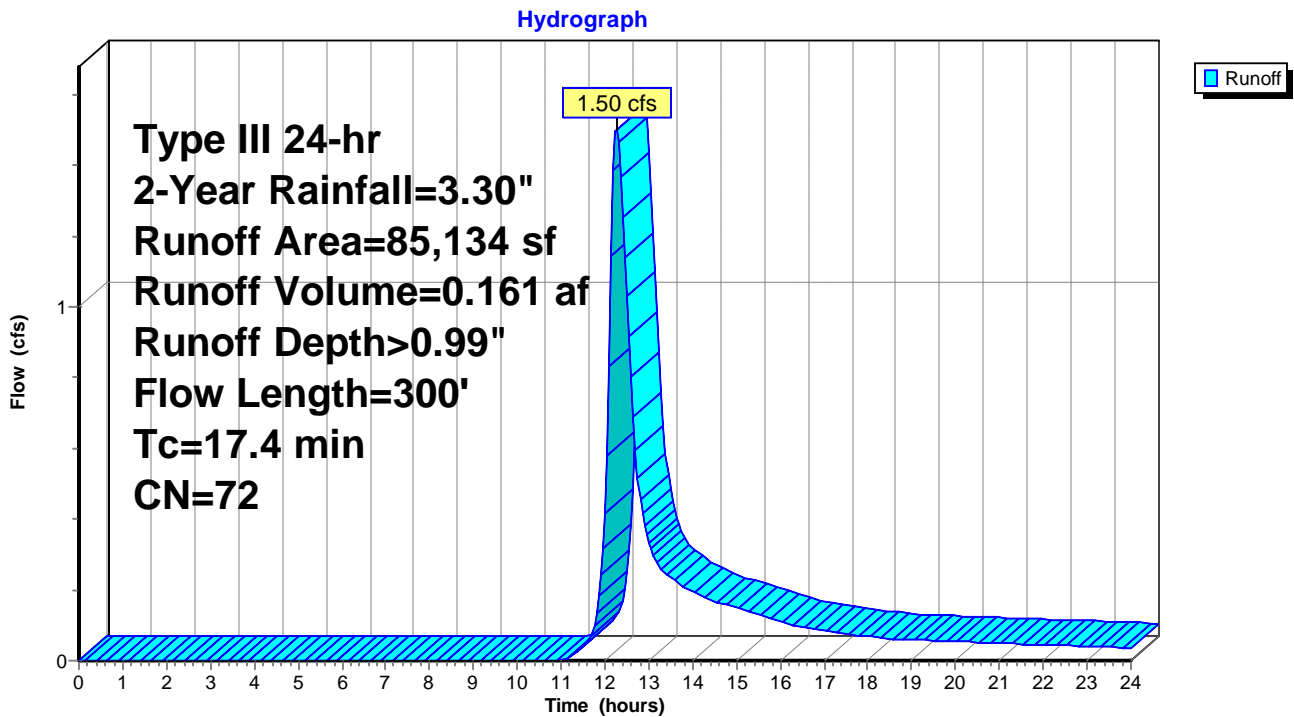

Summary for Subcatchment PRDA3D: PRDA-3

Runoff = 17.85 cfs @ 12.10 hrs, Volume= 1.318 af, Depth> 1.69"

Runoff by SCS TR-20 method, UH=SCS, Weighted-CN, Time Span= 0.00-24.00 hrs, dt= 0.05 hrs
 Type III 24-hr 2-Year Rainfall=3.30"

Area (sf)	CN	Description
69,087	98	Impervious, HSG C
36,569	98	Roofs, HSG C
41,458	98	Water Surface, HSG C
* 260,459	75	Gravel, HSG C
407,573	83	Weighted Average
260,459		63.90% Pervious Area
147,114		36.10% Impervious Area

Tc (min)	Length (feet)	Slope (ft/ft)	Velocity (ft/sec)	Capacity (cfs)	Description
3.3	250	0.0100	1.25		Sheet Flow, Smooth surfaces n= 0.011 P2= 3.20"
3.4	1,200	0.0075	5.93	7.27	Pipe Channel, 15.0" Round Area= 1.2 sf Perim= 3.9' r= 0.31' n= 0.010 PVC, smooth interior
6.7	1,450	Total			

Subcatchment PRDA3D: PRDA-3

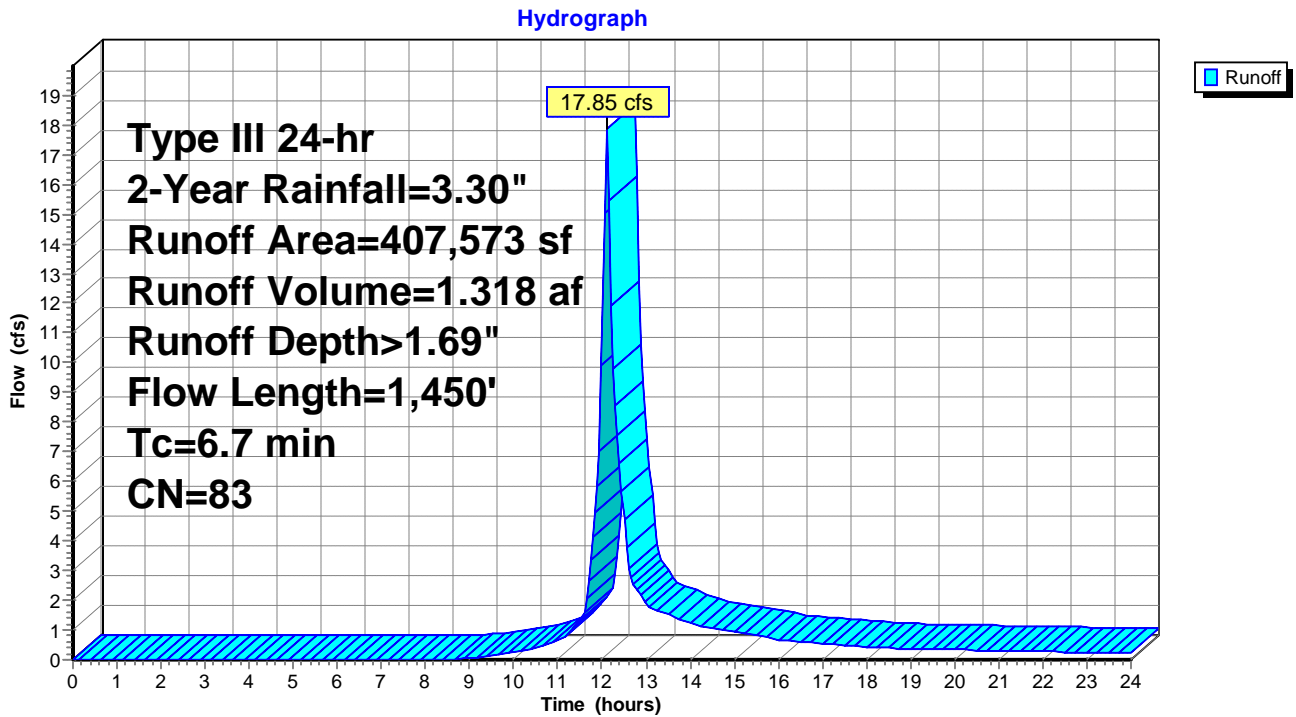

Summary for Subcatchment PRDA3ND: PRDA-3

Runoff = 1.40 cfs @ 12.07 hrs, Volume= 0.101 af, Depth> 2.44"

Runoff by SCS TR-20 method, UH=SCS, Weighted-CN, Time Span= 0.00-24.00 hrs, dt= 0.05 hrs
 Type III 24-hr 2-Year Rainfall=3.30"

Area (sf)	CN	Description
5,191	74	Pasture/grassland/range, Good, HSG C
16,497	98	Impervious, HSG C
21,688	92	Weighted Average
5,191		23.93% Pervious Area
16,497		76.07% Impervious Area

Tc (min)	Length (feet)	Slope (ft/ft)	Velocity (ft/sec)	Capacity (cfs)	Description
5.0	100	0.1100	0.34		Sheet Flow, Grass: Short n= 0.150 P2= 3.20"

Subcatchment PRDA3ND: PRDA-3

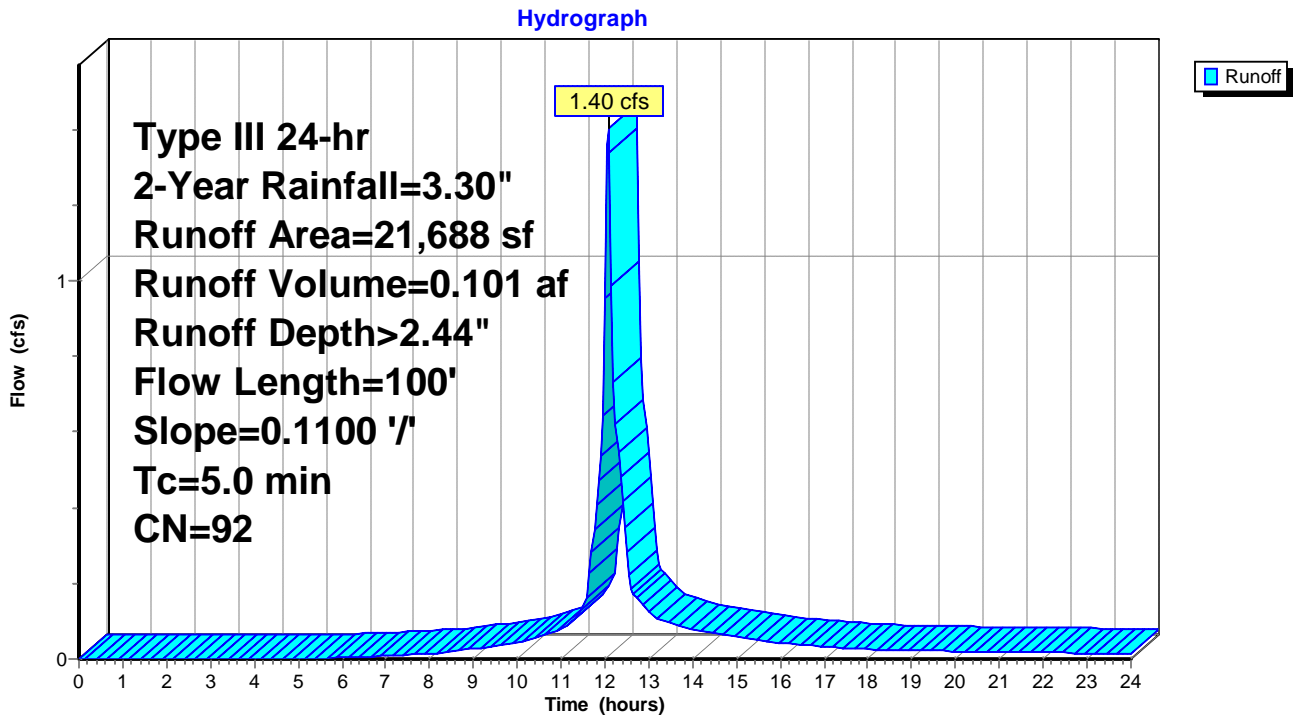

Summary for Subcatchment PRDA4ND: PRDA-4

Runoff = 0.37 cfs @ 12.08 hrs, Volume= 0.026 af, Depth> 1.41"

Runoff by SCS TR-20 method, UH=SCS, Weighted-CN, Time Span= 0.00-24.00 hrs, dt= 0.05 hrs
 Type III 24-hr 2-Year Rainfall=3.30"

Area (sf)	CN	Description
7,710	74	Pasture/grassland/range, Good, HSG C
* 1,997	98	Impervious
9,707	79	Weighted Average
7,710		79.43% Pervious Area
1,997		20.57% Impervious Area

Tc (min)	Length (feet)	Slope (ft/ft)	Velocity (ft/sec)	Capacity (cfs)	Description
5.0	100	0.1100	0.34		Sheet Flow, Grass: Short n= 0.150 P2= 3.20"

Subcatchment PRDA4ND: PRDA-4

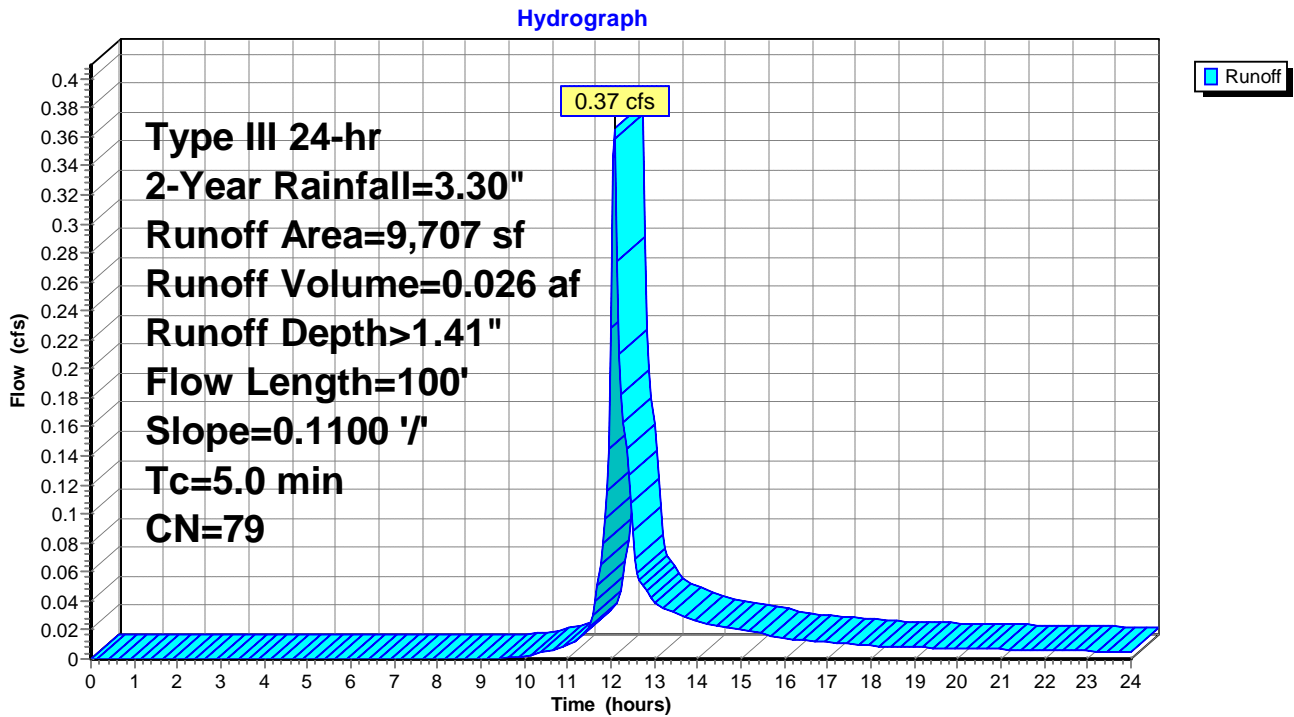

Summary for Subcatchment PRDA5ND: PRDA-5

Runoff = 2.28 cfs @ 12.09 hrs, Volume= 0.166 af, Depth> 1.41"

Runoff by SCS TR-20 method, UH=SCS, Weighted-CN, Time Span= 0.00-24.00 hrs, dt= 0.05 hrs
 Type III 24-hr 2-Year Rainfall=3.30"

Area (sf)	CN	Description
13,824	98	Impervious, HSG C
47,602	74	Pasture/grassland/range, Good, HSG C
61,426	79	Weighted Average
47,602		77.49% Pervious Area
13,824		22.51% Impervious Area

Tc (min)	Length (feet)	Slope (ft/ft)	Velocity (ft/sec)	Capacity (cfs)	Description
5.5	200	0.3333	0.60		Sheet Flow, Grass: Short n= 0.150 P2= 3.20"
0.2	100	0.0100	6.84	8.40	Pipe Channel, 15.0" Round Area= 1.2 sf Perim= 3.9' r= 0.31' n= 0.010 PVC, smooth interior
5.7	300	Total			

Subcatchment PRDA5ND: PRDA-5

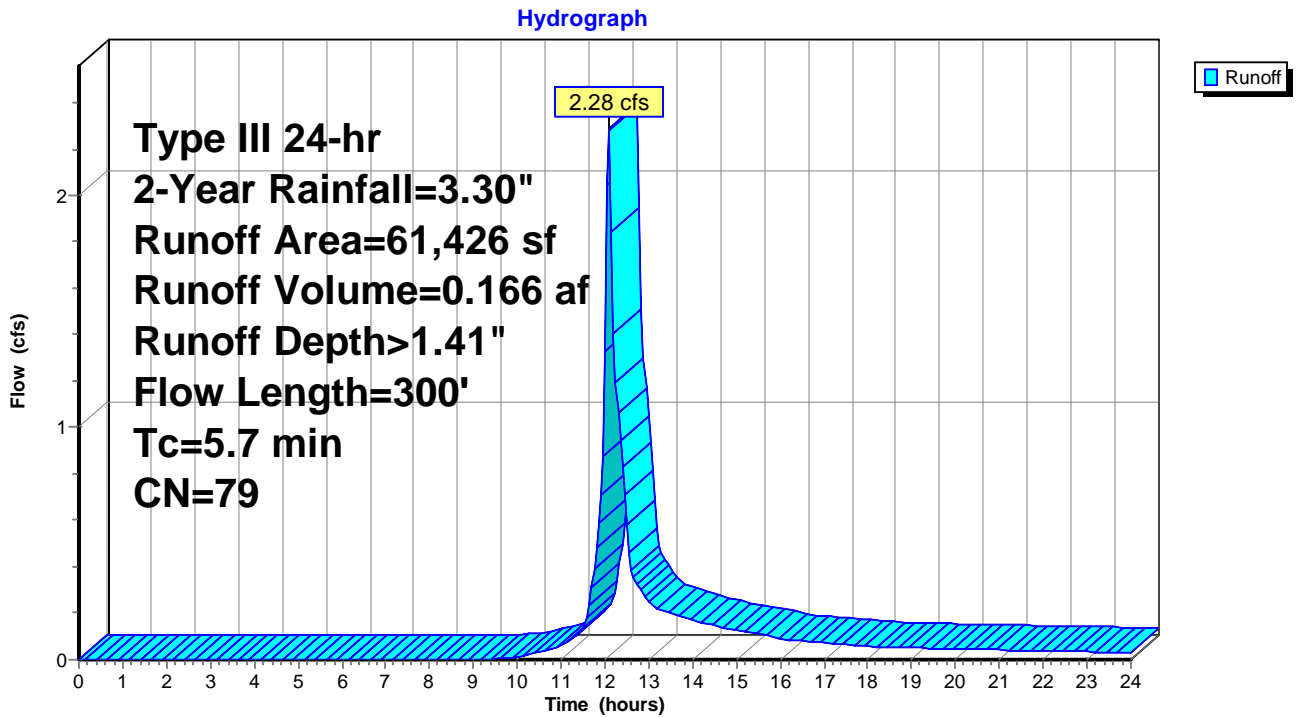

Summary for Subcatchment PRDA6ND: PRDA-6

Runoff = 1.87 cfs @ 12.09 hrs, Volume= 0.135 af, Depth> 1.41"

Runoff by SCS TR-20 method, UH=SCS, Weighted-CN, Time Span= 0.00-24.00 hrs, dt= 0.05 hrs
 Type III 24-hr 2-Year Rainfall=3.30"

Area (sf)	CN	Description
40,563	74	Pasture/grassland/range, Good, HSG C
9,612	98	Impervious, HSG C
50,175	79	Weighted Average
40,563		80.84% Pervious Area
9,612		19.16% Impervious Area

Tc (min)	Length (feet)	Slope (ft/ft)	Velocity (ft/sec)	Capacity (cfs)	Description
4.4	150	0.3333	0.57		Sheet Flow, Grass: Short n= 0.150 P2= 3.20"
1.2	500	0.2050	6.79		Shallow Concentrated Flow, Grassed Waterway Kv= 15.0 fps
5.6	650	Total			

Subcatchment PRDA6ND: PRDA-6

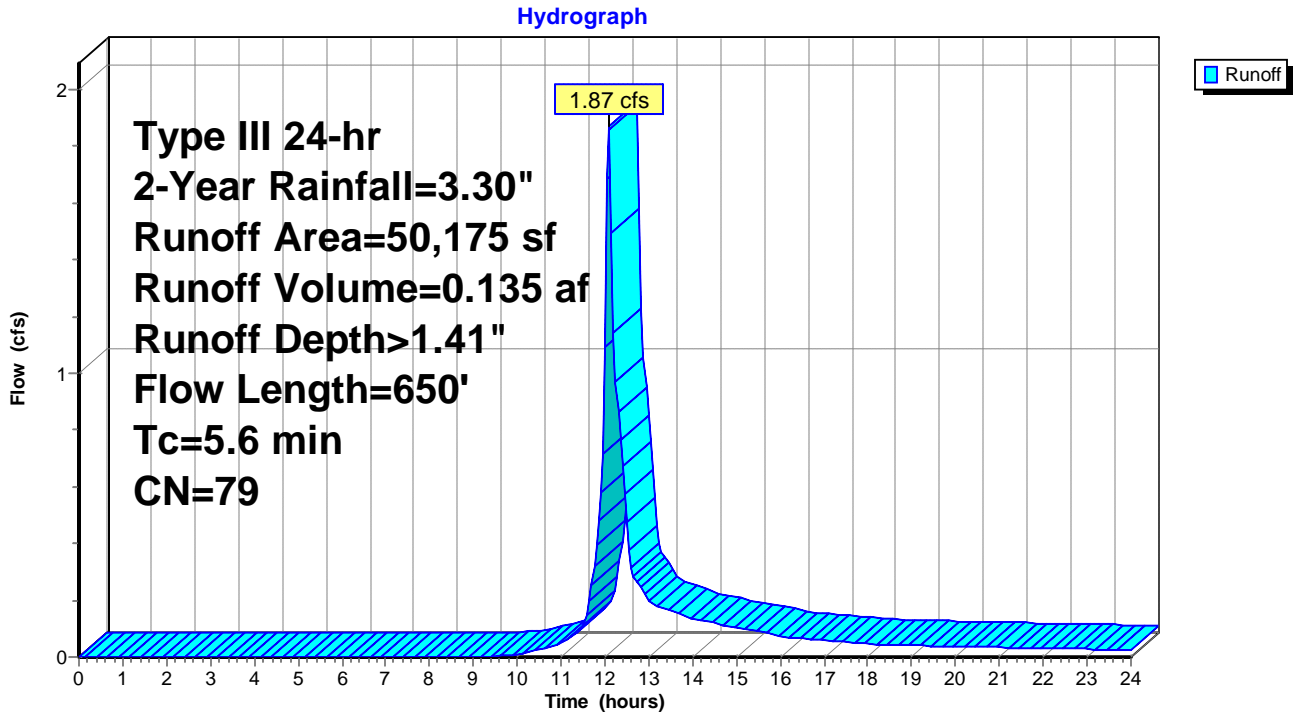

Summary for Pond BASIN A: BASIN A

Inflow Area = 9.357 ac, 36.10% Impervious, Inflow Depth > 1.69" for 2-Year event
 Inflow = 17.85 cfs @ 12.10 hrs, Volume= 1.318 af
 Outflow = 1.32 cfs @ 13.84 hrs, Volume= 1.008 af, Atten= 93%, Lag= 104.4 min
 Primary = 1.32 cfs @ 13.84 hrs, Volume= 1.008 af

Routing by Stor-Ind method, Time Span= 0.00-24.00 hrs, dt= 0.05 hrs
 Peak Elev= 820.95' @ 13.84 hrs Surf.Area= 34,112 sf Storage= 30,992 cf

Plug-Flow detention time= 284.2 min calculated for 1.006 af (76% of inflow)
 Center-of-Mass det. time= 199.4 min (1,030.8 - 831.5)

Volume	Invert	Avail.Storage	Storage Description
#1	820.00'	151,470 cf	Basin A (Irregular) Listed below (Recalc)

Elevation (feet)	Surf.Area (sq-ft)	Perim. (feet)	Inc.Store (cubic-feet)	Cum.Store (cubic-feet)	Wet.Area (sq-ft)
820.00	30,856	1,150.0	0	0	30,856
822.00	37,867	1,187.0	68,603	68,603	38,123
824.00	45,105	1,225.0	82,867	151,470	45,805

Device	Routing	Invert	Outlet Devices
#1	Primary	820.00'	15.0" Round Culvert L= 250.0' Ke= 0.500 Inlet / Outlet Invert= 820.00' / 786.00' S= 0.1360 '/' Cc= 0.900 n= 0.010 PVC, smooth interior, Flow Area= 1.23 sf
#2	Device 1	820.00'	8.0" Vert. Orifice/Grate C= 0.600
#3	Device 1	822.00'	15.0" W x 12.0" H Vert. Orifice/Grate X 2.00 C= 0.600

Primary OutFlow Max=1.32 cfs @ 13.84 hrs HW=820.95' (Free Discharge)

- 1=Culvert (Passes 1.32 cfs of 3.34 cfs potential flow)
- 2=Orifice/Grate (Orifice Controls 1.32 cfs @ 3.79 fps)
- 3=Orifice/Grate (Controls 0.00 cfs)

Pond BASIN A: BASIN A

Hydrograph

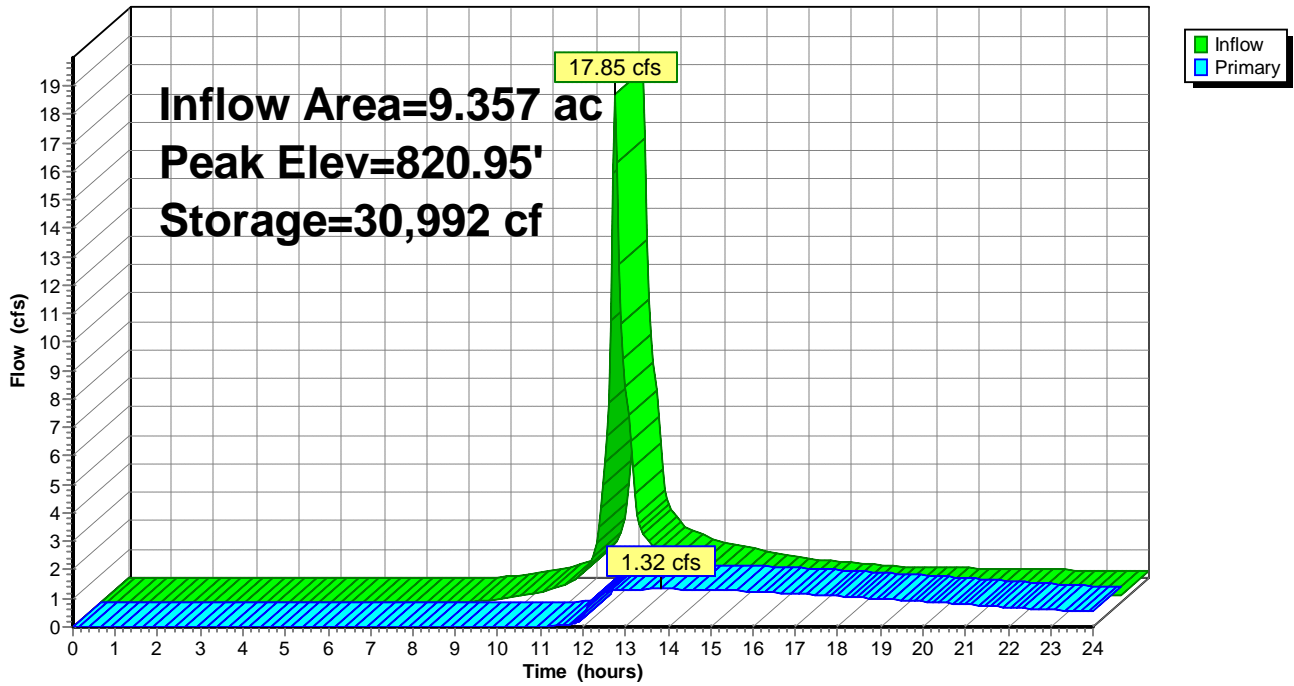

Summary for Pond BASIN B: BASIN B

Inflow Area = 8.286 ac, 15.66% Impervious, Inflow Depth > 1.27" for 2-Year event
 Inflow = 5.80 cfs @ 12.61 hrs, Volume= 0.877 af
 Outflow = 1.82 cfs @ 13.50 hrs, Volume= 0.798 af, Atten= 69%, Lag= 53.2 min
 Primary = 1.82 cfs @ 13.50 hrs, Volume= 0.798 af

Routing by Stor-Ind method, Time Span= 0.00-24.00 hrs, dt= 0.05 hrs
 Peak Elev= 822.40' @ 13.50 hrs Surf.Area= 12,535 sf Storage= 15,365 cf

Plug-Flow detention time= 166.5 min calculated for 0.798 af (91% of inflow)
 Center-of-Mass det. time= 123.8 min (1,002.1 - 878.3)

Volume	Invert	Avail.Storage	Storage Description		
#1	821.00'	122,878 cf	Basin B (Irregular) Listed below (Recalc)		
Elevation (feet)	Surf.Area (sq-ft)	Perim. (feet)	Inc.Store (cubic-feet)	Cum.Store (cubic-feet)	Wet.Area (sq-ft)
821.00	9,468	729.0	0	0	9,468
822.00	11,682	748.0	10,556	10,556	11,820
824.00	16,283	786.0	27,838	38,394	16,706
826.00	21,113	824.1	37,292	75,685	21,846
828.00	26,170	850.0	47,193	122,878	25,681

Device	Routing	Invert	Outlet Devices	
#1	Primary	821.00'	18.0" Round Culvert L= 100.0' Ke= 0.500 Inlet / Outlet Invert= 821.00' / 797.00' S= 0.2400 '/' Cc= 0.900 n= 0.010 PVC, smooth interior, Flow Area= 1.77 sf	
#2	Device 1	821.00'	6.0" Vert. Orifice/Grate C= 0.600	
#3	Device 1	822.00'	12.0" W x 30.0" H Vert. Orifice/Grate C= 0.600	
#4	Primary	825.00'	24.0" Vert. Orifice/Grate C= 0.600	

Primary OutFlow Max=1.82 cfs @ 13.50 hrs HW=822.40' (Free Discharge)

- 1=Culvert (Passes 1.82 cfs of 6.90 cfs potential flow)
- 2=Orifice/Grate (Orifice Controls 1.01 cfs @ 5.16 fps)
- 3=Orifice/Grate (Orifice Controls 0.80 cfs @ 2.02 fps)
- 4=Orifice/Grate (Controls 0.00 cfs)

Pond BASIN B: BASIN B

Hydrograph

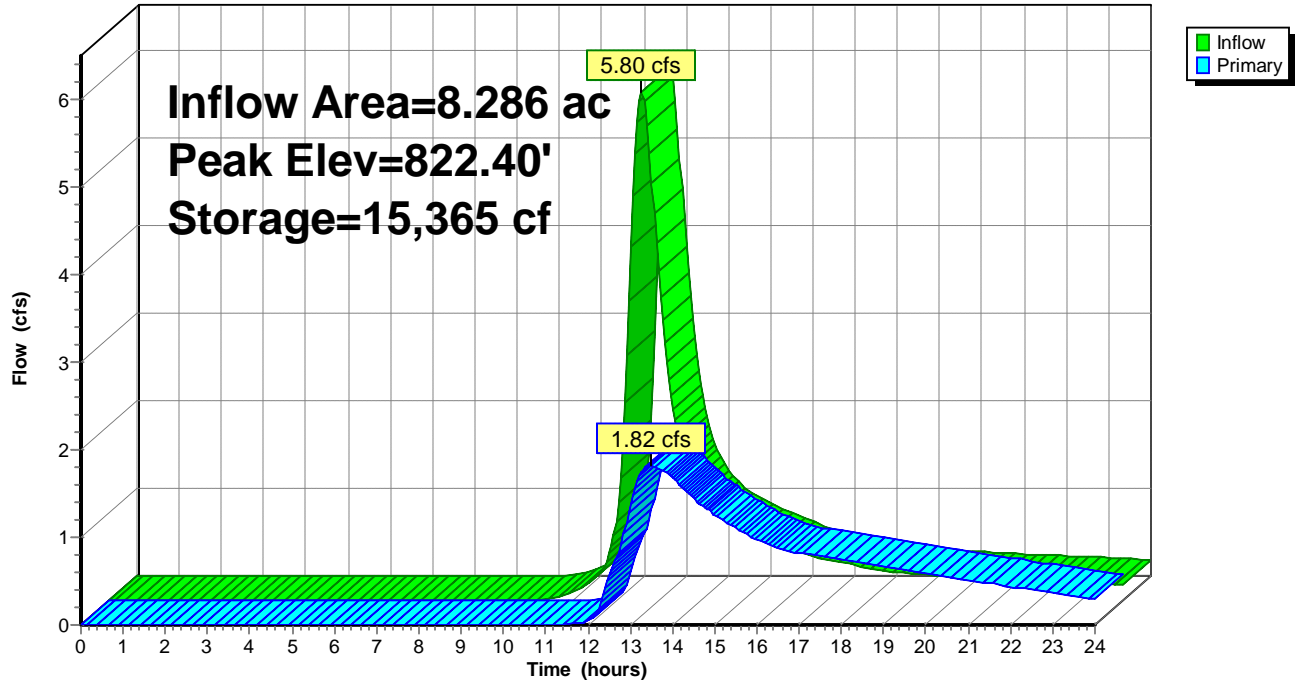

Summary for Link DP1: DP-1

Inflow Area = 18.169 ac, 14.68% Impervious, Inflow Depth > 1.18" for 2-Year event
Inflow = 7.21 cfs @ 12.65 hrs, Volume= 1.793 af
Primary = 7.21 cfs @ 12.65 hrs, Volume= 1.793 af, Atten= 0%, Lag= 0.0 min

Primary outflow = Inflow, Time Span= 0.00-24.00 hrs, dt= 0.05 hrs

Link DP1: DP-1

Hydrograph

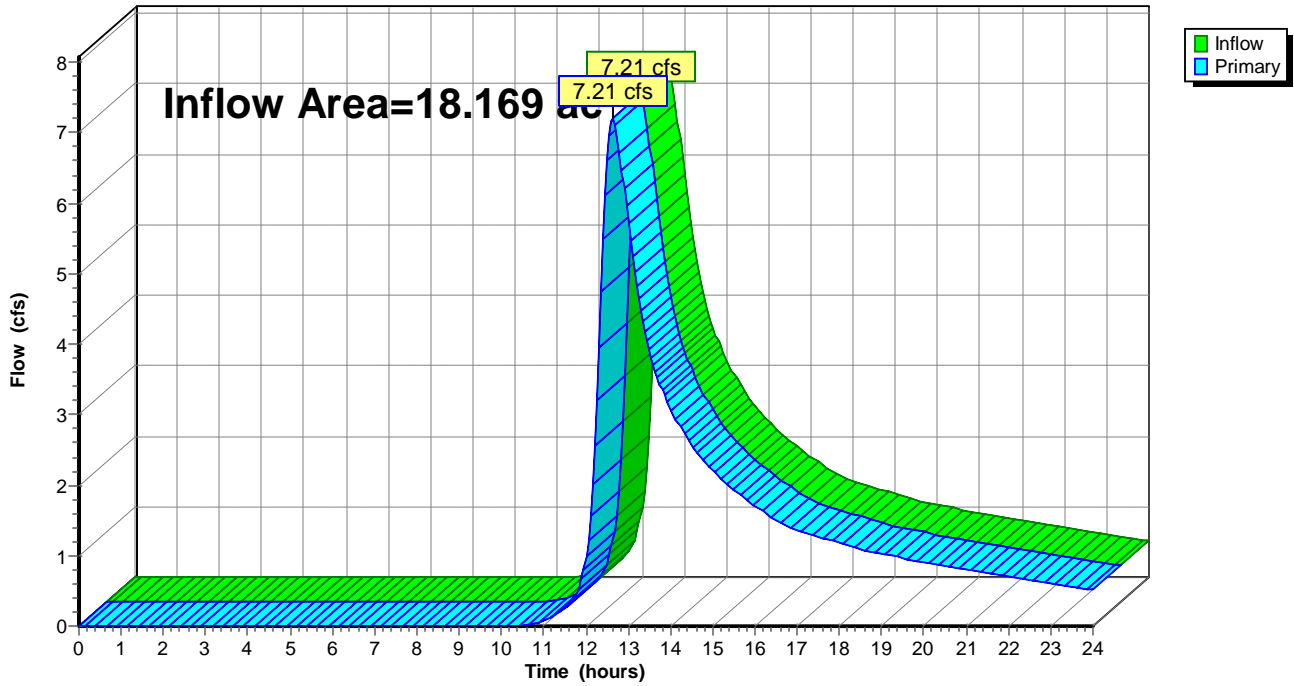

Summary for Link DP2A: DP-2A

Inflow Area = 2.383 ac, 0.00% Impervious, Inflow Depth > 0.99" for 2-Year event
Inflow = 1.60 cfs @ 12.37 hrs, Volume= 0.196 af
Primary = 1.60 cfs @ 12.37 hrs, Volume= 0.196 af, Atten= 0%, Lag= 0.0 min

Primary outflow = Inflow, Time Span= 0.00-24.00 hrs, dt= 0.05 hrs

Link DP2A: DP-2A

Hydrograph

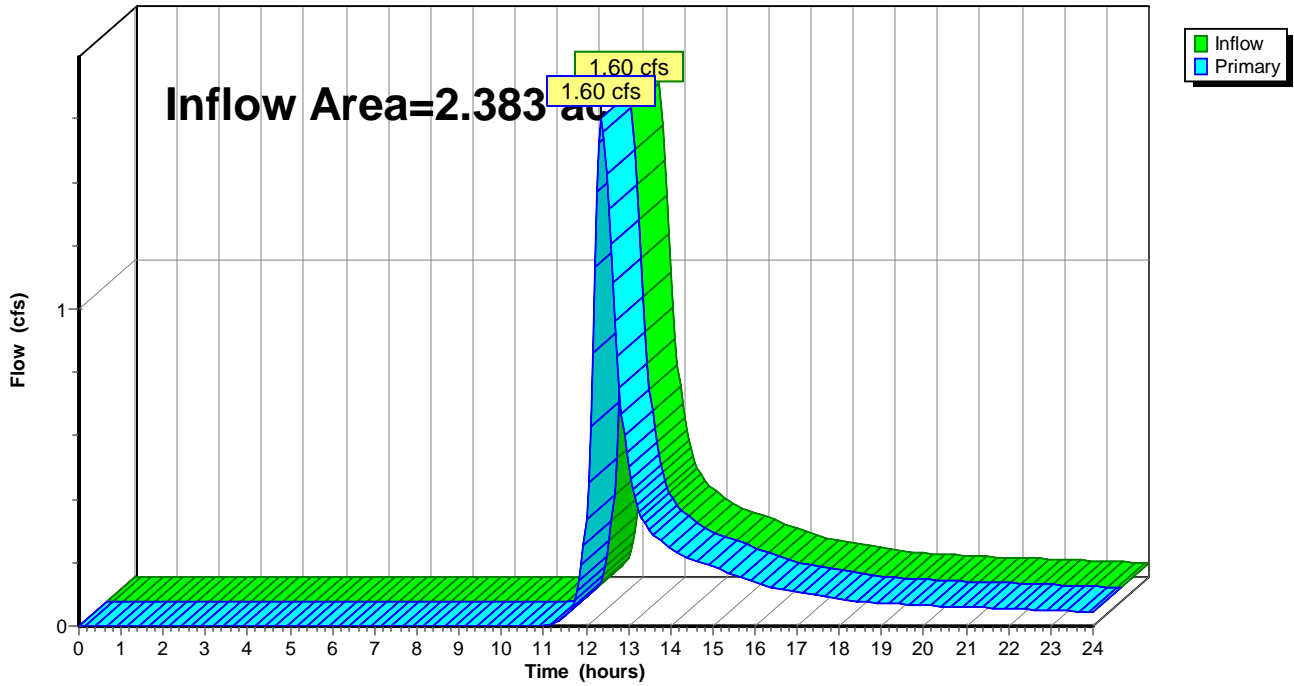

Summary for Link DP2B: DP-2B

Inflow Area = 1.954 ac, 0.00% Impervious, Inflow Depth > 0.99" for 2-Year event
Inflow = 1.50 cfs @ 12.26 hrs, Volume= 0.161 af
Primary = 1.50 cfs @ 12.26 hrs, Volume= 0.161 af, Atten= 0%, Lag= 0.0 min

Primary outflow = Inflow, Time Span= 0.00-24.00 hrs, dt= 0.05 hrs

Link DP2B: DP-2B

Hydrograph

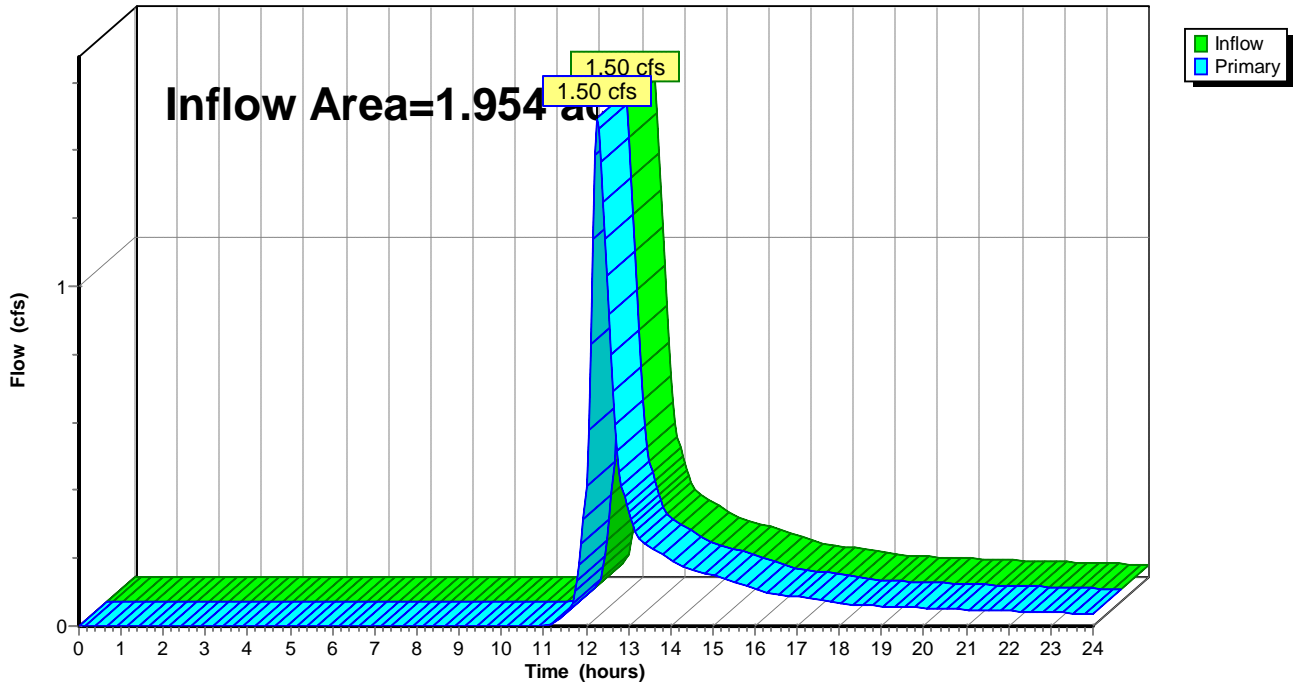

Summary for Link DP3: DP-3

Inflow Area = 9.854 ac, 38.11% Impervious, Inflow Depth > 1.35" for 2-Year event
Inflow = 1.99 cfs @ 12.10 hrs, Volume= 1.109 af
Primary = 1.99 cfs @ 12.10 hrs, Volume= 1.109 af, Atten= 0%, Lag= 0.0 min

Primary outflow = Inflow, Time Span= 0.00-24.00 hrs, dt= 0.05 hrs

Link DP3: DP-3

Hydrograph

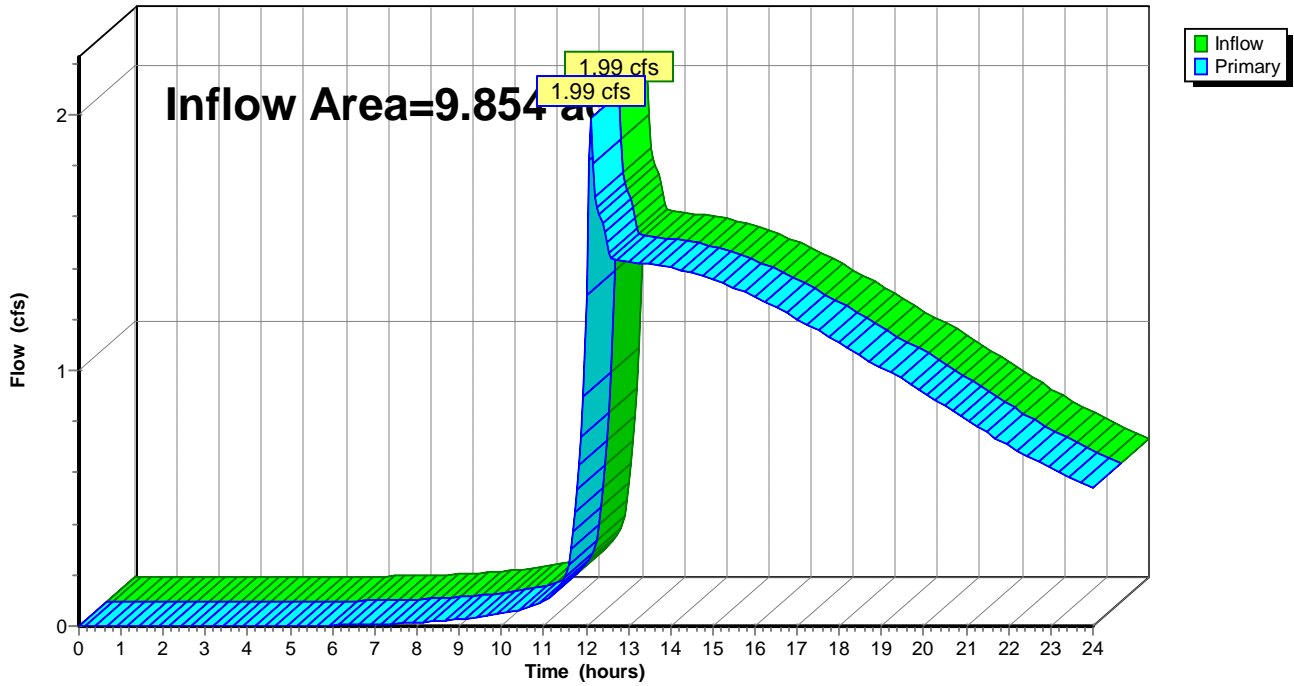

Summary for Link DP4: DP-4

Inflow Area = 0.223 ac, 20.57% Impervious, Inflow Depth > 1.41" for 2-Year event
Inflow = 0.37 cfs @ 12.08 hrs, Volume= 0.026 af
Primary = 0.37 cfs @ 12.08 hrs, Volume= 0.026 af, Atten= 0%, Lag= 0.0 min

Primary outflow = Inflow, Time Span= 0.00-24.00 hrs, dt= 0.05 hrs

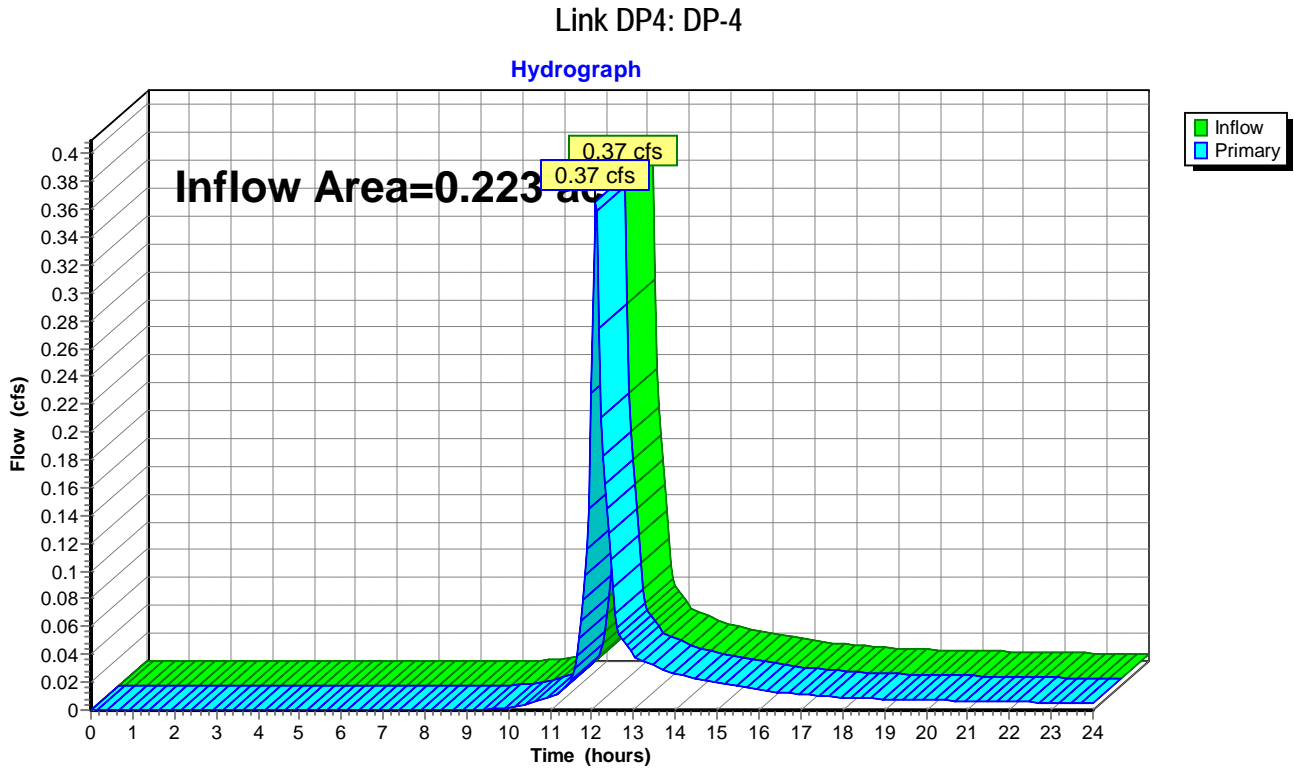

Summary for Link DP5: DP-5

Inflow Area = 1.410 ac, 22.51% Impervious, Inflow Depth > 1.41" for 2-Year event
Inflow = 2.28 cfs @ 12.09 hrs, Volume= 0.166 af
Primary = 2.28 cfs @ 12.09 hrs, Volume= 0.166 af, Atten= 0%, Lag= 0.0 min

Primary outflow = Inflow, Time Span= 0.00-24.00 hrs, dt= 0.05 hrs

Link DP5: DP-5

Hydrograph

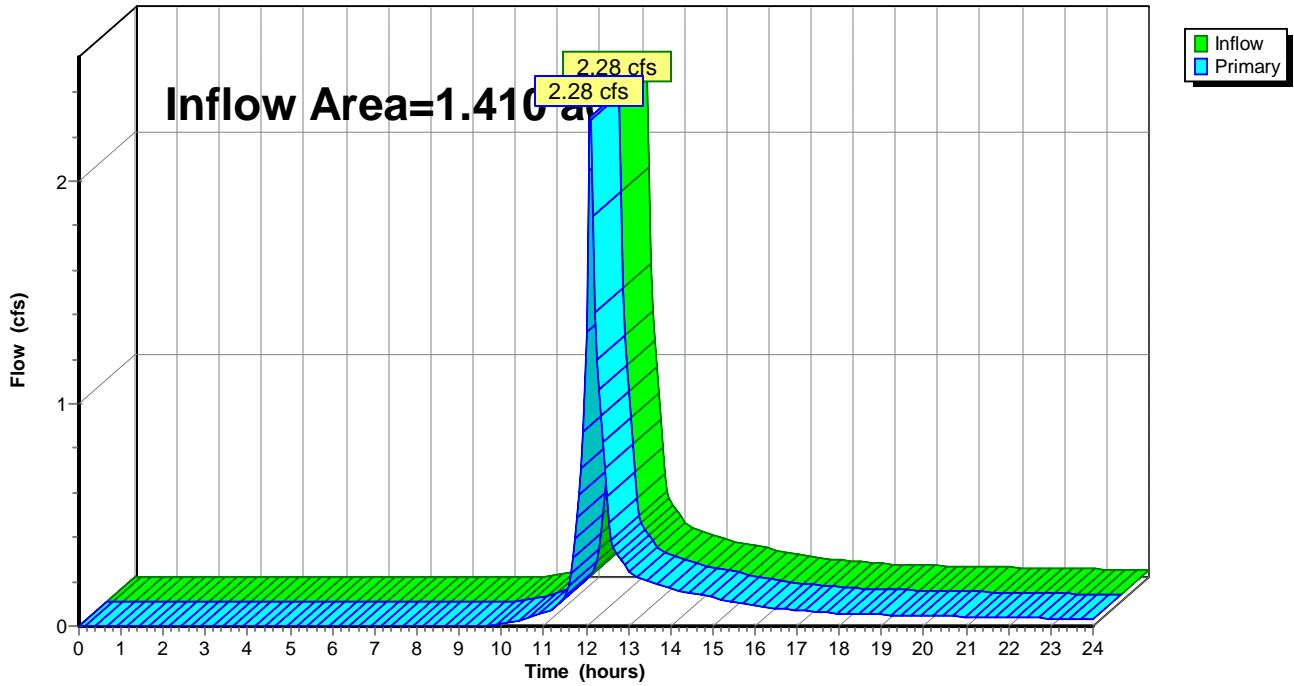

Summary for Link DP6: DP-6

Inflow Area = 1.152 ac, 19.16% Impervious, Inflow Depth > 1.41" for 2-Year event
Inflow = 1.87 cfs @ 12.09 hrs, Volume= 0.135 af
Primary = 1.87 cfs @ 12.09 hrs, Volume= 0.135 af, Atten= 0%, Lag= 0.0 min

Primary outflow = Inflow, Time Span= 0.00-24.00 hrs, dt= 0.05 hrs

Link DP6: DP-6

Hydrograph

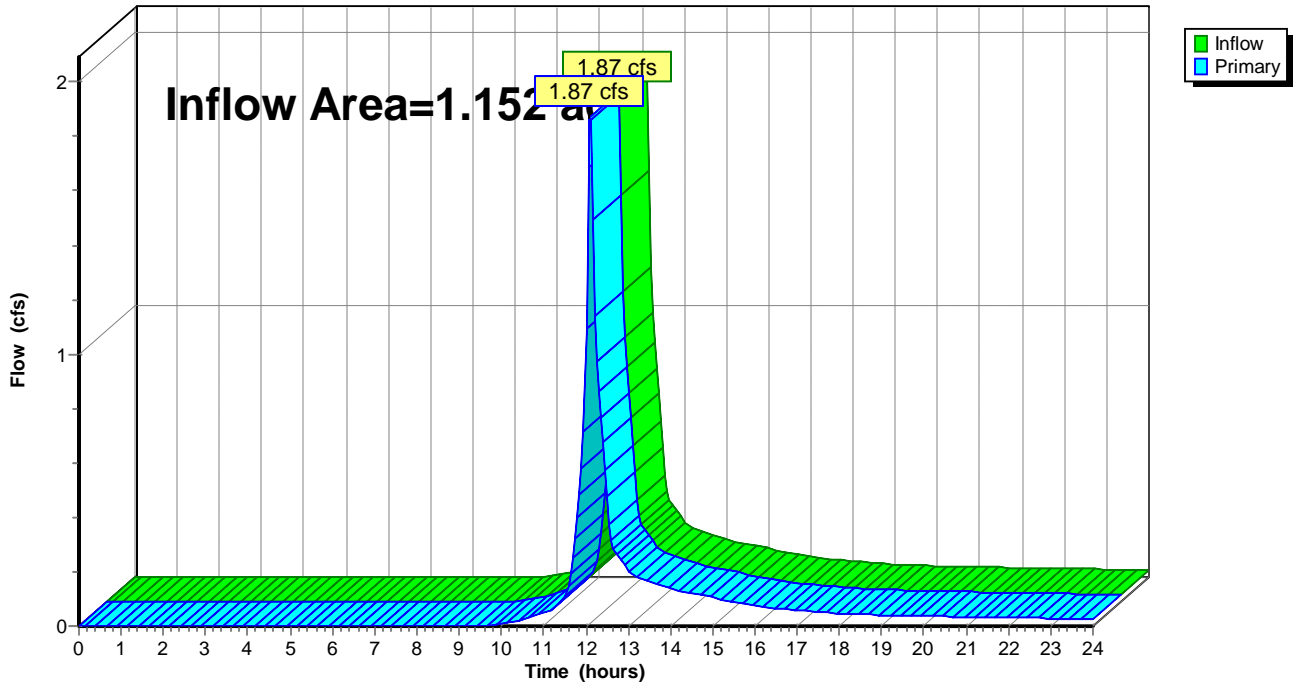

Time span=0.00-24.00 hrs, dt=0.05 hrs, 481 points
 Runoff by SCS TR-20 method, UH=SCS, Weighted-CN
 Reach routing by Stor-Ind+Trans method - Pond routing by Stor-Ind method

Subcatchment PRDA1D: PRDA-1	Runoff Area=360,934 sf 15.66% Impervious Runoff Depth>2.60" Flow Length=850' Tc=42.4 min CN=77 Runoff=12.15 cfs 1.795 af
Subcatchment PRDA1ND: PRDA-1	Runoff Area=430,511 sf 13.86% Impervious Runoff Depth>2.51" Flow Length=1,775' Tc=42.9 min CN=76 Runoff=13.89 cfs 2.069 af
Subcatchment PRDA2AND: PRDA-2A	Runoff Area=103,805 sf 0.00% Impervious Runoff Depth>2.19" Flow Length=400' Tc=24.1 min CN=72 Runoff=3.77 cfs 0.434 af
Subcatchment PRDA2BND: PRDA-2B	Runoff Area=85,134 sf 0.00% Impervious Runoff Depth>2.19" Flow Length=300' Tc=17.4 min CN=72 Runoff=3.53 cfs 0.357 af
Subcatchment PRDA3D: PRDA-3	Runoff Area=407,573 sf 36.10% Impervious Runoff Depth>3.17" Flow Length=1,450' Tc=6.7 min CN=83 Runoff=33.34 cfs 2.473 af
Subcatchment PRDA3ND: PRDA-3	Runoff Area=21,688 sf 76.07% Impervious Runoff Depth>4.09" Flow Length=100' Slope=0.1100 '/' Tc=5.0 min CN=92 Runoff=2.28 cfs 0.170 af
Subcatchment PRDA4ND: PRDA-4	Runoff Area=9,707 sf 20.57% Impervious Runoff Depth>2.80" Flow Length=100' Slope=0.1100 '/' Tc=5.0 min CN=79 Runoff=0.73 cfs 0.052 af
Subcatchment PRDA5ND: PRDA-5	Runoff Area=61,426 sf 22.51% Impervious Runoff Depth>2.80" Flow Length=300' Tc=5.7 min CN=79 Runoff=4.57 cfs 0.329 af
Subcatchment PRDA6ND: PRDA-6	Runoff Area=50,175 sf 19.16% Impervious Runoff Depth>2.80" Flow Length=650' Tc=5.6 min CN=79 Runoff=3.74 cfs 0.269 af
Pond BASIN A: BASIN A	Peak Elev=821.84' Storage=62,557 cf Inflow=33.34 cfs 2.473 af Outflow=2.06 cfs 1.804 af
Pond BASIN B: BASIN B	Peak Elev=823.28' Storage=27,284 cf Inflow=12.15 cfs 1.795 af Outflow=5.99 cfs 1.661 af
Link DP1: DP-1	Inflow=17.41 cfs 3.730 af Primary=17.41 cfs 3.730 af
Link DP2A: DP-2A	Inflow=3.77 cfs 0.434 af Primary=3.77 cfs 0.434 af
Link DP2B: DP-2B	Inflow=3.53 cfs 0.357 af Primary=3.53 cfs 0.357 af
Link DP3: DP-3	Inflow=3.59 cfs 1.974 af Primary=3.59 cfs 1.974 af
Link DP4: DP-4	Inflow=0.73 cfs 0.052 af Primary=0.73 cfs 0.052 af

Link DP5: DP-5

Inflow=4.57 cfs 0.329 af
Primary=4.57 cfs 0.329 af

Link DP6: DP-6

Inflow=3.74 cfs 0.269 af
Primary=3.74 cfs 0.269 af

Total Runoff Area = 35.146 ac Runoff Volume = 7.946 af Average Runoff Depth = 2.71"
80.06% Pervious = 28.138 ac 19.94% Impervious = 7.008 ac

Summary for Subcatchment PRDA1D: PRDA-1

Runoff = 12.15 cfs @ 12.59 hrs, Volume= 1.795 af, Depth> 2.60"

Runoff by SCS TR-20 method, UH=SCS, Weighted-CN, Time Span= 0.00-24.00 hrs, dt= 0.05 hrs
 Type III 24-hr 10-Year Rainfall=5.00"

Area (sf)	CN	Description
36,718	98	Impervious, HSG C
1,151	98	Roofs, HSG C
18,667	98	Water Surface, HSG C
124,441	74	Pasture/grassland/range, Good, HSG C
* 115,820	75	Gravel, HSG C
64,137	70	Woods, Good, HSG C
360,934	77	Weighted Average
304,398		84.34% Pervious Area
56,536		15.66% Impervious Area

Tc (min)	Length (feet)	Slope (ft/ft)	Velocity (ft/sec)	Capacity (cfs)	Description
37.0	250	0.0320	0.11		Sheet Flow, Woods: Light underbrush n= 0.400 P2= 3.20"
5.4	600	0.0700	1.85		Shallow Concentrated Flow, Short Grass Pasture Kv= 7.0 fps
42.4	850	Total			

Subcatchment PRDA1D: PRDA-1

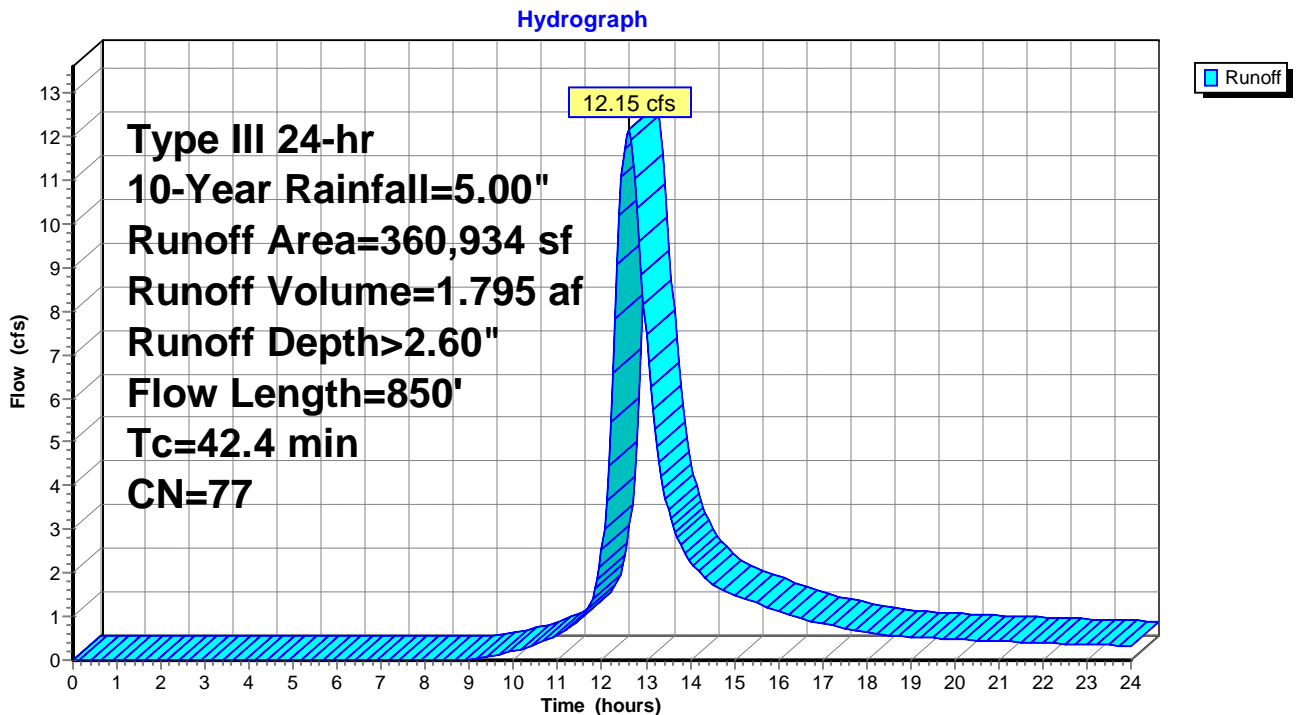

Summary for Subcatchment PRDA1ND: PRDA-1

Runoff = 13.89 cfs @ 12.60 hrs, Volume= 2.069 af, Depth> 2.51"

Runoff by SCS TR-20 method, UH=SCS, Weighted-CN, Time Span= 0.00-24.00 hrs, dt= 0.05 hrs
 Type III 24-hr 10-Year Rainfall=5.00"

Area (sf)	CN	Description
114,584	70	Woods, Good, HSG C
256,245	74	Pasture/grassland/range, Good, HSG C
59,682	98	Impervious, HSG C
430,511	76	Weighted Average
370,829		86.14% Pervious Area
59,682		13.86% Impervious Area

Tc (min)	Length (feet)	Slope (ft/ft)	Velocity (ft/sec)	Capacity (cfs)	Description
37.0	250	0.0320	0.11		Sheet Flow, Woods: Light underbrush n= 0.400 P2= 3.20"
4.9	1,000	0.0440	3.38		Shallow Concentrated Flow, Unpaved Kv= 16.1 fps
1.0	525	0.0570	8.87	53.22	Channel Flow, Area= 6.0 sf Perim= 6.0' r= 1.00' n= 0.040 Earth, cobble bottom, clean sides

42.9 1,775 Total

Subcatchment PRDA1ND: PRDA-1

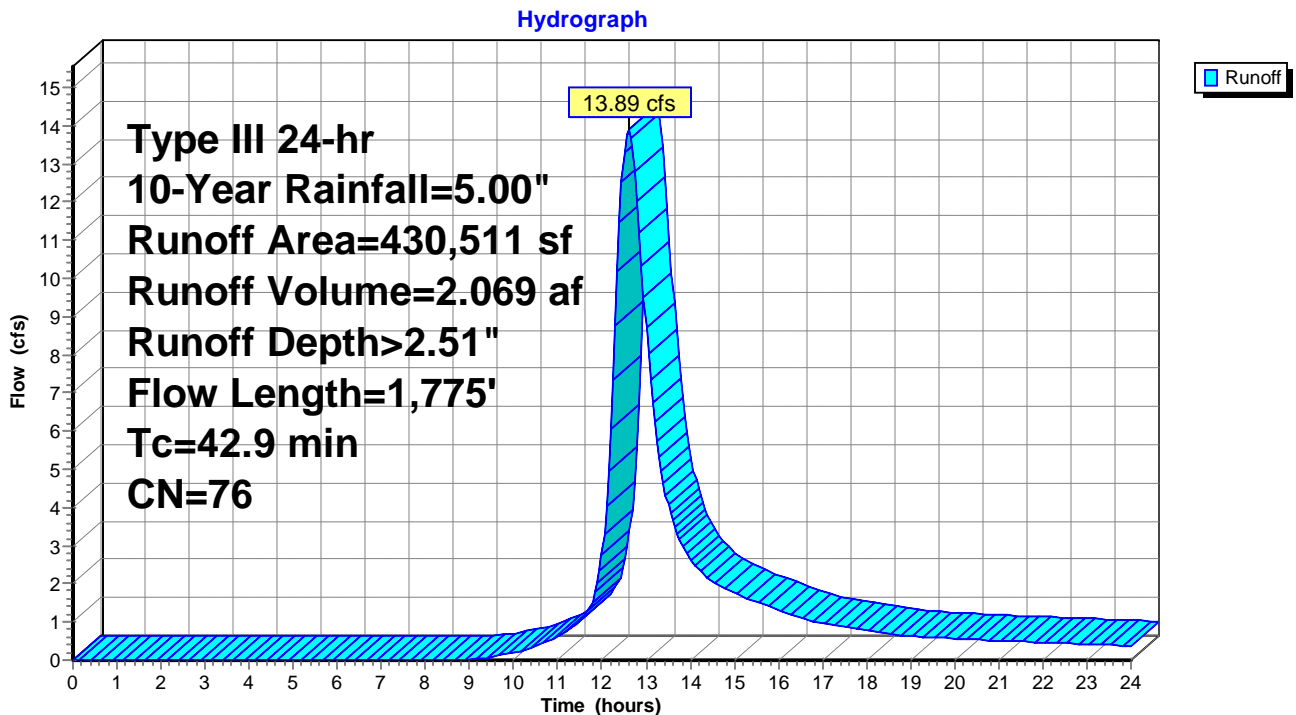

Summary for Subcatchment PRDA2AND: PRDA-2A

Runoff = 3.77 cfs @ 12.35 hrs, Volume= 0.434 af, Depth> 2.19"

Runoff by SCS TR-20 method, UH=SCS, Weighted-CN, Time Span= 0.00-24.00 hrs, dt= 0.05 hrs
 Type III 24-hr 10-Year Rainfall=5.00"

Area (sf)	CN	Description
46,490	70	Woods, Good, HSG C
57,315	74	Pasture/grassland/range, Good, HSG C
103,805	72	Weighted Average
103,805		100.00% Pervious Area

Tc (min)	Length (feet)	Slope (ft/ft)	Velocity (ft/sec)	Capacity (cfs)	Description
23.1	250	0.1040	0.18		Sheet Flow, Woods: Light underbrush n= 0.400 P2= 3.20"
1.0	150	0.2400	2.45		Shallow Concentrated Flow, Woodland Kv= 5.0 fps
24.1	400	Total			

Subcatchment PRDA2AND: PRDA-2A

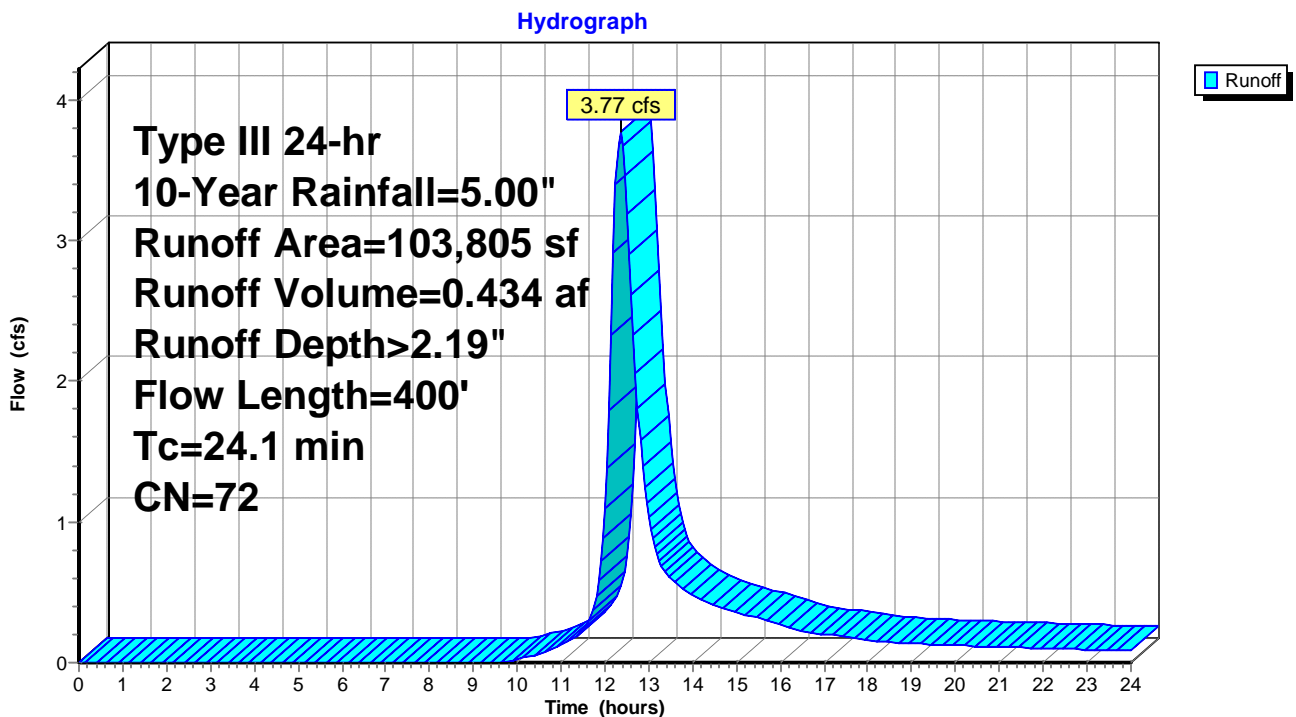

Summary for Subcatchment PRDA2BND: PRDA-2B

Runoff = 3.53 cfs @ 12.25 hrs, Volume= 0.357 af, Depth> 2.19"

Runoff by SCS TR-20 method, UH=SCS, Weighted-CN, Time Span= 0.00-24.00 hrs, dt= 0.05 hrs
 Type III 24-hr 10-Year Rainfall=5.00"

Area (sf)	CN	Description
33,200	70	Woods, Good, HSG C
51,934	74	Pasture/grassland/range, Good, HSG C
85,134	72	Weighted Average
85,134		100.00% Pervious Area

Tc (min)	Length (feet)	Slope (ft/ft)	Velocity (ft/sec)	Capacity (cfs)	Description
16.1	200	0.1650	0.21		Sheet Flow, Woods: Light underbrush n= 0.400 P2= 3.20"
1.3	100	0.0700	1.32		Shallow Concentrated Flow, Woodland Kv= 5.0 fps
17.4	300	Total			

Subcatchment PRDA2BND: PRDA-2B

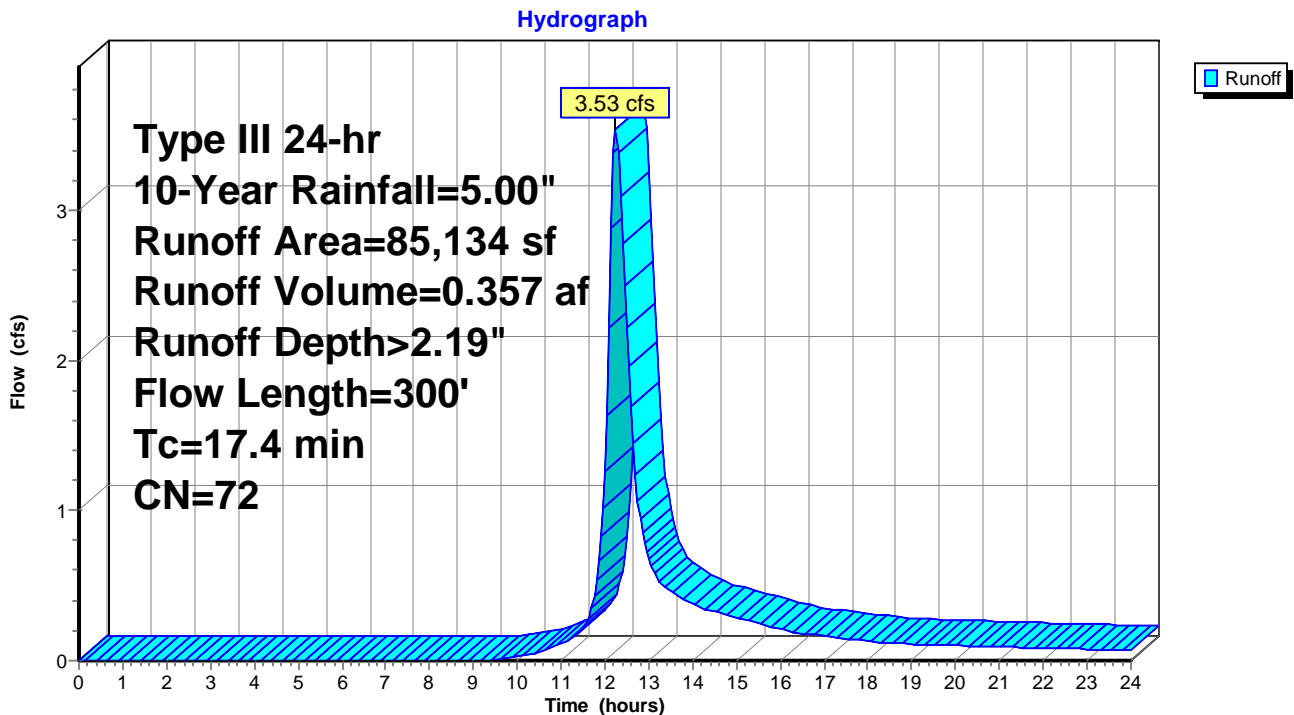

Summary for Subcatchment PRDA3D: PRDA-3

Runoff = 33.34 cfs @ 12.10 hrs, Volume= 2.473 af, Depth> 3.17"

Runoff by SCS TR-20 method, UH=SCS, Weighted-CN, Time Span= 0.00-24.00 hrs, dt= 0.05 hrs
 Type III 24-hr 10-Year Rainfall=5.00"

Area (sf)	CN	Description
69,087	98	Impervious, HSG C
36,569	98	Roofs, HSG C
41,458	98	Water Surface, HSG C
* 260,459	75	Gravel, HSG C
407,573	83	Weighted Average
260,459		63.90% Pervious Area
147,114		36.10% Impervious Area

Tc (min)	Length (feet)	Slope (ft/ft)	Velocity (ft/sec)	Capacity (cfs)	Description
3.3	250	0.0100	1.25		Sheet Flow, Smooth surfaces n= 0.011 P2= 3.20"
3.4	1,200	0.0075	5.93	7.27	Pipe Channel, 15.0" Round Area= 1.2 sf Perim= 3.9' r= 0.31' n= 0.010 PVC, smooth interior
6.7	1,450	Total			

Subcatchment PRDA3D: PRDA-3

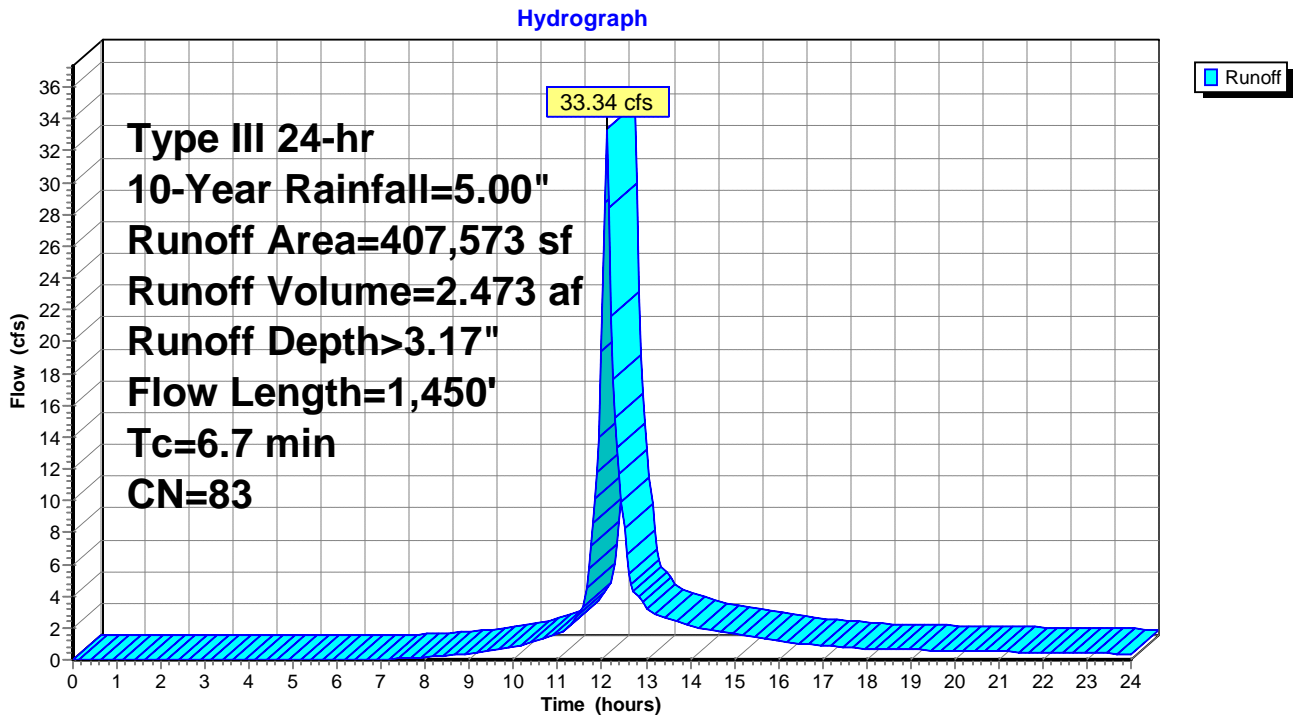

Summary for Subcatchment PRDA3ND: PRDA-3

Runoff = 2.28 cfs @ 12.07 hrs, Volume= 0.170 af, Depth> 4.09"

Runoff by SCS TR-20 method, UH=SCS, Weighted-CN, Time Span= 0.00-24.00 hrs, dt= 0.05 hrs
 Type III 24-hr 10-Year Rainfall=5.00"

Area (sf)	CN	Description
5,191	74	Pasture/grassland/range, Good, HSG C
16,497	98	Impervious, HSG C
21,688	92	Weighted Average
5,191		23.93% Pervious Area
16,497		76.07% Impervious Area

Tc (min)	Length (feet)	Slope (ft/ft)	Velocity (ft/sec)	Capacity (cfs)	Description
5.0	100	0.1100	0.34		Sheet Flow, Grass: Short n= 0.150 P2= 3.20"

Subcatchment PRDA3ND: PRDA-3

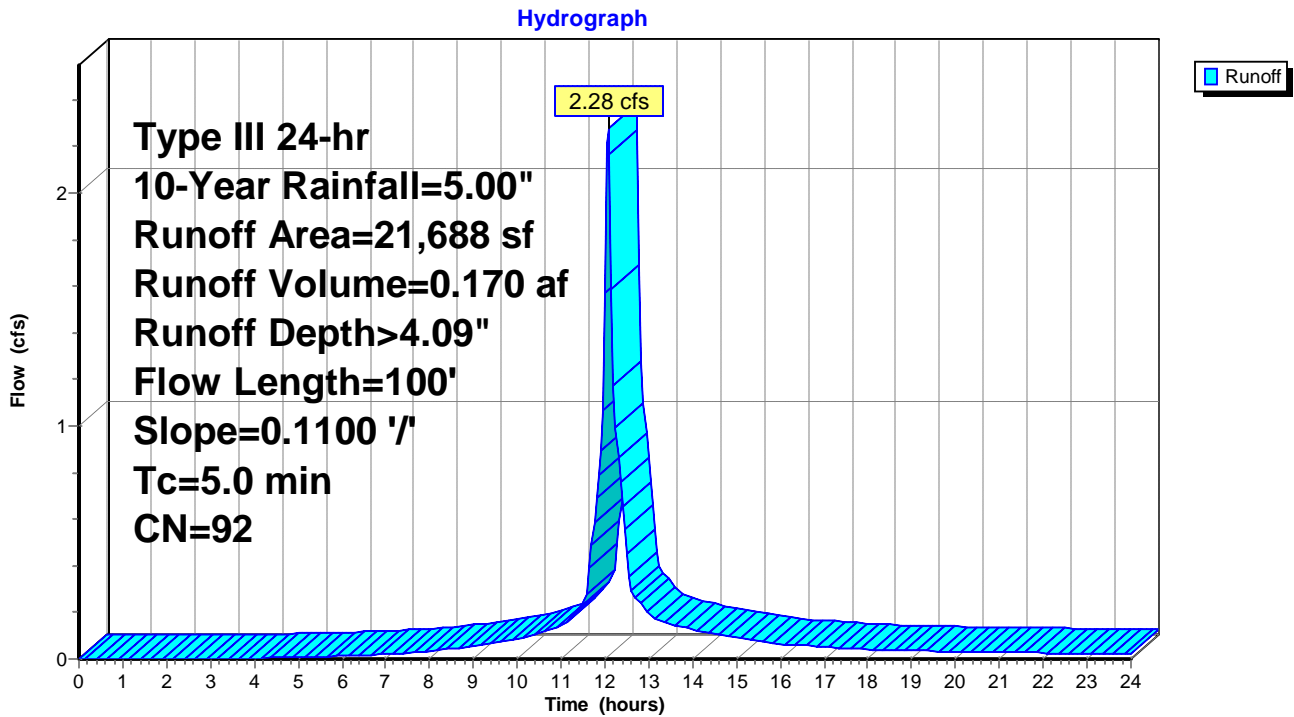

Summary for Subcatchment PRDA4ND: PRDA-4

Runoff = 0.73 cfs @ 12.08 hrs, Volume= 0.052 af, Depth> 2.80"

Runoff by SCS TR-20 method, UH=SCS, Weighted-CN, Time Span= 0.00-24.00 hrs, dt= 0.05 hrs
 Type III 24-hr 10-Year Rainfall=5.00"

Area (sf)	CN	Description
7,710	74	Pasture/grassland/range, Good, HSG C
* 1,997	98	Impervious
9,707	79	Weighted Average
7,710		79.43% Pervious Area
1,997		20.57% Impervious Area

Tc (min)	Length (feet)	Slope (ft/ft)	Velocity (ft/sec)	Capacity (cfs)	Description
5.0	100	0.1100	0.34		Sheet Flow, Grass: Short n= 0.150 P2= 3.20"

Subcatchment PRDA4ND: PRDA-4

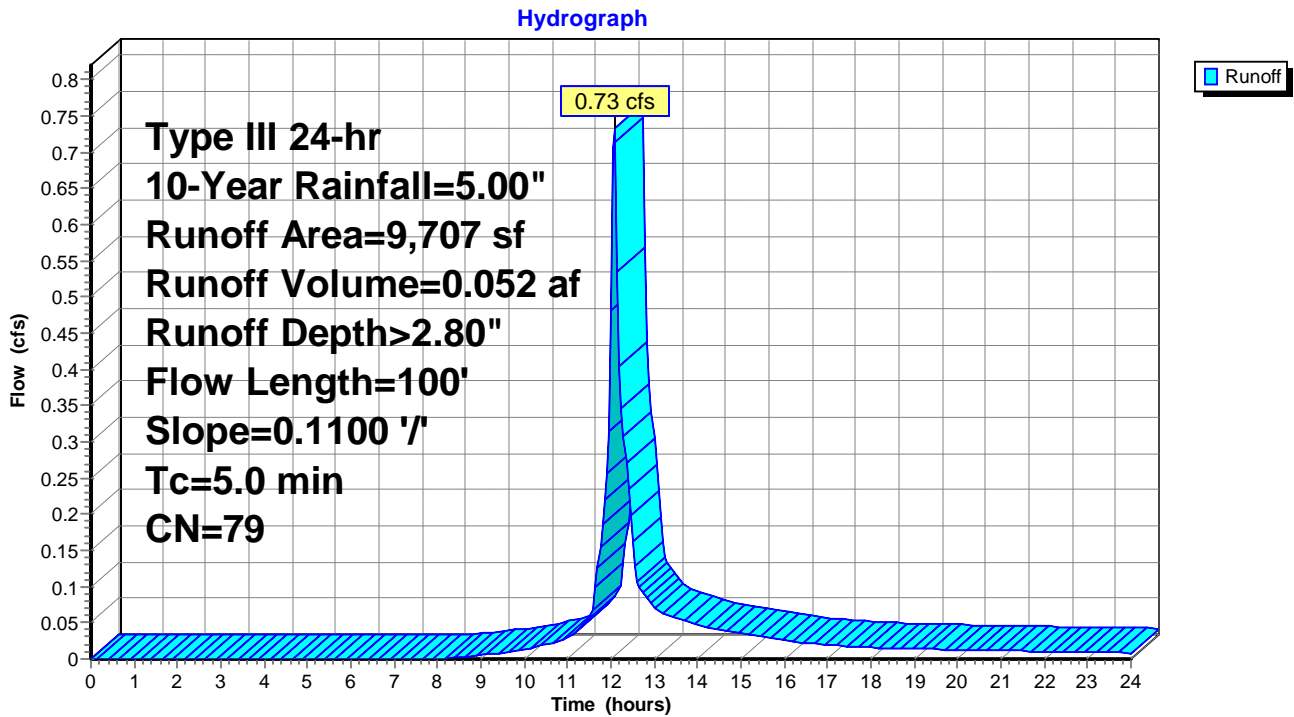

Summary for Subcatchment PRDA5ND: PRDA-5

Runoff = 4.57 cfs @ 12.09 hrs, Volume= 0.329 af, Depth> 2.80"

Runoff by SCS TR-20 method, UH=SCS, Weighted-CN, Time Span= 0.00-24.00 hrs, dt= 0.05 hrs
 Type III 24-hr 10-Year Rainfall=5.00"

Area (sf)	CN	Description
13,824	98	Impervious, HSG C
47,602	74	Pasture/grassland/range, Good, HSG C
61,426	79	Weighted Average
47,602		77.49% Pervious Area
13,824		22.51% Impervious Area

Tc (min)	Length (feet)	Slope (ft/ft)	Velocity (ft/sec)	Capacity (cfs)	Description
5.5	200	0.3333	0.60		Sheet Flow, Grass: Short n= 0.150 P2= 3.20"
0.2	100	0.0100	6.84	8.40	Pipe Channel, 15.0" Round Area= 1.2 sf Perim= 3.9' r= 0.31' n= 0.010 PVC, smooth interior
5.7	300	Total			

Subcatchment PRDA5ND: PRDA-5

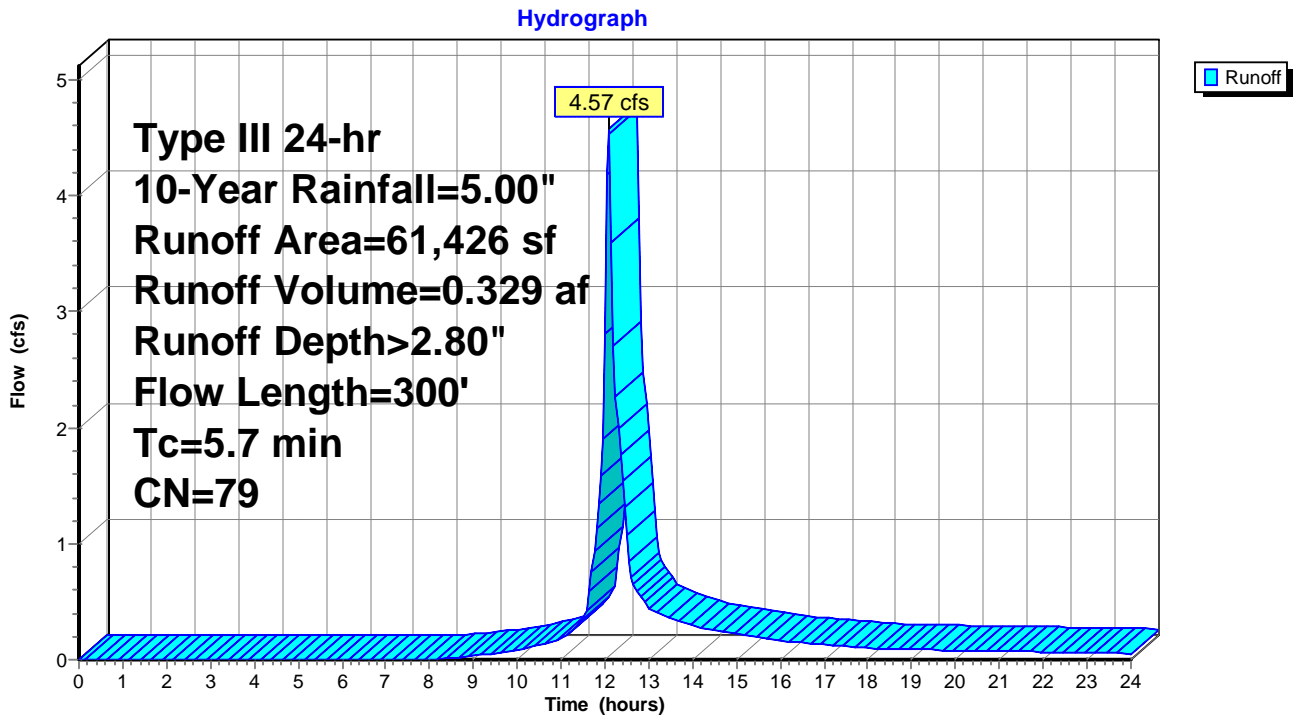

Summary for Subcatchment PRDA6ND: PRDA-6

Runoff = 3.74 cfs @ 12.09 hrs, Volume= 0.269 af, Depth> 2.80"

Runoff by SCS TR-20 method, UH=SCS, Weighted-CN, Time Span= 0.00-24.00 hrs, dt= 0.05 hrs
 Type III 24-hr 10-Year Rainfall=5.00"

Area (sf)	CN	Description
40,563	74	Pasture/grassland/range, Good, HSG C
9,612	98	Impervious, HSG C
50,175	79	Weighted Average
40,563		80.84% Pervious Area
9,612		19.16% Impervious Area

Tc (min)	Length (feet)	Slope (ft/ft)	Velocity (ft/sec)	Capacity (cfs)	Description
4.4	150	0.3333	0.57		Sheet Flow, Grass: Short n= 0.150 P2= 3.20"
1.2	500	0.2050	6.79		Shallow Concentrated Flow, Grassed Waterway Kv= 15.0 fps
5.6	650	Total			

Subcatchment PRDA6ND: PRDA-6

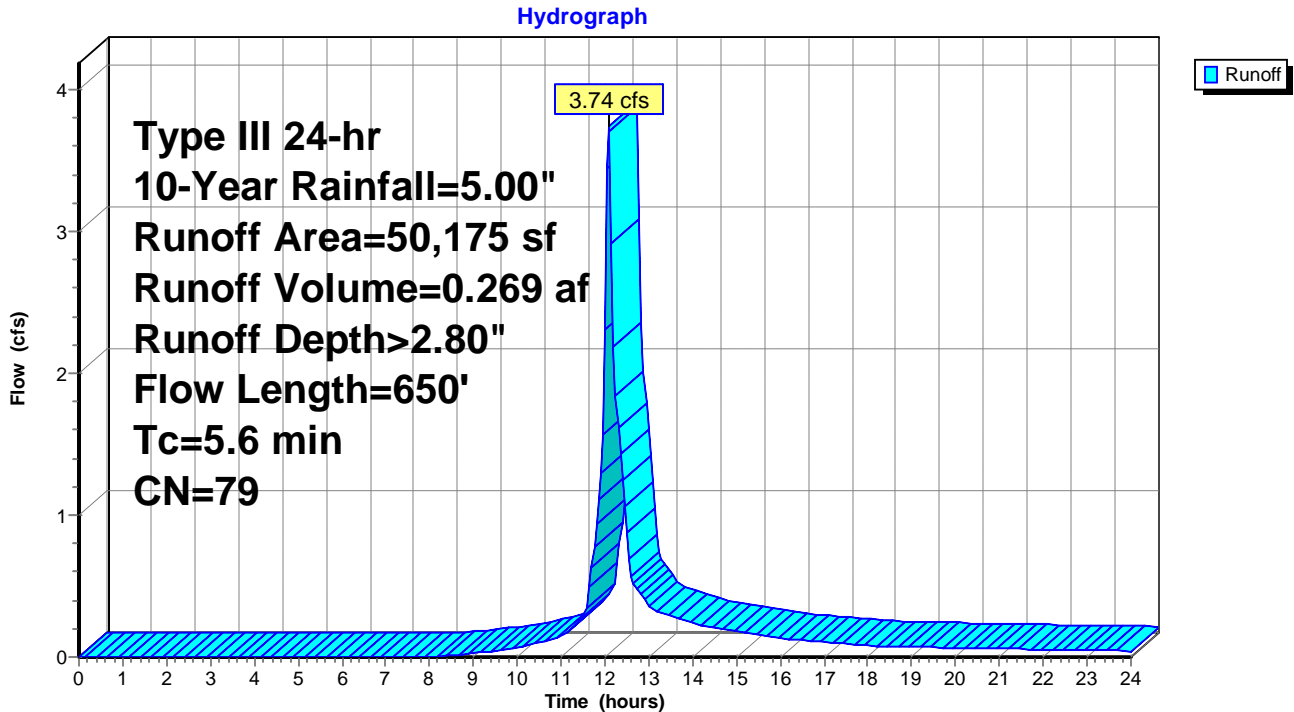

Summary for Pond BASIN A: BASIN A

Inflow Area = 9.357 ac, 36.10% Impervious, Inflow Depth > 3.17" for 10-Year event
 Inflow = 33.34 cfs @ 12.10 hrs, Volume= 2.473 af
 Outflow = 2.06 cfs @ 14.05 hrs, Volume= 1.804 af, Atten= 94%, Lag= 117.3 min
 Primary = 2.06 cfs @ 14.05 hrs, Volume= 1.804 af

Routing by Stor-Ind method, Time Span= 0.00-24.00 hrs, dt= 0.05 hrs
 Peak Elev= 821.84' @ 14.05 hrs Surf.Area= 37,276 sf Storage= 62,557 cf

Plug-Flow detention time= 321.2 min calculated for 1.800 af (73% of inflow)
 Center-of-Mass det. time= 232.4 min (1,045.9 - 813.5)

Volume	Invert	Avail.Storage	Storage Description
#1	820.00'	151,470 cf	Basin A (Irregular) Listed below (Recalc)

Elevation (feet)	Surf.Area (sq-ft)	Perim. (feet)	Inc.Store (cubic-feet)	Cum.Store (cubic-feet)	Wet.Area (sq-ft)
820.00	30,856	1,150.0	0	0	30,856
822.00	37,867	1,187.0	68,603	68,603	38,123
824.00	45,105	1,225.0	82,867	151,470	45,805

Device	Routing	Invert	Outlet Devices
#1	Primary	820.00'	15.0" Round Culvert L= 250.0' Ke= 0.500 Inlet / Outlet Invert= 820.00' / 786.00' S= 0.1360 '/' Cc= 0.900 n= 0.010 PVC, smooth interior, Flow Area= 1.23 sf
#2	Device 1	820.00'	8.0" Vert. Orifice/Grate C= 0.600
#3	Device 1	822.00'	15.0" W x 12.0" H Vert. Orifice/Grate X 2.00 C= 0.600

Primary OutFlow Max=2.06 cfs @ 14.05 hrs HW=821.84' (Free Discharge)

- 1=Culvert (Passes 2.06 cfs of 6.51 cfs potential flow)
- 2=Orifice/Grate (Orifice Controls 2.06 cfs @ 5.91 fps)
- 3=Orifice/Grate (Controls 0.00 cfs)

Pond BASIN A: BASIN A

Hydrograph

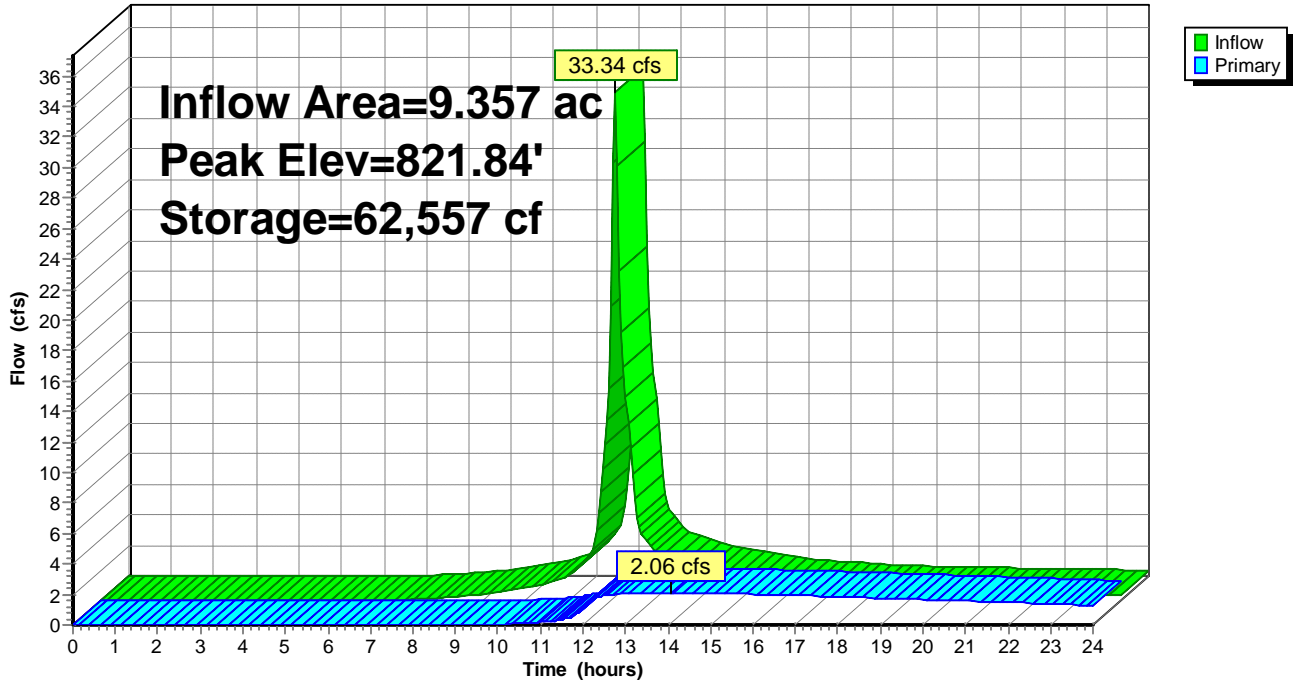

Summary for Pond BASIN B: BASIN B

Inflow Area = 8.286 ac, 15.66% Impervious, Inflow Depth > 2.60" for 10-Year event
 Inflow = 12.15 cfs @ 12.59 hrs, Volume= 1.795 af
 Outflow = 5.99 cfs @ 13.13 hrs, Volume= 1.661 af, Atten= 51%, Lag= 32.1 min
 Primary = 5.99 cfs @ 13.13 hrs, Volume= 1.661 af

Routing by Stor-Ind method, Time Span= 0.00-24.00 hrs, dt= 0.05 hrs
 Peak Elev= 823.28' @ 13.13 hrs Surf.Area= 14,536 sf Storage= 27,284 cf

Plug-Flow detention time= 121.4 min calculated for 1.661 af (93% of inflow)
 Center-of-Mass det. time= 84.9 min (943.0 - 858.0)

Volume	Invert	Avail.Storage	Storage Description		
#1	821.00'	122,878 cf	Basin B (Irregular) Listed below (Recalc)		
Elevation (feet)	Surf.Area (sq-ft)	Perim. (feet)	Inc.Store (cubic-feet)	Cum.Store (cubic-feet)	Wet.Area (sq-ft)
821.00	9,468	729.0	0	0	9,468
822.00	11,682	748.0	10,556	10,556	11,820
824.00	16,283	786.0	27,838	38,394	16,706
826.00	21,113	824.1	37,292	75,685	21,846
828.00	26,170	850.0	47,193	122,878	25,681

Device	Routing	Invert	Outlet Devices	
#1	Primary	821.00'	18.0" Round Culvert L= 100.0' Ke= 0.500 Inlet / Outlet Invert= 821.00' / 797.00' S= 0.2400 '/' Cc= 0.900 n= 0.010 PVC, smooth interior, Flow Area= 1.77 sf	
#2	Device 1	821.00'	6.0" Vert. Orifice/Grate C= 0.600	
#3	Device 1	822.00'	12.0" W x 30.0" H Vert. Orifice/Grate C= 0.600	
#4	Primary	825.00'	24.0" Vert. Orifice/Grate C= 0.600	

Primary OutFlow Max=5.98 cfs @ 13.13 hrs HW=823.28' (Free Discharge)

- 1=Culvert (Passes 5.98 cfs of 10.52 cfs potential flow)
- 2=Orifice/Grate (Orifice Controls 1.35 cfs @ 6.86 fps)
- 3=Orifice/Grate (Orifice Controls 4.64 cfs @ 3.63 fps)
- 4=Orifice/Grate (Controls 0.00 cfs)

Pond BASIN B: BASIN B

Hydrograph

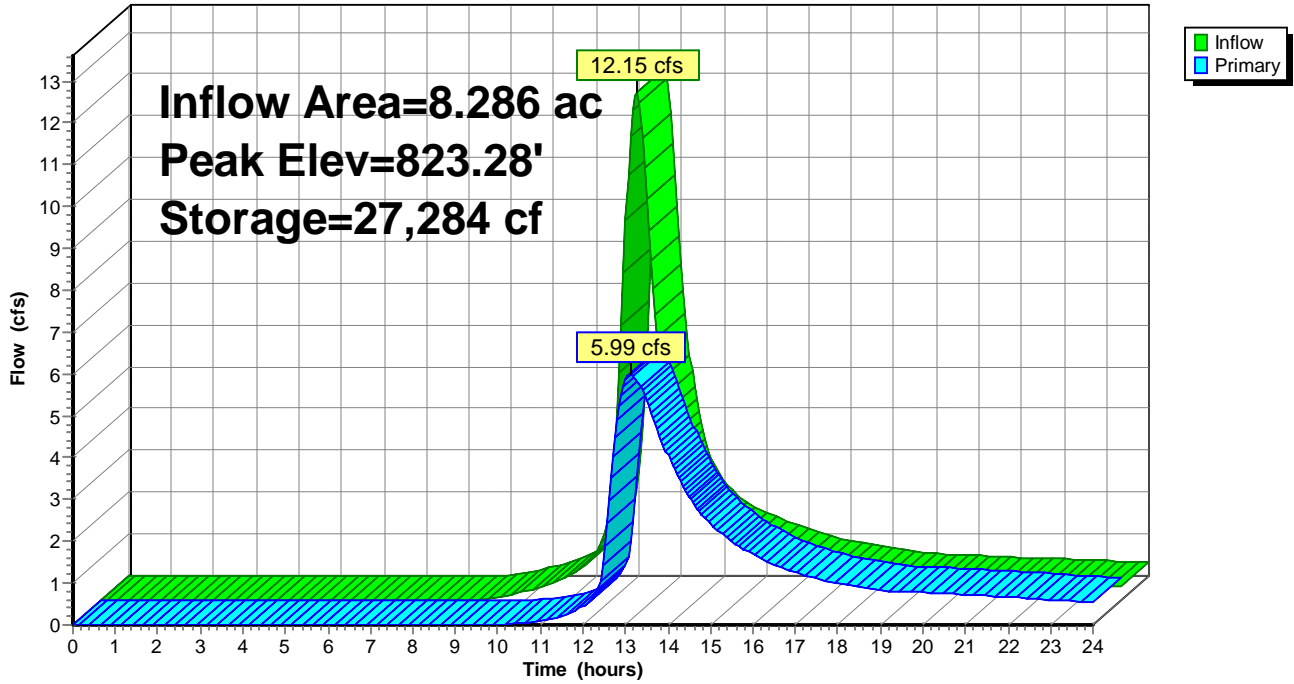

Summary for Link DP1: DP-1

Inflow Area = 18.169 ac, 14.68% Impervious, Inflow Depth > 2.46" for 10-Year event
Inflow = 17.41 cfs @ 12.70 hrs, Volume= 3.730 af
Primary = 17.41 cfs @ 12.70 hrs, Volume= 3.730 af, Atten= 0%, Lag= 0.0 min

Primary outflow = Inflow, Time Span= 0.00-24.00 hrs, dt= 0.05 hrs

Link DP1: DP-1

Hydrograph

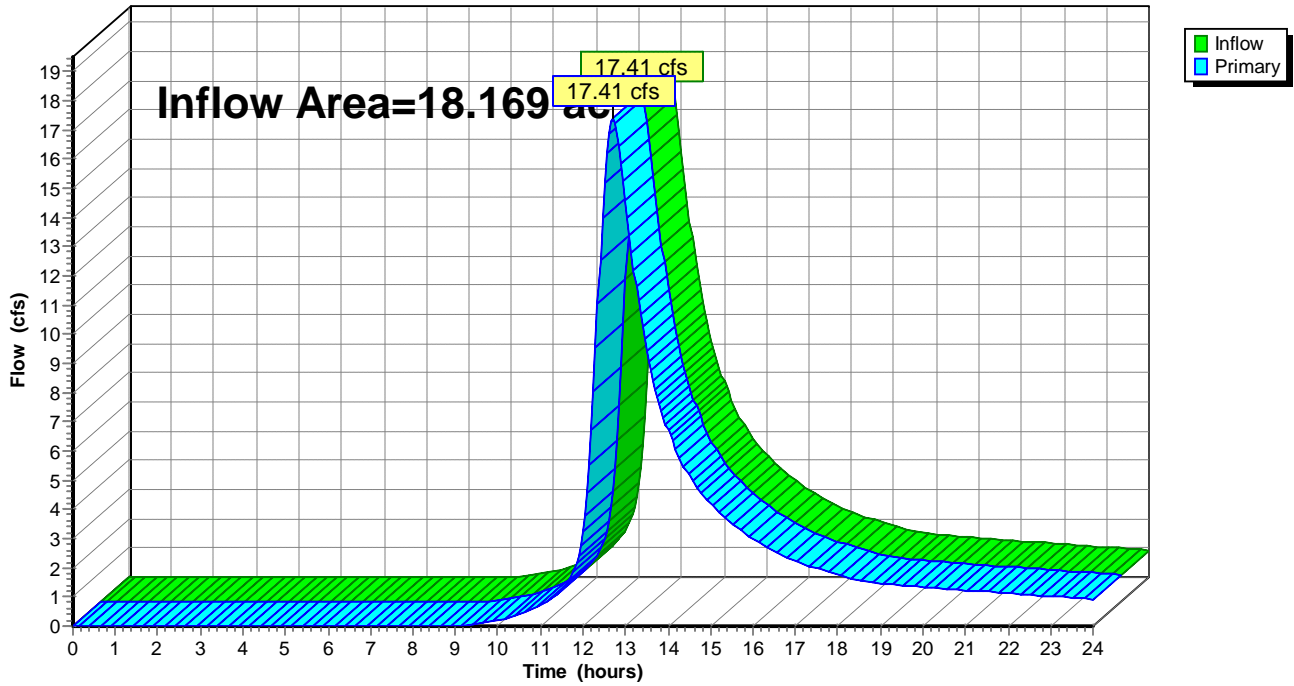

Summary for Link DP2A: DP-2A

Inflow Area = 2.383 ac, 0.00% Impervious, Inflow Depth > 2.19" for 10-Year event
Inflow = 3.77 cfs @ 12.35 hrs, Volume= 0.434 af
Primary = 3.77 cfs @ 12.35 hrs, Volume= 0.434 af, Atten= 0%, Lag= 0.0 min

Primary outflow = Inflow, Time Span= 0.00-24.00 hrs, dt= 0.05 hrs

Link DP2A: DP-2A

Hydrograph

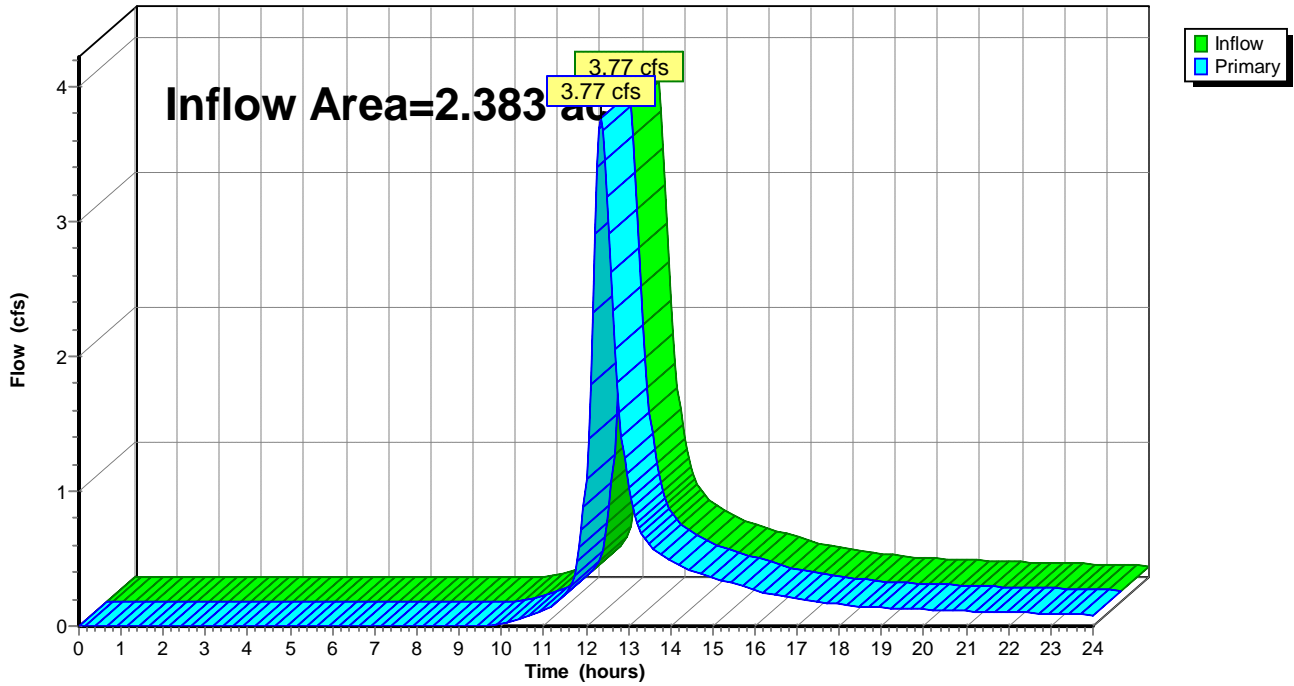

Summary for Link DP2B: DP-2B

Inflow Area = 1.954 ac, 0.00% Impervious, Inflow Depth > 2.19" for 10-Year event
Inflow = 3.53 cfs @ 12.25 hrs, Volume= 0.357 af
Primary = 3.53 cfs @ 12.25 hrs, Volume= 0.357 af, Atten= 0%, Lag= 0.0 min

Primary outflow = Inflow, Time Span= 0.00-24.00 hrs, dt= 0.05 hrs

Link DP2B: DP-2B

Hydrograph

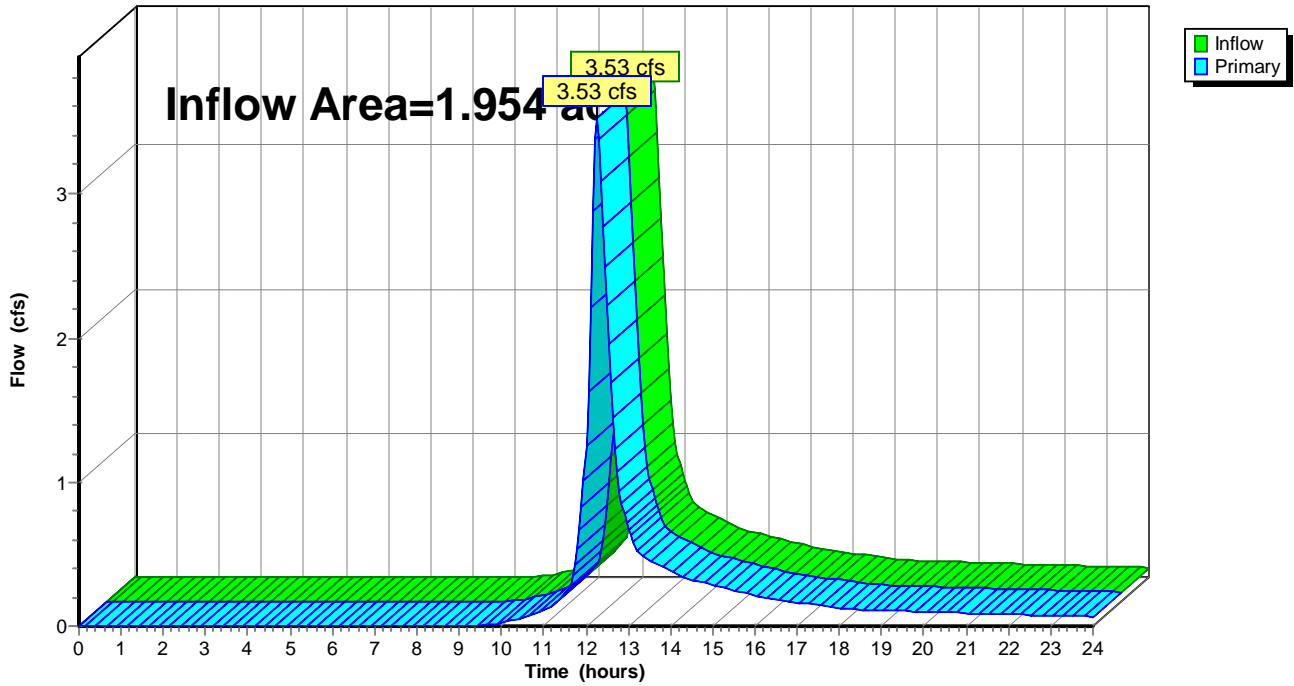

Summary for Link DP3: DP-3

Inflow Area = 9.854 ac, 38.11% Impervious, Inflow Depth > 2.40" for 10-Year event
Inflow = 3.59 cfs @ 12.09 hrs, Volume= 1.974 af
Primary = 3.59 cfs @ 12.09 hrs, Volume= 1.974 af, Atten= 0%, Lag= 0.0 min

Primary outflow = Inflow, Time Span= 0.00-24.00 hrs, dt= 0.05 hrs

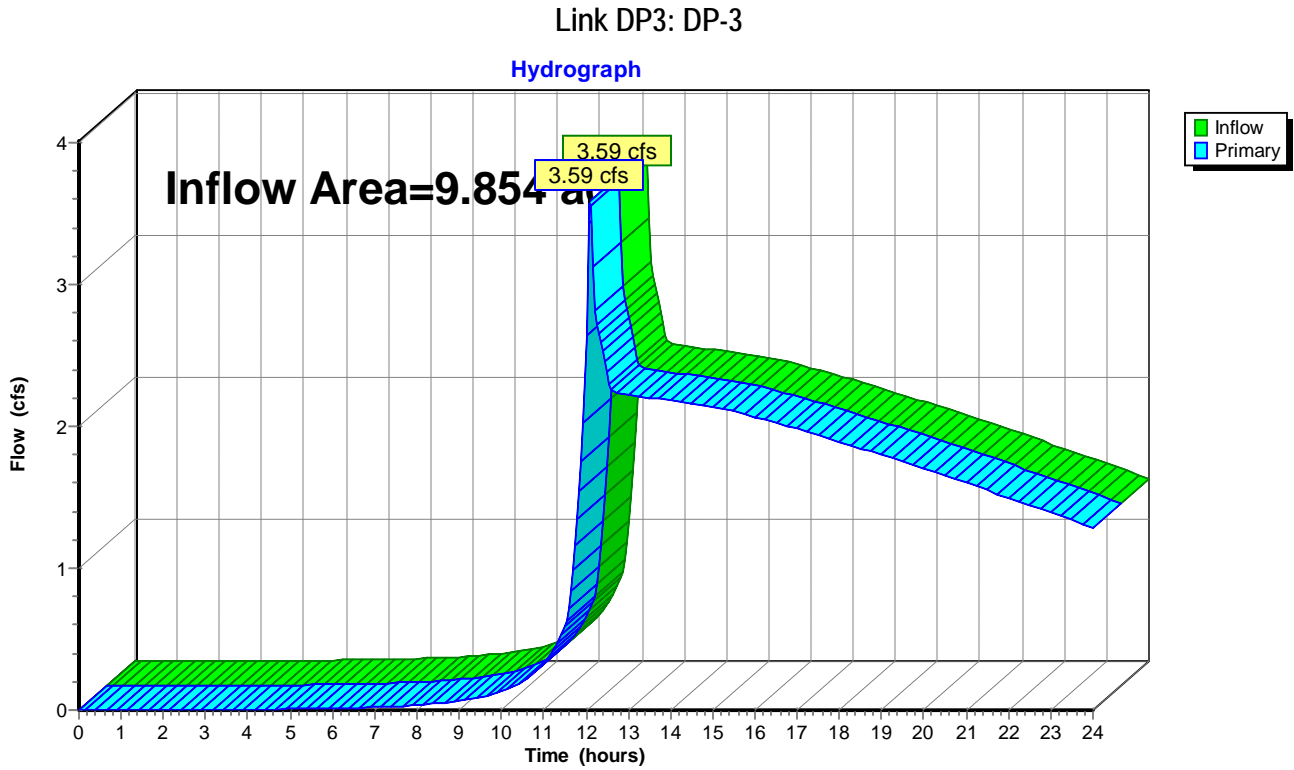

Summary for Link DP4: DP-4

Inflow Area = 0.223 ac, 20.57% Impervious, Inflow Depth > 2.80" for 10-Year event
Inflow = 0.73 cfs @ 12.08 hrs, Volume= 0.052 af
Primary = 0.73 cfs @ 12.08 hrs, Volume= 0.052 af, Atten= 0%, Lag= 0.0 min

Primary outflow = Inflow, Time Span= 0.00-24.00 hrs, dt= 0.05 hrs

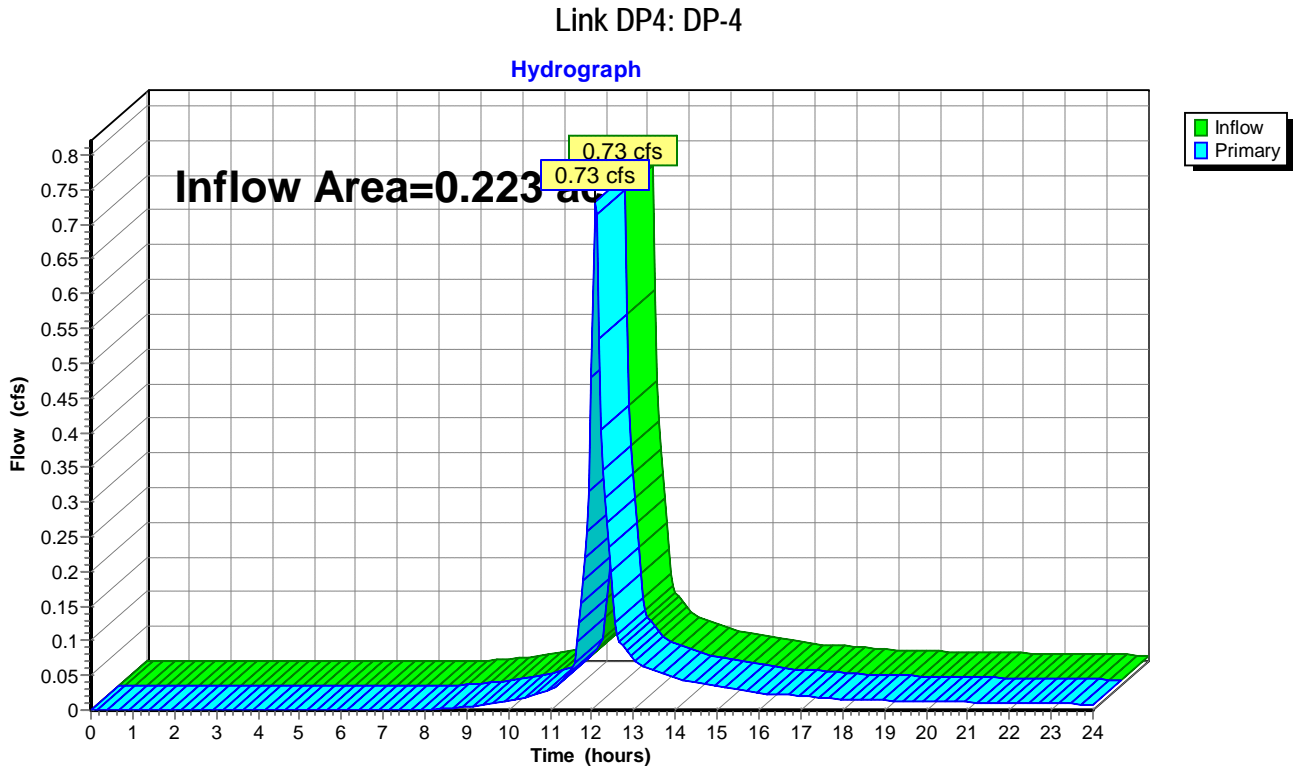

Summary for Link DP5: DP-5

Inflow Area = 1.410 ac, 22.51% Impervious, Inflow Depth > 2.80" for 10-Year event
Inflow = 4.57 cfs @ 12.09 hrs, Volume= 0.329 af
Primary = 4.57 cfs @ 12.09 hrs, Volume= 0.329 af, Atten= 0%, Lag= 0.0 min

Primary outflow = Inflow, Time Span= 0.00-24.00 hrs, dt= 0.05 hrs

Link DP5: DP-5

Hydrograph

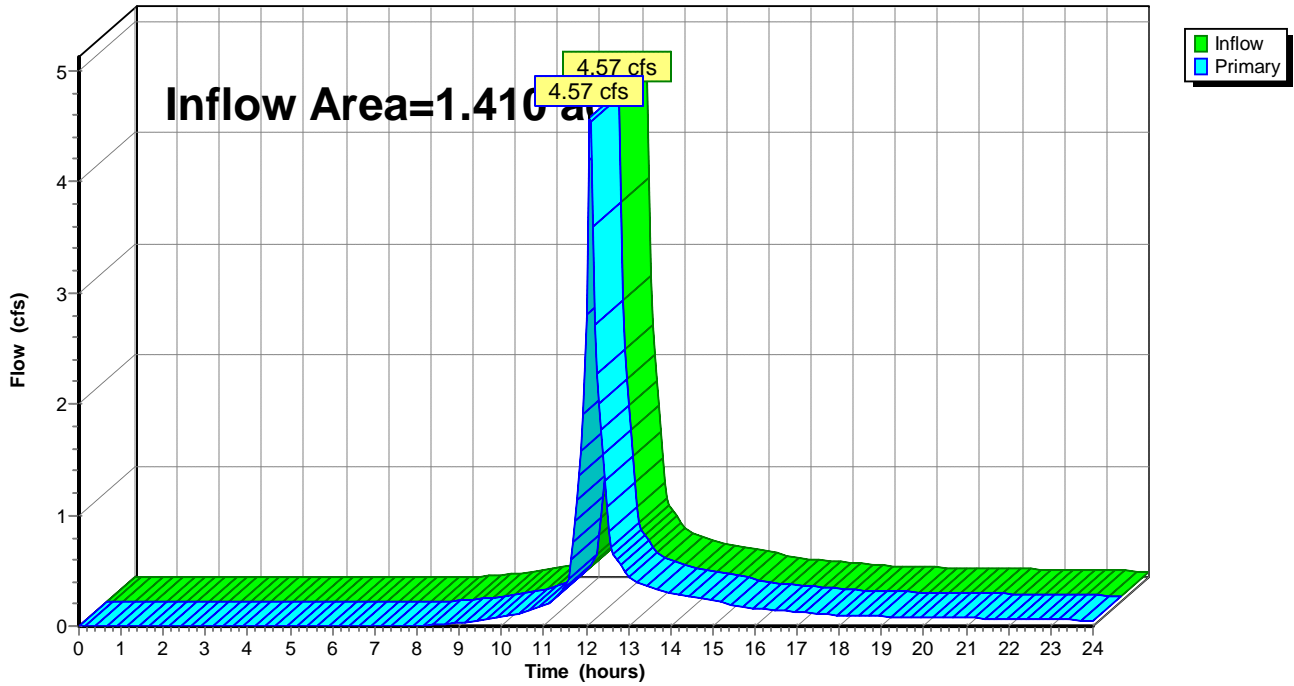

Summary for Link DP6: DP-6

Inflow Area = 1.152 ac, 19.16% Impervious, Inflow Depth > 2.80" for 10-Year event
Inflow = 3.74 cfs @ 12.09 hrs, Volume= 0.269 af
Primary = 3.74 cfs @ 12.09 hrs, Volume= 0.269 af, Atten= 0%, Lag= 0.0 min

Primary outflow = Inflow, Time Span= 0.00-24.00 hrs, dt= 0.05 hrs

Link DP6: DP-6

Hydrograph

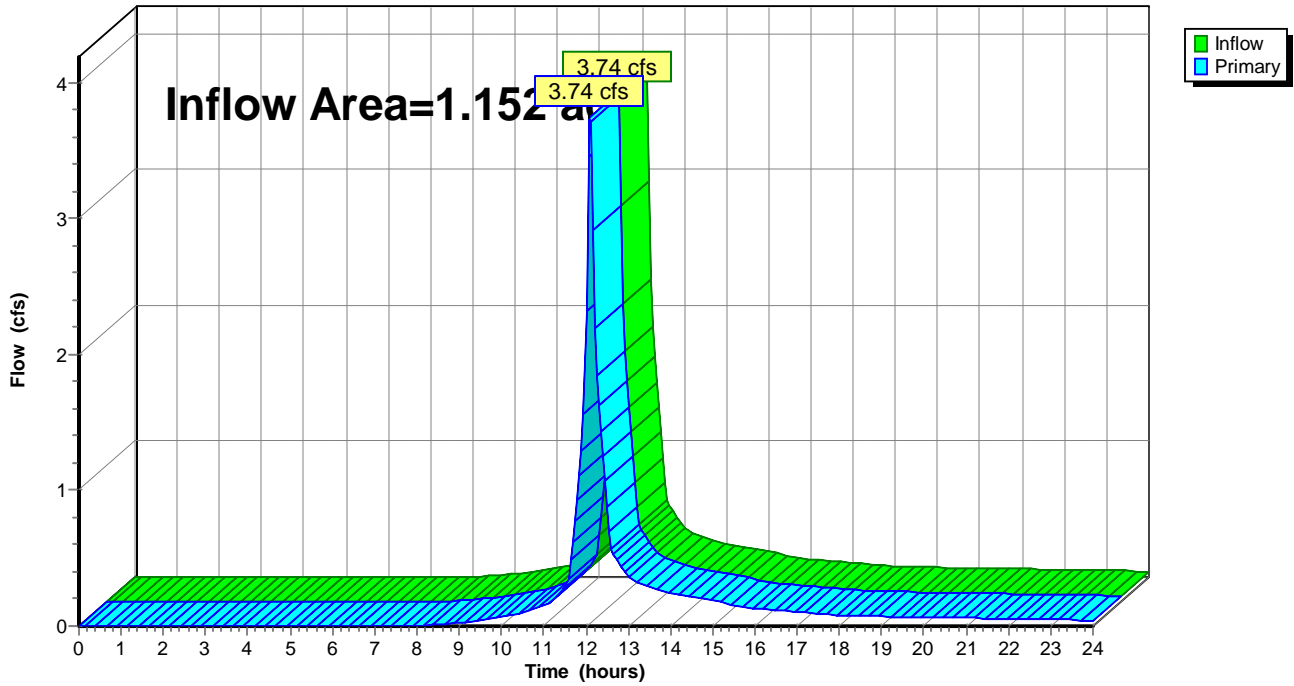

Time span=0.00-24.00 hrs, dt=0.05 hrs, 481 points
 Runoff by SCS TR-20 method, UH=SCS, Weighted-CN
 Reach routing by Stor-Ind+Trans method - Pond routing by Stor-Ind method

Subcatchment PRDA1D: PRDA-1	Runoff Area=360,934 sf 15.66% Impervious Runoff Depth>3.11" Flow Length=850' Tc=42.4 min CN=77 Runoff=14.53 cfs 2.144 af
Subcatchment PRDA1ND: PRDA-1	Runoff Area=430,511 sf 13.86% Impervious Runoff Depth>3.01" Flow Length=1,775' Tc=42.9 min CN=76 Runoff=16.68 cfs 2.479 af
Subcatchment PRDA2AND: PRDA-2A	Runoff Area=103,805 sf 0.00% Impervious Runoff Depth>2.66" Flow Length=400' Tc=24.1 min CN=72 Runoff=4.61 cfs 0.527 af
Subcatchment PRDA2BND: PRDA-2B	Runoff Area=85,134 sf 0.00% Impervious Runoff Depth>2.66" Flow Length=300' Tc=17.4 min CN=72 Runoff=4.32 cfs 0.433 af
Subcatchment PRDA3D: PRDA-3	Runoff Area=407,573 sf 36.10% Impervious Runoff Depth>3.72" Flow Length=1,450' Tc=6.7 min CN=83 Runoff=38.92 cfs 2.899 af
Subcatchment PRDA3ND: PRDA-3	Runoff Area=21,688 sf 76.07% Impervious Runoff Depth>4.67" Flow Length=100' Slope=0.1100 '/' Tc=5.0 min CN=92 Runoff=2.59 cfs 0.194 af
Subcatchment PRDA4ND: PRDA-4	Runoff Area=9,707 sf 20.57% Impervious Runoff Depth>3.32" Flow Length=100' Slope=0.1100 '/' Tc=5.0 min CN=79 Runoff=0.87 cfs 0.062 af
Subcatchment PRDA5ND: PRDA-5	Runoff Area=61,426 sf 22.51% Impervious Runoff Depth>3.32" Flow Length=300' Tc=5.7 min CN=79 Runoff=5.41 cfs 0.390 af
Subcatchment PRDA6ND: PRDA-6	Runoff Area=50,175 sf 19.16% Impervious Runoff Depth>3.32" Flow Length=650' Tc=5.6 min CN=79 Runoff=4.43 cfs 0.319 af
Pond BASIN A: BASIN A	Peak Elev=822.13' Storage=73,424 cf Inflow=38.92 cfs 2.899 af Outflow=2.61 cfs 2.077 af
Pond BASIN B: BASIN B	Peak Elev=823.56' Storage=31,421 cf Inflow=14.53 cfs 2.144 af Outflow=7.67 cfs 1.990 af
Link DP1: DP-1	Inflow=21.65 cfs 4.470 af Primary=21.65 cfs 4.470 af
Link DP2A: DP-2A	Inflow=4.61 cfs 0.527 af Primary=4.61 cfs 0.527 af
Link DP2B: DP-2B	Inflow=4.32 cfs 0.433 af Primary=4.32 cfs 0.433 af
Link DP3: DP-3	Inflow=4.07 cfs 2.271 af Primary=4.07 cfs 2.271 af
Link DP4: DP-4	Inflow=0.87 cfs 0.062 af Primary=0.87 cfs 0.062 af

98132 PR SC

Prepared by CIVIL 1

HydroCAD® 10.00-13 s/n 08208 © 2014 HydroCAD Software Solutions LLC

Type III 24-hr 25-Year Rainfall=5.60"

Printed 2/13/2015

Page 51

Link DP5: DP-5

Inflow=5.41 cfs 0.390 af
Primary=5.41 cfs 0.390 af

Link DP6: DP-6

Inflow=4.43 cfs 0.319 af
Primary=4.43 cfs 0.319 af

Total Runoff Area = 35.146 ac Runoff Volume = 9.448 af Average Runoff Depth = 3.23"
80.06% Pervious = 28.138 ac 19.94% Impervious = 7.008 ac

Summary for Subcatchment PRDA1D: PRDA-1

Runoff = 14.53 cfs @ 12.59 hrs, Volume= 2.144 af, Depth> 3.11"

Runoff by SCS TR-20 method, UH=SCS, Weighted-CN, Time Span= 0.00-24.00 hrs, dt= 0.05 hrs
 Type III 24-hr 25-Year Rainfall=5.60"

Area (sf)	CN	Description
36,718	98	Impervious, HSG C
1,151	98	Roofs, HSG C
18,667	98	Water Surface, HSG C
124,441	74	Pasture/grassland/range, Good, HSG C
* 115,820	75	Gravel, HSG C
64,137	70	Woods, Good, HSG C
360,934	77	Weighted Average
304,398		84.34% Pervious Area
56,536		15.66% Impervious Area

Tc (min)	Length (feet)	Slope (ft/ft)	Velocity (ft/sec)	Capacity (cfs)	Description
37.0	250	0.0320	0.11		Sheet Flow, Woods: Light underbrush n= 0.400 P2= 3.20"
5.4	600	0.0700	1.85		Shallow Concentrated Flow, Short Grass Pasture Kv= 7.0 fps
42.4	850	Total			

Subcatchment PRDA1D: PRDA-1

Hydrograph

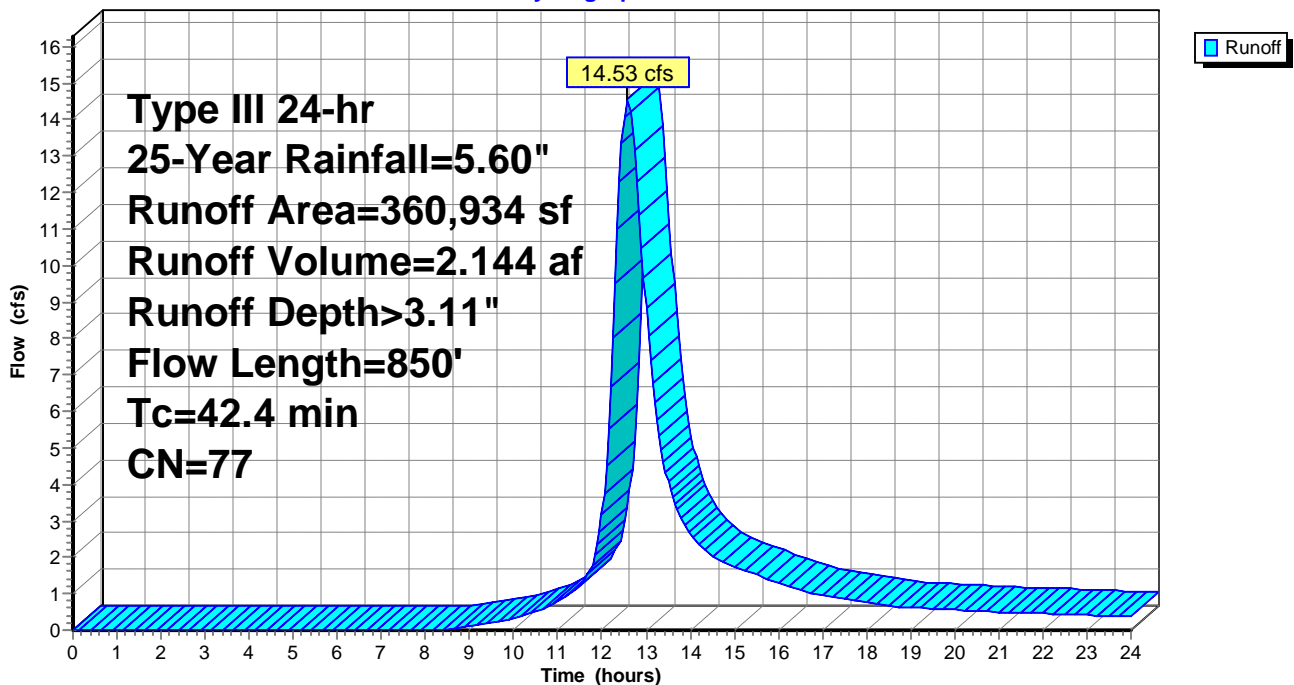

Summary for Subcatchment PRDA1ND: PRDA-1

Runoff = 16.68 cfs @ 12.60 hrs, Volume= 2.479 af, Depth> 3.01"

Runoff by SCS TR-20 method, UH=SCS, Weighted-CN, Time Span= 0.00-24.00 hrs, dt= 0.05 hrs
 Type III 24-hr 25-Year Rainfall=5.60"

Area (sf)	CN	Description
114,584	70	Woods, Good, HSG C
256,245	74	Pasture/grassland/range, Good, HSG C
59,682	98	Impervious, HSG C
430,511	76	Weighted Average
370,829		86.14% Pervious Area
59,682		13.86% Impervious Area

Tc (min)	Length (feet)	Slope (ft/ft)	Velocity (ft/sec)	Capacity (cfs)	Description
37.0	250	0.0320	0.11		Sheet Flow, Woods: Light underbrush n= 0.400 P2= 3.20"
4.9	1,000	0.0440	3.38		Shallow Concentrated Flow, Unpaved Kv= 16.1 fps
1.0	525	0.0570	8.87	53.22	Channel Flow, Area= 6.0 sf Perim= 6.0' r= 1.00' n= 0.040 Earth, cobble bottom, clean sides
42.9	1,775	Total			

Subcatchment PRDA1ND: PRDA-1

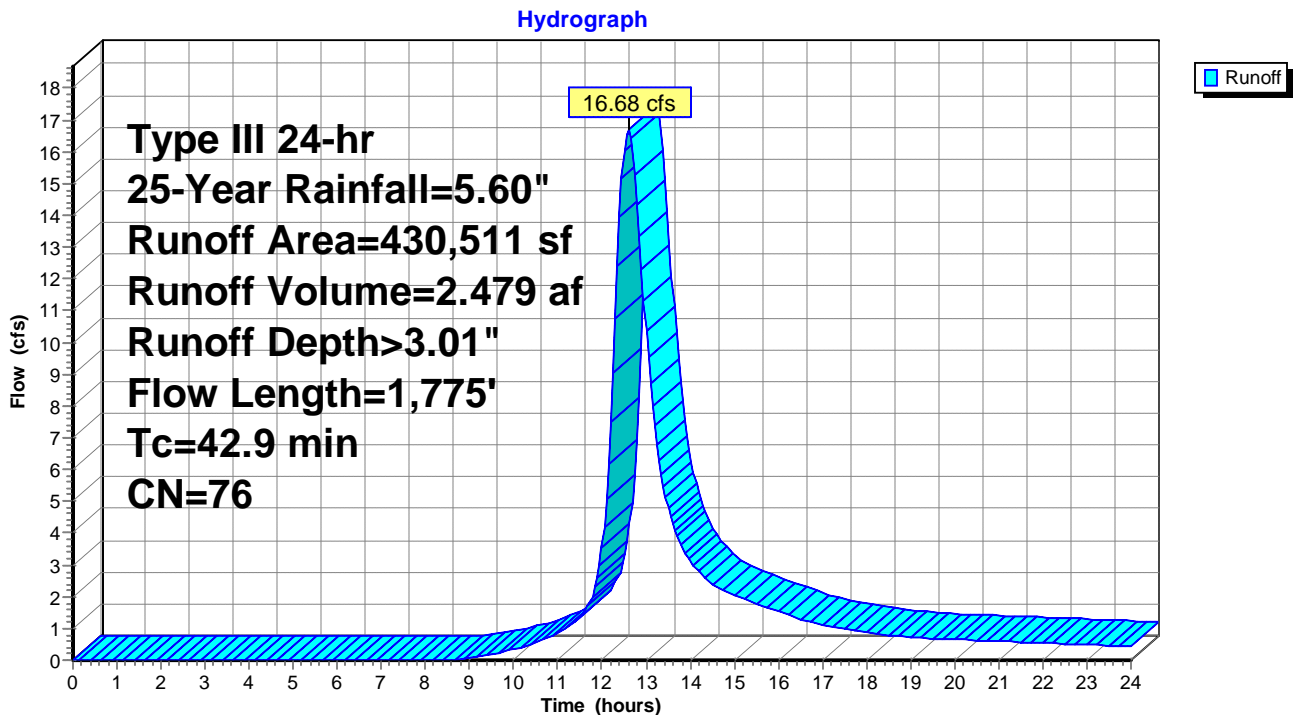

Summary for Subcatchment PRDA2AND: PRDA-2A

Runoff = 4.61 cfs @ 12.34 hrs, Volume= 0.527 af, Depth> 2.66"

Runoff by SCS TR-20 method, UH=SCS, Weighted-CN, Time Span= 0.00-24.00 hrs, dt= 0.05 hrs
 Type III 24-hr 25-Year Rainfall=5.60"

Area (sf)	CN	Description
46,490	70	Woods, Good, HSG C
57,315	74	Pasture/grassland/range, Good, HSG C
103,805	72	Weighted Average
103,805		100.00% Pervious Area

Tc (min)	Length (feet)	Slope (ft/ft)	Velocity (ft/sec)	Capacity (cfs)	Description
23.1	250	0.1040	0.18		Sheet Flow, Woods: Light underbrush n= 0.400 P2= 3.20"
1.0	150	0.2400	2.45		Shallow Concentrated Flow, Woodland Kv= 5.0 fps
24.1	400	Total			

Subcatchment PRDA2AND: PRDA-2A

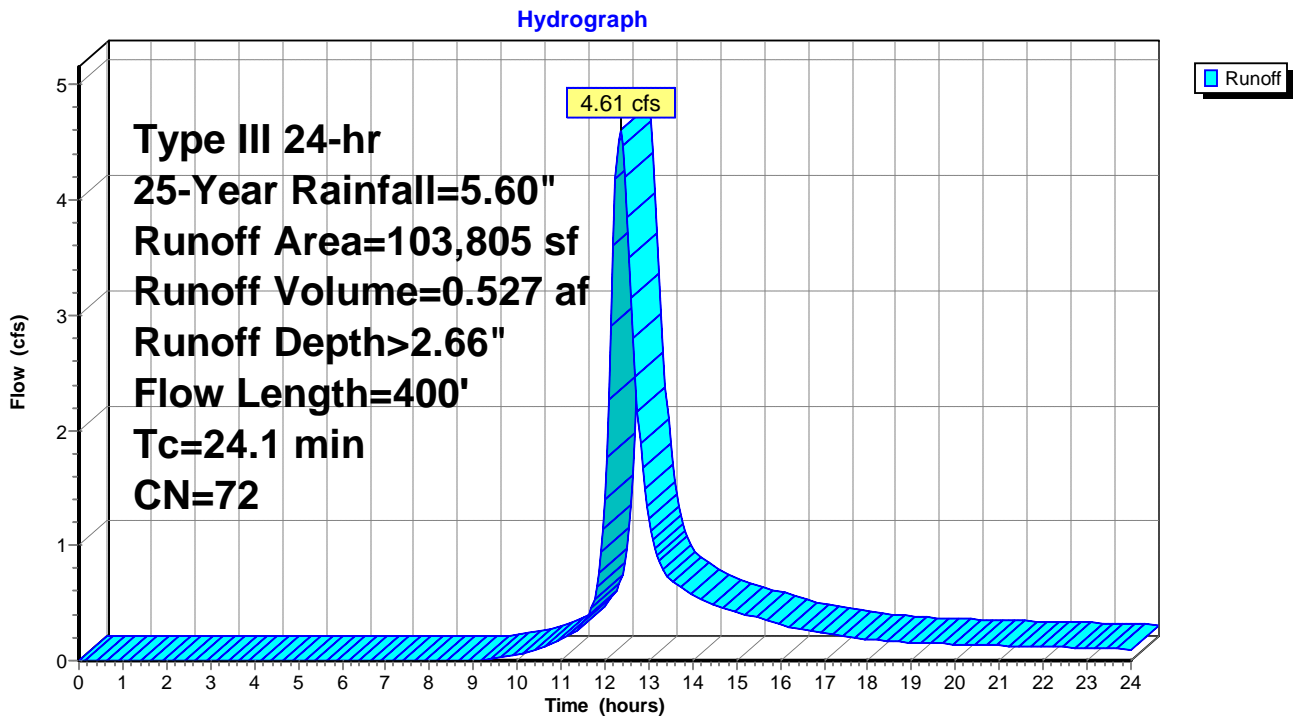

Summary for Subcatchment PRDA2BND: PRDA-2B

Runoff = 4.32 cfs @ 12.25 hrs, Volume= 0.433 af, Depth> 2.66"

Runoff by SCS TR-20 method, UH=SCS, Weighted-CN, Time Span= 0.00-24.00 hrs, dt= 0.05 hrs
 Type III 24-hr 25-Year Rainfall=5.60"

Area (sf)	CN	Description
33,200	70	Woods, Good, HSG C
51,934	74	Pasture/grassland/range, Good, HSG C
85,134	72	Weighted Average
85,134		100.00% Pervious Area

Tc (min)	Length (feet)	Slope (ft/ft)	Velocity (ft/sec)	Capacity (cfs)	Description
16.1	200	0.1650	0.21		Sheet Flow, Woods: Light underbrush n= 0.400 P2= 3.20"
1.3	100	0.0700	1.32		Shallow Concentrated Flow, Woodland Kv= 5.0 fps
17.4	300	Total			

Subcatchment PRDA2BND: PRDA-2B

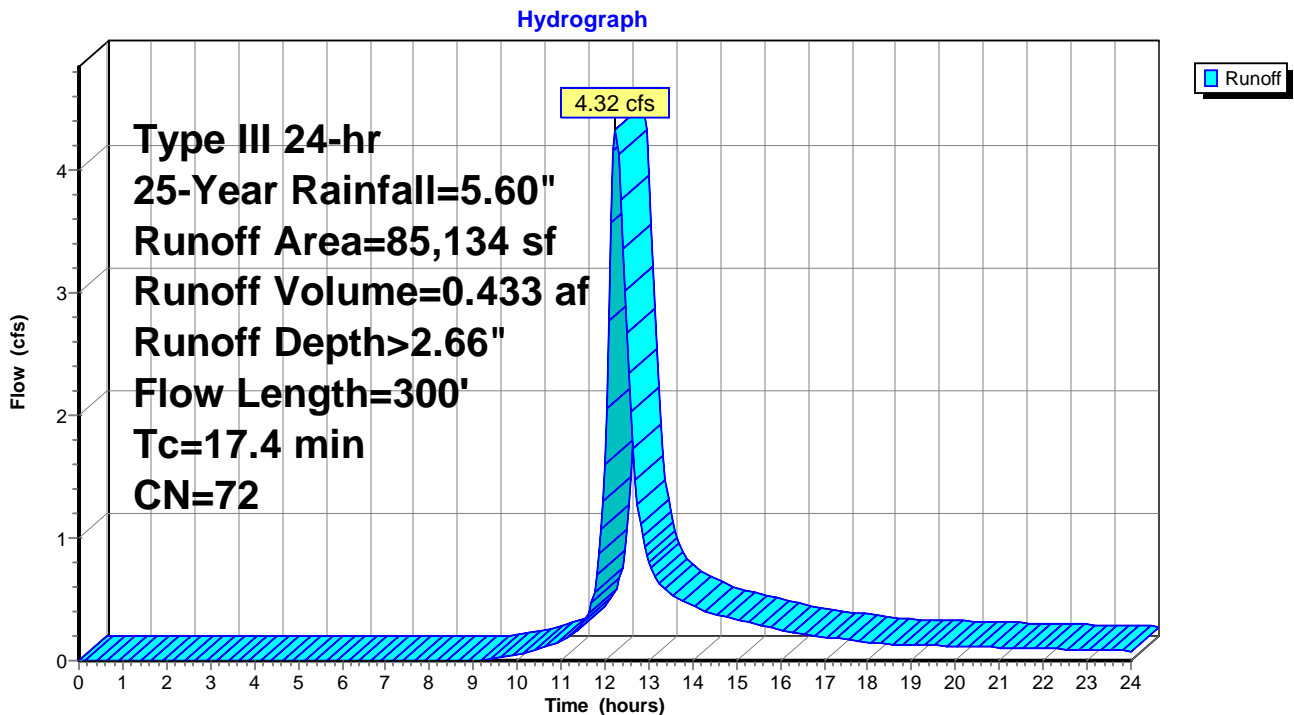

Summary for Subcatchment PRDA3D: PRDA-3

Runoff = 38.92 cfs @ 12.10 hrs, Volume= 2.899 af, Depth> 3.72"

Runoff by SCS TR-20 method, UH=SCS, Weighted-CN, Time Span= 0.00-24.00 hrs, dt= 0.05 hrs
 Type III 24-hr 25-Year Rainfall=5.60"

Area (sf)	CN	Description
69,087	98	Impervious, HSG C
36,569	98	Roofs, HSG C
41,458	98	Water Surface, HSG C
* 260,459	75	Gravel, HSG C
407,573	83	Weighted Average
260,459		63.90% Pervious Area
147,114		36.10% Impervious Area

Tc (min)	Length (feet)	Slope (ft/ft)	Velocity (ft/sec)	Capacity (cfs)	Description
3.3	250	0.0100	1.25		Sheet Flow, Smooth surfaces n= 0.011 P2= 3.20"
3.4	1,200	0.0075	5.93	7.27	Pipe Channel, 15.0" Round Area= 1.2 sf Perim= 3.9' r= 0.31' n= 0.010 PVC, smooth interior
6.7	1,450	Total			

Subcatchment PRDA3D: PRDA-3

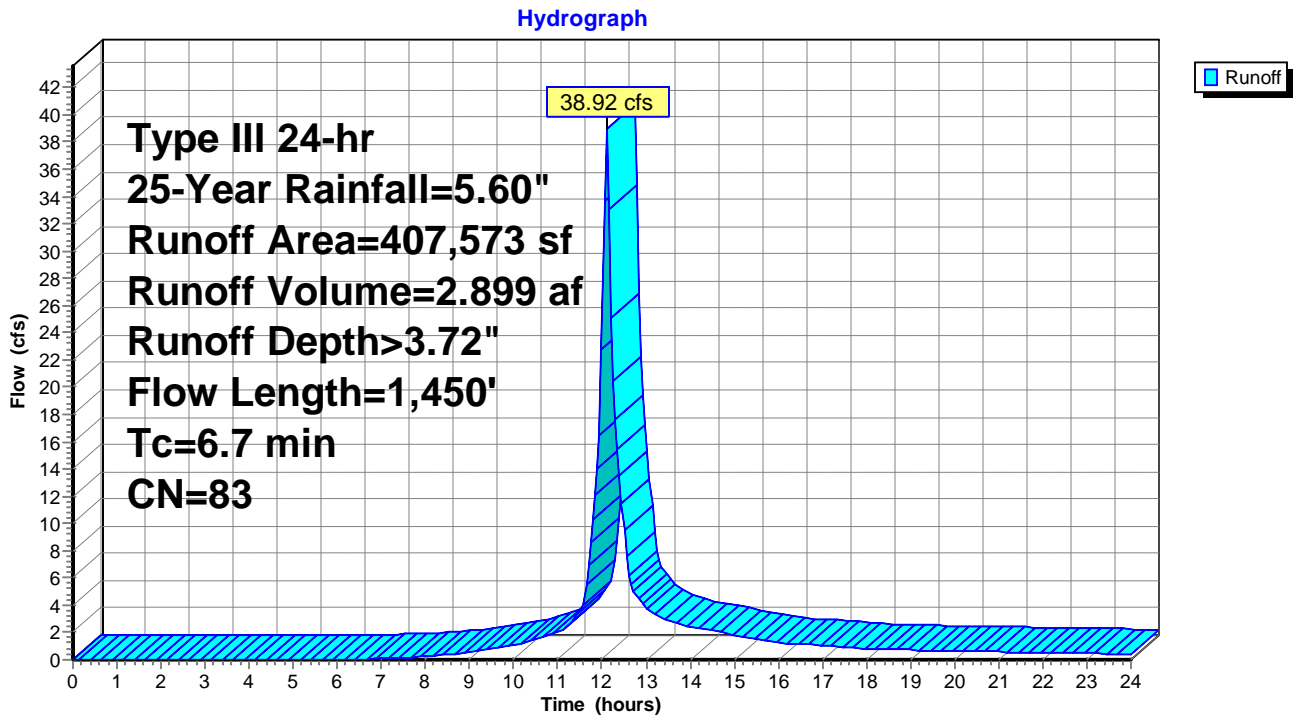

Summary for Subcatchment PRDA3ND: PRDA-3

Runoff = 2.59 cfs @ 12.07 hrs, Volume= 0.194 af, Depth> 4.67"

Runoff by SCS TR-20 method, UH=SCS, Weighted-CN, Time Span= 0.00-24.00 hrs, dt= 0.05 hrs
 Type III 24-hr 25-Year Rainfall=5.60"

Area (sf)	CN	Description
5,191	74	Pasture/grassland/range, Good, HSG C
16,497	98	Impervious, HSG C
21,688	92	Weighted Average
5,191		23.93% Pervious Area
16,497		76.07% Impervious Area

Tc (min)	Length (feet)	Slope (ft/ft)	Velocity (ft/sec)	Capacity (cfs)	Description
5.0	100	0.1100	0.34		Sheet Flow, Grass: Short n= 0.150 P2= 3.20"

Subcatchment PRDA3ND: PRDA-3

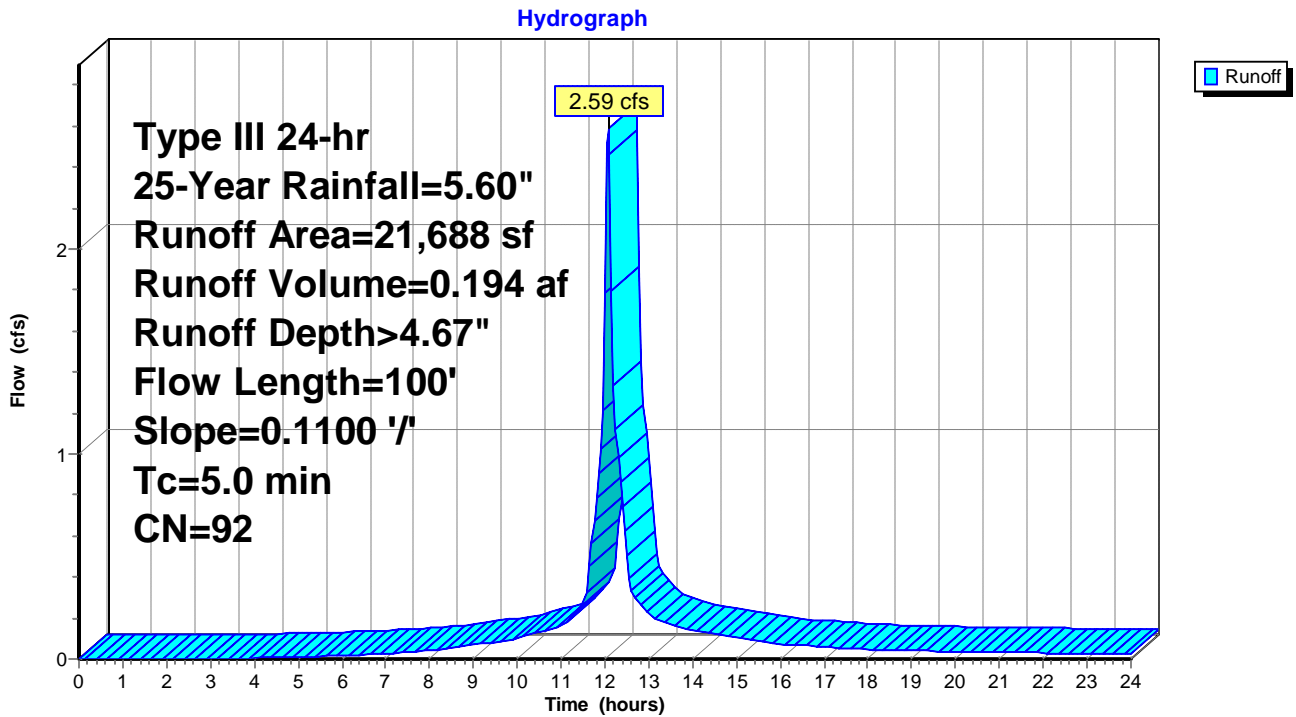

Summary for Subcatchment PRDA4ND: PRDA-4

Runoff = 0.87 cfs @ 12.08 hrs, Volume= 0.062 af, Depth> 3.32"

Runoff by SCS TR-20 method, UH=SCS, Weighted-CN, Time Span= 0.00-24.00 hrs, dt= 0.05 hrs
 Type III 24-hr 25-Year Rainfall=5.60"

Area (sf)	CN	Description
7,710	74	Pasture/grassland/range, Good, HSG C
* 1,997	98	Impervious
9,707	79	Weighted Average
7,710		79.43% Pervious Area
1,997		20.57% Impervious Area

Tc (min)	Length (feet)	Slope (ft/ft)	Velocity (ft/sec)	Capacity (cfs)	Description
5.0	100	0.1100	0.34		Sheet Flow, Grass: Short n= 0.150 P2= 3.20"

Subcatchment PRDA4ND: PRDA-4

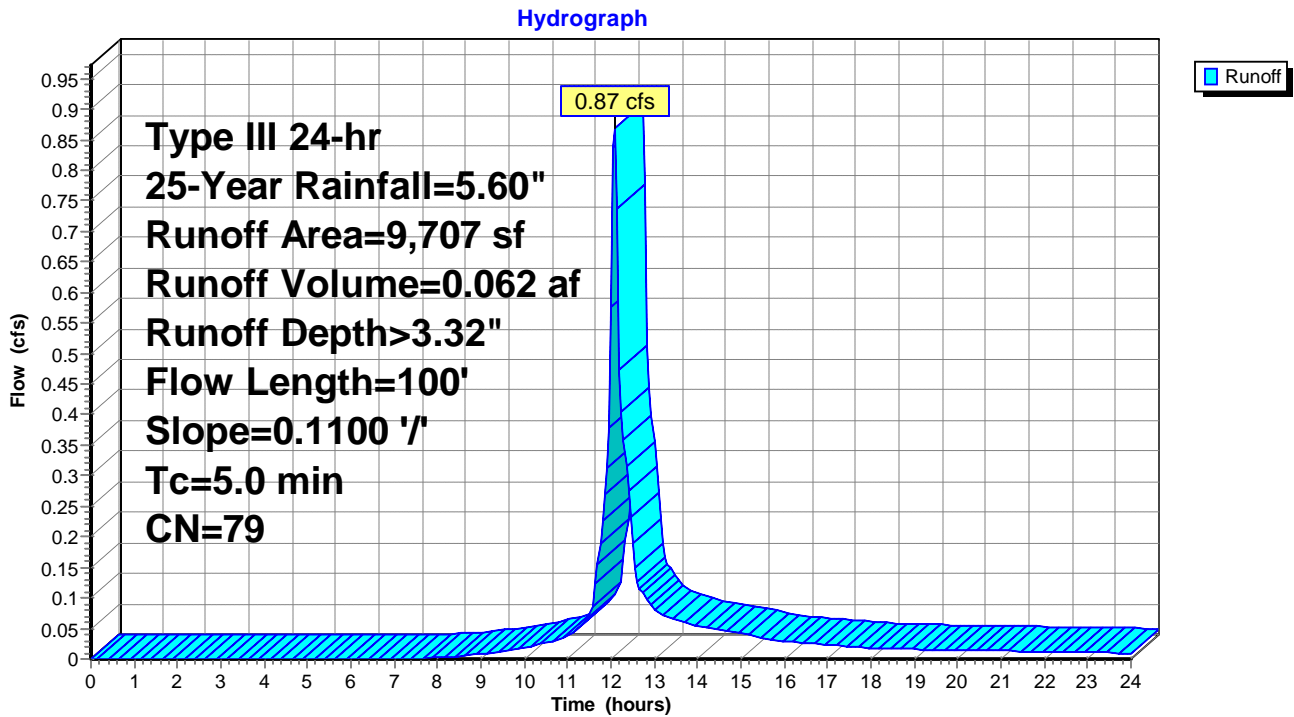

Summary for Subcatchment PRDA5ND: PRDA-5

Runoff = 5.41 cfs @ 12.09 hrs, Volume= 0.390 af, Depth> 3.32"

Runoff by SCS TR-20 method, UH=SCS, Weighted-CN, Time Span= 0.00-24.00 hrs, dt= 0.05 hrs
 Type III 24-hr 25-Year Rainfall=5.60"

Area (sf)	CN	Description
13,824	98	Impervious, HSG C
47,602	74	Pasture/grassland/range, Good, HSG C
61,426	79	Weighted Average
47,602		77.49% Pervious Area
13,824		22.51% Impervious Area

Tc (min)	Length (feet)	Slope (ft/ft)	Velocity (ft/sec)	Capacity (cfs)	Description
5.5	200	0.3333	0.60		Sheet Flow, Grass: Short n= 0.150 P2= 3.20"
0.2	100	0.0100	6.84	8.40	Pipe Channel, 15.0" Round Area= 1.2 sf Perim= 3.9' r= 0.31' n= 0.010 PVC, smooth interior
5.7	300	Total			

Subcatchment PRDA5ND: PRDA-5

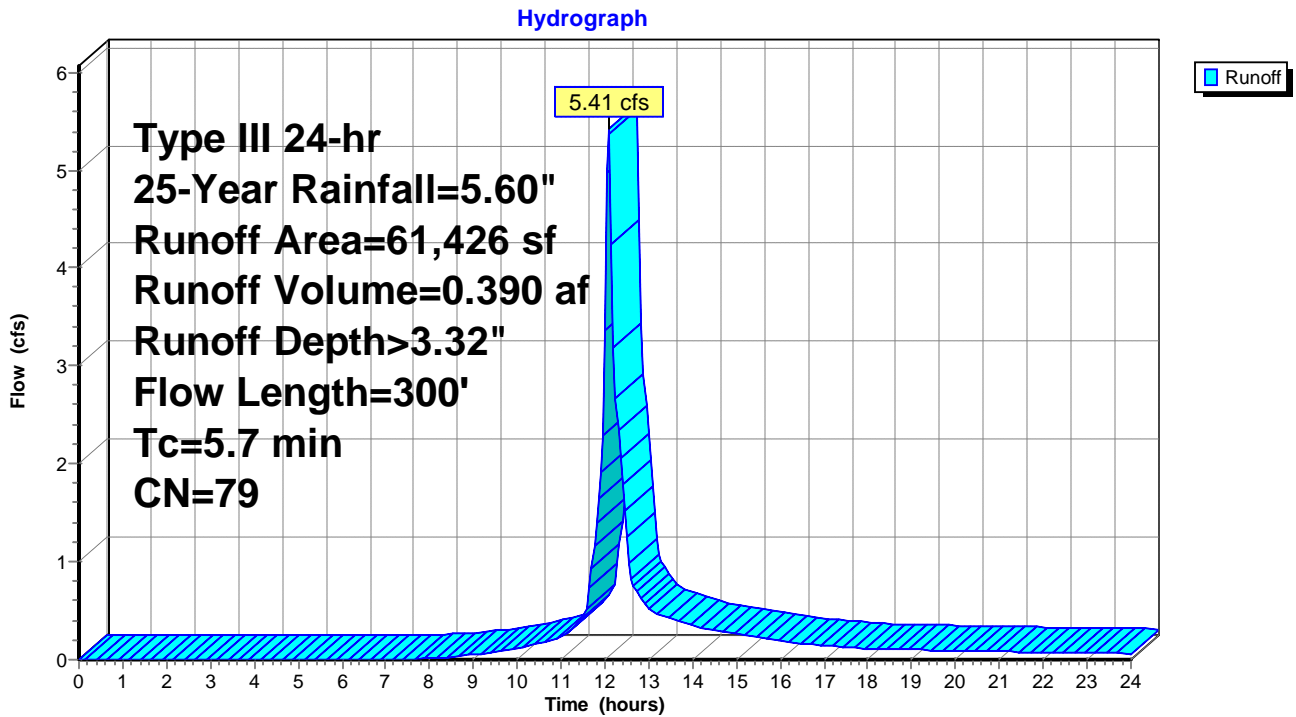

Summary for Subcatchment PRDA6ND: PRDA-6

Runoff = 4.43 cfs @ 12.09 hrs, Volume= 0.319 af, Depth> 3.32"

Runoff by SCS TR-20 method, UH=SCS, Weighted-CN, Time Span= 0.00-24.00 hrs, dt= 0.05 hrs
 Type III 24-hr 25-Year Rainfall=5.60"

Area (sf)	CN	Description
40,563	74	Pasture/grassland/range, Good, HSG C
9,612	98	Impervious, HSG C
50,175	79	Weighted Average
40,563		80.84% Pervious Area
9,612		19.16% Impervious Area

Tc (min)	Length (feet)	Slope (ft/ft)	Velocity (ft/sec)	Capacity (cfs)	Description
4.4	150	0.3333	0.57		Sheet Flow, Grass: Short n= 0.150 P2= 3.20"
1.2	500	0.2050	6.79		Shallow Concentrated Flow, Grassed Waterway Kv= 15.0 fps
5.6	650	Total			

Subcatchment PRDA6ND: PRDA-6

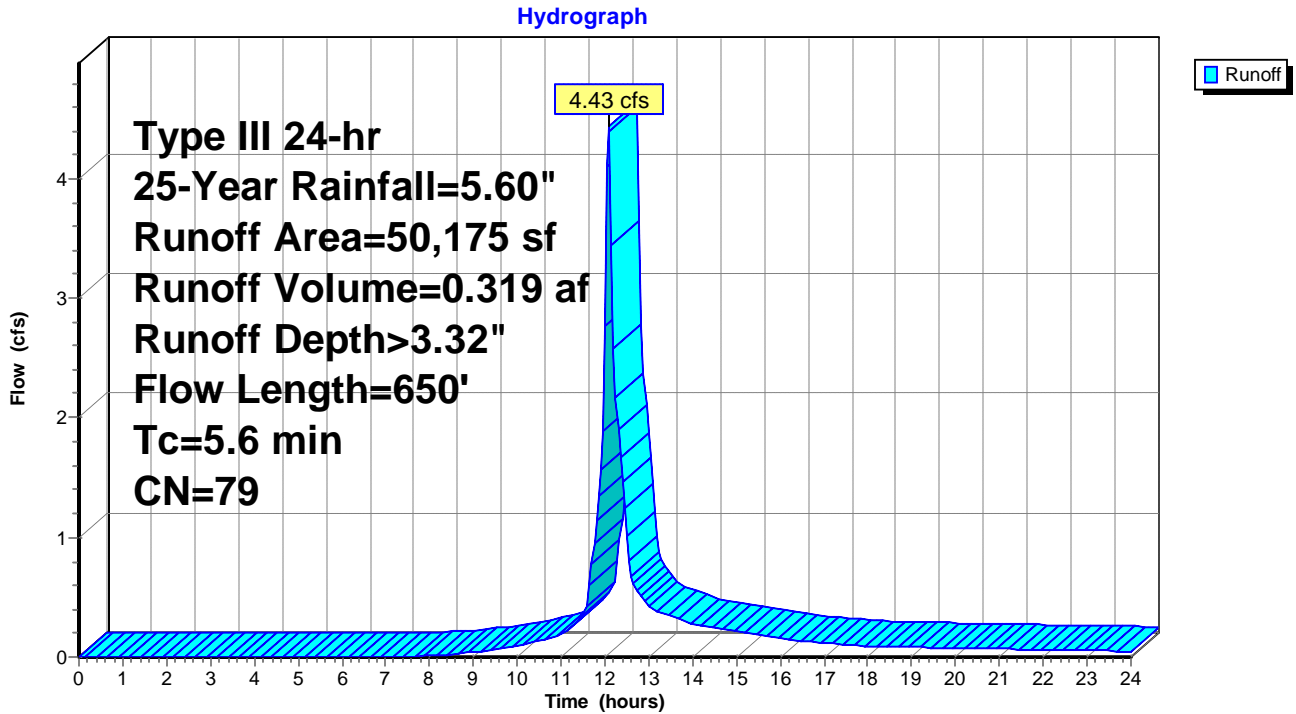

Summary for Pond BASIN A: BASIN A

Inflow Area = 9.357 ac, 36.10% Impervious, Inflow Depth > 3.72" for 25-Year event
 Inflow = 38.92 cfs @ 12.10 hrs, Volume= 2.899 af
 Outflow = 2.61 cfs @ 13.82 hrs, Volume= 2.077 af, Atten= 93%, Lag= 103.4 min
 Primary = 2.61 cfs @ 13.82 hrs, Volume= 2.077 af

Routing by Stor-Ind method, Time Span= 0.00-24.00 hrs, dt= 0.05 hrs
 Peak Elev= 822.13' @ 13.82 hrs Surf.Area= 38,306 sf Storage= 73,424 cf

Plug-Flow detention time= 321.4 min calculated for 2.077 af (72% of inflow)
 Center-of-Mass det. time= 230.6 min (1,039.6 - 809.0)

Volume	Invert	Avail.Storage	Storage Description
#1	820.00'	151,470 cf	Basin A (Irregular) Listed below (Recalc)

Elevation (feet)	Surf.Area (sq-ft)	Perim. (feet)	Inc.Store (cubic-feet)	Cum.Store (cubic-feet)	Wet.Area (sq-ft)
820.00	30,856	1,150.0	0	0	30,856
822.00	37,867	1,187.0	68,603	68,603	38,123
824.00	45,105	1,225.0	82,867	151,470	45,805

Device	Routing	Invert	Outlet Devices
#1	Primary	820.00'	15.0" Round Culvert L= 250.0' Ke= 0.500 Inlet / Outlet Invert= 820.00' / 786.00' S= 0.1360 '/' Cc= 0.900 n= 0.010 PVC, smooth interior, Flow Area= 1.23 sf
#2	Device 1	820.00'	8.0" Vert. Orifice/Grate C= 0.600
#3	Device 1	822.00'	15.0" W x 12.0" H Vert. Orifice/Grate X 2.00 C= 0.600

Primary OutFlow Max=2.61 cfs @ 13.82 hrs HW=822.13' (Free Discharge)

- 1=Culvert (Passes 2.61 cfs of 7.24 cfs potential flow)
- 2=Orifice/Grate (Orifice Controls 2.25 cfs @ 6.45 fps)
- 3=Orifice/Grate (Orifice Controls 0.36 cfs @ 1.14 fps)

Pond BASIN A: BASIN A

Hydrograph

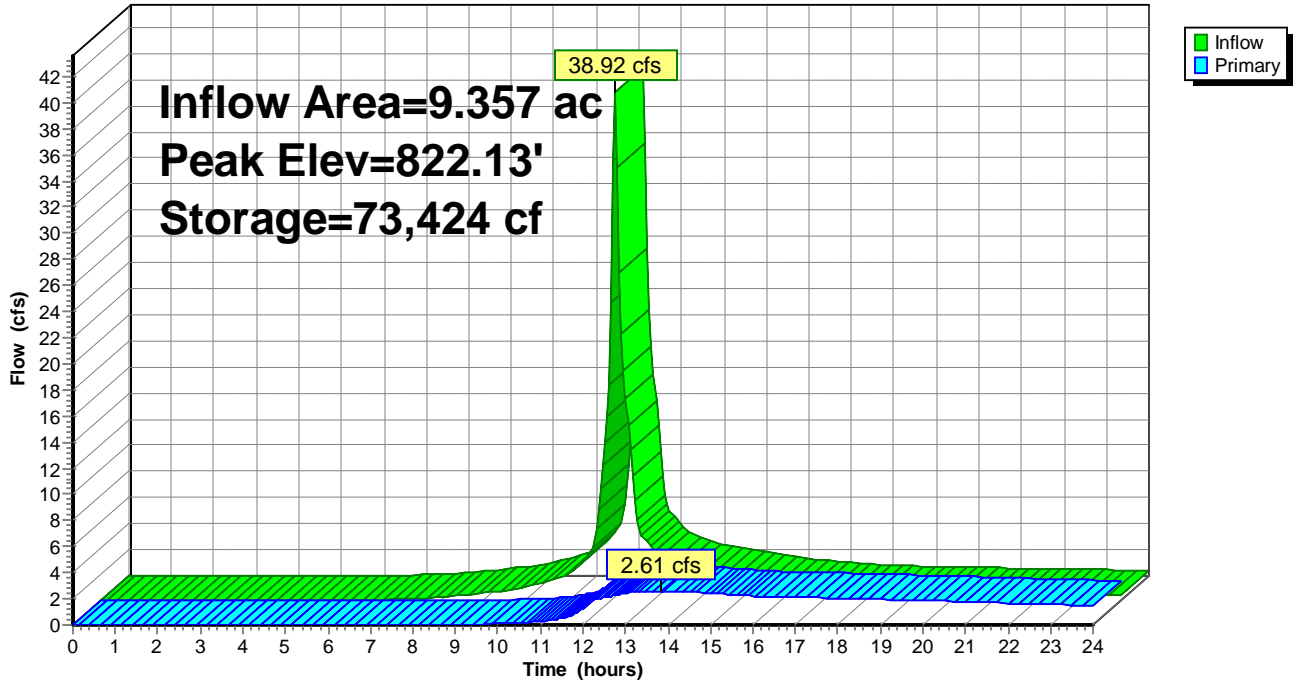

Summary for Pond BASIN B: BASIN B

Inflow Area = 8.286 ac, 15.66% Impervious, Inflow Depth > 3.11" for 25-Year event
 Inflow = 14.53 cfs @ 12.59 hrs, Volume= 2.144 af
 Outflow = 7.67 cfs @ 13.08 hrs, Volume= 1.990 af, Atten= 47%, Lag= 29.6 min
 Primary = 7.67 cfs @ 13.08 hrs, Volume= 1.990 af

Routing by Stor-Ind method, Time Span= 0.00-24.00 hrs, dt= 0.05 hrs
 Peak Elev= 823.56' @ 13.08 hrs Surf.Area= 15,198 sf Storage= 31,421 cf

Plug-Flow detention time= 112.0 min calculated for 1.990 af (93% of inflow)
 Center-of-Mass det. time= 76.6 min (929.7 - 853.1)

Volume	Invert	Avail.Storage	Storage Description		
#1	821.00'	122,878 cf	Basin B (Irregular) Listed below (Recalc)		
Elevation (feet)	Surf.Area (sq-ft)	Perim. (feet)	Inc.Store (cubic-feet)	Cum.Store (cubic-feet)	Wet.Area (sq-ft)
821.00	9,468	729.0	0	0	9,468
822.00	11,682	748.0	10,556	10,556	11,820
824.00	16,283	786.0	27,838	38,394	16,706
826.00	21,113	824.1	37,292	75,685	21,846
828.00	26,170	850.0	47,193	122,878	25,681

Device	Routing	Invert	Outlet Devices	
#1	Primary	821.00'	18.0" Round Culvert L= 100.0' Ke= 0.500 Inlet / Outlet Invert= 821.00' / 797.00' S= 0.2400 '/' Cc= 0.900 n= 0.010 PVC, smooth interior, Flow Area= 1.77 sf	
#2	Device 1	821.00'	6.0" Vert. Orifice/Grate C= 0.600	
#3	Device 1	822.00'	12.0" W x 30.0" H Vert. Orifice/Grate C= 0.600	
#4	Primary	825.00'	24.0" Vert. Orifice/Grate C= 0.600	

Primary OutFlow Max=7.67 cfs @ 13.08 hrs HW=823.56' (Free Discharge)

- 1=Culvert (Passes 7.67 cfs of 11.43 cfs potential flow)
- 2=Orifice/Grate (Orifice Controls 1.44 cfs @ 7.31 fps)
- 3=Orifice/Grate (Orifice Controls 6.23 cfs @ 4.00 fps)
- 4=Orifice/Grate (Controls 0.00 cfs)

Pond BASIN B: BASIN B

Hydrograph

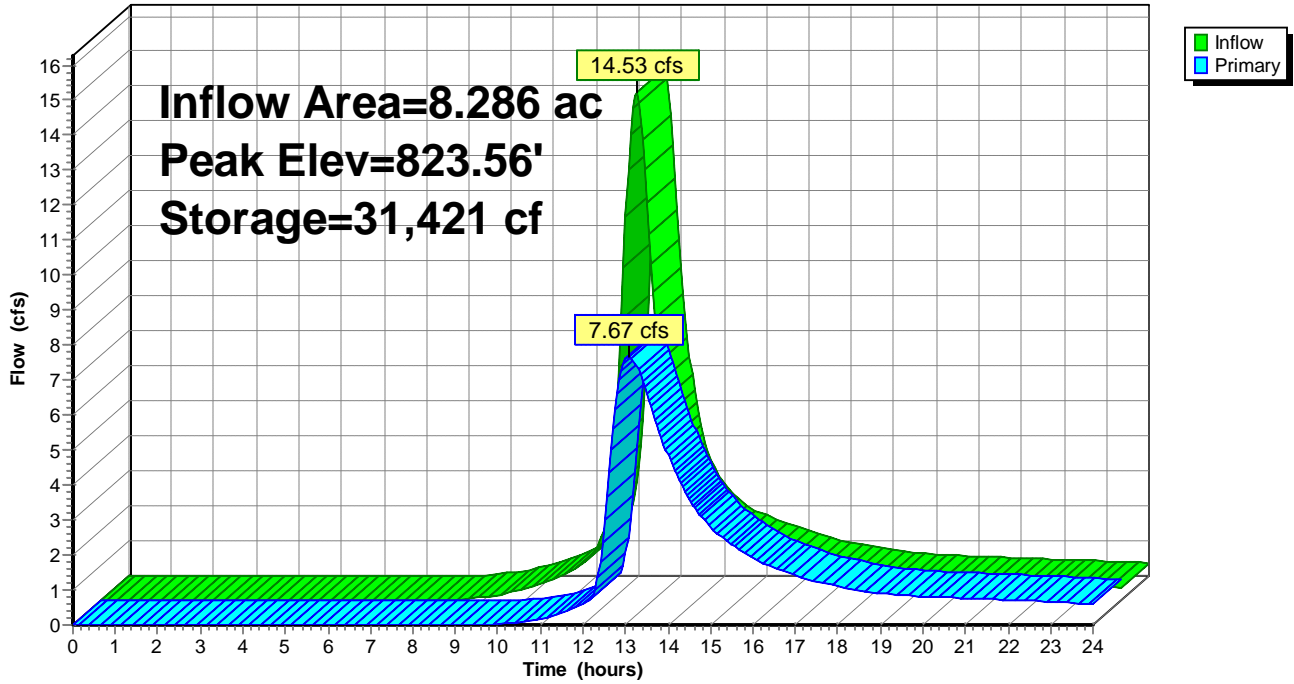

Summary for Link DP1: DP-1

Inflow Area = 18.169 ac, 14.68% Impervious, Inflow Depth > 2.95" for 25-Year event
Inflow = 21.65 cfs @ 12.69 hrs, Volume= 4.470 af
Primary = 21.65 cfs @ 12.69 hrs, Volume= 4.470 af, Atten= 0%, Lag= 0.0 min

Primary outflow = Inflow, Time Span= 0.00-24.00 hrs, dt= 0.05 hrs

Link DP1: DP-1

Hydrograph

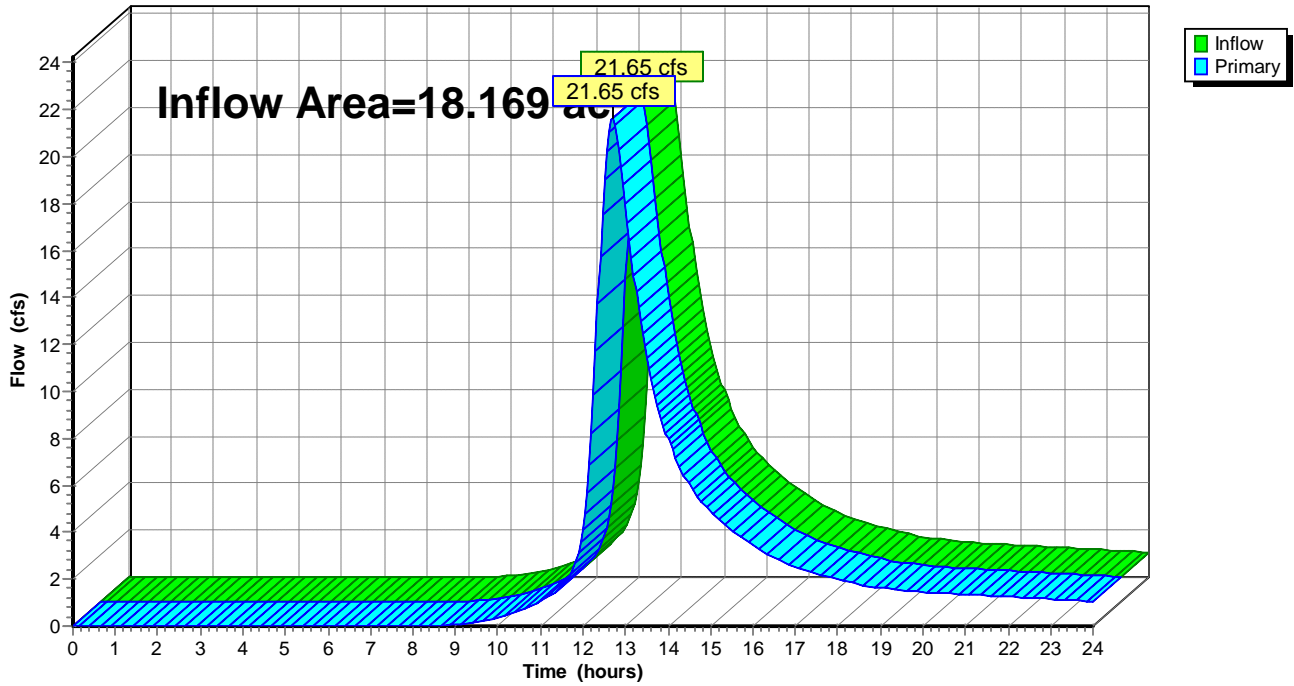

Summary for Link DP2A: DP-2A

Inflow Area = 2.383 ac, 0.00% Impervious, Inflow Depth > 2.66" for 25-Year event
Inflow = 4.61 cfs @ 12.34 hrs, Volume= 0.527 af
Primary = 4.61 cfs @ 12.34 hrs, Volume= 0.527 af, Atten= 0%, Lag= 0.0 min

Primary outflow = Inflow, Time Span= 0.00-24.00 hrs, dt= 0.05 hrs

Link DP2A: DP-2A

Hydrograph

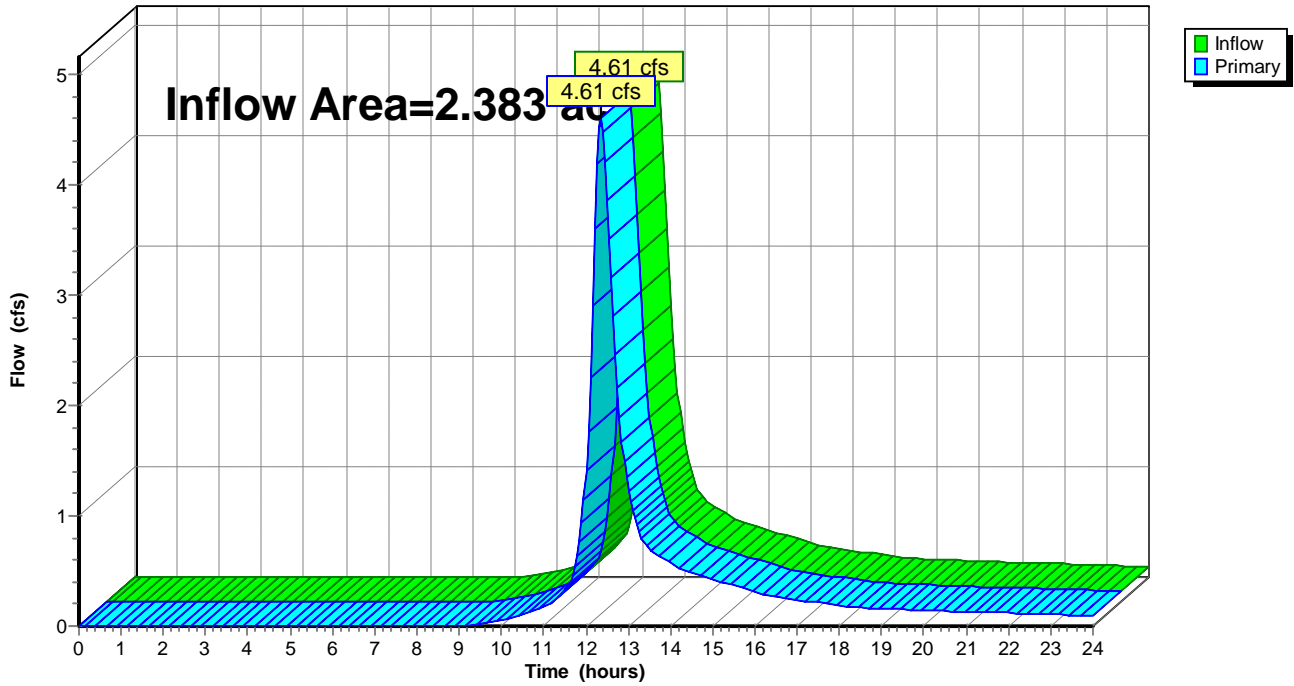

Summary for Link DP2B: DP-2B

Inflow Area = 1.954 ac, 0.00% Impervious, Inflow Depth > 2.66" for 25-Year event
Inflow = 4.32 cfs @ 12.25 hrs, Volume= 0.433 af
Primary = 4.32 cfs @ 12.25 hrs, Volume= 0.433 af, Atten= 0%, Lag= 0.0 min

Primary outflow = Inflow, Time Span= 0.00-24.00 hrs, dt= 0.05 hrs

Link DP2B: DP-2B

Hydrograph

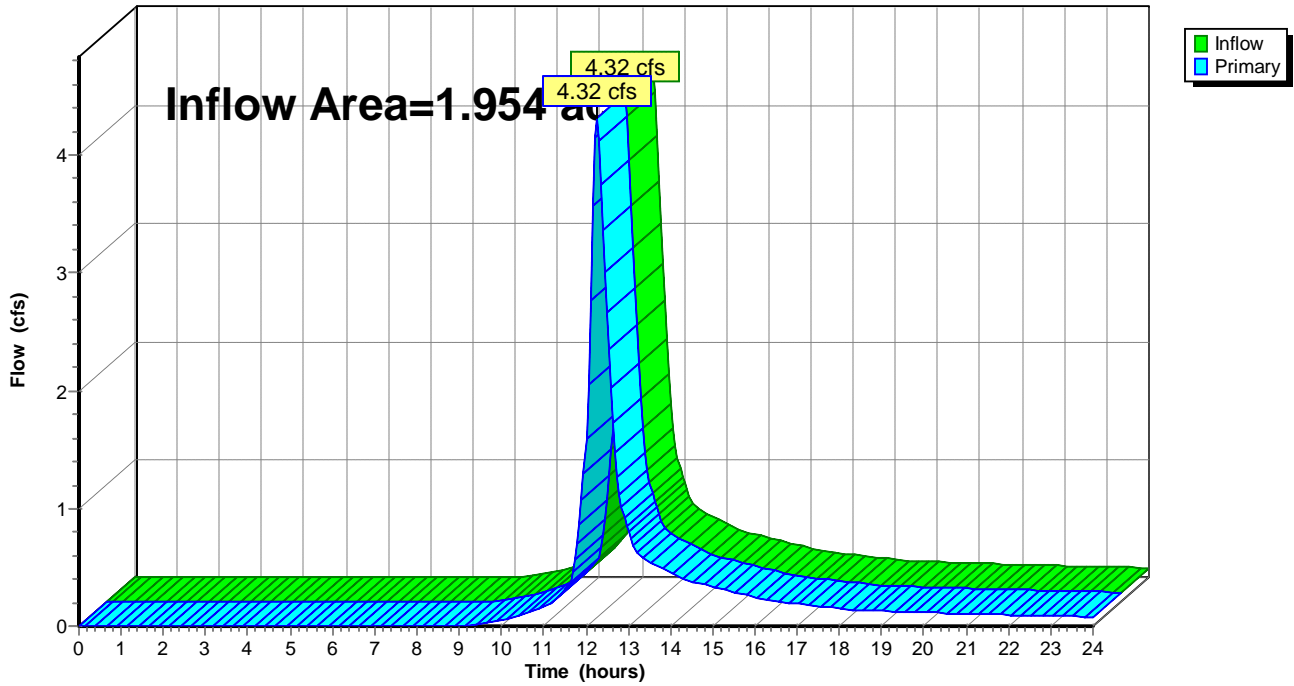

Summary for Link DP3: DP-3

Inflow Area = 9.854 ac, 38.11% Impervious, Inflow Depth > 2.77" for 25-Year event
Inflow = 4.07 cfs @ 12.08 hrs, Volume= 2.271 af
Primary = 4.07 cfs @ 12.08 hrs, Volume= 2.271 af, Atten= 0%, Lag= 0.0 min

Primary outflow = Inflow, Time Span= 0.00-24.00 hrs, dt= 0.05 hrs

Link DP3: DP-3

Hydrograph

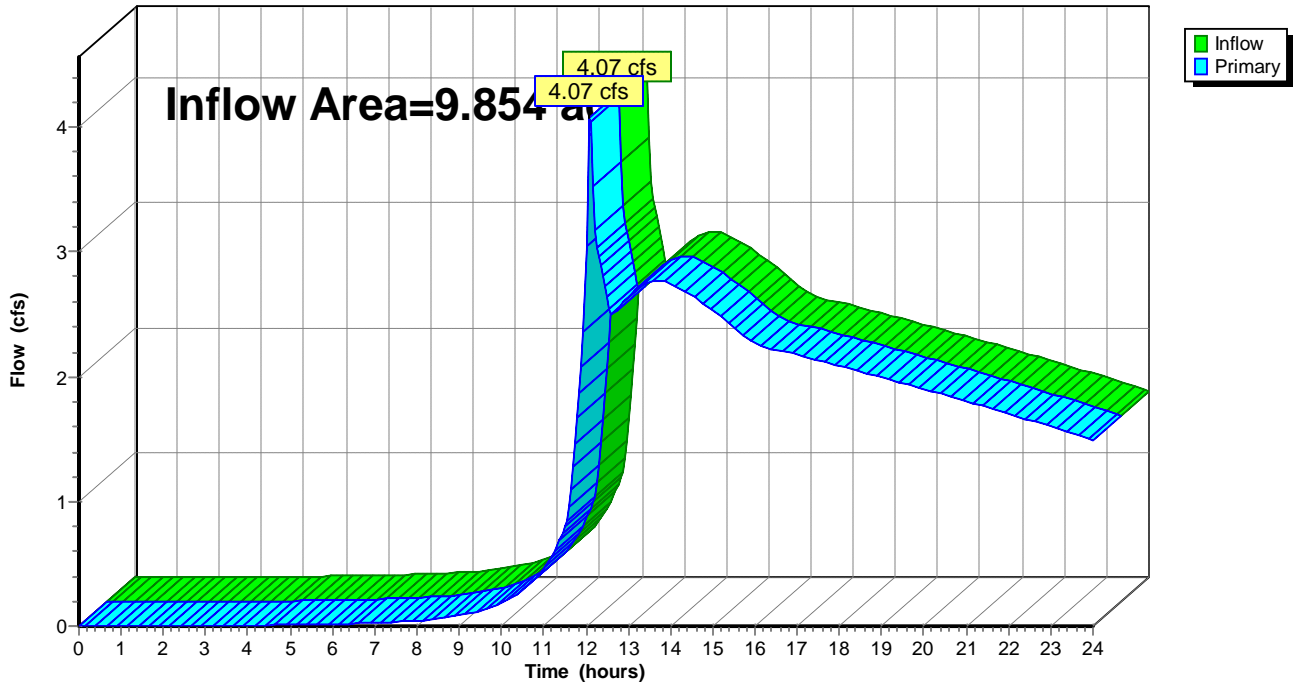

Summary for Link DP4: DP-4

Inflow Area = 0.223 ac, 20.57% Impervious, Inflow Depth > 3.32" for 25-Year event
Inflow = 0.87 cfs @ 12.08 hrs, Volume= 0.062 af
Primary = 0.87 cfs @ 12.08 hrs, Volume= 0.062 af, Atten= 0%, Lag= 0.0 min

Primary outflow = Inflow, Time Span= 0.00-24.00 hrs, dt= 0.05 hrs

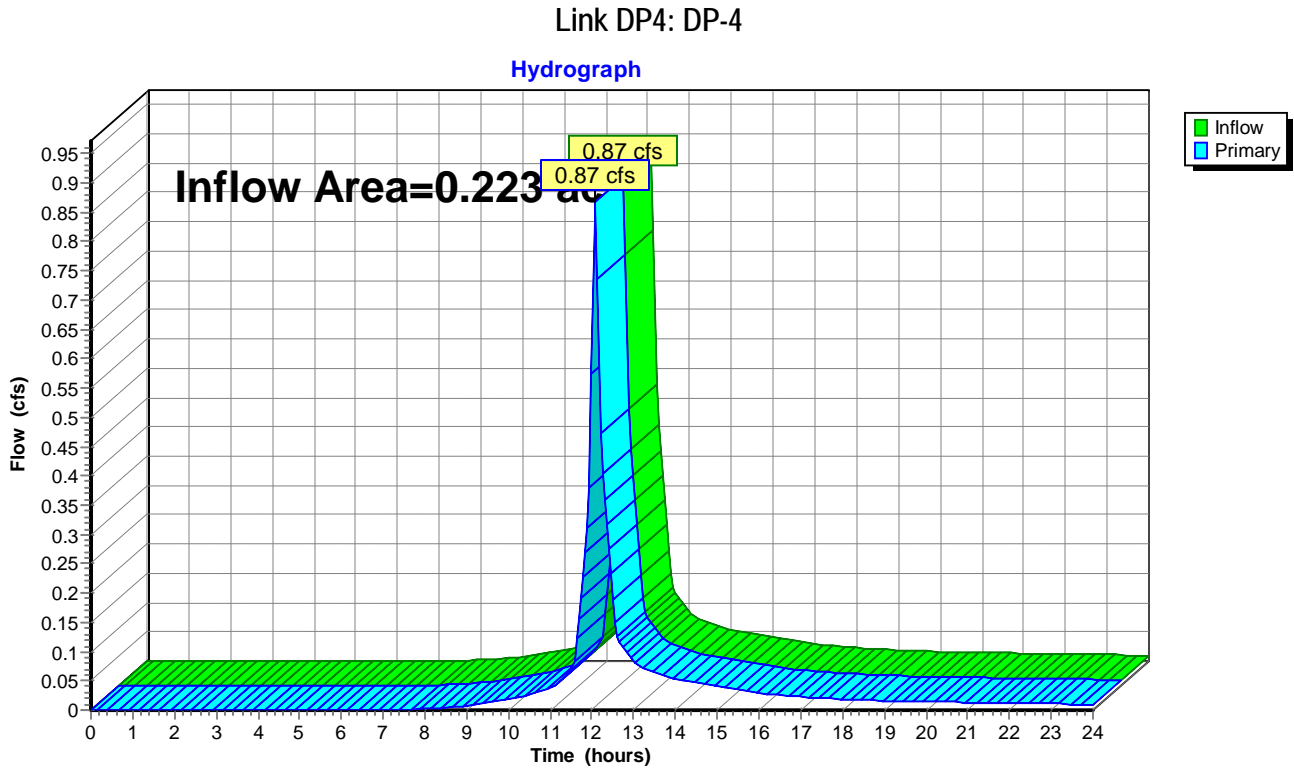

Summary for Link DP5: DP-5

Inflow Area = 1.410 ac, 22.51% Impervious, Inflow Depth > 3.32" for 25-Year event
Inflow = 5.41 cfs @ 12.09 hrs, Volume= 0.390 af
Primary = 5.41 cfs @ 12.09 hrs, Volume= 0.390 af, Atten= 0%, Lag= 0.0 min

Primary outflow = Inflow, Time Span= 0.00-24.00 hrs, dt= 0.05 hrs

Link DP5: DP-5

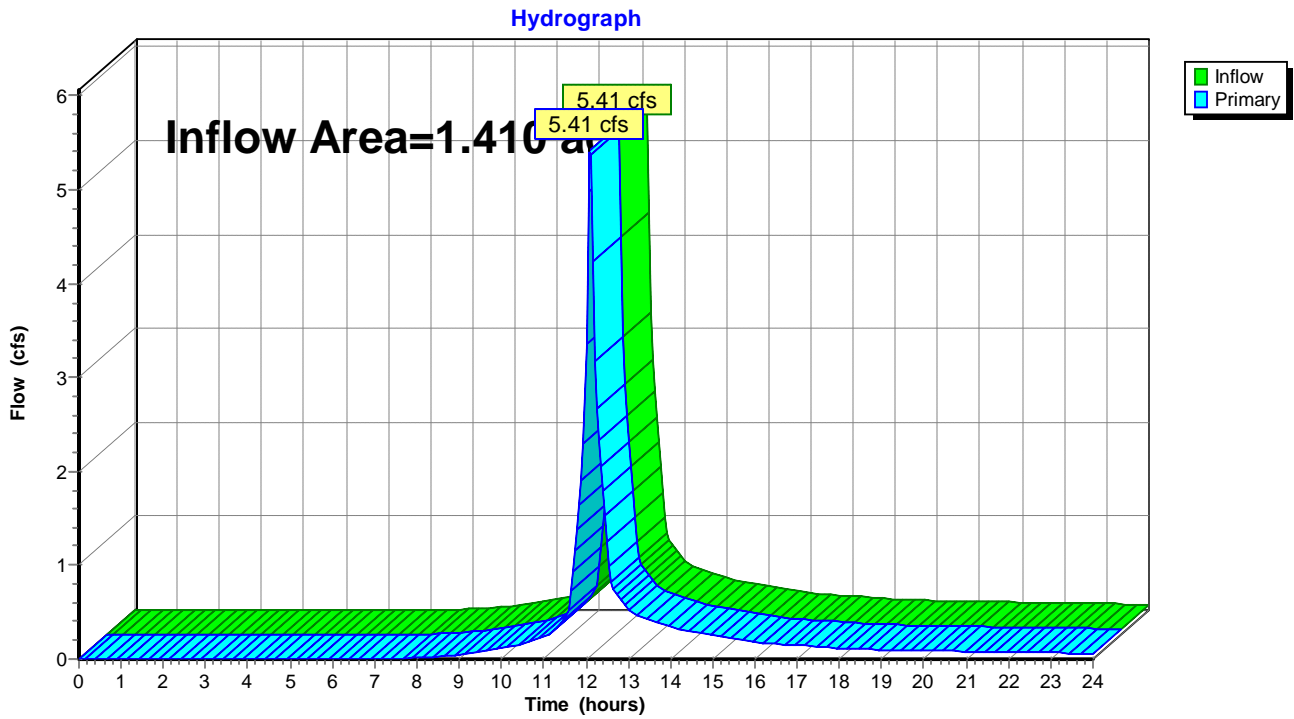

Summary for Link DP6: DP-6

Inflow Area = 1.152 ac, 19.16% Impervious, Inflow Depth > 3.32" for 25-Year event
Inflow = 4.43 cfs @ 12.09 hrs, Volume= 0.319 af
Primary = 4.43 cfs @ 12.09 hrs, Volume= 0.319 af, Atten= 0%, Lag= 0.0 min

Primary outflow = Inflow, Time Span= 0.00-24.00 hrs, dt= 0.05 hrs

Link DP6: DP-6

Hydrograph

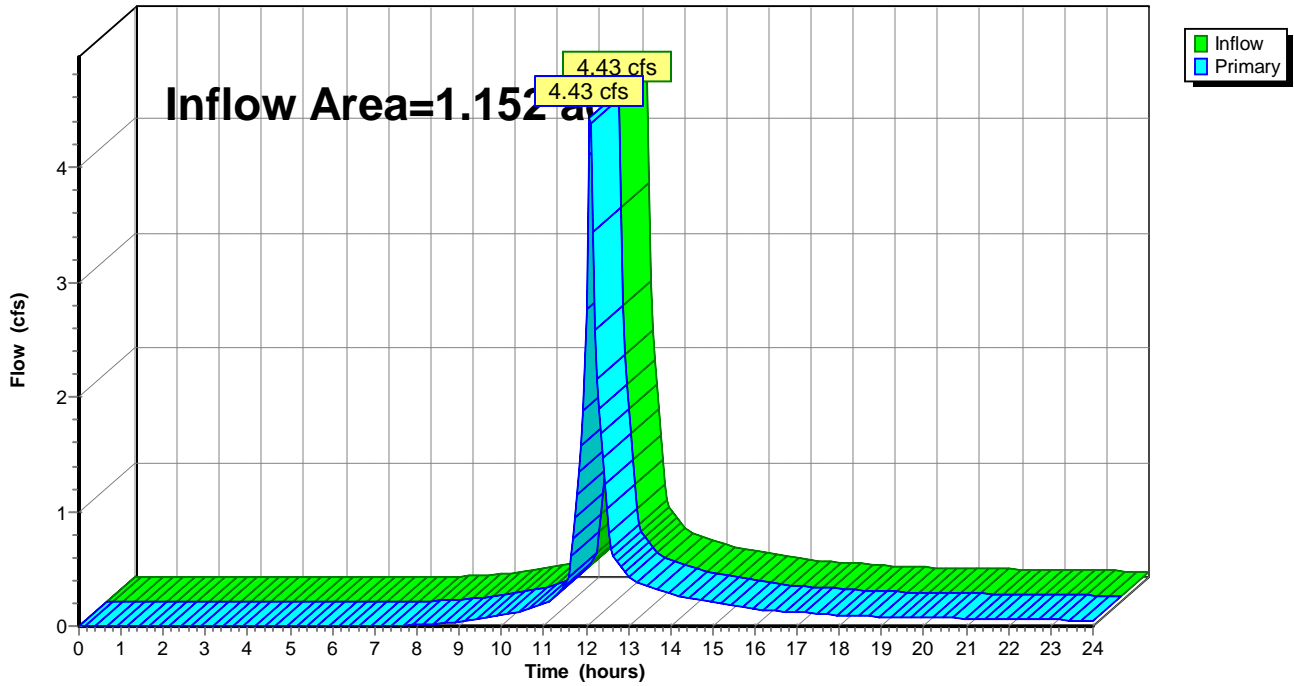

Time span=0.00-24.00 hrs, dt=0.05 hrs, 481 points
 Runoff by SCS TR-20 method, UH=SCS, Weighted-CN
 Reach routing by Stor-Ind+Trans method - Pond routing by Stor-Ind method

Subcatchment PRDA1D: PRDA-1	Runoff Area=360,934 sf 15.66% Impervious Runoff Depth>3.71" Flow Length=850' Tc=42.4 min CN=77 Runoff=17.36 cfs 2.562 af
Subcatchment PRDA1ND: PRDA-1	Runoff Area=430,511 sf 13.86% Impervious Runoff Depth>3.61" Flow Length=1,775' Tc=42.9 min CN=76 Runoff=20.01 cfs 2.972 af
Subcatchment PRDA2AND: PRDA-2A	Runoff Area=103,805 sf 0.00% Impervious Runoff Depth>3.22" Flow Length=400' Tc=24.1 min CN=72 Runoff=5.61 cfs 0.640 af
Subcatchment PRDA2BND: PRDA-2B	Runoff Area=85,134 sf 0.00% Impervious Runoff Depth>3.23" Flow Length=300' Tc=17.4 min CN=72 Runoff=5.26 cfs 0.526 af
Subcatchment PRDA3D: PRDA-3	Runoff Area=407,573 sf 36.10% Impervious Runoff Depth>4.37" Flow Length=1,450' Tc=6.7 min CN=83 Runoff=45.46 cfs 3.405 af
Subcatchment PRDA3ND: PRDA-3	Runoff Area=21,688 sf 76.07% Impervious Runoff Depth>5.36" Flow Length=100' Slope=0.1100 '/ Tc=5.0 min CN=92 Runoff=2.94 cfs 0.222 af
Subcatchment PRDA4ND: PRDA-4	Runoff Area=9,707 sf 20.57% Impervious Runoff Depth>3.95" Flow Length=100' Slope=0.1100 '/ Tc=5.0 min CN=79 Runoff=1.03 cfs 0.073 af
Subcatchment PRDA5ND: PRDA-5	Runoff Area=61,426 sf 22.51% Impervious Runoff Depth>3.95" Flow Length=300' Tc=5.7 min CN=79 Runoff=6.41 cfs 0.464 af
Subcatchment PRDA6ND: PRDA-6	Runoff Area=50,175 sf 19.16% Impervious Runoff Depth>3.95" Flow Length=650' Tc=5.6 min CN=79 Runoff=5.25 cfs 0.379 af
Pond BASIN A: BASIN A	Peak Elev=822.36' Storage=82,538 cf Inflow=45.46 cfs 3.405 af Outflow=4.14 cfs 2.494 af
Pond BASIN B: BASIN B	Peak Elev=823.86' Storage=36,215 cf Inflow=17.36 cfs 2.562 af Outflow=9.70 cfs 2.386 af
Link DP1: DP-1	Inflow=26.75 cfs 5.359 af Primary=26.75 cfs 5.359 af
Link DP2A: DP-2A	Inflow=5.61 cfs 0.640 af Primary=5.61 cfs 0.640 af
Link DP2B: DP-2B	Inflow=5.26 cfs 0.526 af Primary=5.26 cfs 0.526 af
Link DP3: DP-3	Inflow=4.62 cfs 2.716 af Primary=4.62 cfs 2.716 af
Link DP4: DP-4	Inflow=1.03 cfs 0.073 af Primary=1.03 cfs 0.073 af

Link DP5: DP-5

Inflow=6.41 cfs 0.464 af
Primary=6.41 cfs 0.464 af

Link DP6: DP-6

Inflow=5.25 cfs 0.379 af
Primary=5.25 cfs 0.379 af

Total Runoff Area = 35.146 ac Runoff Volume = 11.244 af Average Runoff Depth = 3.84"
80.06% Pervious = 28.138 ac 19.94% Impervious = 7.008 ac

Summary for Subcatchment PRDA1D: PRDA-1

Runoff = 17.36 cfs @ 12.58 hrs, Volume= 2.562 af, Depth> 3.71"

Runoff by SCS TR-20 method, UH=SCS, Weighted-CN, Time Span= 0.00-24.00 hrs, dt= 0.05 hrs
Type III 24-hr 50-Year Rainfall=6.30"

Area (sf)	CN	Description
36,718	98	Impervious, HSG C
1,151	98	Roofs, HSG C
18,667	98	Water Surface, HSG C
124,441	74	Pasture/grassland/range, Good, HSG C
* 115,820	75	Gravel, HSG C
64,137	70	Woods, Good, HSG C
360,934	77	Weighted Average
304,398		84.34% Pervious Area
56,536		15.66% Impervious Area

Tc (min)	Length (feet)	Slope (ft/ft)	Velocity (ft/sec)	Capacity (cfs)	Description
37.0	250	0.0320	0.11		Sheet Flow, Woods: Light underbrush n= 0.400 P2= 3.20"
5.4	600	0.0700	1.85		Shallow Concentrated Flow, Short Grass Pasture Kv= 7.0 fps
42.4	850	Total			

Subcatchment PRDA1D: PRDA-1

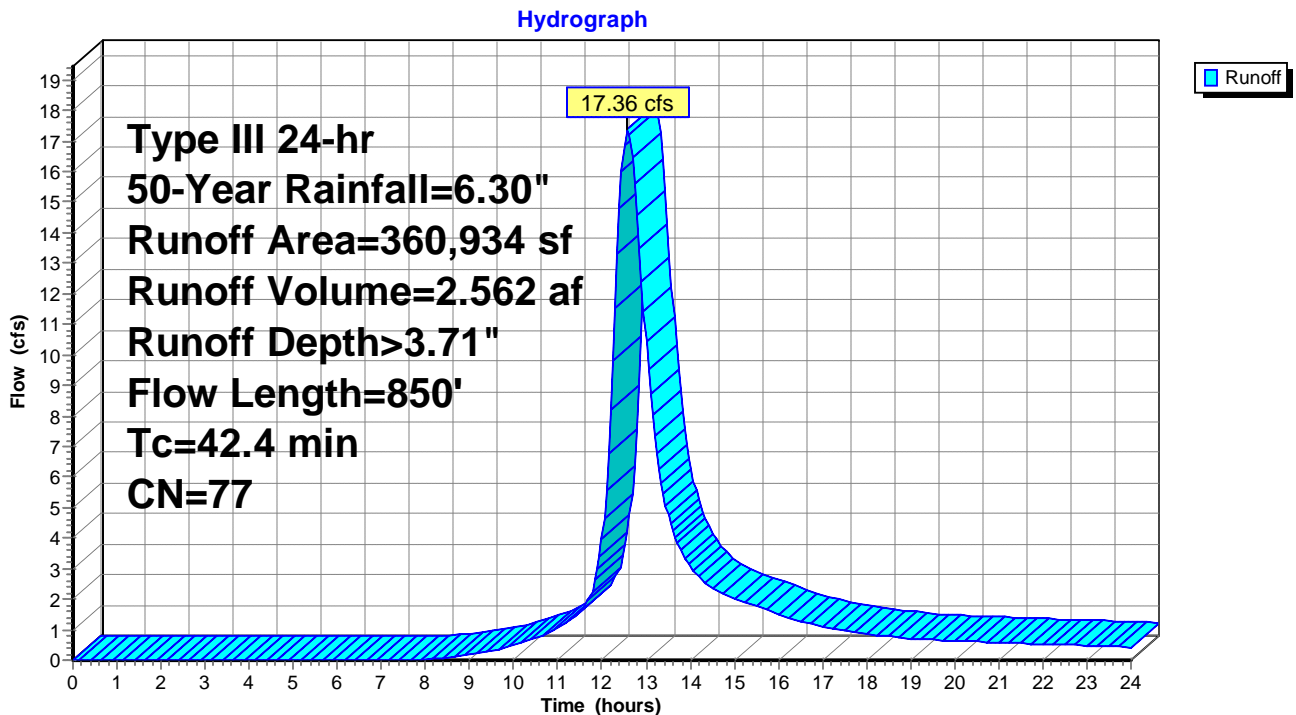

Summary for Subcatchment PRDA1ND: PRDA-1

Runoff = 20.01 cfs @ 12.59 hrs, Volume= 2.972 af, Depth> 3.61"

Runoff by SCS TR-20 method, UH=SCS, Weighted-CN, Time Span= 0.00-24.00 hrs, dt= 0.05 hrs
 Type III 24-hr 50-Year Rainfall=6.30"

Area (sf)	CN	Description
114,584	70	Woods, Good, HSG C
256,245	74	Pasture/grassland/range, Good, HSG C
59,682	98	Impervious, HSG C
430,511	76	Weighted Average
370,829		86.14% Pervious Area
59,682		13.86% Impervious Area

Tc (min)	Length (feet)	Slope (ft/ft)	Velocity (ft/sec)	Capacity (cfs)	Description
37.0	250	0.0320	0.11		Sheet Flow, Woods: Light underbrush n= 0.400 P2= 3.20"
4.9	1,000	0.0440	3.38		Shallow Concentrated Flow, Unpaved Kv= 16.1 fps
1.0	525	0.0570	8.87	53.22	Channel Flow, Area= 6.0 sf Perim= 6.0' r= 1.00' n= 0.040 Earth, cobble bottom, clean sides

42.9 1,775 Total

Subcatchment PRDA1ND: PRDA-1

Hydrograph

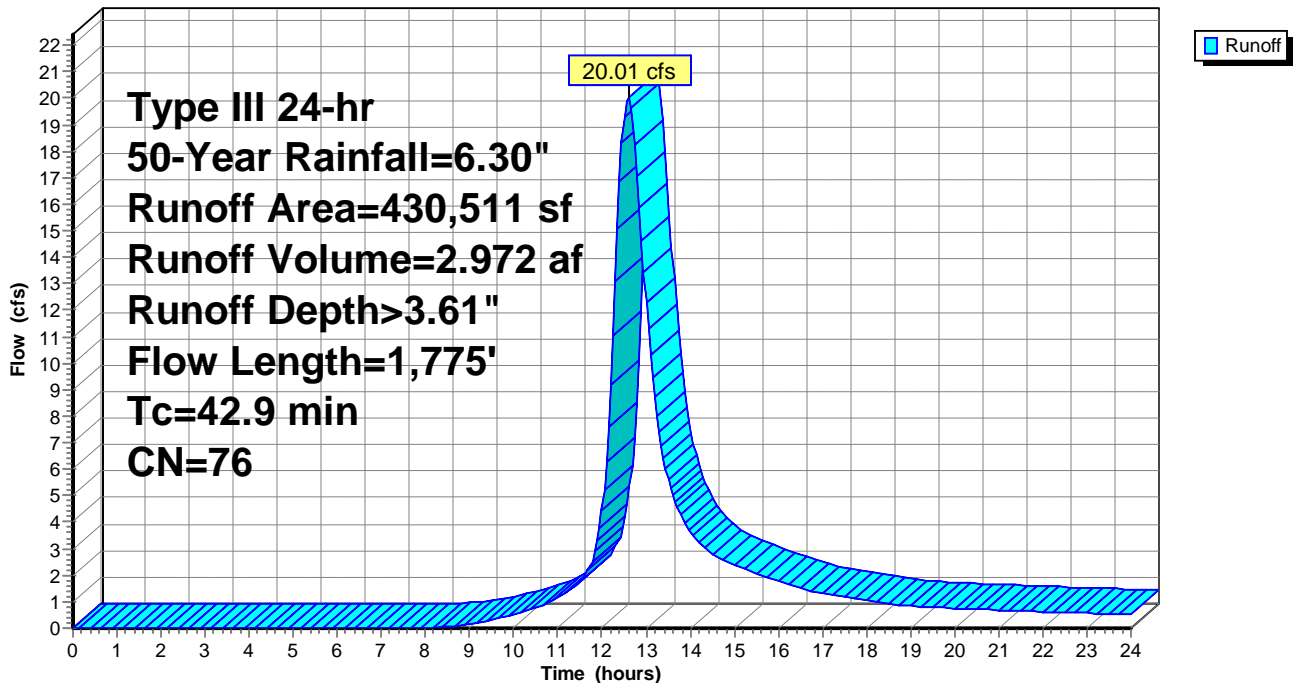

Summary for Subcatchment PRDA2AND: PRDA-2A

Runoff = 5.61 cfs @ 12.34 hrs, Volume= 0.640 af, Depth> 3.22"

Runoff by SCS TR-20 method, UH=SCS, Weighted-CN, Time Span= 0.00-24.00 hrs, dt= 0.05 hrs
 Type III 24-hr 50-Year Rainfall=6.30"

Area (sf)	CN	Description
46,490	70	Woods, Good, HSG C
57,315	74	Pasture/grassland/range, Good, HSG C
103,805	72	Weighted Average
103,805		100.00% Pervious Area

Tc (min)	Length (feet)	Slope (ft/ft)	Velocity (ft/sec)	Capacity (cfs)	Description
23.1	250	0.1040	0.18		Sheet Flow, Woods: Light underbrush n= 0.400 P2= 3.20"
1.0	150	0.2400	2.45		Shallow Concentrated Flow, Woodland Kv= 5.0 fps
24.1	400	Total			

Subcatchment PRDA2AND: PRDA-2A

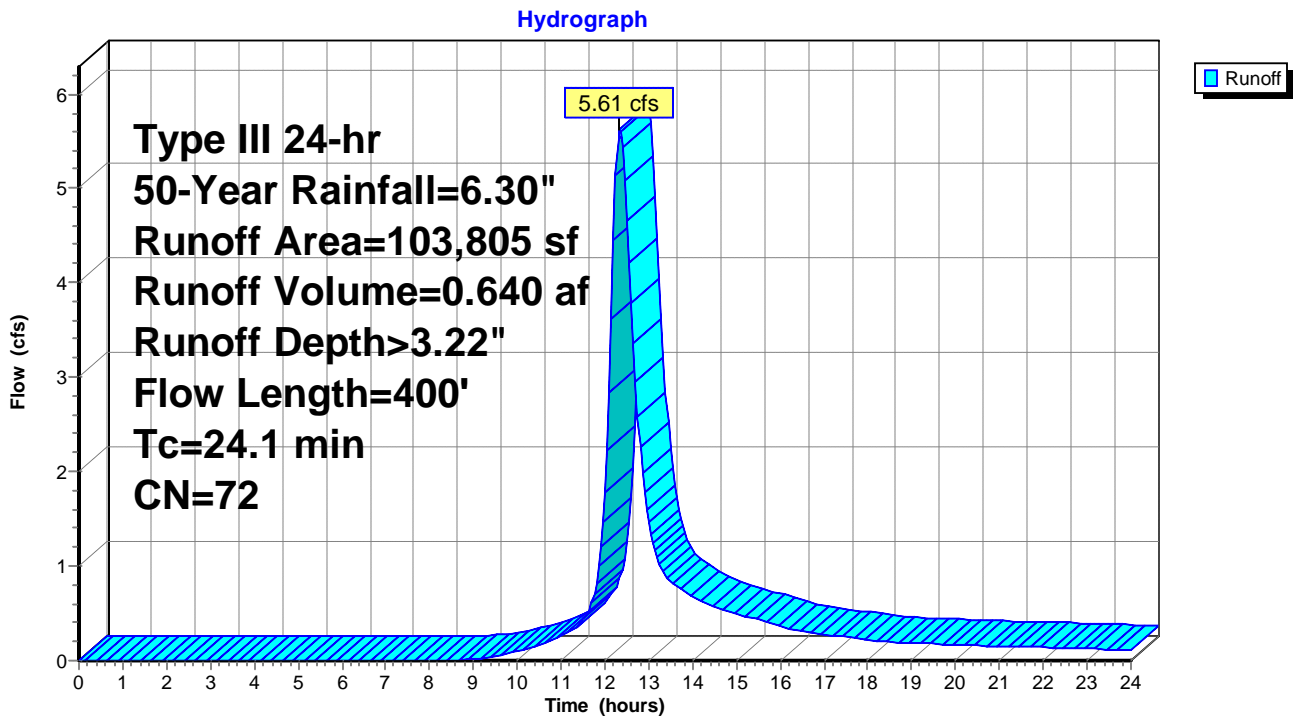

Summary for Subcatchment PRDA2BND: PRDA-2B

Runoff = 5.26 cfs @ 12.25 hrs, Volume= 0.526 af, Depth> 3.23"

Runoff by SCS TR-20 method, UH=SCS, Weighted-CN, Time Span= 0.00-24.00 hrs, dt= 0.05 hrs
 Type III 24-hr 50-Year Rainfall=6.30"

Area (sf)	CN	Description
33,200	70	Woods, Good, HSG C
51,934	74	Pasture/grassland/range, Good, HSG C
85,134	72	Weighted Average
85,134		100.00% Pervious Area

Tc (min)	Length (feet)	Slope (ft/ft)	Velocity (ft/sec)	Capacity (cfs)	Description
16.1	200	0.1650	0.21		Sheet Flow, Woods: Light underbrush n= 0.400 P2= 3.20"
1.3	100	0.0700	1.32		Shallow Concentrated Flow, Woodland Kv= 5.0 fps
17.4	300	Total			

Subcatchment PRDA2BND: PRDA-2B

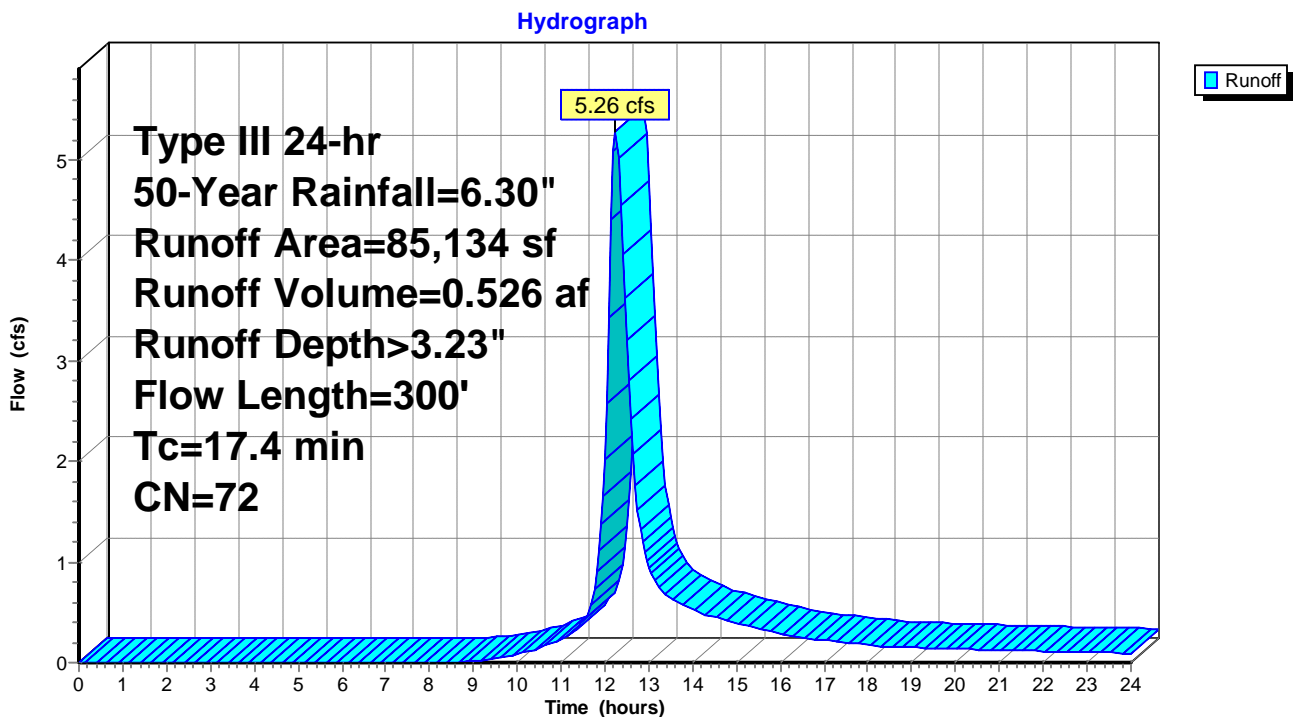

Summary for Subcatchment PRDA3D: PRDA-3

Runoff = 45.46 cfs @ 12.10 hrs, Volume= 3.405 af, Depth> 4.37"

Runoff by SCS TR-20 method, UH=SCS, Weighted-CN, Time Span= 0.00-24.00 hrs, dt= 0.05 hrs
 Type III 24-hr 50-Year Rainfall=6.30"

Area (sf)	CN	Description
69,087	98	Impervious, HSG C
36,569	98	Roofs, HSG C
41,458	98	Water Surface, HSG C
* 260,459	75	Gravel, HSG C
407,573	83	Weighted Average
260,459		63.90% Pervious Area
147,114		36.10% Impervious Area

Tc (min)	Length (feet)	Slope (ft/ft)	Velocity (ft/sec)	Capacity (cfs)	Description
3.3	250	0.0100	1.25		Sheet Flow, Smooth surfaces n= 0.011 P2= 3.20"
3.4	1,200	0.0075	5.93	7.27	Pipe Channel, 15.0" Round Area= 1.2 sf Perim= 3.9' r= 0.31' n= 0.010 PVC, smooth interior
6.7	1,450	Total			

Subcatchment PRDA3D: PRDA-3

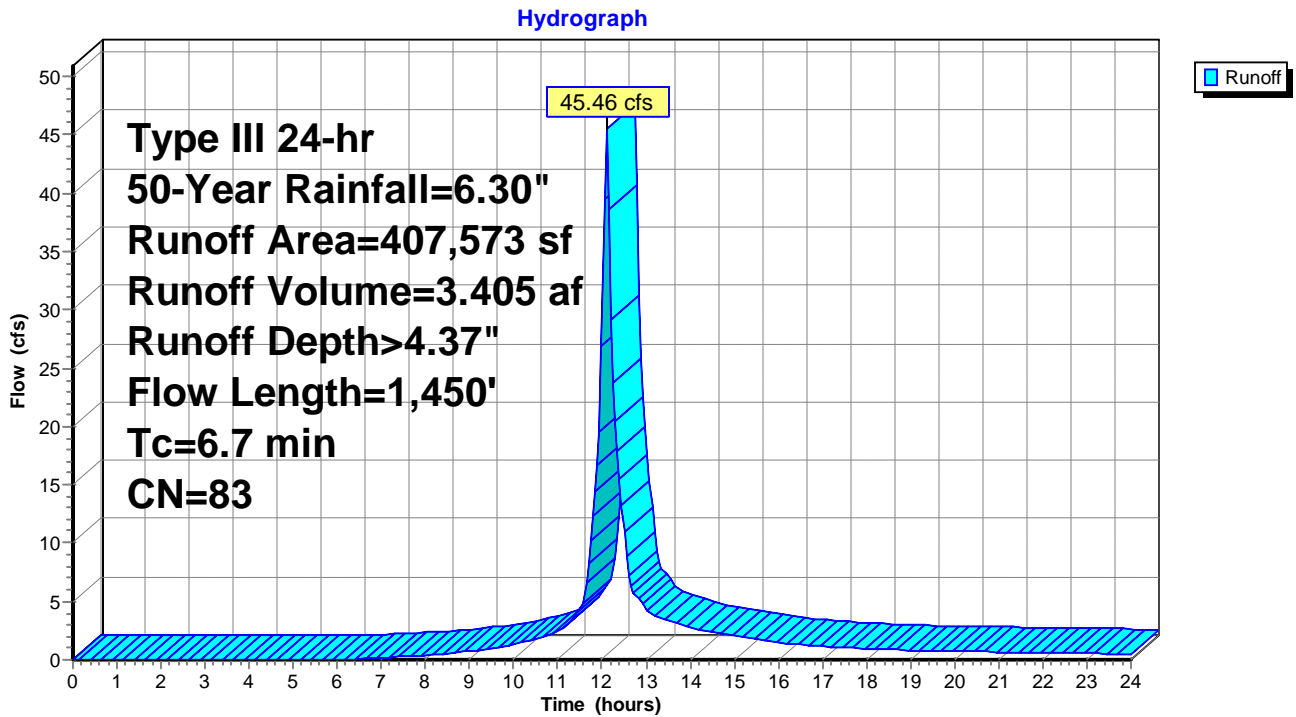

Summary for Subcatchment PRDA3ND: PRDA-3

Runoff = 2.94 cfs @ 12.07 hrs, Volume= 0.222 af, Depth> 5.36"

Runoff by SCS TR-20 method, UH=SCS, Weighted-CN, Time Span= 0.00-24.00 hrs, dt= 0.05 hrs
 Type III 24-hr 50-Year Rainfall=6.30"

Area (sf)	CN	Description
5,191	74	Pasture/grassland/range, Good, HSG C
16,497	98	Impervious, HSG C
21,688	92	Weighted Average
5,191		23.93% Pervious Area
16,497		76.07% Impervious Area

Tc (min)	Length (feet)	Slope (ft/ft)	Velocity (ft/sec)	Capacity (cfs)	Description
5.0	100	0.1100	0.34		Sheet Flow, Grass: Short n= 0.150 P2= 3.20"

Subcatchment PRDA3ND: PRDA-3

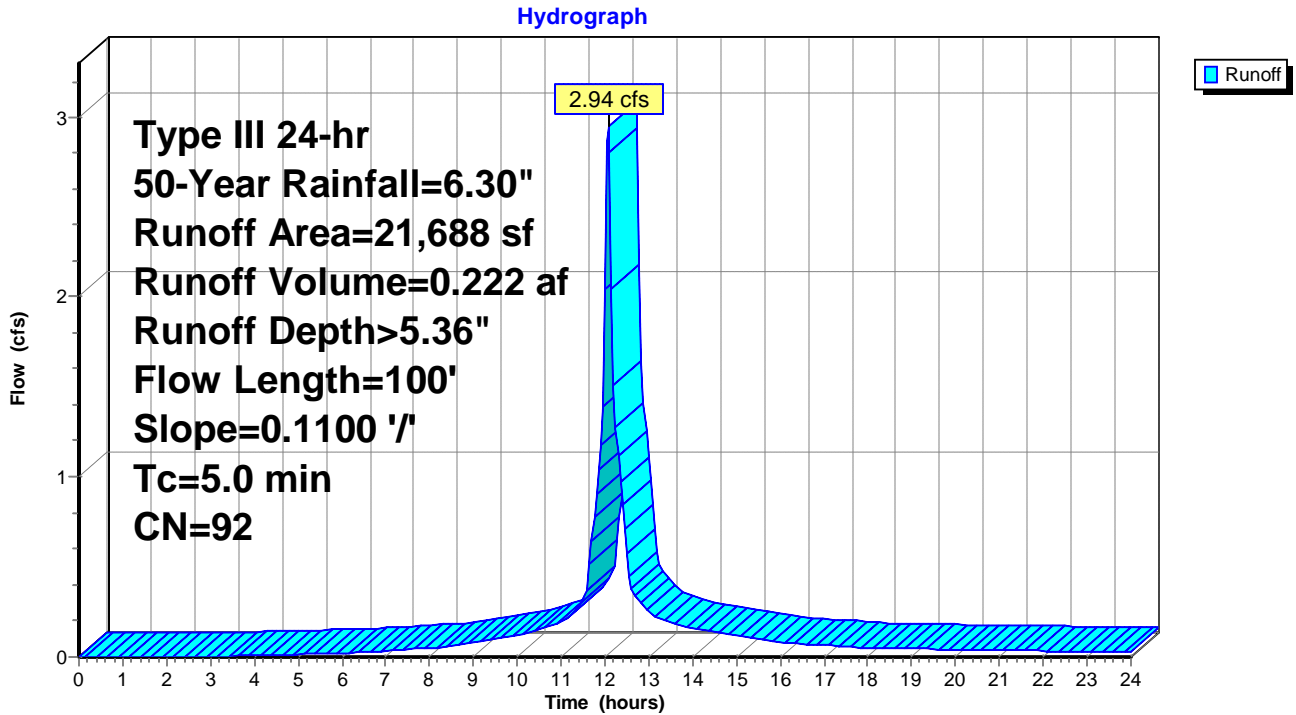

Summary for Subcatchment PRDA4ND: PRDA-4

Runoff = 1.03 cfs @ 12.08 hrs, Volume= 0.073 af, Depth> 3.95"

Runoff by SCS TR-20 method, UH=SCS, Weighted-CN, Time Span= 0.00-24.00 hrs, dt= 0.05 hrs
 Type III 24-hr 50-Year Rainfall=6.30"

Area (sf)	CN	Description
7,710	74	Pasture/grassland/range, Good, HSG C
* 1,997	98	Impervious
9,707	79	Weighted Average
7,710		79.43% Pervious Area
1,997		20.57% Impervious Area

Tc (min)	Length (feet)	Slope (ft/ft)	Velocity (ft/sec)	Capacity (cfs)	Description
5.0	100	0.1100	0.34		Sheet Flow, Grass: Short n= 0.150 P2= 3.20"

Subcatchment PRDA4ND: PRDA-4

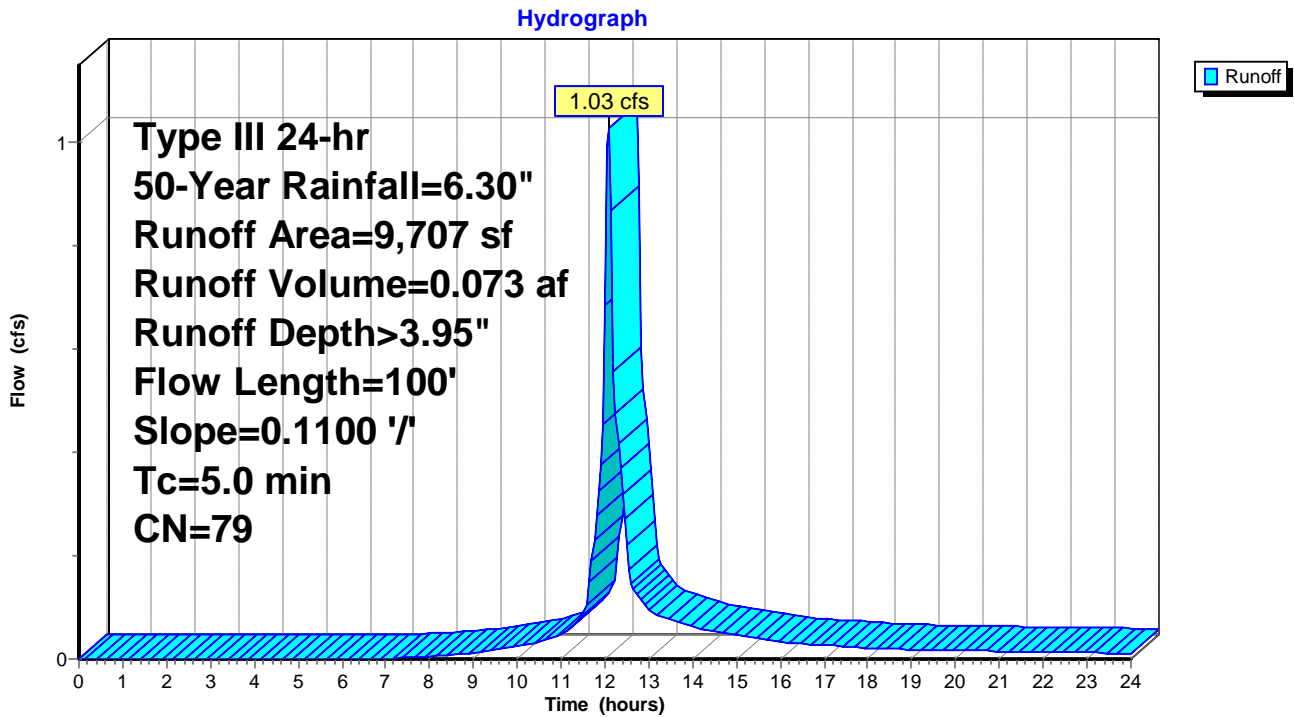

Summary for Subcatchment PRDA5ND: PRDA-5

Runoff = 6.41 cfs @ 12.09 hrs, Volume= 0.464 af, Depth> 3.95"

Runoff by SCS TR-20 method, UH=SCS, Weighted-CN, Time Span= 0.00-24.00 hrs, dt= 0.05 hrs
 Type III 24-hr 50-Year Rainfall=6.30"

Area (sf)	CN	Description
13,824	98	Impervious, HSG C
47,602	74	Pasture/grassland/range, Good, HSG C
61,426	79	Weighted Average
47,602		77.49% Pervious Area
13,824		22.51% Impervious Area

Tc (min)	Length (feet)	Slope (ft/ft)	Velocity (ft/sec)	Capacity (cfs)	Description
5.5	200	0.3333	0.60		Sheet Flow, Grass: Short n= 0.150 P2= 3.20"
0.2	100	0.0100	6.84	8.40	Pipe Channel, 15.0" Round Area= 1.2 sf Perim= 3.9' r= 0.31' n= 0.010 PVC, smooth interior
5.7	300	Total			

Subcatchment PRDA5ND: PRDA-5

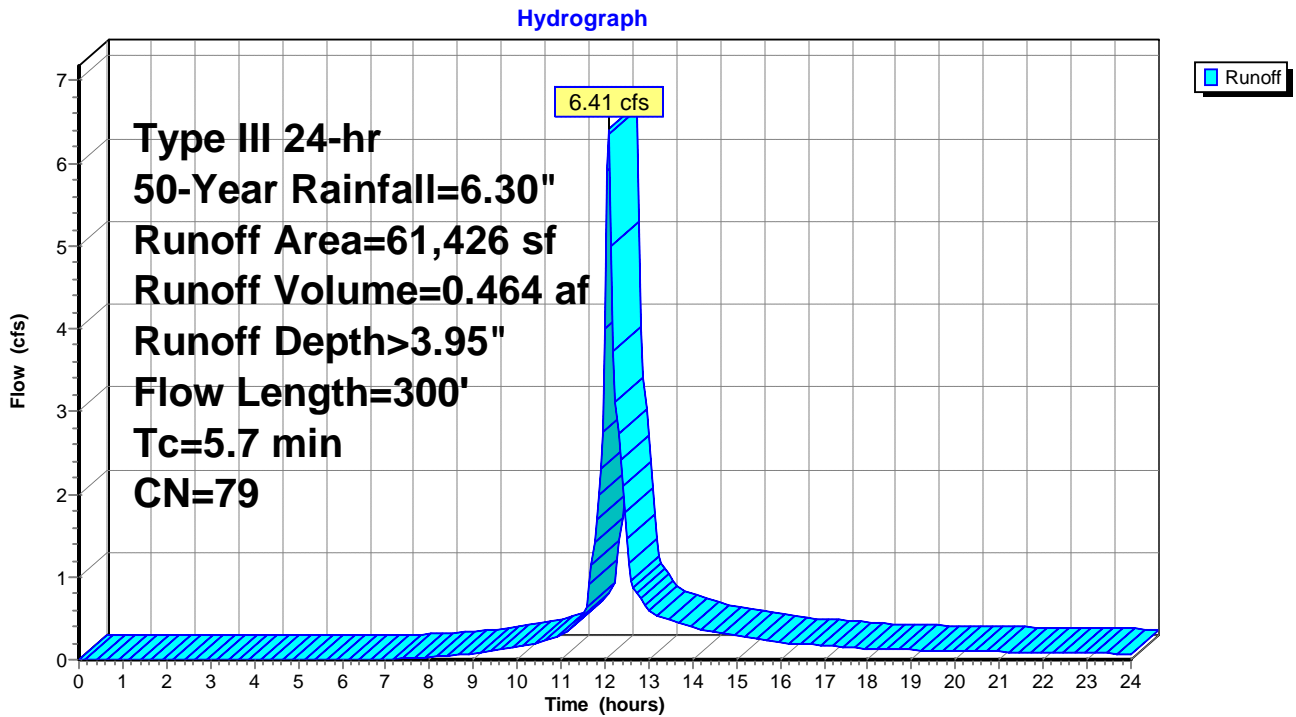

Summary for Subcatchment PRDA6ND: PRDA-6

Runoff = 5.25 cfs @ 12.09 hrs, Volume= 0.379 af, Depth> 3.95"

Runoff by SCS TR-20 method, UH=SCS, Weighted-CN, Time Span= 0.00-24.00 hrs, dt= 0.05 hrs
 Type III 24-hr 50-Year Rainfall=6.30"

Area (sf)	CN	Description
40,563	74	Pasture/grassland/range, Good, HSG C
9,612	98	Impervious, HSG C
50,175	79	Weighted Average
40,563		80.84% Pervious Area
9,612		19.16% Impervious Area

Tc (min)	Length (feet)	Slope (ft/ft)	Velocity (ft/sec)	Capacity (cfs)	Description
4.4	150	0.3333	0.57		Sheet Flow, Grass: Short n= 0.150 P2= 3.20"
1.2	500	0.2050	6.79		Shallow Concentrated Flow, Grassed Waterway Kv= 15.0 fps
5.6	650	Total			

Subcatchment PRDA6ND: PRDA-6

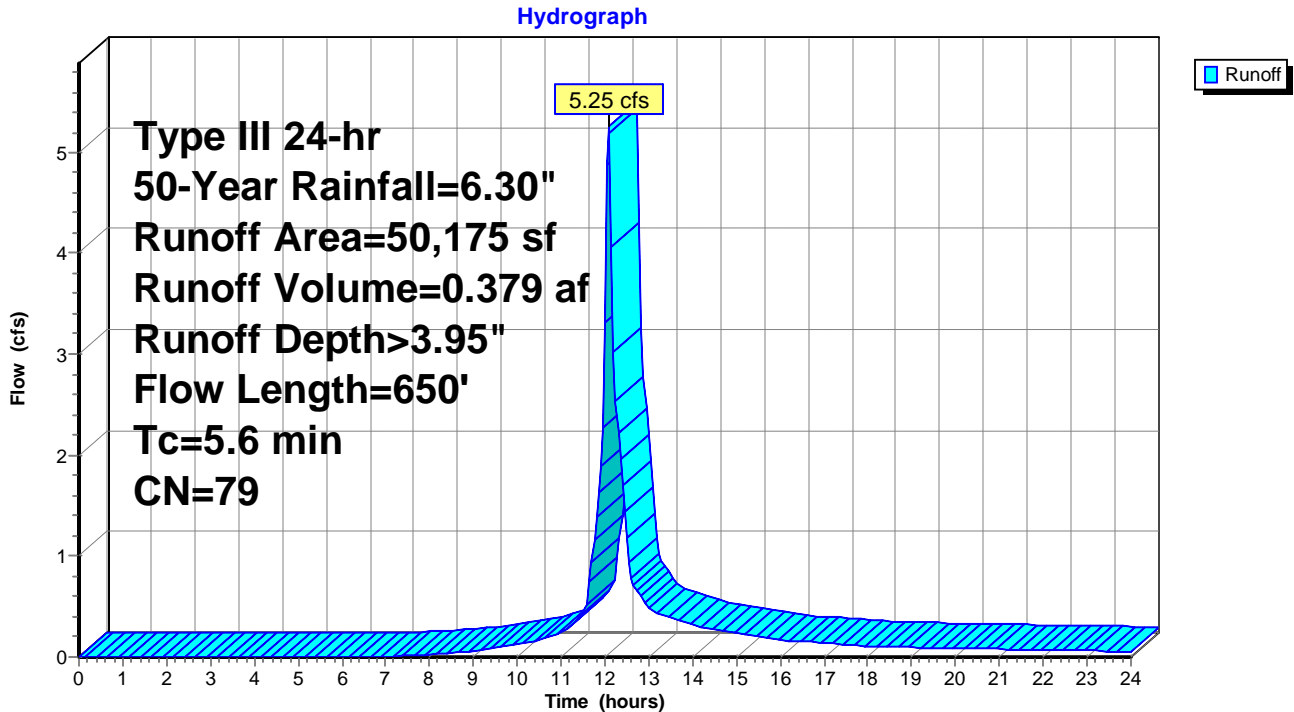

Summary for Pond BASIN A: BASIN A

Inflow Area = 9.357 ac, 36.10% Impervious, Inflow Depth > 4.37" for 50-Year event
 Inflow = 45.46 cfs @ 12.10 hrs, Volume= 3.405 af
 Outflow = 4.14 cfs @ 13.06 hrs, Volume= 2.494 af, Atten= 91%, Lag= 57.5 min
 Primary = 4.14 cfs @ 13.06 hrs, Volume= 2.494 af

Routing by Stor-Ind method, Time Span= 0.00-24.00 hrs, dt= 0.05 hrs
 Peak Elev= 822.36' @ 13.06 hrs Surf.Area= 39,130 sf Storage= 82,538 cf

Plug-Flow detention time= 294.7 min calculated for 2.494 af (73% of inflow)
 Center-of-Mass det. time= 206.9 min (1,011.4 - 804.4)

Volume	Invert	Avail.Storage	Storage Description
#1	820.00'	151,470 cf	Basin A (Irregular) Listed below (Recalc)

Elevation (feet)	Surf.Area (sq-ft)	Perim. (feet)	Inc.Store (cubic-feet)	Cum.Store (cubic-feet)	Wet.Area (sq-ft)
820.00	30,856	1,150.0	0	0	30,856
822.00	37,867	1,187.0	68,603	68,603	38,123
824.00	45,105	1,225.0	82,867	151,470	45,805

Device	Routing	Invert	Outlet Devices
#1	Primary	820.00'	15.0" Round Culvert L= 250.0' Ke= 0.500 Inlet / Outlet Invert= 820.00' / 786.00' S= 0.1360 '/' Cc= 0.900 n= 0.010 PVC, smooth interior, Flow Area= 1.23 sf
#2	Device 1	820.00'	8.0" Vert. Orifice/Grate C= 0.600
#3	Device 1	822.00'	15.0" W x 12.0" H Vert. Orifice/Grate X 2.00 C= 0.600

Primary OutFlow Max=4.14 cfs @ 13.06 hrs HW=822.36' (Free Discharge)

- 1=Culvert (Passes 4.14 cfs of 7.79 cfs potential flow)
- 2=Orifice/Grate (Orifice Controls 2.39 cfs @ 6.86 fps)
- 3=Orifice/Grate (Orifice Controls 1.75 cfs @ 1.93 fps)

Pond BASIN A: BASIN A

Hydrograph

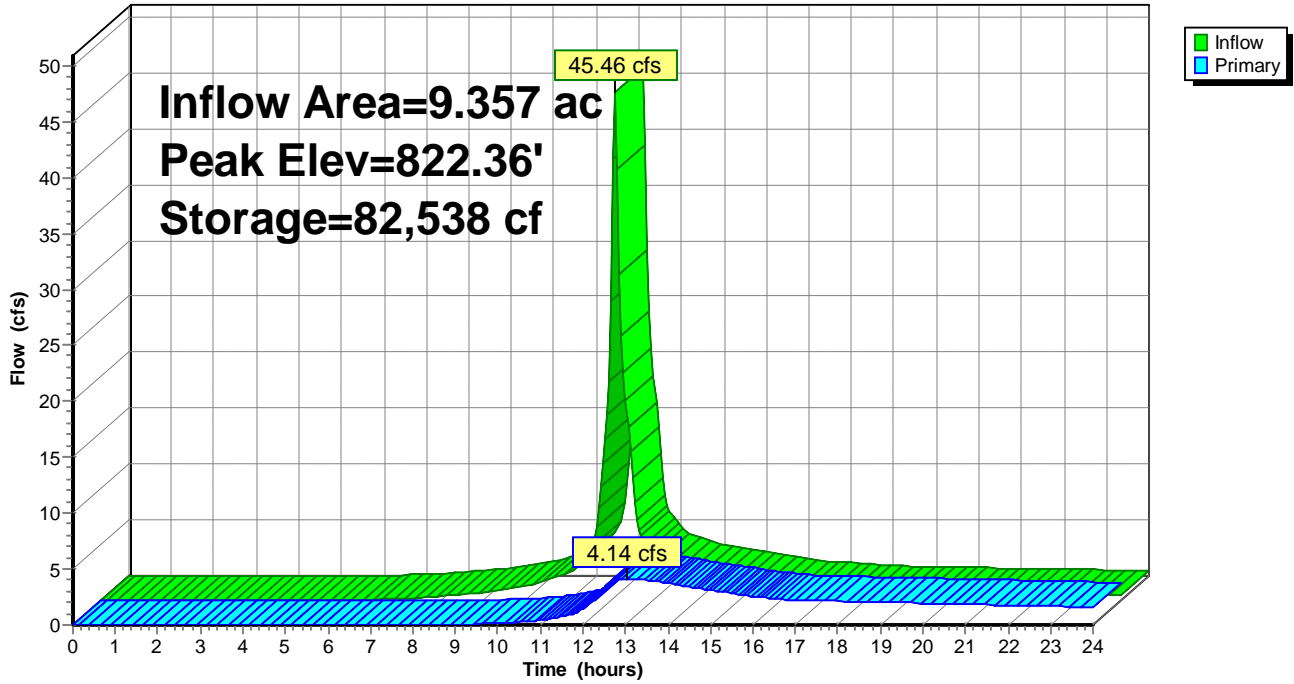

Summary for Pond BASIN B: BASIN B

Inflow Area = 8.286 ac, 15.66% Impervious, Inflow Depth > 3.71" for 50-Year event
 Inflow = 17.36 cfs @ 12.58 hrs, Volume= 2.562 af
 Outflow = 9.70 cfs @ 13.04 hrs, Volume= 2.386 af, Atten= 44%, Lag= 27.5 min
 Primary = 9.70 cfs @ 13.04 hrs, Volume= 2.386 af

Routing by Stor-Ind method, Time Span= 0.00-24.00 hrs, dt= 0.05 hrs
 Peak Elev= 823.86' @ 13.04 hrs Surf.Area= 15,948 sf Storage= 36,215 cf

Plug-Flow detention time= 103.5 min calculated for 2.386 af (93% of inflow)
 Center-of-Mass det. time= 69.3 min (917.4 - 848.1)

Volume	Invert	Avail.Storage	Storage Description		
#1	821.00'	122,878 cf	Basin B (Irregular) Listed below (Recalc)		
Elevation (feet)	Surf.Area (sq-ft)	Perim. (feet)	Inc.Store (cubic-feet)	Cum.Store (cubic-feet)	Wet.Area (sq-ft)
821.00	9,468	729.0	0	0	9,468
822.00	11,682	748.0	10,556	10,556	11,820
824.00	16,283	786.0	27,838	38,394	16,706
826.00	21,113	824.1	37,292	75,685	21,846
828.00	26,170	850.0	47,193	122,878	25,681

Device	Routing	Invert	Outlet Devices	
#1	Primary	821.00'	18.0" Round Culvert L= 100.0' Ke= 0.500 Inlet / Outlet Invert= 821.00' / 797.00' S= 0.2400 '/' Cc= 0.900 n= 0.010 PVC, smooth interior, Flow Area= 1.77 sf	
#2	Device 1	821.00'	6.0" Vert. Orifice/Grate C= 0.600	
#3	Device 1	822.00'	12.0" W x 30.0" H Vert. Orifice/Grate C= 0.600	
#4	Primary	825.00'	24.0" Vert. Orifice/Grate C= 0.600	

Primary OutFlow Max=9.70 cfs @ 13.04 hrs HW=823.86' (Free Discharge)

- 1=Culvert (Passes 9.70 cfs of 12.37 cfs potential flow)
- 2=Orifice/Grate (Orifice Controls 1.53 cfs @ 7.79 fps)
- 3=Orifice/Grate (Orifice Controls 8.17 cfs @ 4.38 fps)
- 4=Orifice/Grate (Controls 0.00 cfs)

Pond BASIN B: BASIN B

Hydrograph

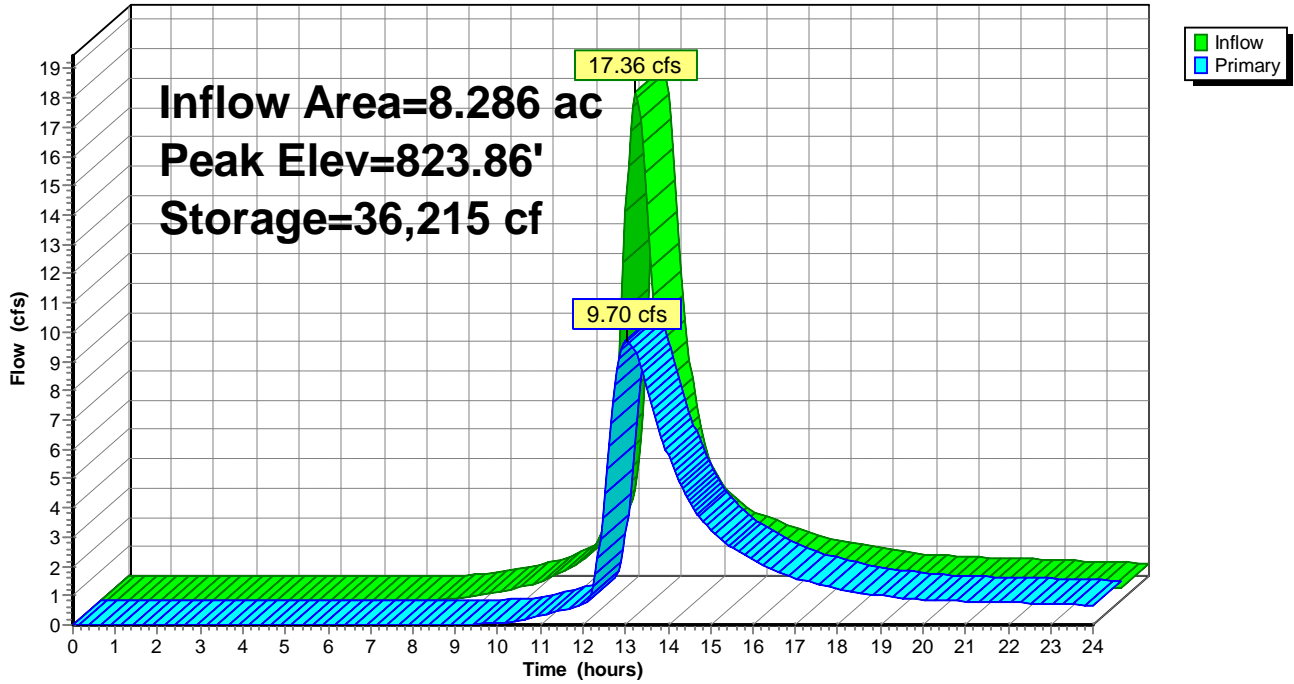

Summary for Link DP1: DP-1

Inflow Area = 18.169 ac, 14.68% Impervious, Inflow Depth > 3.54" for 50-Year event
Inflow = 26.75 cfs @ 12.69 hrs, Volume= 5.359 af
Primary = 26.75 cfs @ 12.69 hrs, Volume= 5.359 af, Atten= 0%, Lag= 0.0 min

Primary outflow = Inflow, Time Span= 0.00-24.00 hrs, dt= 0.05 hrs

Link DP1: DP-1

Hydrograph

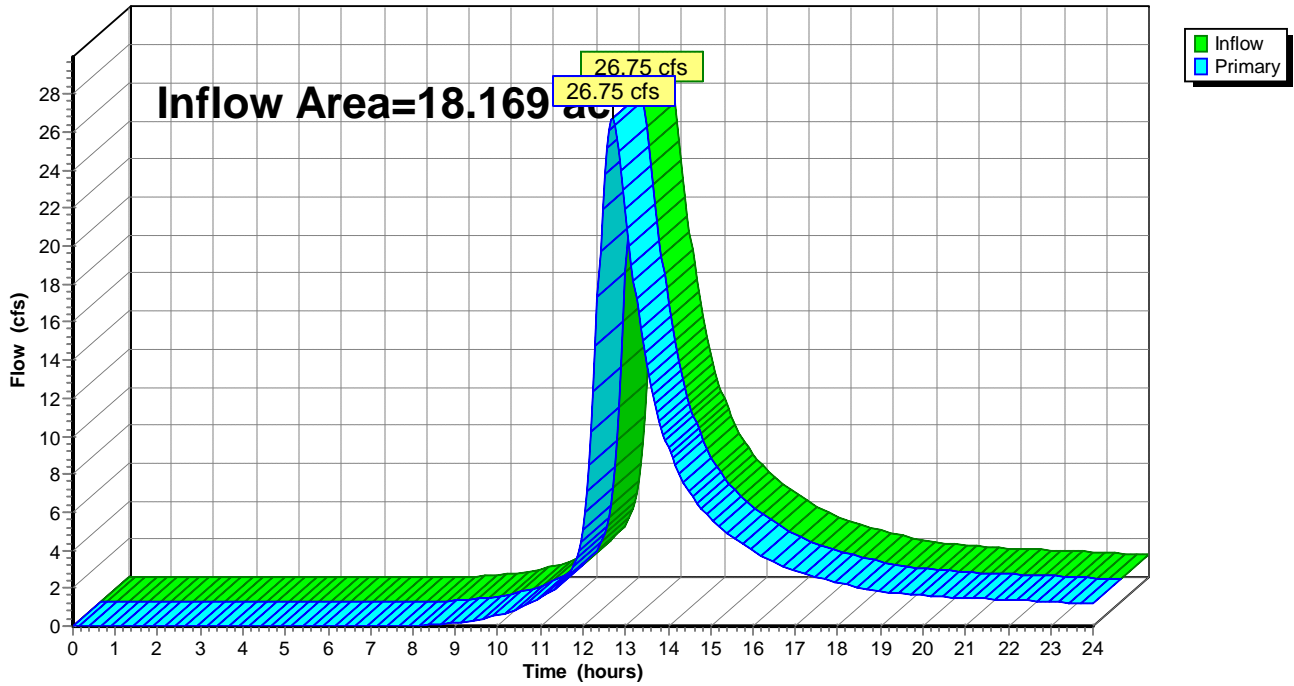

Summary for Link DP2A: DP-2A

Inflow Area = 2.383 ac, 0.00% Impervious, Inflow Depth > 3.22" for 50-Year event
Inflow = 5.61 cfs @ 12.34 hrs, Volume= 0.640 af
Primary = 5.61 cfs @ 12.34 hrs, Volume= 0.640 af, Atten= 0%, Lag= 0.0 min

Primary outflow = Inflow, Time Span= 0.00-24.00 hrs, dt= 0.05 hrs

Link DP2A: DP-2A

Hydrograph

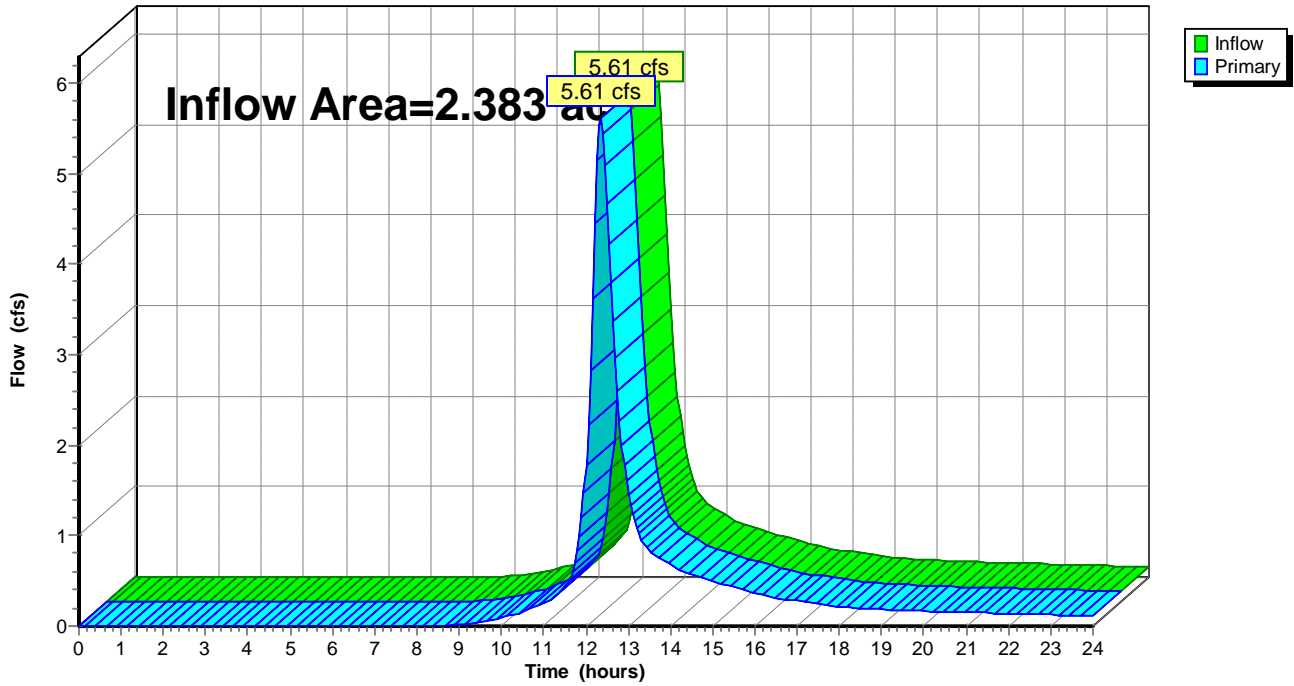

Summary for Link DP2B: DP-2B

Inflow Area = 1.954 ac, 0.00% Impervious, Inflow Depth > 3.23" for 50-Year event
Inflow = 5.26 cfs @ 12.25 hrs, Volume= 0.526 af
Primary = 5.26 cfs @ 12.25 hrs, Volume= 0.526 af, Atten= 0%, Lag= 0.0 min

Primary outflow = Inflow, Time Span= 0.00-24.00 hrs, dt= 0.05 hrs

Link DP2B: DP-2B

Hydrograph

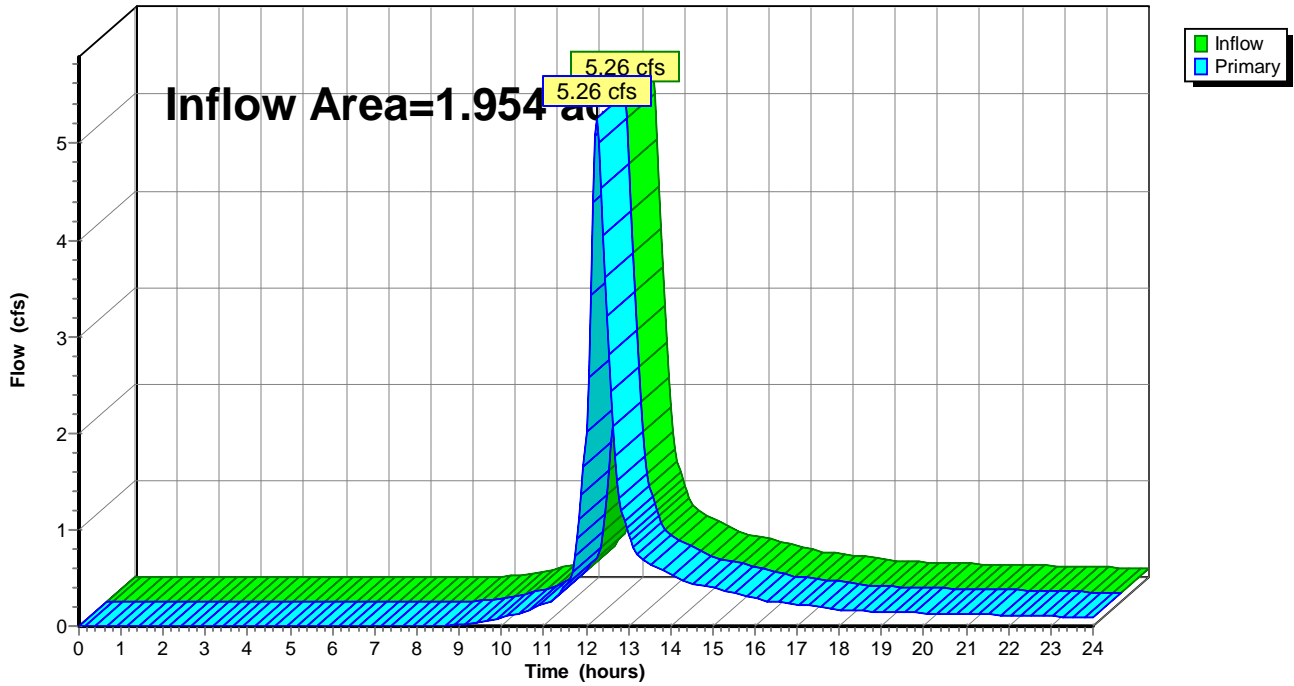

Summary for Link DP3: DP-3

Inflow Area = 9.854 ac, 38.11% Impervious, Inflow Depth > 3.31" for 50-Year event
Inflow = 4.62 cfs @ 12.08 hrs, Volume= 2.716 af
Primary = 4.62 cfs @ 12.08 hrs, Volume= 2.716 af, Atten= 0%, Lag= 0.0 min

Primary outflow = Inflow, Time Span= 0.00-24.00 hrs, dt= 0.05 hrs

Link DP3: DP-3

Hydrograph

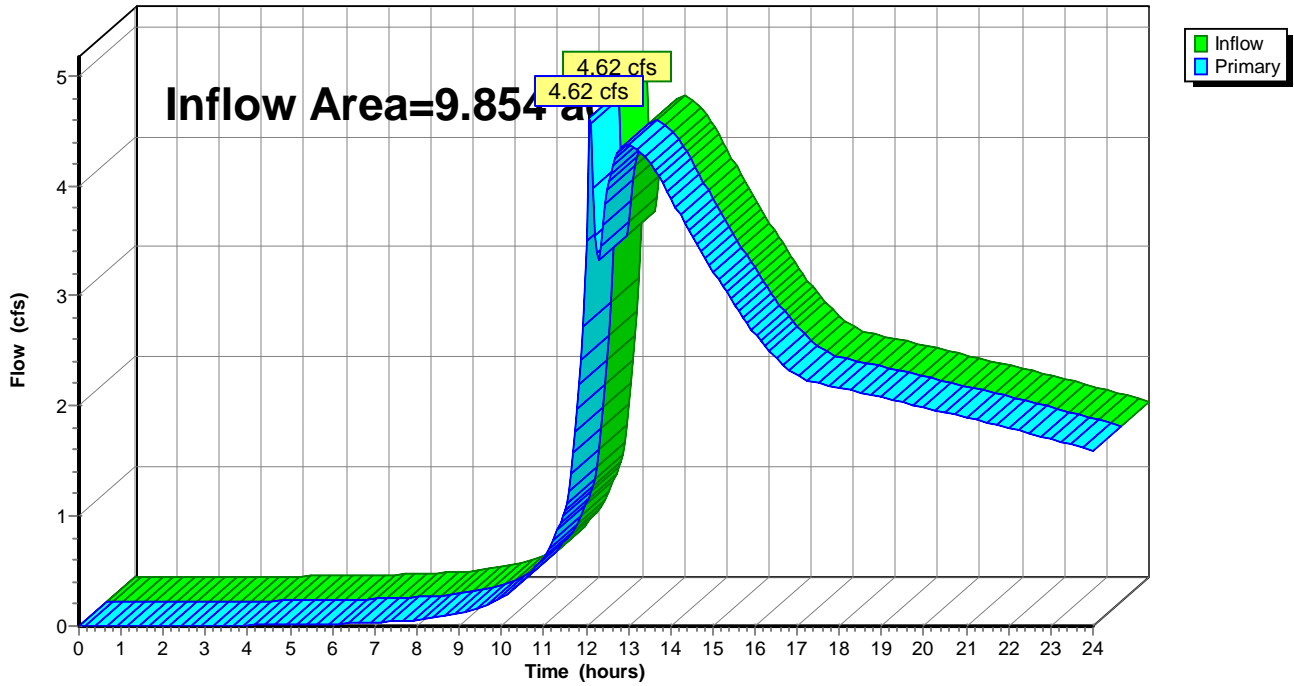

Summary for Link DP4: DP-4

Inflow Area = 0.223 ac, 20.57% Impervious, Inflow Depth > 3.95" for 50-Year event
Inflow = 1.03 cfs @ 12.08 hrs, Volume= 0.073 af
Primary = 1.03 cfs @ 12.08 hrs, Volume= 0.073 af, Atten= 0%, Lag= 0.0 min

Primary outflow = Inflow, Time Span= 0.00-24.00 hrs, dt= 0.05 hrs

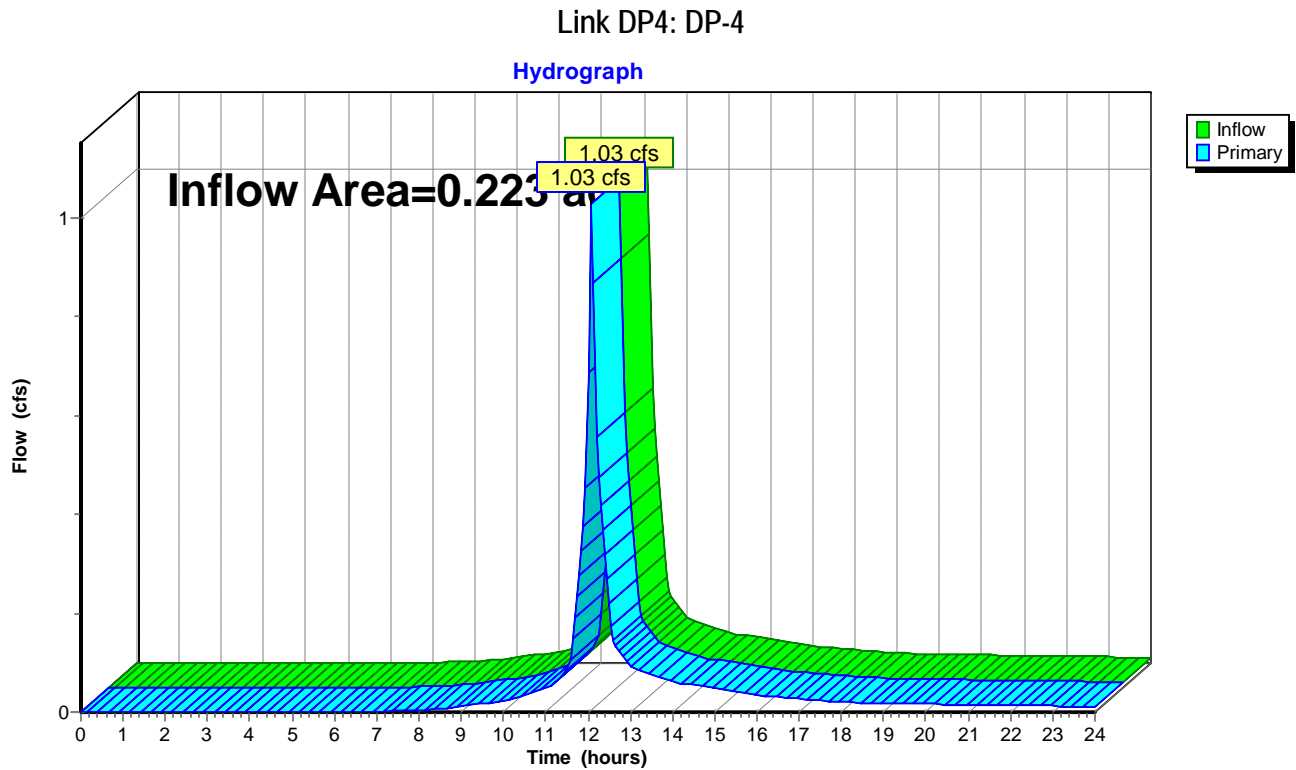

Summary for Link DP5: DP-5

Inflow Area = 1.410 ac, 22.51% Impervious, Inflow Depth > 3.95" for 50-Year event
Inflow = 6.41 cfs @ 12.09 hrs, Volume= 0.464 af
Primary = 6.41 cfs @ 12.09 hrs, Volume= 0.464 af, Atten= 0%, Lag= 0.0 min

Primary outflow = Inflow, Time Span= 0.00-24.00 hrs, dt= 0.05 hrs

Link DP5: DP-5

Hydrograph

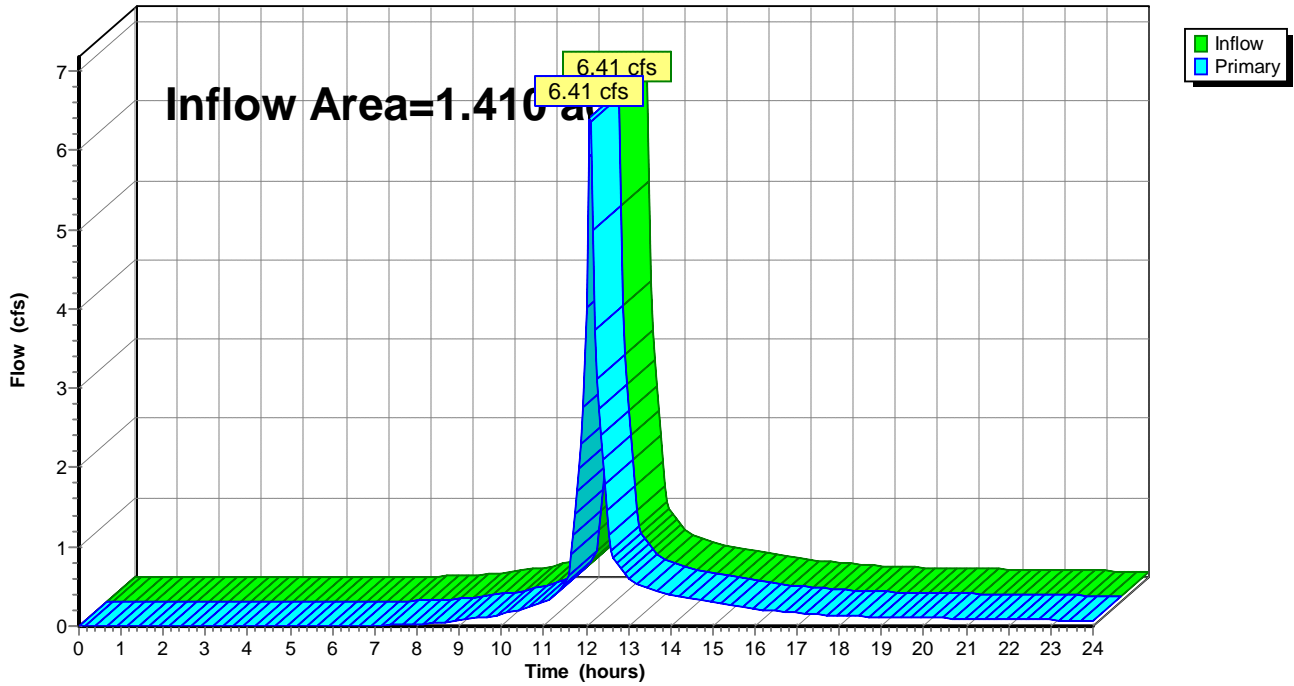

Summary for Link DP6: DP-6

Inflow Area = 1.152 ac, 19.16% Impervious, Inflow Depth > 3.95" for 50-Year event
Inflow = 5.25 cfs @ 12.09 hrs, Volume= 0.379 af
Primary = 5.25 cfs @ 12.09 hrs, Volume= 0.379 af, Atten= 0%, Lag= 0.0 min

Primary outflow = Inflow, Time Span= 0.00-24.00 hrs, dt= 0.05 hrs

Link DP6: DP-6

Hydrograph

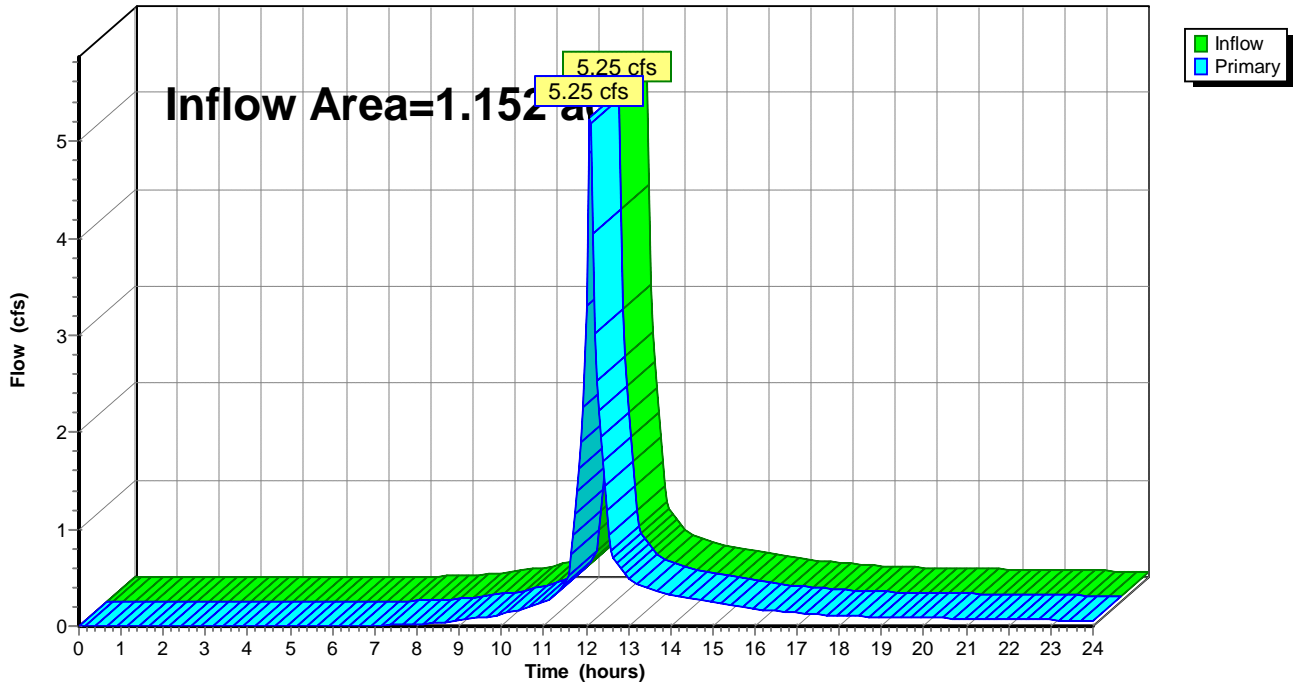

Time span=0.00-24.00 hrs, dt=0.05 hrs, 481 points
 Runoff by SCS TR-20 method, UH=SCS, Weighted-CN
 Reach routing by Stor-Ind+Trans method - Pond routing by Stor-Ind method

Subcatchment PRDA1D: PRDA-1	Runoff Area=360,934 sf 15.66% Impervious Runoff Depth>4.42" Flow Length=850' Tc=42.4 min CN=77 Runoff=20.64 cfs 3.052 af
Subcatchment PRDA1ND: PRDA-1	Runoff Area=430,511 sf 13.86% Impervious Runoff Depth>4.31" Flow Length=1,775' Tc=42.9 min CN=76 Runoff=23.87 cfs 3.550 af
Subcatchment PRDA2AND: PRDA-2A	Runoff Area=103,805 sf 0.00% Impervious Runoff Depth>3.90" Flow Length=400' Tc=24.1 min CN=72 Runoff=6.80 cfs 0.774 af
Subcatchment PRDA2BND: PRDA-2B	Runoff Area=85,134 sf 0.00% Impervious Runoff Depth>3.90" Flow Length=300' Tc=17.4 min CN=72 Runoff=6.37 cfs 0.635 af
Subcatchment PRDA3D: PRDA-3	Runoff Area=407,573 sf 36.10% Impervious Runoff Depth>5.12" Flow Length=1,450' Tc=6.7 min CN=83 Runoff=52.94 cfs 3.990 af
Subcatchment PRDA3ND: PRDA-3	Runoff Area=21,688 sf 76.07% Impervious Runoff Depth>6.15" Flow Length=100' Slope=0.1100 '/ Tc=5.0 min CN=92 Runoff=3.35 cfs 0.255 af
Subcatchment PRDA4ND: PRDA-4	Runoff Area=9,707 sf 20.57% Impervious Runoff Depth>4.67" Flow Length=100' Slope=0.1100 '/ Tc=5.0 min CN=79 Runoff=1.22 cfs 0.087 af
Subcatchment PRDA5ND: PRDA-5	Runoff Area=61,426 sf 22.51% Impervious Runoff Depth>4.67" Flow Length=300' Tc=5.7 min CN=79 Runoff=7.56 cfs 0.549 af
Subcatchment PRDA6ND: PRDA-6	Runoff Area=50,175 sf 19.16% Impervious Runoff Depth>4.67" Flow Length=650' Tc=5.6 min CN=79 Runoff=6.18 cfs 0.449 af
Pond BASIN A: BASIN A	Peak Elev=822.63' Storage=92,964 cf Inflow=52.94 cfs 3.990 af Outflow=6.51 cfs 3.005 af
Pond BASIN B: BASIN B	Peak Elev=824.20' Storage=41,639 cf Inflow=20.64 cfs 3.052 af Outflow=12.07 cfs 2.853 af
Link DP1: DP-1	Inflow=32.70 cfs 6.403 af Primary=32.70 cfs 6.403 af
Link DP2A: DP-2A	Inflow=6.80 cfs 0.774 af Primary=6.80 cfs 0.774 af
Link DP2B: DP-2B	Inflow=6.37 cfs 0.635 af Primary=6.37 cfs 0.635 af
Link DP3: DP-3	Inflow=6.89 cfs 3.260 af Primary=6.89 cfs 3.260 af
Link DP4: DP-4	Inflow=1.22 cfs 0.087 af Primary=1.22 cfs 0.087 af

98132 PR SC

Prepared by CIVIL 1

HydroCAD® 10.00-13 s/n 08208 © 2014 HydroCAD Software Solutions LLC

Type III 24-hr 100-Year Rainfall=7.10"

Printed 2/13/2015

Page 95

Link DP5: DP-5

Inflow=7.56 cfs 0.549 af
Primary=7.56 cfs 0.549 af

Link DP6: DP-6

Inflow=6.18 cfs 0.449 af
Primary=6.18 cfs 0.449 af

Total Runoff Area = 35.146 ac Runoff Volume = 13.341 af Average Runoff Depth = 4.56"
80.06% Pervious = 28.138 ac 19.94% Impervious = 7.008 ac

Summary for Subcatchment PRDA1D: PRDA-1

Runoff = 20.64 cfs @ 12.58 hrs, Volume= 3.052 af, Depth> 4.42"

Runoff by SCS TR-20 method, UH=SCS, Weighted-CN, Time Span= 0.00-24.00 hrs, dt= 0.05 hrs
 Type III 24-hr 100-Year Rainfall=7.10"

Area (sf)	CN	Description
36,718	98	Impervious, HSG C
1,151	98	Roofs, HSG C
18,667	98	Water Surface, HSG C
124,441	74	Pasture/grassland/range, Good, HSG C
* 115,820	75	Gravel, HSG C
64,137	70	Woods, Good, HSG C
360,934	77	Weighted Average
304,398		84.34% Pervious Area
56,536		15.66% Impervious Area

Tc (min)	Length (feet)	Slope (ft/ft)	Velocity (ft/sec)	Capacity (cfs)	Description
37.0	250	0.0320	0.11		Sheet Flow, Woods: Light underbrush n= 0.400 P2= 3.20"
5.4	600	0.0700	1.85		Shallow Concentrated Flow, Short Grass Pasture Kv= 7.0 fps
42.4	850	Total			

Subcatchment PRDA1D: PRDA-1

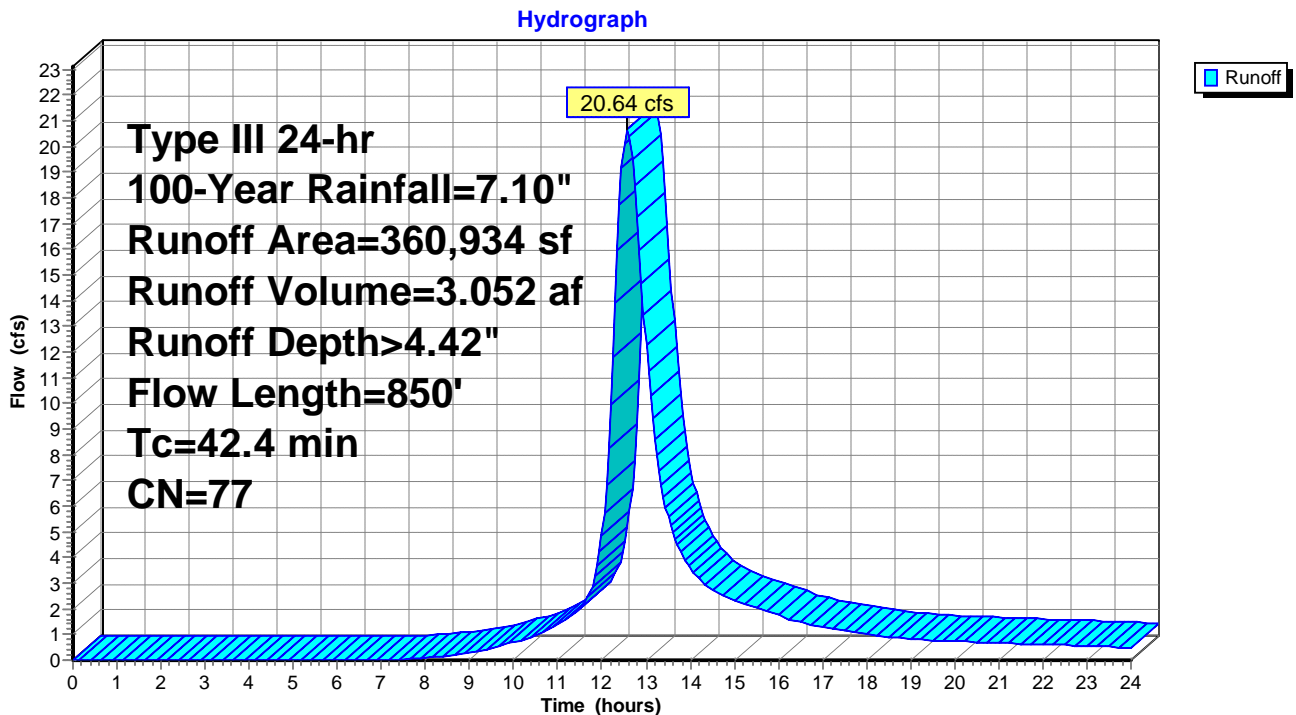

Summary for Subcatchment PRDA1ND: PRDA-1

Runoff = 23.87 cfs @ 12.59 hrs, Volume= 3.550 af, Depth> 4.31"

Runoff by SCS TR-20 method, UH=SCS, Weighted-CN, Time Span= 0.00-24.00 hrs, dt= 0.05 hrs
 Type III 24-hr 100-Year Rainfall=7.10"

Area (sf)	CN	Description
114,584	70	Woods, Good, HSG C
256,245	74	Pasture/grassland/range, Good, HSG C
59,682	98	Impervious, HSG C
430,511	76	Weighted Average
370,829		86.14% Pervious Area
59,682		13.86% Impervious Area

Tc (min)	Length (feet)	Slope (ft/ft)	Velocity (ft/sec)	Capacity (cfs)	Description
37.0	250	0.0320	0.11		Sheet Flow, Woods: Light underbrush n= 0.400 P2= 3.20"
4.9	1,000	0.0440	3.38		Shallow Concentrated Flow, Unpaved Kv= 16.1 fps
1.0	525	0.0570	8.87	53.22	Channel Flow, Area= 6.0 sf Perim= 6.0' r= 1.00' n= 0.040 Earth, cobble bottom, clean sides
42.9	1,775	Total			

Subcatchment PRDA1ND: PRDA-1

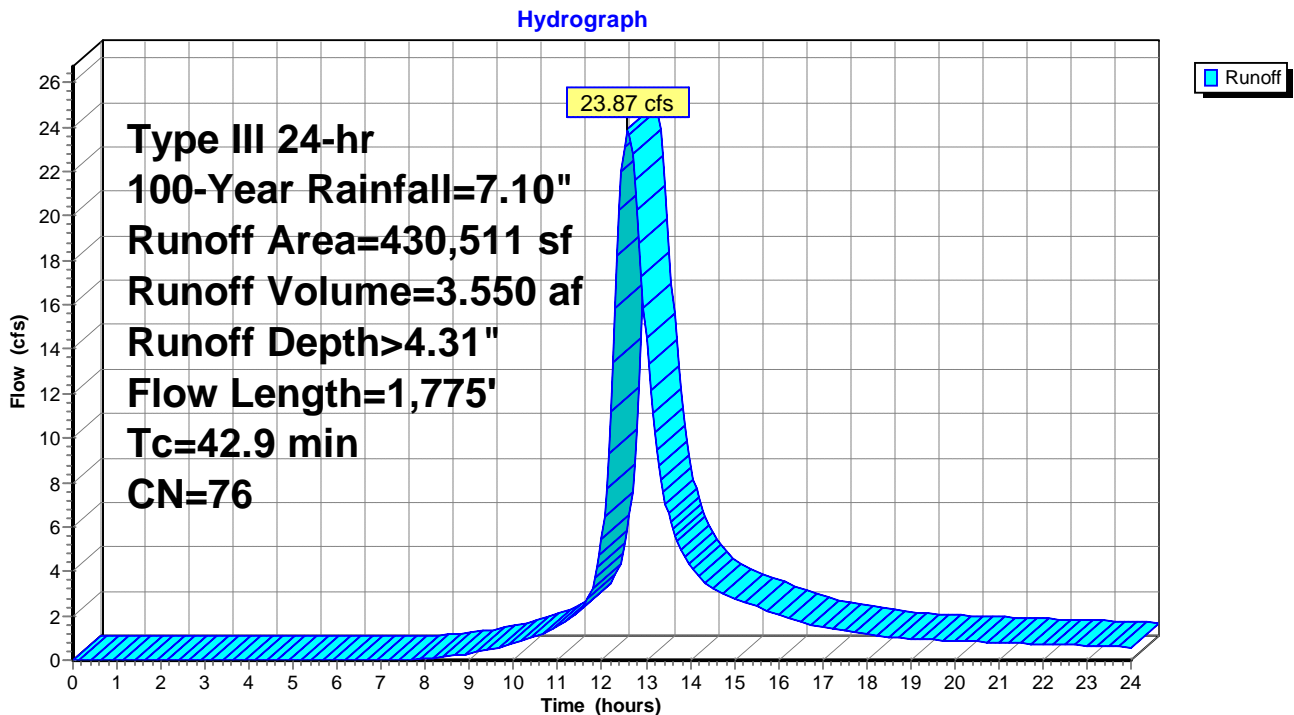

Summary for Subcatchment PRDA2AND: PRDA-2A

Runoff = 6.80 cfs @ 12.34 hrs, Volume= 0.774 af, Depth> 3.90"

Runoff by SCS TR-20 method, UH=SCS, Weighted-CN, Time Span= 0.00-24.00 hrs, dt= 0.05 hrs
 Type III 24-hr 100-Year Rainfall=7.10"

Area (sf)	CN	Description
46,490	70	Woods, Good, HSG C
57,315	74	Pasture/grassland/range, Good, HSG C
103,805	72	Weighted Average
103,805		100.00% Pervious Area

Tc (min)	Length (feet)	Slope (ft/ft)	Velocity (ft/sec)	Capacity (cfs)	Description
23.1	250	0.1040	0.18		Sheet Flow, Woods: Light underbrush n= 0.400 P2= 3.20"
1.0	150	0.2400	2.45		Shallow Concentrated Flow, Woodland Kv= 5.0 fps
24.1	400	Total			

Subcatchment PRDA2AND: PRDA-2A

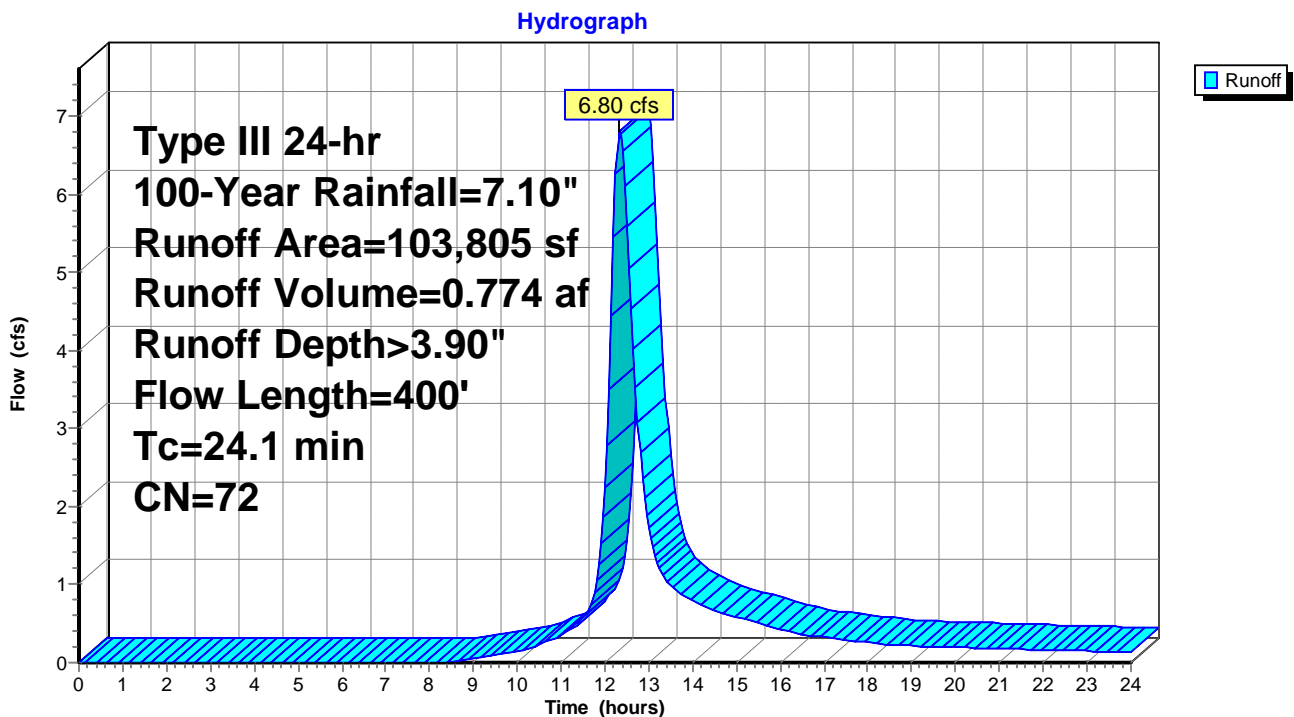

Summary for Subcatchment PRDA2BND: PRDA-2B

Runoff = 6.37 cfs @ 12.24 hrs, Volume= 0.635 af, Depth> 3.90"

Runoff by SCS TR-20 method, UH=SCS, Weighted-CN, Time Span= 0.00-24.00 hrs, dt= 0.05 hrs
 Type III 24-hr 100-Year Rainfall=7.10"

Area (sf)	CN	Description
33,200	70	Woods, Good, HSG C
51,934	74	Pasture/grassland/range, Good, HSG C
85,134	72	Weighted Average
85,134		100.00% Pervious Area

Tc (min)	Length (feet)	Slope (ft/ft)	Velocity (ft/sec)	Capacity (cfs)	Description
16.1	200	0.1650	0.21		Sheet Flow, Woods: Light underbrush n= 0.400 P2= 3.20"
1.3	100	0.0700	1.32		Shallow Concentrated Flow, Woodland Kv= 5.0 fps
17.4	300	Total			

Subcatchment PRDA2BND: PRDA-2B

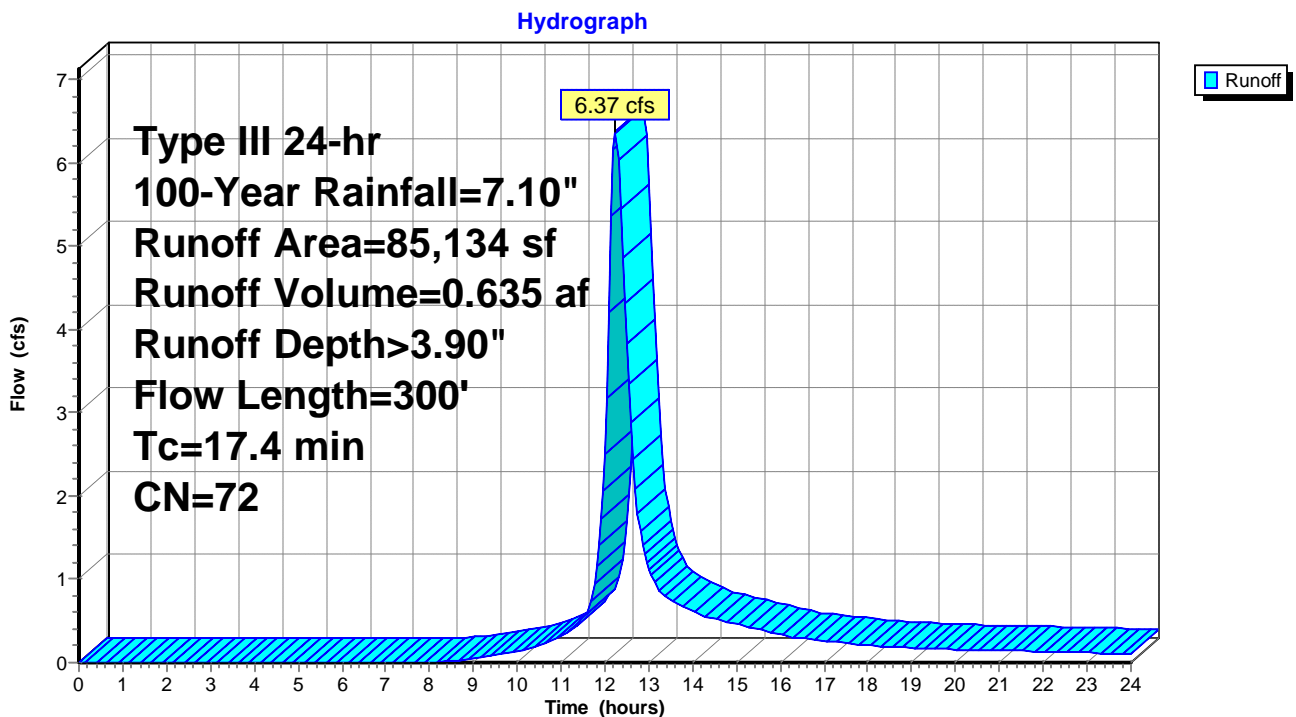

Summary for Subcatchment PRDA3D: PRDA-3

Runoff = 52.94 cfs @ 12.10 hrs, Volume= 3.990 af, Depth> 5.12"

Runoff by SCS TR-20 method, UH=SCS, Weighted-CN, Time Span= 0.00-24.00 hrs, dt= 0.05 hrs
 Type III 24-hr 100-Year Rainfall=7.10"

Area (sf)	CN	Description
69,087	98	Impervious, HSG C
36,569	98	Roofs, HSG C
41,458	98	Water Surface, HSG C
* 260,459	75	Gravel, HSG C
407,573	83	Weighted Average
260,459		63.90% Pervious Area
147,114		36.10% Impervious Area

Tc (min)	Length (feet)	Slope (ft/ft)	Velocity (ft/sec)	Capacity (cfs)	Description
3.3	250	0.0100	1.25		Sheet Flow, Smooth surfaces n= 0.011 P2= 3.20"
3.4	1,200	0.0075	5.93	7.27	Pipe Channel, 15.0" Round Area= 1.2 sf Perim= 3.9' r= 0.31' n= 0.010 PVC, smooth interior

6.7 1,450 Total

Subcatchment PRDA3D: PRDA-3

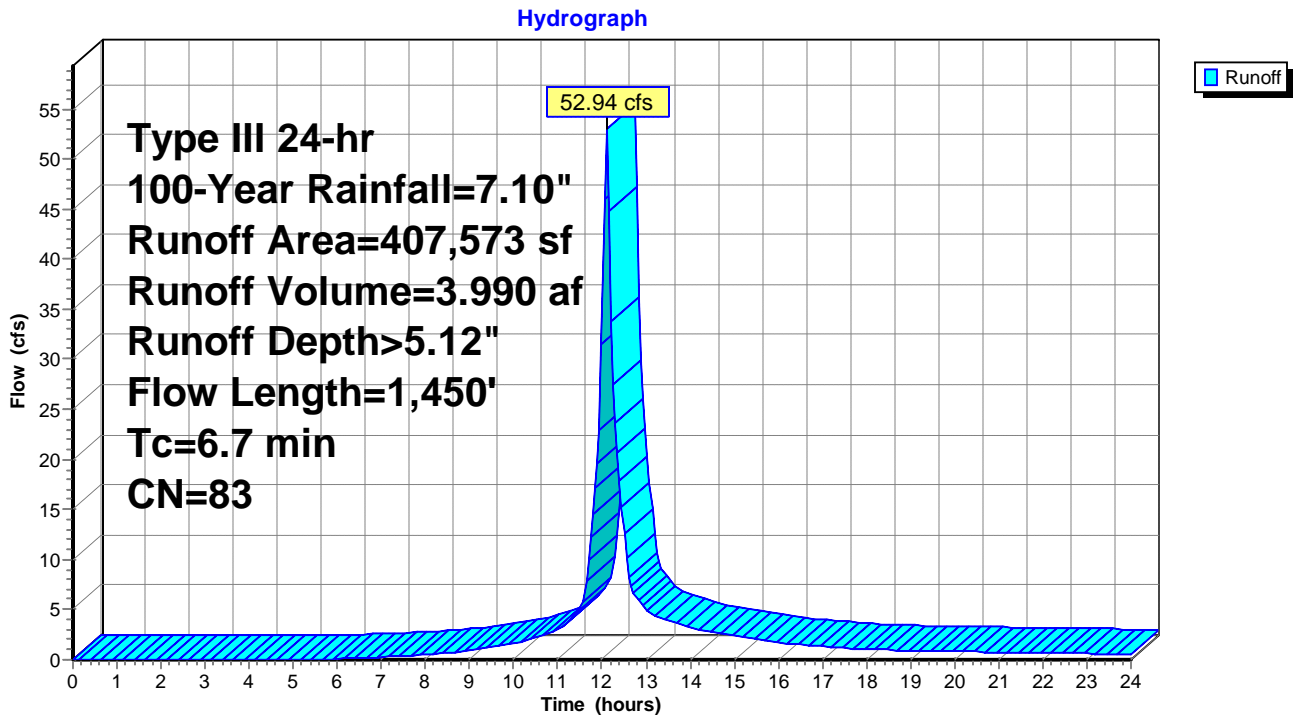

Summary for Subcatchment PRDA3ND: PRDA-3

Runoff = 3.35 cfs @ 12.07 hrs, Volume= 0.255 af, Depth> 6.15"

Runoff by SCS TR-20 method, UH=SCS, Weighted-CN, Time Span= 0.00-24.00 hrs, dt= 0.05 hrs
 Type III 24-hr 100-Year Rainfall=7.10"

Area (sf)	CN	Description
5,191	74	Pasture/grassland/range, Good, HSG C
16,497	98	Impervious, HSG C
21,688	92	Weighted Average
5,191		23.93% Pervious Area
16,497		76.07% Impervious Area

Tc (min)	Length (feet)	Slope (ft/ft)	Velocity (ft/sec)	Capacity (cfs)	Description
5.0	100	0.1100	0.34		Sheet Flow, Grass: Short n= 0.150 P2= 3.20"

Subcatchment PRDA3ND: PRDA-3

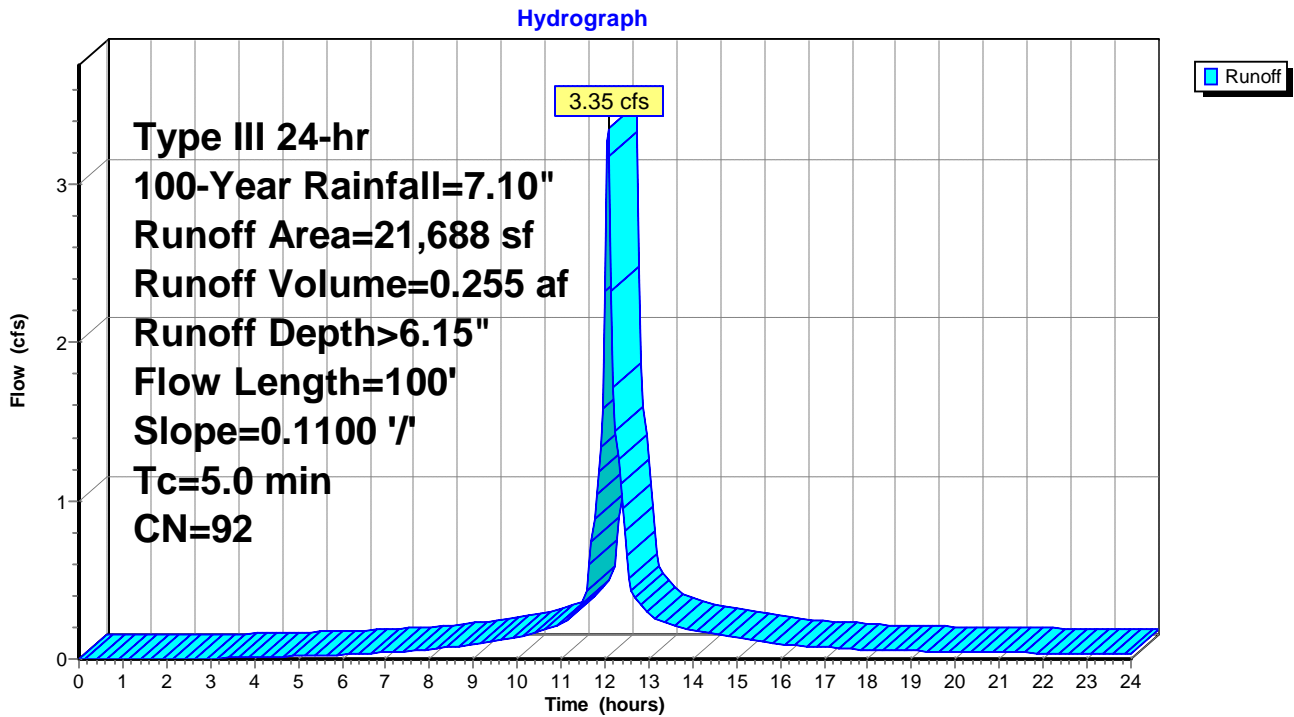

Summary for Subcatchment PRDA4ND: PRDA-4

Runoff = 1.22 cfs @ 12.07 hrs, Volume= 0.087 af, Depth> 4.67"

Runoff by SCS TR-20 method, UH=SCS, Weighted-CN, Time Span= 0.00-24.00 hrs, dt= 0.05 hrs
 Type III 24-hr 100-Year Rainfall=7.10"

Area (sf)	CN	Description
7,710	74	Pasture/grassland/range, Good, HSG C
* 1,997	98	Impervious
9,707	79	Weighted Average
7,710		79.43% Pervious Area
1,997		20.57% Impervious Area

Tc (min)	Length (feet)	Slope (ft/ft)	Velocity (ft/sec)	Capacity (cfs)	Description
5.0	100	0.1100	0.34		Sheet Flow, Grass: Short n= 0.150 P2= 3.20"

Subcatchment PRDA4ND: PRDA-4

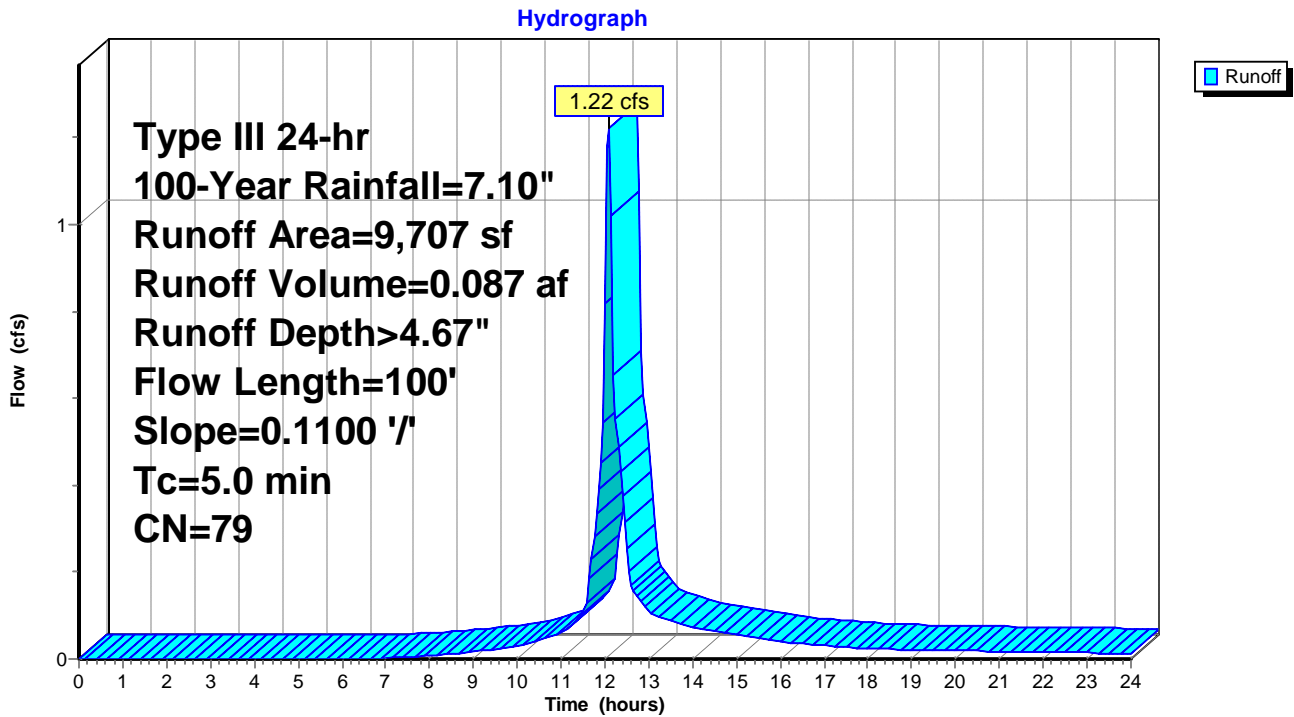

Summary for Subcatchment PRDA5ND: PRDA-5

Runoff = 7.56 cfs @ 12.09 hrs, Volume= 0.549 af, Depth> 4.67"

Runoff by SCS TR-20 method, UH=SCS, Weighted-CN, Time Span= 0.00-24.00 hrs, dt= 0.05 hrs
 Type III 24-hr 100-Year Rainfall=7.10"

Area (sf)	CN	Description
13,824	98	Impervious, HSG C
47,602	74	Pasture/grassland/range, Good, HSG C
61,426	79	Weighted Average
47,602		77.49% Pervious Area
13,824		22.51% Impervious Area

Tc (min)	Length (feet)	Slope (ft/ft)	Velocity (ft/sec)	Capacity (cfs)	Description
5.5	200	0.3333	0.60		Sheet Flow, Grass: Short n= 0.150 P2= 3.20"
0.2	100	0.0100	6.84	8.40	Pipe Channel, 15.0" Round Area= 1.2 sf Perim= 3.9' r= 0.31' n= 0.010 PVC, smooth interior
5.7	300	Total			

Subcatchment PRDA5ND: PRDA-5

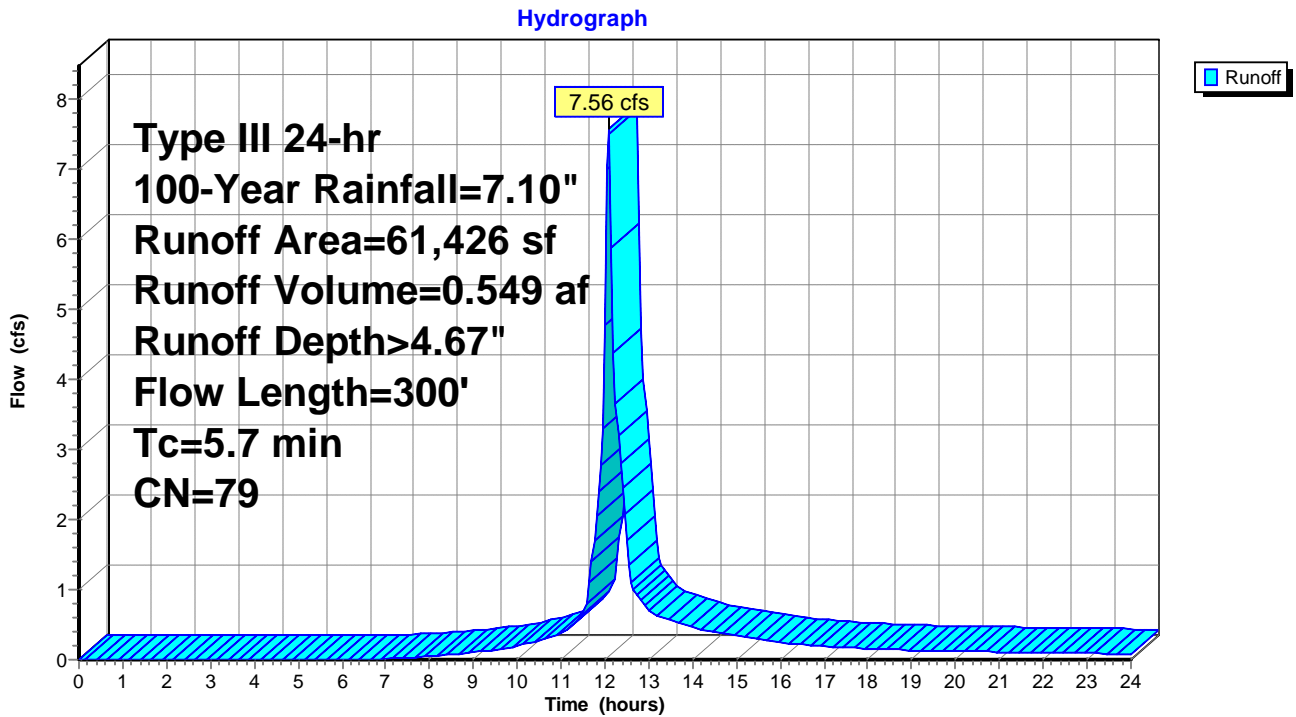

Summary for Subcatchment PRDA6ND: PRDA-6

Runoff = 6.18 cfs @ 12.09 hrs, Volume= 0.449 af, Depth> 4.67"

Runoff by SCS TR-20 method, UH=SCS, Weighted-CN, Time Span= 0.00-24.00 hrs, dt= 0.05 hrs
 Type III 24-hr 100-Year Rainfall=7.10"

Area (sf)	CN	Description
40,563	74	Pasture/grassland/range, Good, HSG C
9,612	98	Impervious, HSG C
50,175	79	Weighted Average
40,563		80.84% Pervious Area
9,612		19.16% Impervious Area

Tc (min)	Length (feet)	Slope (ft/ft)	Velocity (ft/sec)	Capacity (cfs)	Description
4.4	150	0.3333	0.57		Sheet Flow, Grass: Short n= 0.150 P2= 3.20"
1.2	500	0.2050	6.79		Shallow Concentrated Flow, Grassed Waterway Kv= 15.0 fps
5.6	650	Total			

Subcatchment PRDA6ND: PRDA-6

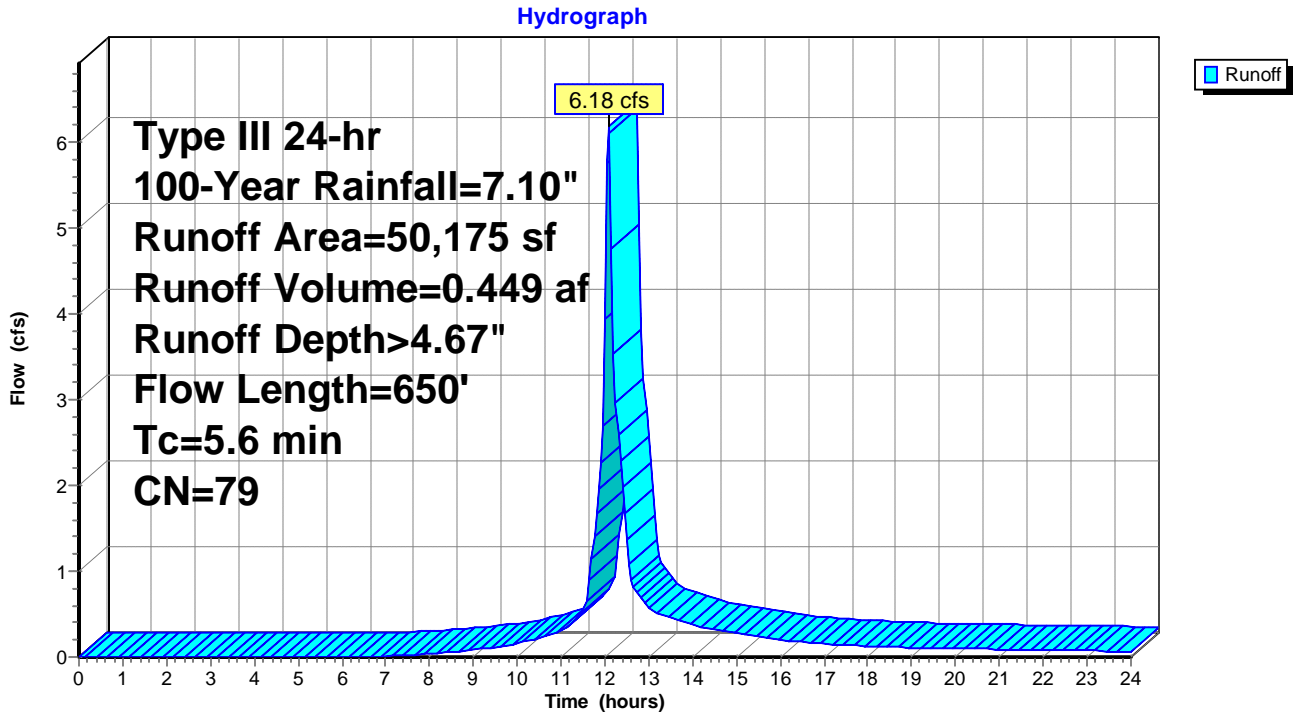

Summary for Pond BASIN A: BASIN A

Inflow Area = 9.357 ac, 36.10% Impervious, Inflow Depth > 5.12" for 100-Year event
 Inflow = 52.94 cfs @ 12.10 hrs, Volume= 3.990 af
 Outflow = 6.51 cfs @ 12.74 hrs, Volume= 3.005 af, Atten= 88%, Lag= 38.6 min
 Primary = 6.51 cfs @ 12.74 hrs, Volume= 3.005 af

Routing by Stor-Ind method, Time Span= 0.00-24.00 hrs, dt= 0.05 hrs
 Peak Elev= 822.63' @ 12.74 hrs Surf.Area= 40,062 sf Storage= 92,964 cf

Plug-Flow detention time= 265.9 min calculated for 2.999 af (75% of inflow)
 Center-of-Mass det. time= 182.4 min (982.4 - 800.0)

Volume	Invert	Avail.Storage	Storage Description
#1	820.00'	151,470 cf	Basin A (Irregular) Listed below (Recalc)

Elevation (feet)	Surf.Area (sq-ft)	Perim. (feet)	Inc.Store (cubic-feet)	Cum.Store (cubic-feet)	Wet.Area (sq-ft)
820.00	30,856	1,150.0	0	0	30,856
822.00	37,867	1,187.0	68,603	68,603	38,123
824.00	45,105	1,225.0	82,867	151,470	45,805

Device	Routing	Invert	Outlet Devices
#1	Primary	820.00'	15.0" Round Culvert L= 250.0' Ke= 0.500 Inlet / Outlet Invert= 820.00' / 786.00' S= 0.1360 ' / Cc= 0.900 n= 0.010 PVC, smooth interior, Flow Area= 1.23 sf
#2	Device 1	820.00'	8.0" Vert. Orifice/Grate C= 0.600
#3	Device 1	822.00'	15.0" W x 12.0" H Vert. Orifice/Grate X 2.00 C= 0.600

Primary OutFlow Max=6.51 cfs @ 12.74 hrs HW=822.63' (Free Discharge)

- 1=Culvert (Passes 6.51 cfs of 8.36 cfs potential flow)
- 2=Orifice/Grate (Orifice Controls 2.54 cfs @ 7.29 fps)
- 3=Orifice/Grate (Orifice Controls 3.97 cfs @ 2.54 fps)

Pond BASIN A: BASIN A

Hydrograph

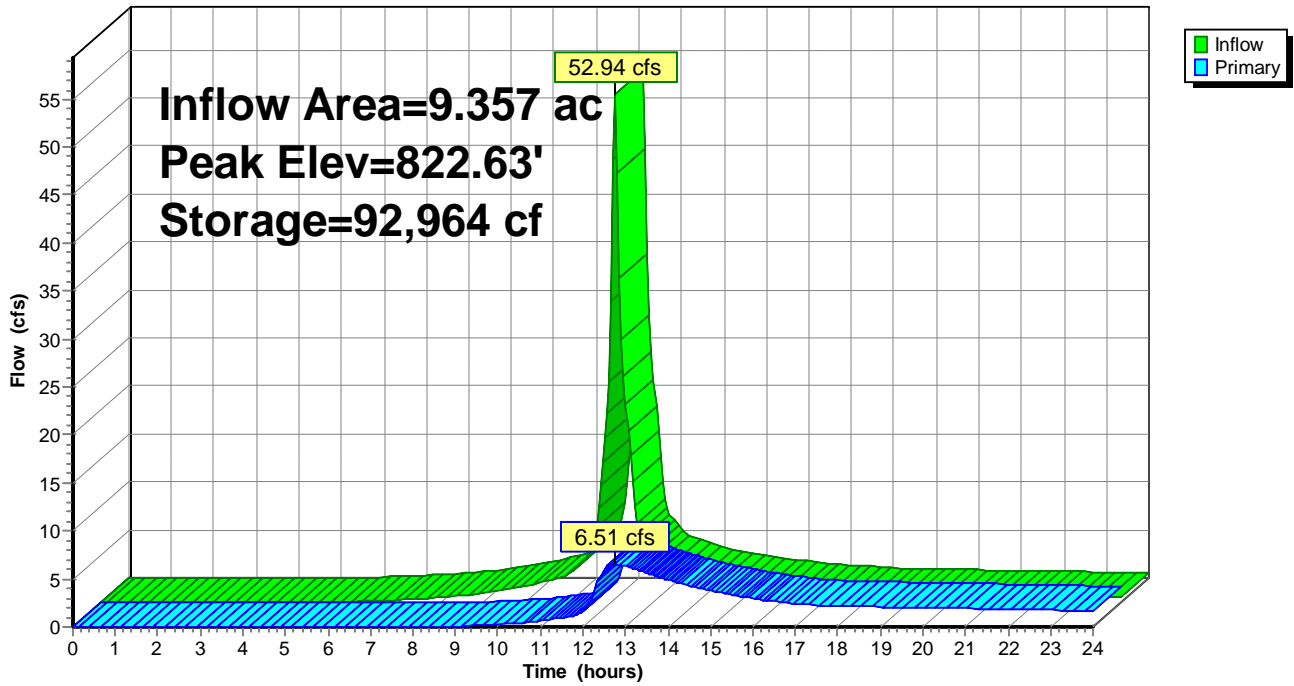

Summary for Pond BASIN B: BASIN B

Inflow Area = 8.286 ac, 15.66% Impervious, Inflow Depth > 4.42" for 100-Year event
 Inflow = 20.64 cfs @ 12.58 hrs, Volume= 3.052 af
 Outflow = 12.07 cfs @ 13.01 hrs, Volume= 2.853 af, Atten= 41%, Lag= 25.9 min
 Primary = 12.07 cfs @ 13.01 hrs, Volume= 2.853 af

Routing by Stor-Ind method, Time Span= 0.00-24.00 hrs, dt= 0.05 hrs
 Peak Elev= 824.20' @ 13.01 hrs Surf.Area= 16,730 sf Storage= 41,639 cf

Plug-Flow detention time= 96.0 min calculated for 2.853 af (93% of inflow)
 Center-of-Mass det. time= 63.2 min (906.4 - 843.3)

Volume	Invert	Avail.Storage	Storage Description		
#1	821.00'	122,878 cf	Basin B (Irregular) Listed below (Recalc)		
Elevation (feet)	Surf.Area (sq-ft)	Perim. (feet)	Inc.Store (cubic-feet)	Cum.Store (cubic-feet)	Wet.Area (sq-ft)
821.00	9,468	729.0	0	0	9,468
822.00	11,682	748.0	10,556	10,556	11,820
824.00	16,283	786.0	27,838	38,394	16,706
826.00	21,113	824.1	37,292	75,685	21,846
828.00	26,170	850.0	47,193	122,878	25,681

Device	Routing	Invert	Outlet Devices	
#1	Primary	821.00'	18.0" Round Culvert L= 100.0' Ke= 0.500 Inlet / Outlet Invert= 821.00' / 797.00' S= 0.2400 '/' Cc= 0.900 n= 0.010 PVC, smooth interior, Flow Area= 1.77 sf	
#2	Device 1	821.00'	6.0" Vert. Orifice/Grate C= 0.600	
#3	Device 1	822.00'	12.0" W x 30.0" H Vert. Orifice/Grate C= 0.600	
#4	Primary	825.00'	24.0" Vert. Orifice/Grate C= 0.600	

Primary OutFlow Max=12.07 cfs @ 13.01 hrs HW=824.20' (Free Discharge)

- 1=Culvert (Passes 12.07 cfs of 13.31 cfs potential flow)
- 2=Orifice/Grate (Orifice Controls 1.62 cfs @ 8.26 fps)
- 3=Orifice/Grate (Orifice Controls 10.44 cfs @ 4.76 fps)
- 4=Orifice/Grate (Controls 0.00 cfs)

Pond BASIN B: BASIN B

Hydrograph

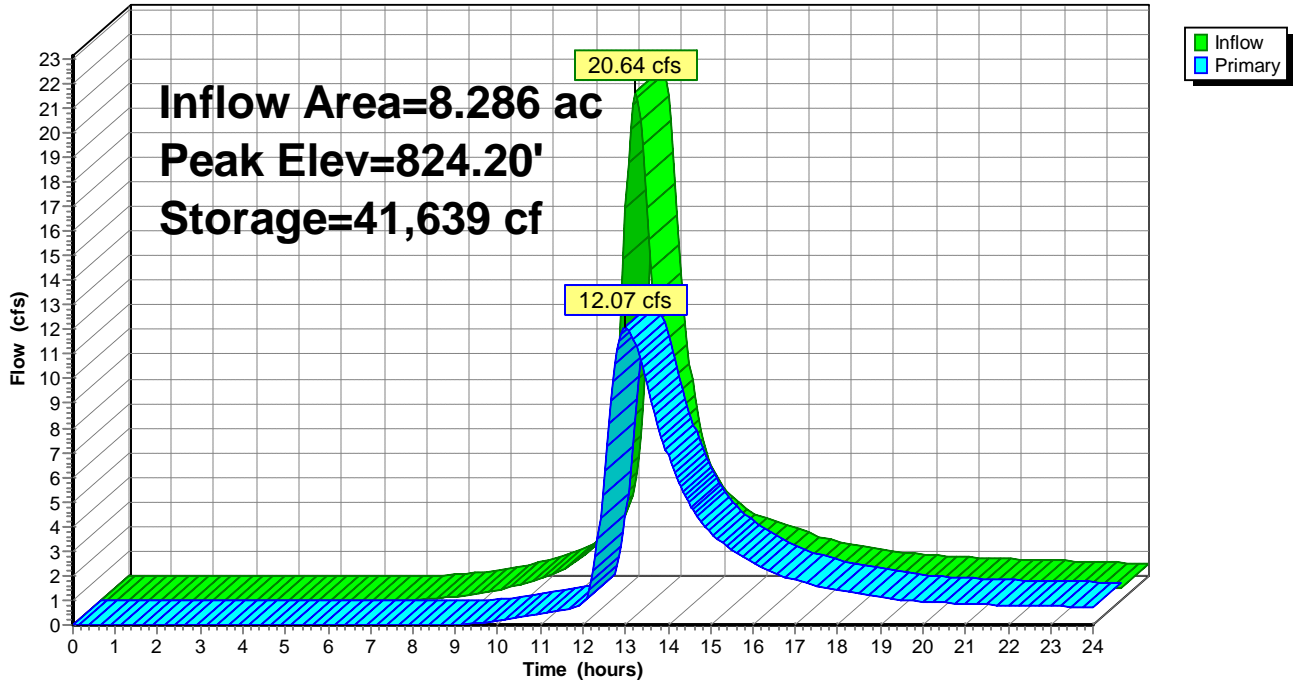

Summary for Link DP1: DP-1

Inflow Area = 18.169 ac, 14.68% Impervious, Inflow Depth > 4.23" for 100-Year event
Inflow = 32.70 cfs @ 12.68 hrs, Volume= 6.403 af
Primary = 32.70 cfs @ 12.68 hrs, Volume= 6.403 af, Atten= 0%, Lag= 0.0 min

Primary outflow = Inflow, Time Span= 0.00-24.00 hrs, dt= 0.05 hrs

Link DP1: DP-1

Hydrograph

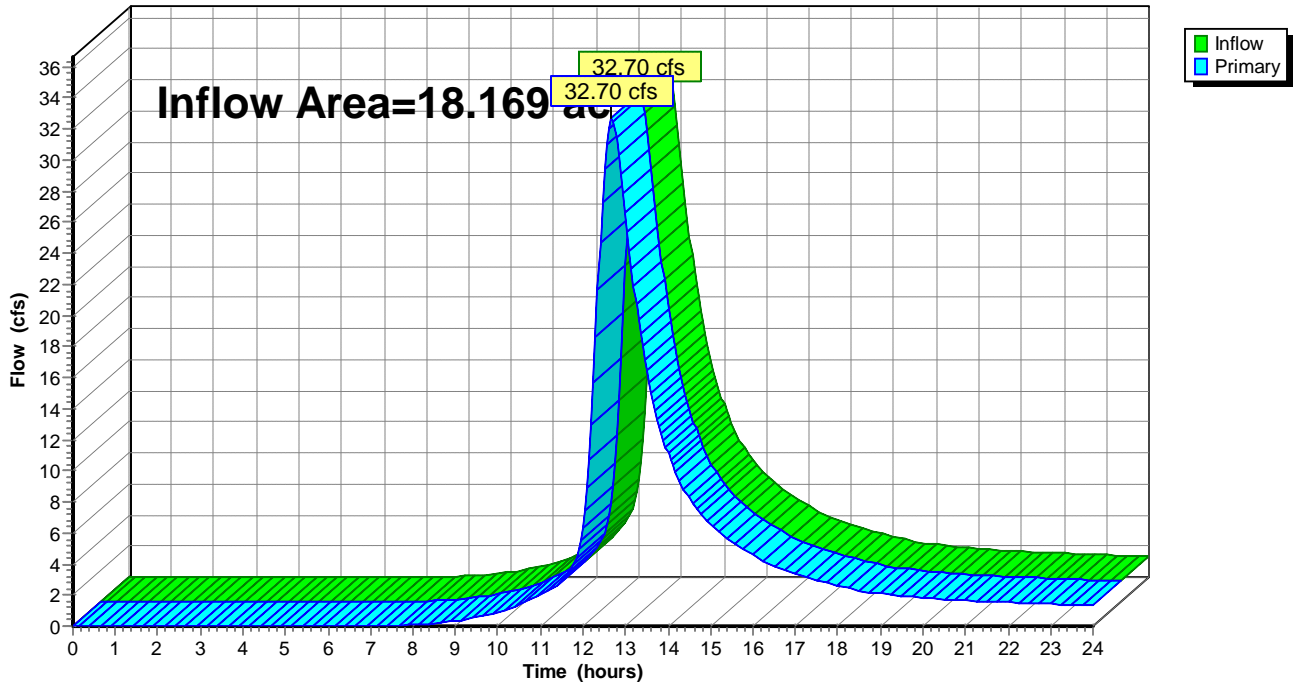

Summary for Link DP2A: DP-2A

Inflow Area = 2.383 ac, 0.00% Impervious, Inflow Depth > 3.90" for 100-Year event
Inflow = 6.80 cfs @ 12.34 hrs, Volume= 0.774 af
Primary = 6.80 cfs @ 12.34 hrs, Volume= 0.774 af, Atten= 0%, Lag= 0.0 min

Primary outflow = Inflow, Time Span= 0.00-24.00 hrs, dt= 0.05 hrs

Link DP2A: DP-2A

Hydrograph

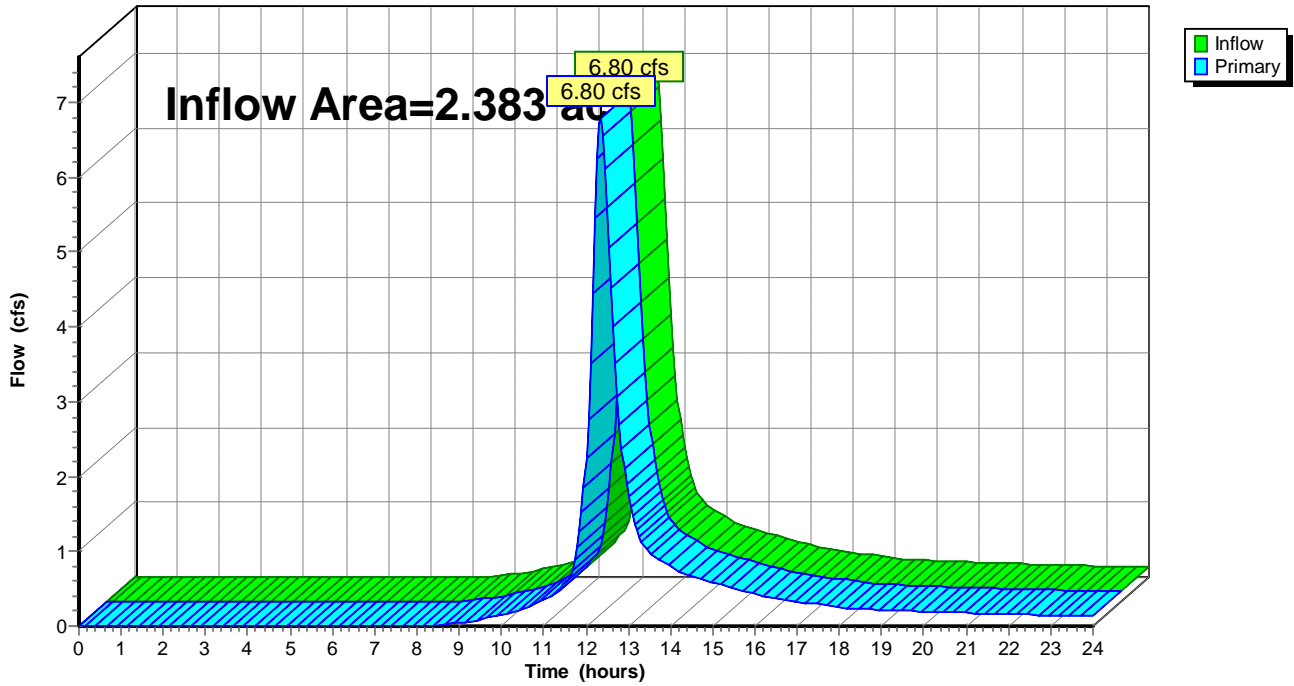

Summary for Link DP2B: DP-2B

Inflow Area = 1.954 ac, 0.00% Impervious, Inflow Depth > 3.90" for 100-Year event
Inflow = 6.37 cfs @ 12.24 hrs, Volume= 0.635 af
Primary = 6.37 cfs @ 12.24 hrs, Volume= 0.635 af, Atten= 0%, Lag= 0.0 min

Primary outflow = Inflow, Time Span= 0.00-24.00 hrs, dt= 0.05 hrs

Link DP2B: DP-2B

Hydrograph

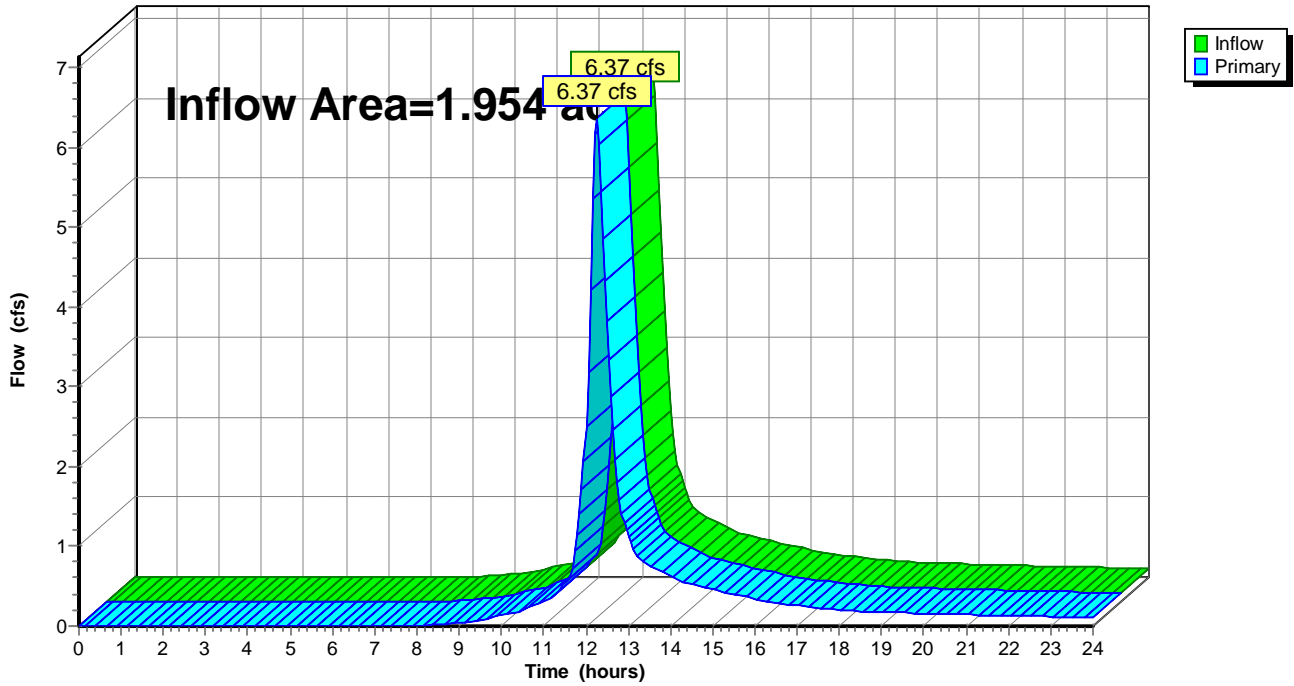

Summary for Link DP3: DP-3

Inflow Area = 9.854 ac, 38.11% Impervious, Inflow Depth > 3.97" for 100-Year event
Inflow = 6.89 cfs @ 12.69 hrs, Volume= 3.260 af
Primary = 6.89 cfs @ 12.69 hrs, Volume= 3.260 af, Atten= 0%, Lag= 0.0 min

Primary outflow = Inflow, Time Span= 0.00-24.00 hrs, dt= 0.05 hrs

Link DP3: DP-3

Hydrograph

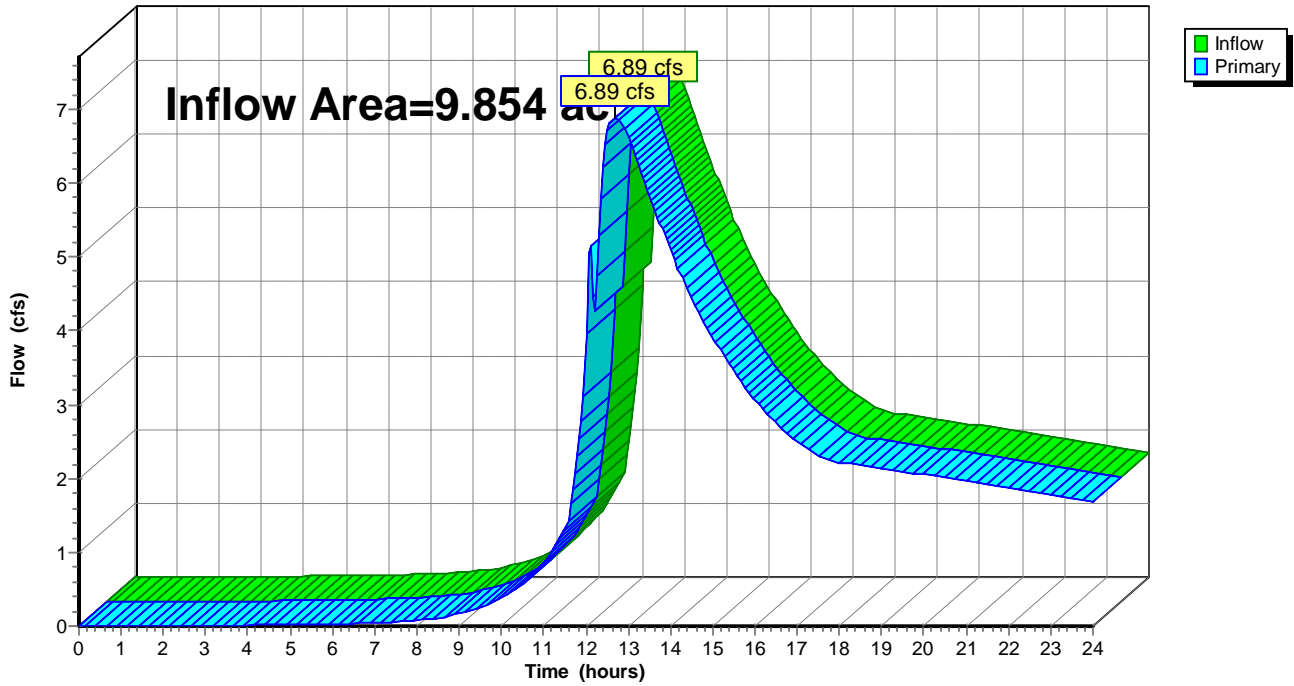

Summary for Link DP4: DP-4

Inflow Area = 0.223 ac, 20.57% Impervious, Inflow Depth > 4.67" for 100-Year event
Inflow = 1.22 cfs @ 12.07 hrs, Volume= 0.087 af
Primary = 1.22 cfs @ 12.07 hrs, Volume= 0.087 af, Atten= 0%, Lag= 0.0 min

Primary outflow = Inflow, Time Span= 0.00-24.00 hrs, dt= 0.05 hrs

Link DP4: DP-4

Hydrograph

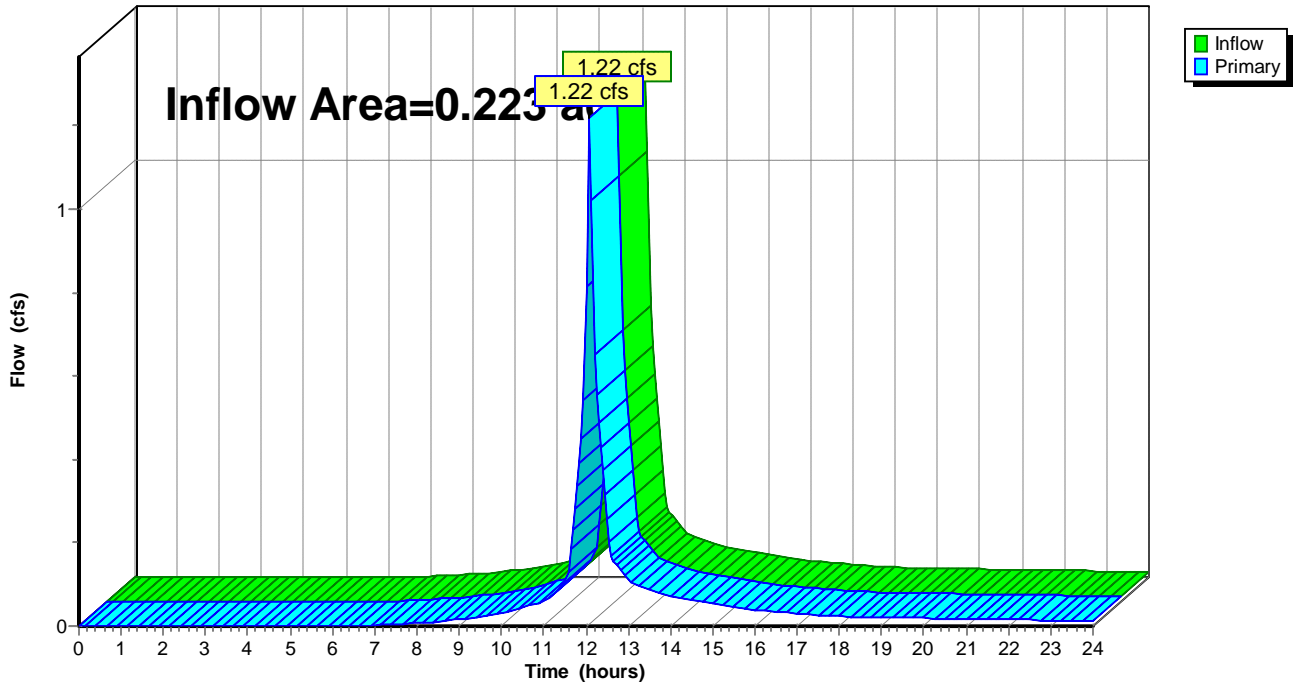

Summary for Link DP5: DP-5

Inflow Area = 1.410 ac, 22.51% Impervious, Inflow Depth > 4.67" for 100-Year event
Inflow = 7.56 cfs @ 12.09 hrs, Volume= 0.549 af
Primary = 7.56 cfs @ 12.09 hrs, Volume= 0.549 af, Atten= 0%, Lag= 0.0 min

Primary outflow = Inflow, Time Span= 0.00-24.00 hrs, dt= 0.05 hrs

Link DP5: DP-5

Hydrograph

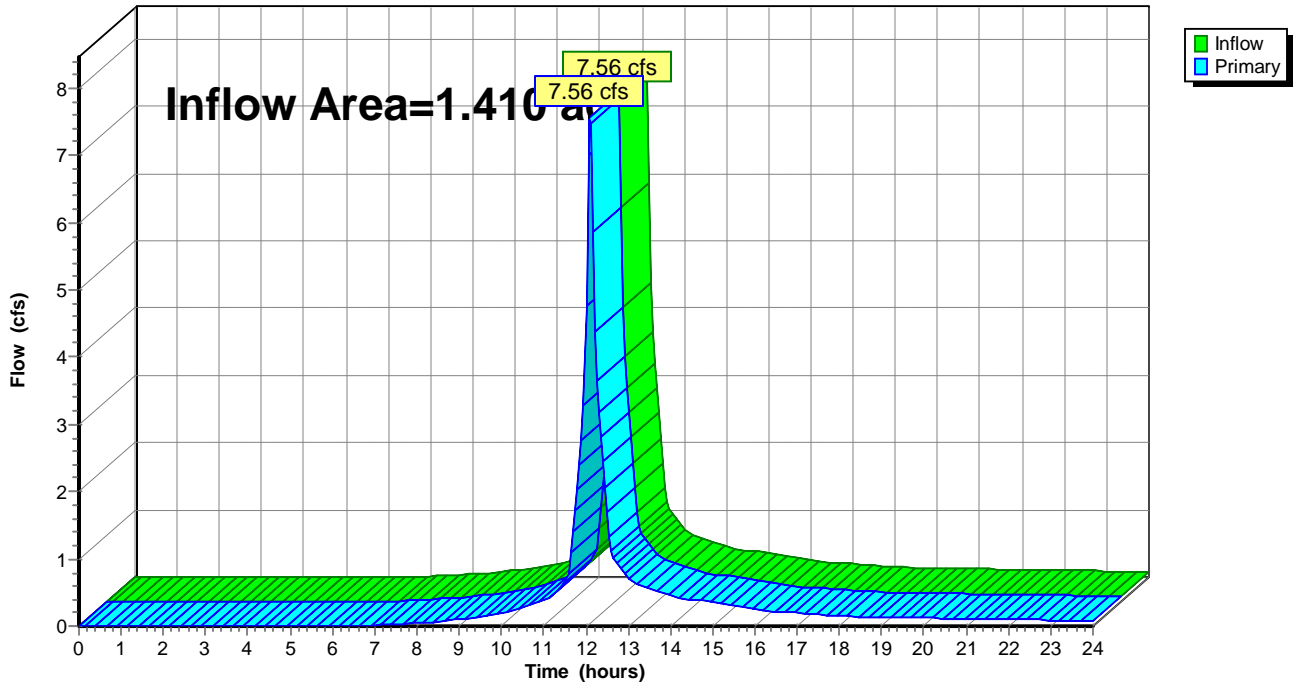

Summary for Link DP6: DP-6

Inflow Area = 1.152 ac, 19.16% Impervious, Inflow Depth > 4.67" for 100-Year event
Inflow = 6.18 cfs @ 12.09 hrs, Volume= 0.449 af
Primary = 6.18 cfs @ 12.09 hrs, Volume= 0.449 af, Atten= 0%, Lag= 0.0 min

Primary outflow = Inflow, Time Span= 0.00-24.00 hrs, dt= 0.05 hrs

Link DP6: DP-6

Hydrograph

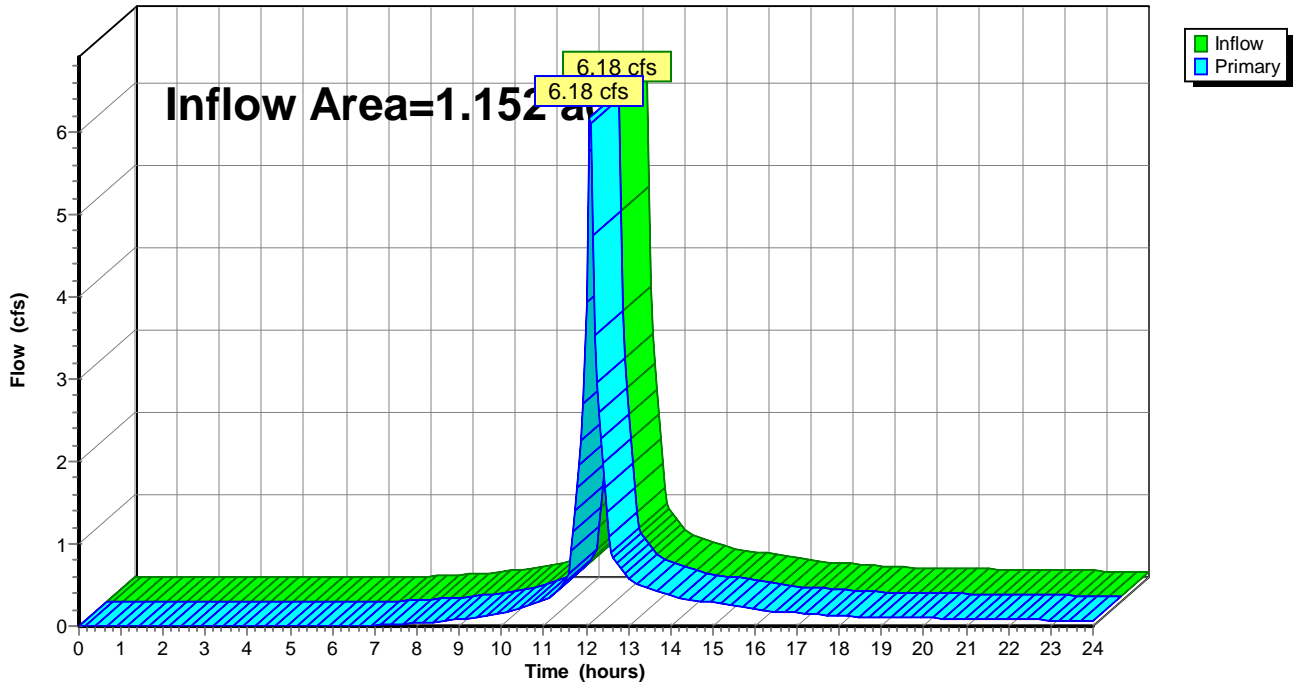

Appendix D – Rational Method Pipe Sizing

STORM SEWER SYSTEM DESIGN
 CPV Towantic Energy Center
 Oxford, CT
 25 Year Design Storm

Drainage Area	Impervious (0.9)	Grass or Crushed Stone (0.3)	Wooded (0.2)	Total Area (Ac.)	Average C	Sum of AxC	Tc
STDA A1	0.078	0.000	0.000	0.078	0.90	0.07	5.00
STDA A2	0.066	0.240	0.000	0.306	0.43	0.13	5.00
STDA A3	0.101	0.163	0.000	0.264	0.53	0.14	5.00
STDA A4	0.108	0.282	0.000	0.391	0.47	0.18	5.00
STDA A5	0.085	0.000	0.000	0.085	0.90	0.08	5.00
STDA A6	0.039	0.000	0.000	0.039	0.90	0.03	5.00
STDA A7	0.151	0.014	0.000	0.166	0.85	0.14	5.00
STDA A8	0.096	0.002	0.000	0.098	0.89	0.09	5.00
STDA A9	0.484	0.063	0.000	0.547	0.83	0.45	5.00
STDA A10	0.068	0.053	0.000	0.121	0.64	0.08	5.00
STDA A11	0.134	0.126	0.000	0.261	0.61	0.16	5.00
STDA A12	0.041	0.017	0.000	0.059	0.72	0.04	5.00
STDA A13	0.049	0.302	0.000	0.350	0.38	0.13	5.00
STDA A14	0.108	0.237	0.000	0.345	0.49	0.17	5.00
STDA A15	0.260	0.236	0.000	0.495	0.61	0.30	5.00
STDA A16	0.040	0.214	0.000	0.254	0.39	0.10	5.00
STDA A17	0.011	0.540	0.000	0.552	0.31	0.17	5.00
STDA A18	0.040	0.249	0.000	0.290	0.38	0.11	5.00
STDA A19	0.055	0.213	0.000	0.268	0.42	0.11	5.00
STDA A20	0.041	0.088	0.000	0.129	0.49	0.06	5.00
STDA A21	0.198	0.024	0.000	0.222	0.83	0.19	5.00
STDA B1	0.074	0.192	0.000	0.266	0.47	0.12	5.00
STDA B2	0.096	0.080	0.000	0.175	0.63	0.11	5.00
STDA B3	0.112	0.304	0.000	0.416	0.46	0.19	5.00
STDA B4	0.073	0.302	0.000	0.375	0.42	0.16	5.00
STDA B5	0.083	0.196	0.000	0.279	0.48	0.13	5.00
STDA B6	0.038	0.295	0.000	0.333	0.37	0.12	5.00
STDA B7	0.132	0.226	0.000	0.358	0.52	0.19	5.00
STDA B8	0.102	0.070	0.000	0.172	0.66	0.11	5.00
STDA B9	0.127	0.148	0.000	0.275	0.58	0.16	5.00
STDA B10	0.035	0.565	0.000	0.600	0.34	0.20	5.00
STDA B11	0.000	0.496	0.000	0.496	0.30	0.15	5.00
STDA B12	0.000	0.289	0.000	0.289	0.30	0.09	5.00
STDA C1	0.120	0.347	0.000	0.467	0.45	0.21	5.00
STDA C2	0.123	0.013	0.000	0.136	0.84	0.11	5.00
STDA D	0.059	0.303	0.000	0.362	0.40	0.14	5.00
STDA E1	0.081	0.516	0.000	0.597	0.38	0.23	5.00
STDA E2	0.091	0.555	0.000	0.646	0.38	0.25	5.00

STORM SEWER SYSTEM DESIGN
 CPV Towantic Energy Center
 Oxford, CT
 25 Year Design Storm

LINE	DRAINAGE	SEGMENT	TIME TO	TIME IN	ACCUM.	SUM OF	ACCUM.	RAINFALL	SYSTEM	PIPE	PIPE (ft)	SLOPE	Vfull	Qfull	N'	CAPACITY	HW/D
SEGMENT	AREA	TYPE	INLET	PIPE	TIME	AxC	AxC	I	Q (cfs)	SIZE (in)	LENGTH	(ft/ft)	(fps)	(cfs)		CHECK	
CB A1 - CB A2	STDA A1	I	5.00	0.14	5.00	0.07	0.07	6.70	0.47	15	46	0.0075	5.39	6.61	0.0110	WITHIN CAPACITY	<0.5
CB A2 - CB A3	STDA A2	C	5.00	0.24	5.14	0.13	0.20	6.70	1.35	15	77	0.0075	5.39	6.61	0.0110	WITHIN CAPACITY	0.5
CB A3 - CB A4	STDA A3	C	5.00	0.31	5.38	0.14	0.34	6.70	2.29	15	101	0.0075	5.39	6.61	0.0110	WITHIN CAPACITY	0.7
CB A4 - CB A5	STDA A4	C	5.00	0.11	5.69	0.18	0.52	6.70	3.51	15	34	0.0075	5.39	6.61	0.0110	WITHIN CAPACITY	0.9
CB A5 - CB A6	STDA A5	C	5.00	0.70	5.80	0.08	0.60	6.70	4.02	15	226	0.0075	5.39	6.61	0.0110	WITHIN CAPACITY	1
CB A6 - CB A7	STDA A6	C	5.00	0.05	6.50	0.03	0.63	6.70	4.25	15	17	0.0075	5.39	6.61	0.0110	WITHIN CAPACITY	1.05
CB A7 - BASIN A	STDA A7	C	5.00	0.22	6.55	0.14	0.78	6.70	5.19	15	115	0.0195	8.69	10.66	0.0110	WITHIN CAPACITY	1.1
CB A8 - CB A9	STDA A8	I	5.00	0.10	5.00	0.09	0.09	6.70	0.58	15	32	0.0075	5.39	6.61	0.0110	WITHIN CAPACITY	<0.5
CB A9 - CB A11	STDA A9	C	5.00	0.69	5.10	0.45	0.54	6.70	3.63	15	224	0.0075	5.39	6.61	0.0110	WITHIN CAPACITY	0.9
CB A10 - CB A11	STDA A10	I	5.00	0.02	5.00	0.08	0.08	6.70	0.52	15	17	0.0700	16.46	20.20	0.0110	WITHIN CAPACITY	<0.5
CB A11 - DMH A1	STDA A11	C	5.00	0.19	5.79	0.16	0.78	6.70	5.21	15	62	0.0075	5.39	6.61	0.0110	WITHIN CAPACITY	1.25
DMH A1 - CB A14	N/A	C	5.00	0.29	5.98	0.00	0.78	6.70	5.21	15	93	0.0075	5.39	6.61	0.0110	WITHIN CAPACITY	1.25
CB A12 - CB A14	STDA A12	I	5.00	0.05	5.00	0.04	0.04	6.70	0.28	15	17	0.0100	6.22	7.63	0.0110	WITHIN CAPACITY	<0.5
CB A13 - CB A14	STDA A13	I	5.00	0.25	5.00	0.13	0.13	6.70	0.90	15	140	0.0231	9.46	11.60	0.0110	WITHIN CAPACITY	<0.5
CB A14 - DMH A2	STDA A14	C	5.00	0.28	6.27	0.17	1.12	6.70	7.52	18	102	0.0075	6.08	10.75	0.0110	WITHIN CAPACITY	1.15
CB A15 - CB 16	STDA A15	I	5.00	0.39	5.00	0.30	0.30	6.70	2.04	15	167	0.0133	7.17	8.80	0.0110	WITHIN CAPACITY	0.65
CB A16 - DMH A2	STDA A16	C	5.00	0.28	5.39	0.10	0.40	6.70	2.71	15	120	0.0133	7.17	8.80	0.0110	WITHIN CAPACITY	0.75
DMH A2 - CB A20	N/A	C	5.00	0.16	6.55	0.00	1.53	6.70	10.23	24	72	0.0075	7.37	23.15	0.0110	WITHIN CAPACITY	0.85
CB A17 - CB A18	STDA A17	I	5.00	0.56	5.00	0.17	0.17	6.70	1.15	15	232	0.0125	6.96	8.54	0.0110	WITHIN CAPACITY	<0.5
CB A18 - CB A19	STDA A18	C	5.00	0.05	5.56	0.11	0.28	6.70	1.90	15	22	0.0125	6.96	8.54	0.0110	WITHIN CAPACITY	0.6
CB A19 - DMH A3	STDA A19	C	5.00	0.13	5.61	0.11	0.40	6.70	2.66	15	54	0.0125	6.96	8.54	0.0110	WITHIN CAPACITY	0.75
DMH A3 - CB A20	N/A	C	5.00	0.15	5.74	0.00	0.40	6.70	2.66	15	69	0.0148	7.57	9.29	0.0110	WITHIN CAPACITY	0.75
CB A20 - CB A21	STDA A20	C	5.00	0.12	6.71	0.06	1.99	6.70	13.31	24	54	0.0075	7.37	23.15	0.0110	WITHIN CAPACITY	1.05
CB A21 - BASIN A	STDA A21	C	5.00	0.31	6.84	0.19	2.17	6.70	14.55	24	145	0.0083	7.75	24.36	0.0110	WITHIN CAPACITY	1.1
CB B1 - CB B2	STDA B1	I	5.00	0.11	5.00	0.12	0.12	6.70	0.83	15	34	0.0075	5.39	6.61	0.0110	WITHIN CAPACITY	<0.5
CB B2 - DMH B1	STDA B2	C	5.00	0.24	5.11	0.11	0.23	6.70	1.57	15	76	0.0075	5.39	6.61	0.0110	WITHIN CAPACITY	0.55
DMH B1 - CB B3	N/A	C	5.00	0.35	5.34	0.00	0.23	6.70	1.57	15	114	0.0075	5.39	6.61	0.0110	WITHIN CAPACITY	0.55
CB B3 - CB B4	STDA B3	C	5.00	0.42	5.69	0.19	0.43	6.70	2.86	15	137	0.0075	5.39	6.61	0.0110	WITHIN CAPACITY	0.8
CB B4 - DMH B2	STDA B4	C	5.00	0.17	6.12	0.16	0.58	6.70	3.90	15	56	0.0075	5.39	6.61	0.0110	WITHIN CAPACITY	1
DMH B2 - CB B12	N/A	C	5.00	0.20	6.29	0.00	0.58	6.70	3.90	15	95	0.0155	7.75	9.50	0.0110	WITHIN CAPACITY	1
CB B5 - CB B6	STDA B5	I	5.00	0.05	5.00	0.13	0.13	6.70	0.89	15	17	0.0075	5.39	6.61	0.0110	WITHIN CAPACITY	<0.5
CB B6 - DMH B3	STDA B6	C	5.00	0.37	5.05	0.12	0.26	6.70	1.72	15	149	0.0115	6.67	8.19	0.0110	WITHIN CAPACITY	0.6
CB B7 - CB B8	STDA B7	I	5.00	0.06	5.00	0.19	0.19	6.70	1.25	15	20	0.0075	5.39	6.61	0.0110	WITHIN CAPACITY	<0.5
CB B8 - DMH B3	STDA B8	C	5.00	0.41	5.06	0.11	0.30	6.70	2.00	15	132	0.0075	5.39	6.61	0.0110	WITHIN CAPACITY	0.65
CB B9 - DMH B3	STDA B9	I	5.00	0.02	5.00	0.16	0.16	6.70	1.06	15	24	0.0683	16.26	19.95	0.0110	WITHIN CAPACITY	<0.5
DMH B3 - CB B10	N/A	C	5.00	0.24	5.42	0.00	0.71	6.70	4.78	15	76	0.0075	5.39	6.61	0.0110	WITHIN CAPACITY	1.15
CB B10 - CB B11	STDA B10	C	5.00	0.44	5.66	0.20	0.91	6.70	6.13	18	160	0.0075	6.08	10.75	0.0110	WITHIN CAPACITY	1
CB B11 - DMH B4	STDA B11	C	5.00	0.14	6.10	0.15	1.06	6.70	7.13	18	51	0.0075	6.08	10.75	0.0110	WITHIN CAPACITY	1.1
DMH B4 - CB B12	N/A	C	5.00	0.30	6.24	0.00	1.06	6.70	7.13	18	108	0.0075	6.08	10.75	0.0110	WITHIN CAPACITY	1.1
CB B12 - BASIN B	STDA B12	C	5.00	0.10	6.49	0.09	1.73	6.70	11.61	24	48	0.0083	7.75	24.36	0.0110	WITHIN CAPACITY	0.95
CB C1 - CB C2	STDA C1	I	5.00	0.08	5.00	0.21	0.21	6.70	1.42	15	31	0.0100	6.22	7.63	0.0110	WITHIN CAPACITY	0.5
CB C2 - DMH C1	STDA C2	C	5.00	0.07	5.08	0.11	0.33	6.70	2.19	15	102	0.1430	23.52	28.87	0.0110	WITHIN CAPACITY	0.65
DMH C1 - DP1	N/A	C	5.00	0.19	5.16	0.00	0.33	6.70	2.19	15	161	0.0500	13.91	17.07	0.0110	WITHIN CAPACITY	0.65
CB D1 - WQS D2	STDA D	I	5.00	0.11	5.00	0.14	0.14	6.70	0.97	15	40	0.0100	6.22	7.63	0.0110	WITHIN CAPACITY	<0.5
CB E1 - DP5	STDA E	I	5.00	0.11	5.00	0.48	0.48	6.70	3.19	15	36	0.0075	5.39	6.61	0.0110	WITHIN CAPACITY	0.85

Appendix E – Outlet Protection Calculations

Channel Report

Hydroware Express Extension for Autodesk® AutoCAD® Civil 3D® by Autodesk, Inc.

Thursday, Sep 25 2014

CB A7 to Basin A

Circular Diameter (ft) = 1.50
Invert Elev (ft) = 820.00
Slope (%) = 1.95
N-Value = 0.011
Calculations Compute by: Known Q
Known Q (cfs) = 5.19

Highlighted Depth (ft)
Q (cfs)
Area (sqft)
Velocity (ft/s)
Wetted Perim (ft)
Crit Depth, Yc (ft)
Top Width (ft)
EGL (ft)

= 0.57
 = 5.190
 = 0.62
 = 8.40
 = 1.99
 = 0.88
 = 1.46
 = 1.67

INTERMEDIATE
RIPRAP

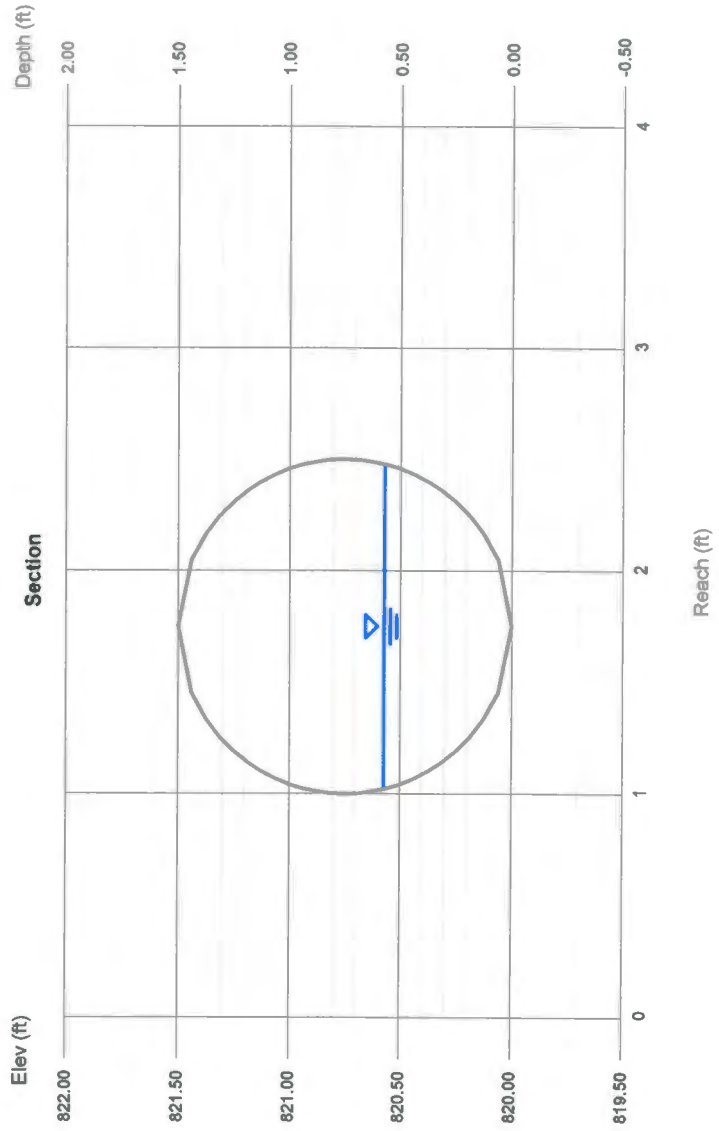

OUTLET PROTECTION - OUTLET VELOCITY ≤ 14 feet/sec

DISCHARGE (cfs)	OUTLET PIPE DIAMETER OR SPAN (in)										
	12	15	18	24	30	36	42	48	54	60	
0-5	10	10		USE							
6	12	11									
7		13	12								
8		14	13	12		MINIMUM					
9			14	13							
10			15	13							
11			16	14				LENGTH			
12				14							
14				16	14						
16				17	15	14			OUTLINED		
18				18	16	15					
20					17	15	14				
22		USE			18	16	15				
24						17	15	14			
26						17	16	15			
28						18	16	15			
30						19	17	16			
35						20	18	17	16		
40			PREFORMED					20	18	17	16
45							21	19	18	16	
50							22	20	18	17	
55								21	19	18	
60								22	20	19	
65								24	21	20	
70					SCOUR				25	22	20
75								26	23	21	
80									24	22	
90									26	24	
100									28	25	
110										27	
125							HOLE			29	
130										30	

Table 8-6.1 - Length - L_a (feet)
Type A Riprap Apron

- Notes: 1. Bold face outlined boxes indicate minimum L_a to be used for a given pipe diameter or span.
- 2. Rounding and interpolating are acceptable.

$$W = 3S_p + 0.4L_a = 9.3'$$

USE 9.5'W x 12'L Intermediate Riprap.

Channel Report

Hydrow Express Extension for Autodesk® AutoCAD® CMI 3D® by Autodesk, Inc.

Thursday, Sep 25 2014

CB A21 to Basin A

Circular Diameter (ft) = 2.00
Invert Elev (ft) = 820.00
Slope (%) = 0.83
N-Value = 0.011
Calculations
Compute by: Known Q
Known Q (cfs) = 14.55

Highlighted
Depth (ft)
Q (cfs)
Area (sqft)
Velocity (ft/s)
Wetted Perim (ft)
Crit Depth, Yc (ft)
Top Width (ft)
EGL (ft)

= 1.11
 = 14.55
 = 1.80
 = 8.09
 = 3.37
 = 1.38
 = 1.99
 = 2.13

INTERMEDIATE
RIPRAP

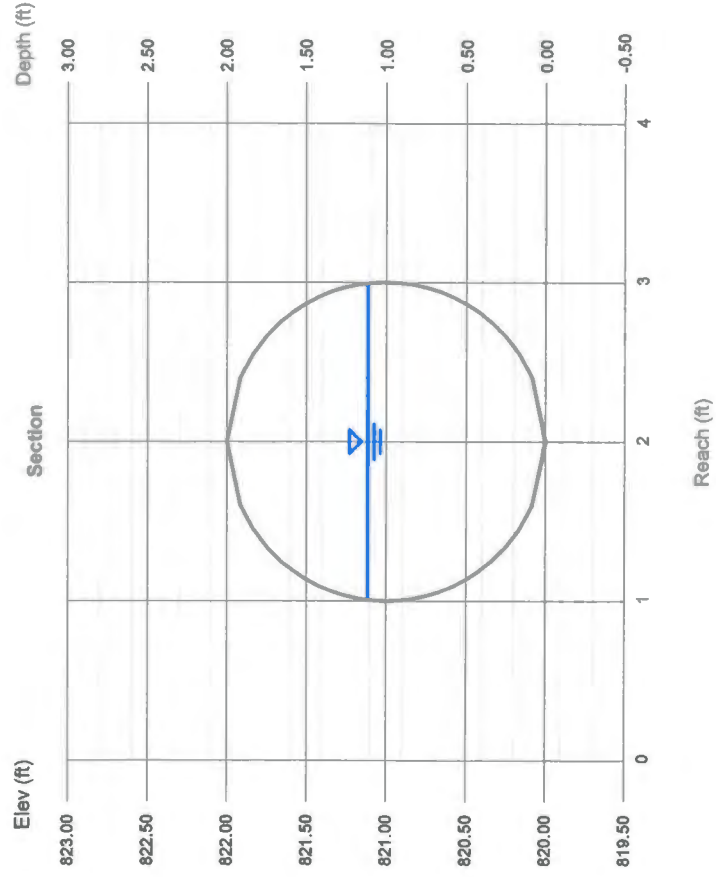

OUTLET PROTECTION - OUTLET VELOCITY ≤ 14 feet/sec

DISCHARGE (cfs)	OUTLET PIPE DIAMETER OR SPAN (in)										
	12	15	18	24	30	36	42	48	54	60	
0-5	10	10		<i>USE</i>							
6	12	11									
7		13	12								
8		14	13	12		<i>MINIMUM</i>					
9			14	13							
10			15	13							
11			16	14				<i>LENGTH</i>			
12				14							
14				16	14						
16				17	15	14			<i>OUTLINED</i>		
18				18	16	15					
20					17	15	14				
22		<i>USE</i>			18	16	15				
24						17	15	14			
26						17	16	15			
28						18	16	15			
30						19	17	16			
35						20	18	17	16		
40			<i>PREFORMED</i>					20	18	17	16
45							21	19	18	16	
50							22	20	18	17	
55								21	19	18	
60								22	20	19	
65								24	21	20	
70					<i>SCOUR</i>				25	22	20
75								26	23	21	
80									24	22	
90									26	24	
100									28	25	
110										27	
125							<i>HOLE</i>			29	
130										30	

Table 8-6.1 - Length - L_a (feet)
Type A Riprap Apron

- Notes: 1. Bold face outlined boxes indicate minimum L_a to be used for a given pipe diameter or span.
- 2. Rounding and interpolating are acceptable.

$$W = 3S_p + 0.4L_a = 12.4'$$

USE 12.5'W x 16'L Intermediate Riprap.

Channel Report

Hydraulics Express Extension for Autodesk AutoCAD® Civil 3D® by Autodesk, Inc.

Thursday, Sep 25 2014

CB B12 to Basin B

Circular Diameter (ft) = 2.00
Invert Elev (ft) = 821.00
Slope (%) = 0.83
N-Value = 0.011
Calculations
Compute by: Known Q
Known Q (cfs) = 11.61

Highlighted
Depth (ft)
Q (cfs)
Area (sqft)
Velocity (ft/s)
Wetted Perim (ft)
Crit Depth, Yc (ft)
Top Width (ft)
EGL (ft)

= 0.97
 = 11.61
 = 1.52
 = 7.64
 = 3.09
 = 1.23
 = 2.00
 = 1.88

MODIFIED
 RIPRAP

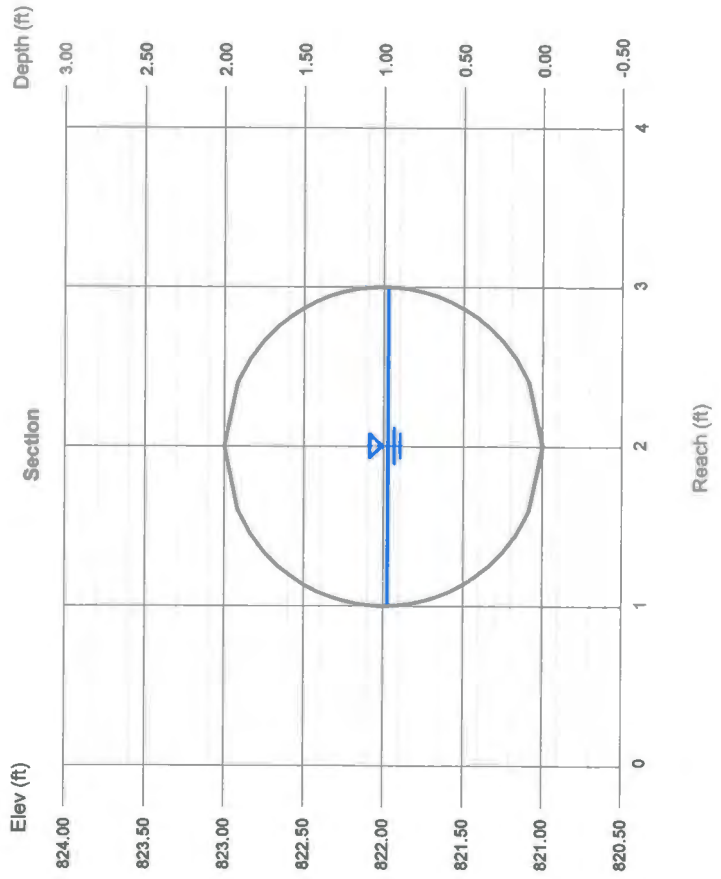

OUTLET PROTECTION - OUTLET VELOCITY \leq 14 feet/sec

DISCHARGE (cfs)	OUTLET PIPE DIAMETER OR SPAN (in)									
	12	15	18	24	30	36	42	48	54	60
0-5	10	10		<i>USE</i>						
6	12	11								
7		13	12							
8		14	13	12		<i>MINIMUM</i>				
9			14	13						
10			15	13						
11			16	14				<i>LENGTH</i>		
12				14						
14				16	14					
16				17	15	14			<i>OUTLINED</i>	
18				18	16	15				
20					17	15	14			
22		<i>USE</i>			18	16	15			
24						17	15	14		
26						17	16	15		
28						18	16	15		
30						19	17	16		
35						20	18	17	16	
40			<i>PREFORMED</i>				20	18	17	16
45						21	19	18	16	
50						22	20	18	17	
55							21	19	18	
60							22	20	19	
65							24	21	20	
70					<i>SCOUR</i>			25	22	20
75							26	23	21	
80								24	22	
90								26	24	
100								28	25	
110										27
125							<i>HOLE</i>			29
130										30

Table 8-6.1 - Length - L_a (feet)
Type A Riprap Apron

- Notes: 1. Bold face outlined boxes indicate minimum L_a to be used for a given pipe diameter or span.
- 2. Rounding and interpolating are acceptable.

$$W = 3S_p + 0.4L_a = 11.6'$$

USE 12'W x 14'L Modified Riprap

Channel Report

Hydroware Express Extension for Autodesk® AutoCAD® Civil 3D® by Autodesk, Inc.

Thursday, Sep 25 2014

CB D1 to WQS D2

Circular
Diameter (ft)

= 1.25

Invert Elev (ft)

= 800.35

Slope (%)

= 1.00

N-Value

= 0.011

Calculations

Compute by:

Known Q

Known Q (cfs)

= 0.97

Highlighted

Depth (ft)

= 0.31

Q (cfs)

= 0.970

Area (sqft)

= 0.24

Velocity (ft/s)

= 4.06

Wetted Perim (ft)

= 1.31

Crit Depth, Yc (ft)

= 0.39

Top Width (ft)

= 1.08

EGL (ft)

= 0.57

MODIFIED
RIPRAP

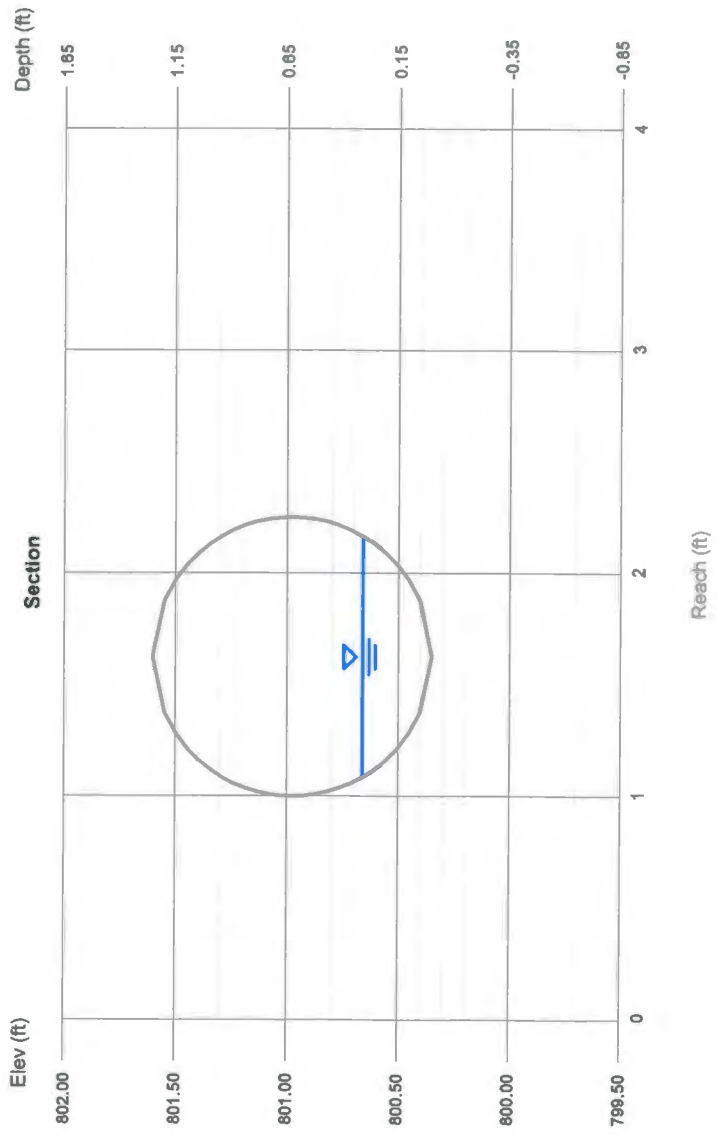

OUTLET PROTECTION - OUTLET VELOCITY \leq 14 feet/sec

DISCHARGE (cfs)	OUTLET PIPE DIAMETER OR SPAN (in)										
	12	15	18	24	30	36	42	48	54	60	
0-5	10	10		<i>USE</i>							
6	12	11									
7		13	12								
8		14	13	12		<i>MINIMUM</i>					
9			14	13							
10			15	13							
11			16	14				<i>LENGTH</i>			
12				14							
14				16	14						
16				17	15	14				<i>OUTLINED</i>	
18				18	16	15					
20					17	15	14				
22		<i>USE</i>			18	16	15				
24						17	15	14			
26						17	16	15			
28						18	16	15			
30						19	17	16			
35						20	18	17	16		
40			<i>PREFORMED</i>					20	18	17	16
45							21	19	18	16	
50							22	20	18	17	
55								21	19	18	
60								22	20	19	
65								24	21	20	
70						<i>SCOUR</i>		25	22	20	
75								26	23	21	
80									24	22	
90									26	24	
100									28	25	
110										27	
125							<i>HOLE</i>			29	
130										30	

**Table 8-6.1 - Length - L_a (feet)
Type A Riprap Apron**

- Notes: 1. Bold face outlined boxes indicate minimum L_a to be used for a given pipe diameter or span.
2. Rounding and interpolating are acceptable.

$$W = 3S_p + 0.4L_a = 7.75'$$

USE 8' W x 10' L MODIFIED RIPRAP

Channel Report

Hydroflow Express Extension for Autodesk® AutoCAD® Civil 3D® by Autodesk, Inc.

Thursday, Sep 25 2014

DMH C1 to DP1

Circular Diameter (ft) = 1.25
Invert Elev (ft) = 778.50
Slope (%) = 5.00
N-Value = 0.011
Calculations
 Compute by: Known Q
 Known Q (cfs) = 2.19

Highlighted
Depth (ft)
Q (cfs)
Area (sqft)
Velocity (ft/s)
Wetted Perim (ft)
Crit Depth, Yc (ft)
Top Width (ft)
EGL (ft)

= 0.31
 = 2.190
 = 0.24
 = 9.18
 = 1.31
 = 0.60
 = 1.08
 = 1.62

INTERMEDIATE
RIP RAP

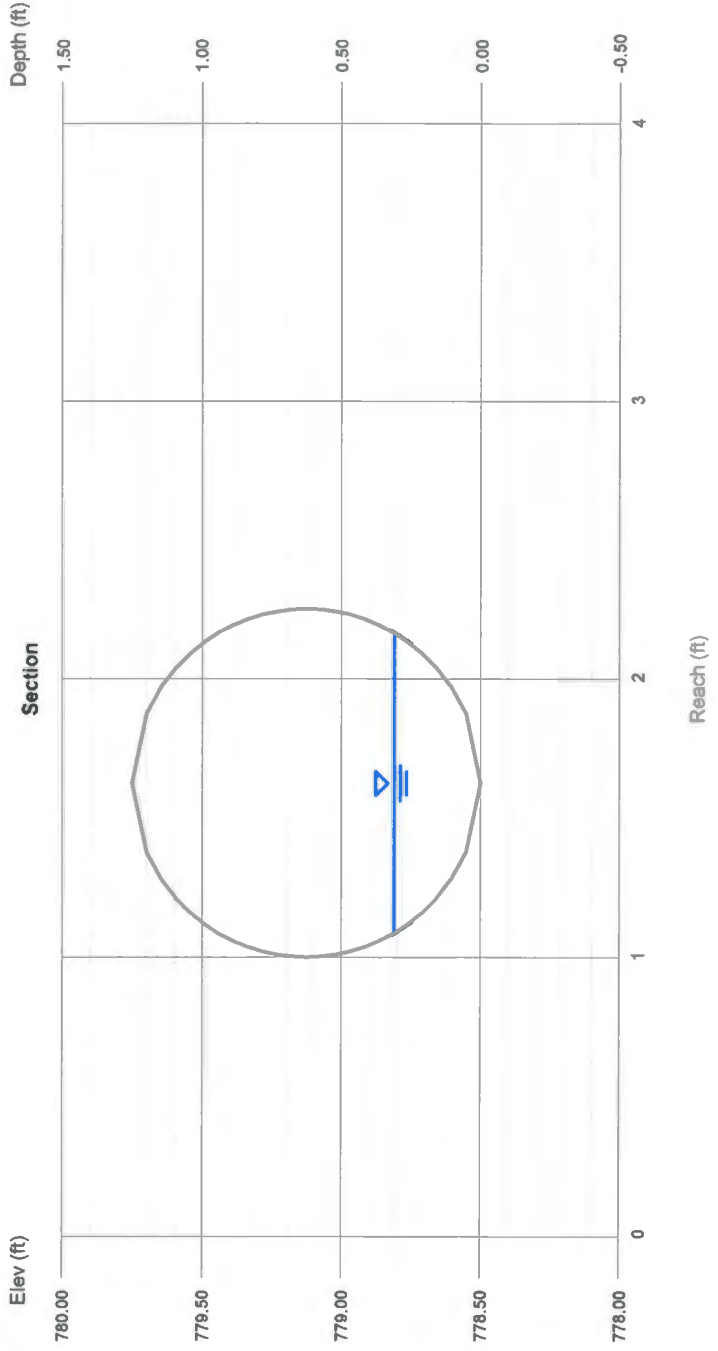

OUTLET PROTECTION - OUTLET VELOCITY \leq 14 feet/sec

DISCHARGE (cfs)	OUTLET PIPE DIAMETER OR SPAN (in)										
	12	15	18	24	30	36	42	48	54	60	
0-5	10	10		USE							
6	12	11									
7		13	12								
8		14	13	12		MINIMUM					
9			14	13							
10			15	13							
11			16	14				LENGTH			
12				14							
14				16	14						
16				17	15	14			OUTLINED		
18				18	16	15					
20					17	15	14				
22		SE			18	16	15				
24						17	15	14			
26						17	16	15			
28						18	16	15			
30						19	17	16			
35						20	18	17	16		
40			PREFORMED					20	18	17	16
45							21	19	18	16	
50							22	20	18	17	
55								21	19	18	
60								22	20	19	
65								24	21	20	
70					SCOUR				25	22	20
75								26	23	21	
80									24	22	
90									26	24	
100									28	25	
110										27	
125							HOLE			29	
130										30	

Table 8-6.1 - Length - L_a (feet)

Type A Riprap Apron

- Notes: 1. Bold face outlined boxes indicate minimum L_a to be used for a given pipe diameter or span.
- 2. Rounding and interpolating are acceptable.

$$W = 3S_p + 0.4L_a = 7.75'$$

USE 8'W x 10'L Intermediate Riprap

Channel Report

Hydraflow Express Extension for Autodesk® AutoCAD® Civil 3D® by Autodesk, Inc.

Thursday, Sep 25 2014

DMH B9 to DP1

Circular Diameter (ft) = 2.00
Invert Elev (ft) = 778.50
Slope (%) = 2.50
N-Value = 0.011
Calculations Compute by: Known Q
Known Q (cfs) = 5.43

Highlighted Depth (ft)
Q (cfs)
Area (sqft)
Velocity (ft/s)
Wetted Perim (ft)
Crit Depth, Yc (ft)
Top Width (ft)
EGL (ft)

= 0.49
 = 5.430
 = 0.60
 = 9.00
 = 2.08
 = 0.83
 = 1.72
 = 1.75

INTERMEDIATE
RIP RAP

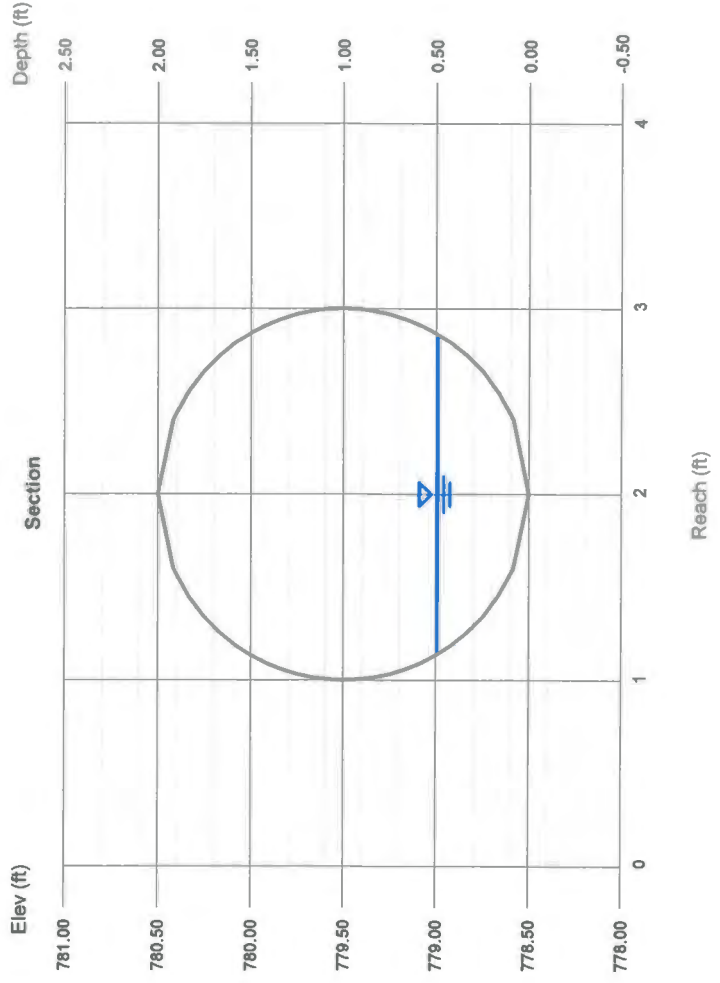

OUTLET PROTECTION - OUTLET VELOCITY ≤ 14 feet/sec

DISCHARGE (cfs)	OUTLET PIPE DIAMETER OR SPAN (in)										
	12	15	18	24	30	36	42	48	54	60	
0-5	10	10		USE							
6	12	11									
7		13	12								
8		14	13	12		MINIMUM					
9			14	13							
10			15	13							
11			16	14				LENGTH			
12				14							
14				16	14						
16				17	15	14				OUTLINED	
18				18	16	15					
20					17	15	14				
22		USE			18	16	15				
24						17	15	14			
26						17	16	15			
28						18	16	15			
30						19	17	16			
35						20	18	17	16		
40			PREFORMED					20	18	17	16
45							21	19	18	16	
50							22	20	18	17	
55								21	19	18	
60								22	20	19	
65								24	21	20	
70						SCOUR		25	22	20	
75								26	23	21	
80									24	22	
90									26	24	
100									28	25	
110										27	
125							HOLE			29	
130										30	

**Table 8-6.1 - Length - L_a (feet)
Type A Riprap Apron**

- Notes: 1. Bold face outlined boxes indicate minimum L_a to be used for a given pipe diameter or span.
- 2. Rounding and interpolating are acceptable.

$$W = 3S_p + 0.4L_a = 10.8'$$

USE 11'W x 12'L Intermediate Riprap

Channel Report

Hydrotol Express Extension for Autodesk® AutoCAD® Civil 3D® by Autodesk, Inc.

Tuesday, Feb 04 2015

DP1 Outlet

Circular
Diameter (ft) = 2.00

Invert Elev (ft) = 760.00
Slope (%) = 13.50
N-Value = 0.011

Calculations
Compute by: Known Q
Known Q (cfs) = 21.65

Highlighted
Depth (ft)
Q (cfs)
Area (sqft)
Velocity (ft/s)
Wetted Perim (ft)
Crit Depth, Yc (ft)
Top Width (ft)
EGL (ft)

= 0.64
= 21.65
= 0.87
= **24.86**
= 2.41
= 1.67
= 1.87
= 10.25

**TYPE 1
PERFORMED
SCOUR**

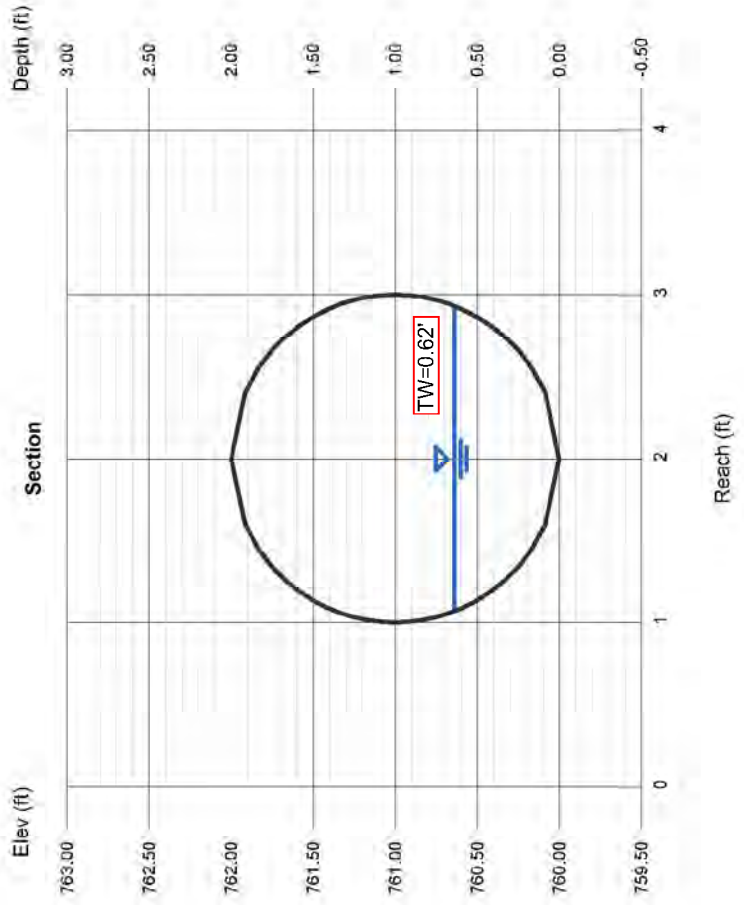

OUTLET PROTECTION
OUTLET VELOCITY > 14 feet/sec or Length of Apron exceeds limits shown on
Tables 8-6.1 and 8-7.1

Preformed Scour Hole										
(See Figure 8-11)	PIPE DIAMETER (in)									
	12	15	18	24	30	36	42	48	54	60
Type 1										
B	5	6	8	10	13	15	18	20	23	25
C	6	8	9	12	15	18	21	24	27	30
d	Depends on riprap type(see Figure 8-11)									
2S_p	2.0	2.6	3.0	4.0	5.0	6.0	7.0	8.0	9.0	10.0
3S_p	3.0	3.9	4.5	6.0	7.5	9.0	10.5	12.0	13.5	15.0
F = 0.5 S_p	0.5	0.625	0.75	1	1.25	1.5	1.75	2	2.25	2.5
Type 2										
B	8	10	12	16	20	24	28	32	36	40
C	9	11	14	18	23	27	32	36	41	45
d	Depends on riprap size (see Figure 8-11)									
2S_p	2.0	2.6	3.0	4.0	5.0	6.0	7.0	8.0	9.0	10.0
3S_p	3.0	3.9	4.5	6.0	7.5	9.0	10.5	12.0	13.5	15.0
F = S_p	1.0	1.3	1.5	2.0	2.5	3.0	3.5	4.0	4.5	5.0

Table 8-8.1 - Dimensions of Preformed Scour Hole (Feet)

$$d_{50} = (0.0125 R_p^2 / TW) (Q / R_p^{2.5})^{1.333} = 0.483'$$

0.42' < d₅₀ < 0.67' Use Intermediate Riprap

10' W × 12' L × 1' D Type 1 Scour Hole

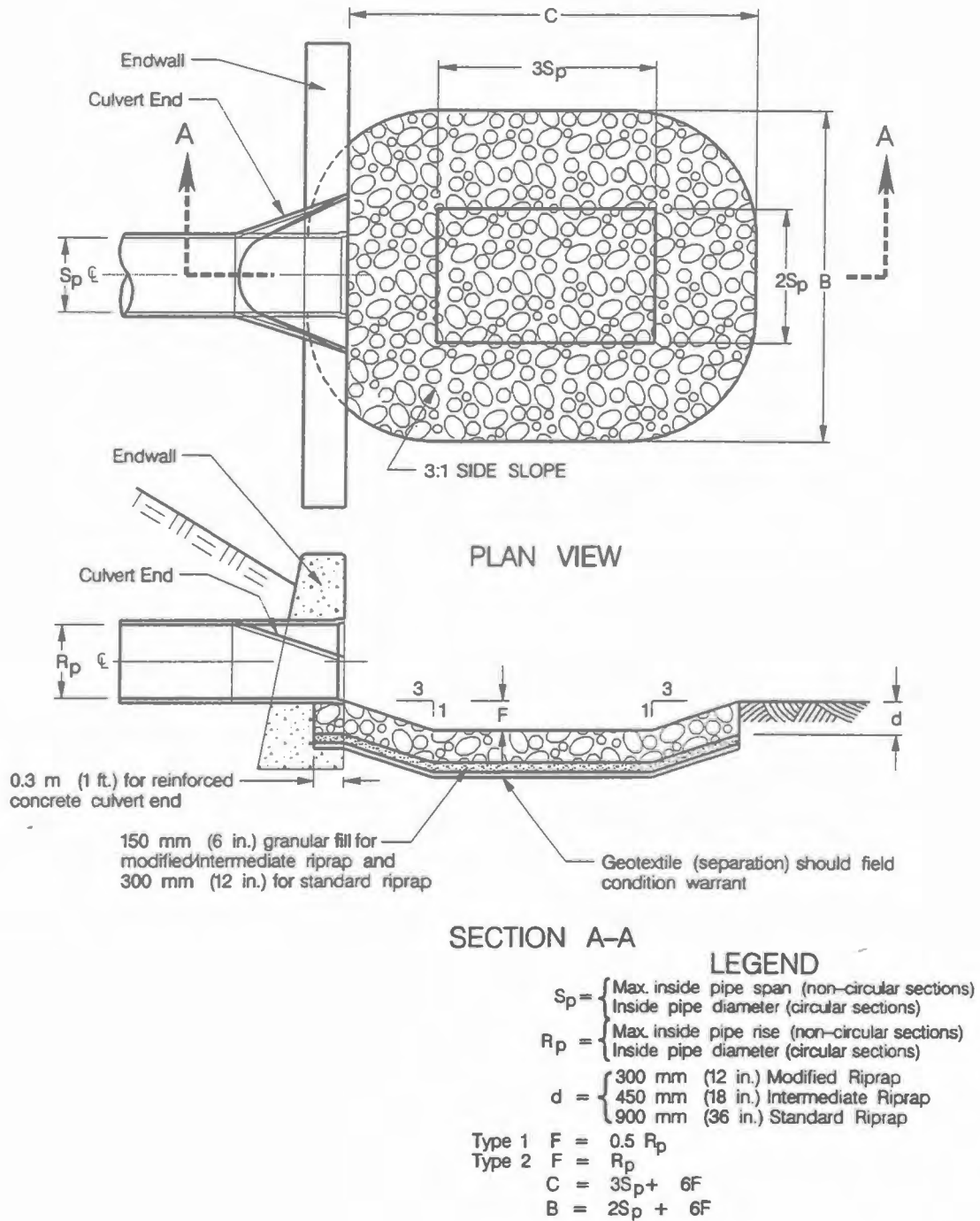

Figure 8-11 Preformed Scour Hole Type 1 and Type 2

Appendix F – Water Quality Volume Calculations

**WATER QUALITY VOLUME CALCULATIONS FOR
CPV Towantic Energy Center
(PER DEP 2004 STORMWATER QUALITY MANUAL)
9-23-14
Revised 2-13-15**

Water Quality Volume (WQV) = $1" \times R \times A / 12$

Where: R = Volumetric Runoff Coefficient = $0.05 + 0.009 \times I$
I = Percent impervious cover
A = Site area in acres

TO STORMWATER RENOVATION AREA "A"

A = 8.81 acres
I = 2.28 ac = 25.9%
R = $0.05 + 0.009 \times 25.9 = 0.283$
WQV (Drainage Area) = $1" \times 0.283 \times 8.81 / 12 = .208 \text{ ac-ft} = 9,050 \text{ CF}$
WQV Required = 9,050 CF

WVQ Provided in Forebay Area = 6,025 CF
WVQ Provided in Low Marsh Swale = 4,050 CF
WQV Provided in Micro-pool = 5,200 CF

Total volume provided by Forebay and Micro-pool in Renovation Area "A" = 15,275 CF (169% of required)

TO STORMWATER RENOVATION AREA "B"

A = 8.72 acres
I = 0.92 ac = 10.6%
R = $0.05 + 0.009 \times 10.6 = 0.145$
WQV (Drainage Area) = $1" \times 0.145 \times 8.72 / 12 = .105 \text{ ac-ft} = 4,590 \text{ CF}$
WQV Required = 4,590 CF

WVQ Provided in Forebay Area = 1,140 CF
WVQ Provided in Low Marsh Swale = 2,160 CF
WQV Provided in Micro-pool = 3,650 CF

Total volume provided by Forebay and Micro-pool in Renovation Area "B" = 6,950 CF (151% of required)

Appendix G – Water Quality Swale Analysis

Channel Report

Hydrow Express Extension for Autodesk® AutoCAD® Civil 3D® by Autodesk, Inc.

Thursday, Sep 25 2014

WQS C

Trapezoidal

Bottom Width (ft) = 3.00
 Side Slopes (z:1) = 3.00, 3.00
 Total Depth (ft) = 2.50
 Invert Elev (ft) = 808.00
 Slope (%) = 5.00
 N-Value = 0.035

Calculations

Compute by: Known Q
 Known Q (cfs) = 1.42

Highlighted

Depth (ft) = 0.17
 Q (cfs) = 1.420
 Area (sqft) = 0.60
 Velocity (ft/s) = 2.38
 Wetted Perim (ft) = 4.08
 Crit Depth, Yc (ft) = 0.18
 Top Width (ft) = 4.02
 EGL (ft) = 0.26

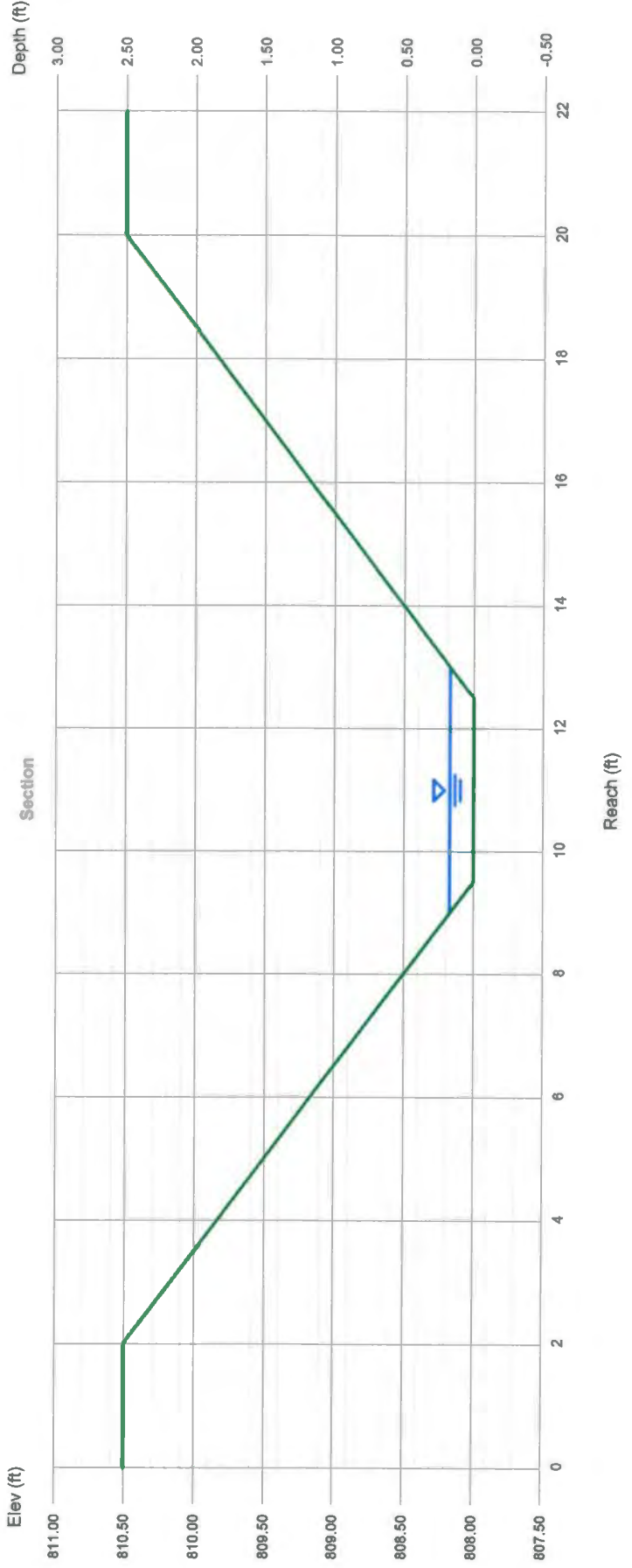

Channel Report

Hydroflow Express Extension for Autodesk® AutoCAD® Civil 3D® by Autodesk, Inc.

Thursday, Sep 25 2014

WQS D1

Trapezoidal

Bottom Width (ft) = 3.00
 Side Slopes (z:1) = 3.00, 3.00
 Total Depth (ft) = 2.50
 Invert Elev (ft) = 804.00
 Slope (%) = 2.00
 N-Value = 0.035

Calculations

Compute by: Known Q
 Known Q (cfs) = 0.97

Highlighted

Depth (ft) = 0.17
 Q (cfs) = 0.970
 Area (sqft) = 0.60
 Velocity (ft/s) = 1.63
 Wetted Perim (ft) = 4.08
 Crit Depth, Yc (ft) = 0.15
 Top Width (ft) = 4.02
 EGL (ft) = 0.21

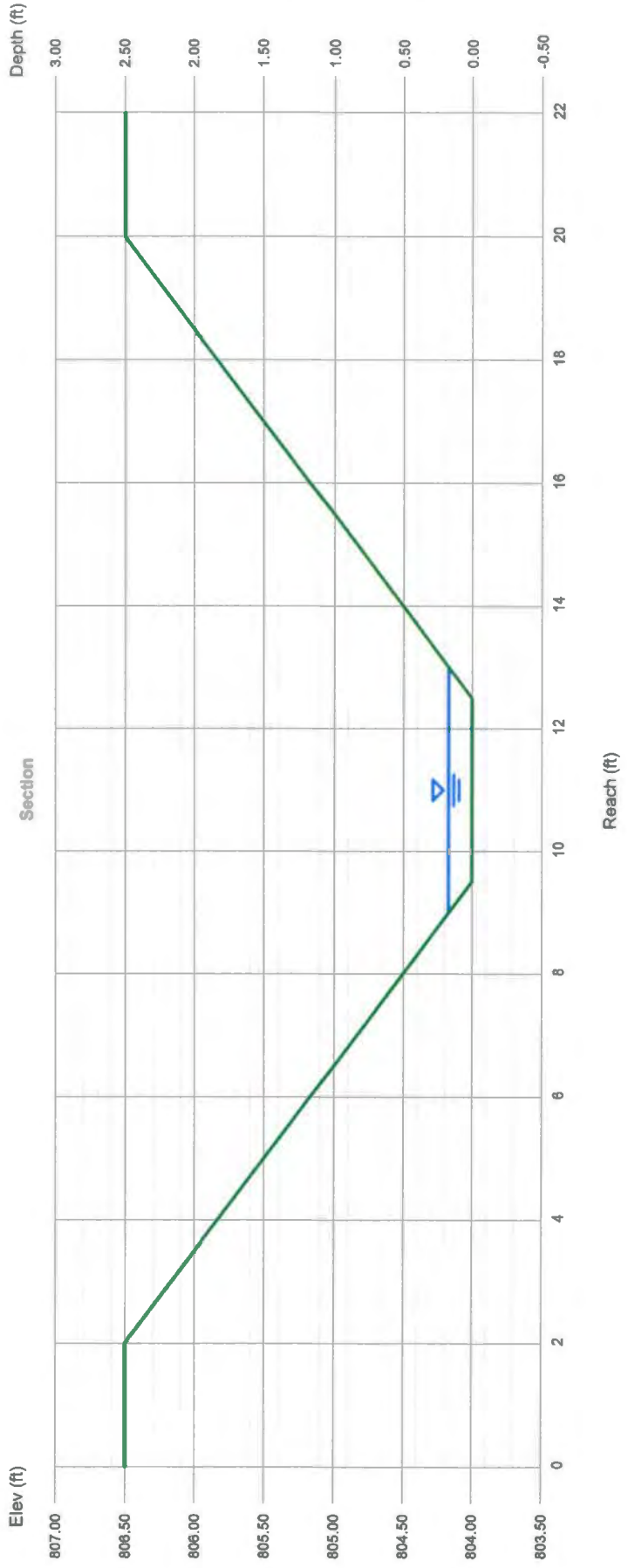

Channel Report

Hydroflow Express Extension for Autodesk® AutoCAD® Civil 3D® by Autodesk, Inc.

Thursday, Sep 25 2014

WQS D2

Trapezoidal

Bottom Width (ft) = 3.00
 Side Slopes (z:1) = 3.00, 3.00
 Total Depth (ft) = 2.50
 Invert Elev (ft) = 763.50
 Slope (%) = 5.50
 N-Value = 0.035

Calculations

Compute by: Known Q
 Known Q (cfs) = 4.43

Highlighted

Depth (ft) = 0.30
 Q (cfs) = 4.430
 Area (sqft) = 1.17
 Velocity (ft/s) = 3.79
 Wetted Perim (ft) = 4.90
 Crit Depth, Yc (ft) = 0.36
 Top Width (ft) = 4.80
 EGL (ft) = 0.52

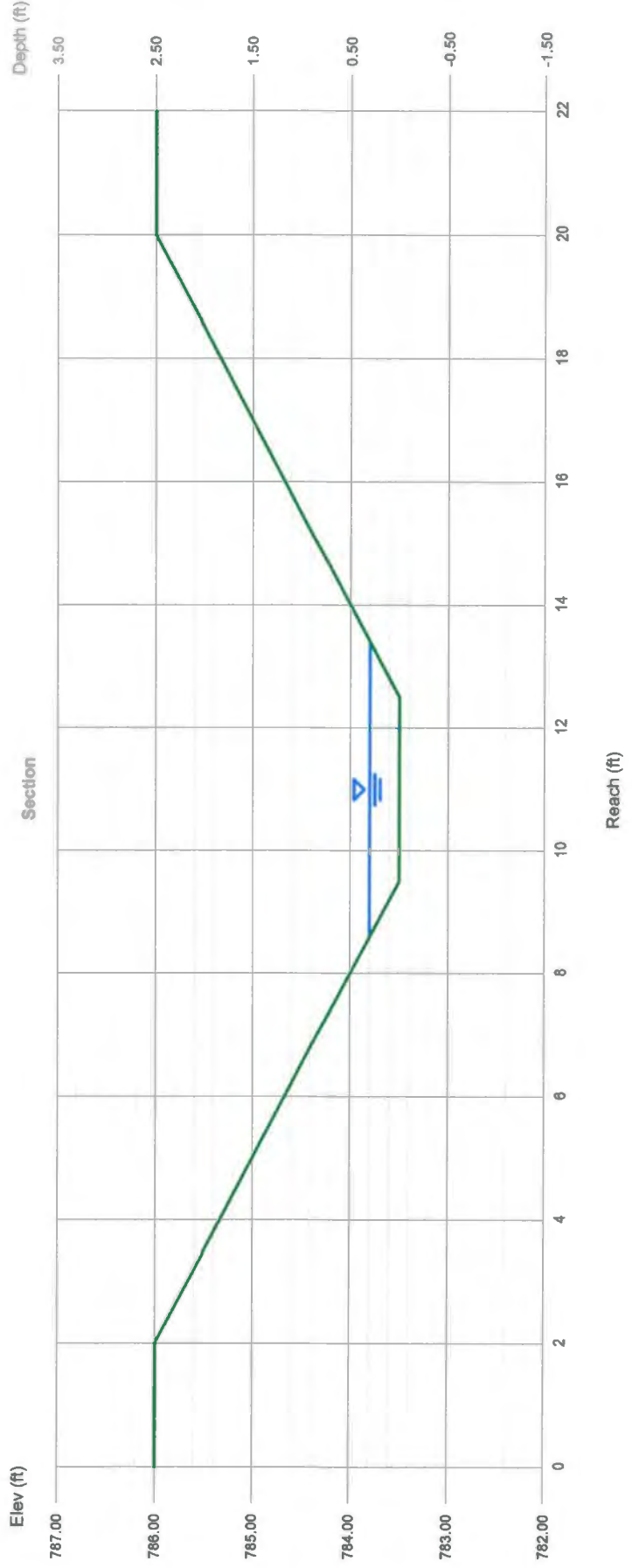

Channel Report

Hydrow Express Extension for Autodesk AutoCAD® Civil 3D® by Autodesk, Inc.

Thursday, Sep 25 2014

WQS E1

Trapezoidal

Bottom Width (ft) = 3.00, 3.00
 Side Slopes (z:1) = 2.50
 Total Depth (ft) = 790.25
 Invert Elev (ft) = 6.00
 Slope (%) = 0.035
 N-Value

Calculations

Compute by: Known Q
 Known Q (cfs) = 1.52

Highlighted

Depth (ft) = 0.16
 Q (cfs) = 1.520
 Area (sqft) = 0.56
 Velocity (ft/s) = 2.73
 Wetted Perim (ft) = 4.01
 Crit Depth, Yc (ft) = 0.19
 Top Width (ft) = 3.96
 EGL (ft) = 0.28

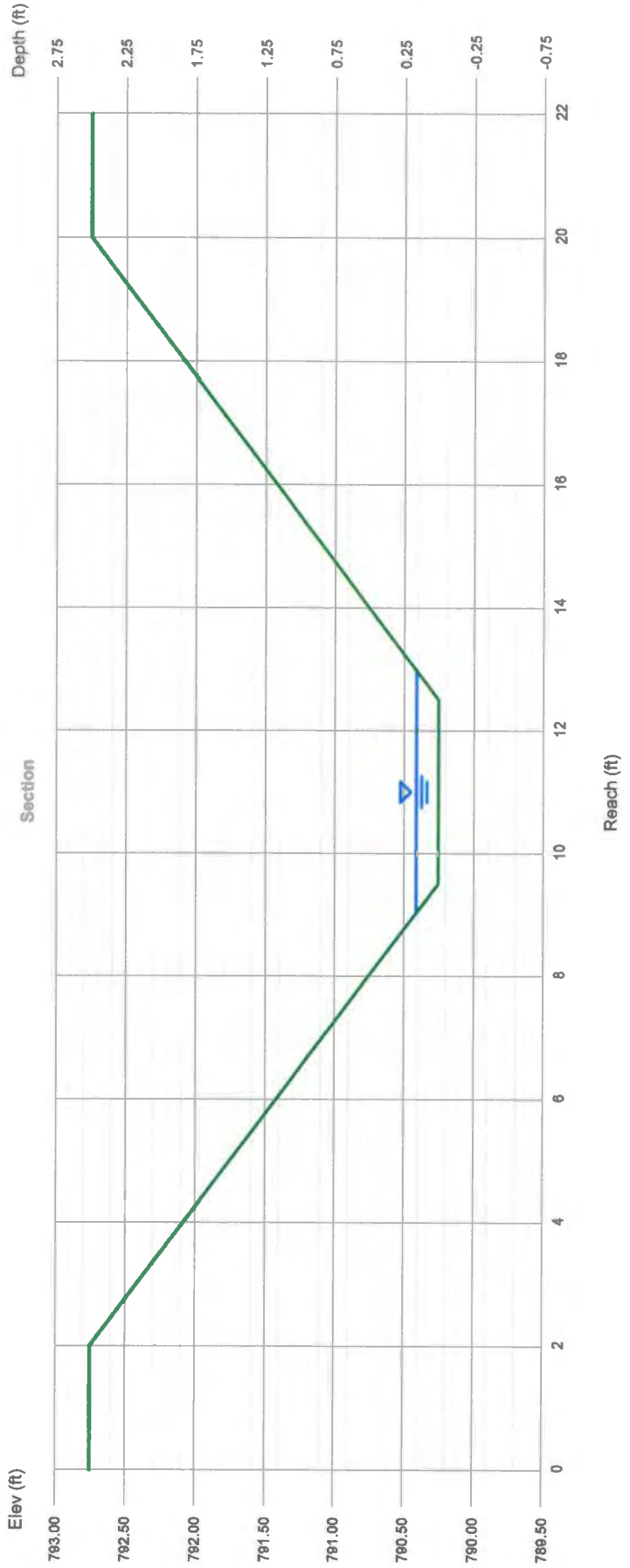

Channel Report

Hydrowflow Express Extension for Autodesk® AutoCAD® Civil 3D® by Autodesk, Inc.

Thursday, Sep 25 2014

WQS E2

Trapezoidal

Bottom Width (ft) = 3.00, 3.00
 Side Slopes (z:1) = 2.50
 Total Depth (ft) = 790.25
 Invert Elev (ft) = 2.50
 Slope (%) = 0.035
 N-Value

Calculations

Compute by: Known Q
 Known Q (cfs) = 1.66

Highlighted

Depth (ft) = 0.22
 Q (cfs) = 1.660
 Area (sqft) = 0.81
 Velocity (ft/s) = 2.06
 Wetted Perim (ft) = 4.39
 Crit Depth, Yc (ft) = 0.20
 Top Width (ft) = 4.32
 EGL (ft) = 0.29

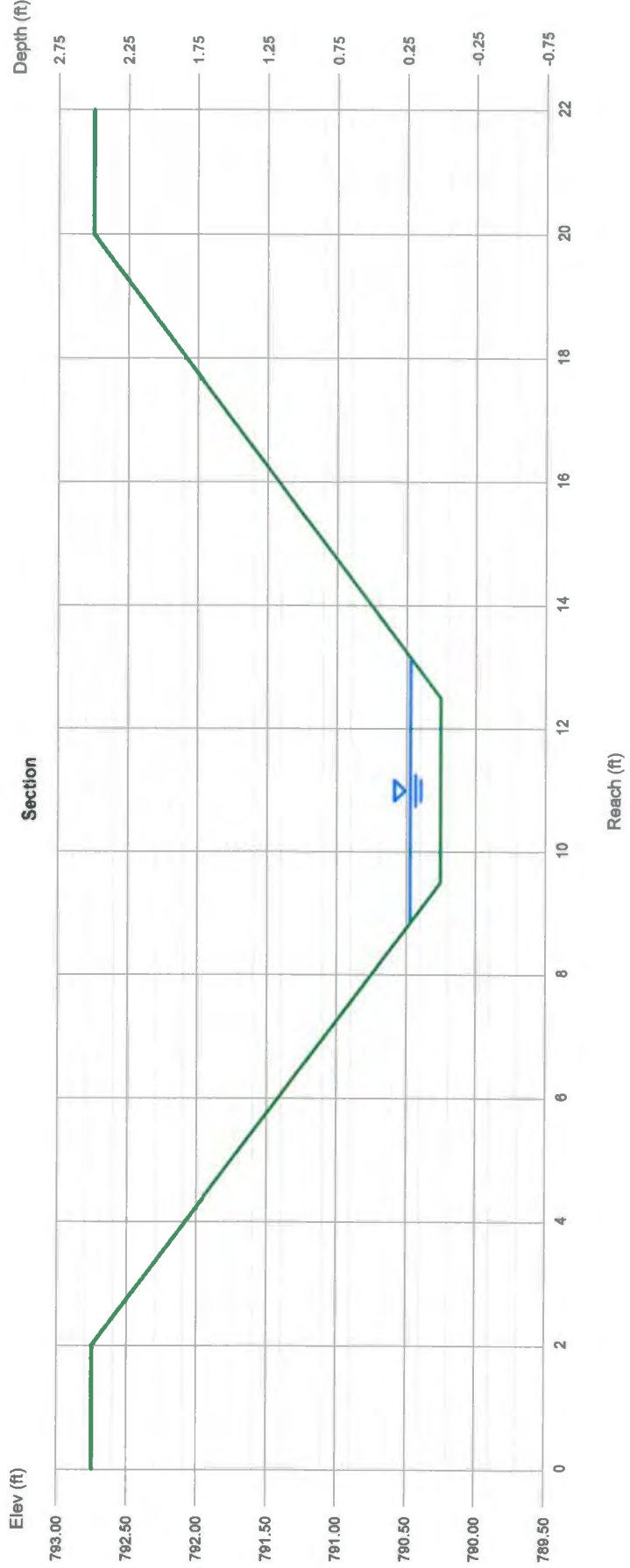

Channel Report

Hydration Express Extension for AutoCAD®/AutoCAD® Civil 3D® by Autodesk, Inc.

Friday, Feb 13 2015

WOODRUFF HILL ROADSIDE SWALE

Trapezoidal

Bottom Width (ft) = 2.00
Side Slopes (z:1) = 3.00, 3.00
Total Depth (ft) = 1.00
Invert Elev (ft) = 790.00
Slope (%) = 1.21
N-Value = 0.035

Calculations

Compute by: Known Q
Known Q (cfs) = 3.47

Highlighted

Depth (ft) = 0.47
Q (cfs) = 3.47C
Area (sqft) = 1.60
Velocity (ft/s) = **2.17**
Wetted Perim (ft) = 4.97
Crit Depth, Yc (ft) = 0.38
Top Width (ft) = 4.82
EGL (ft) = 0.54

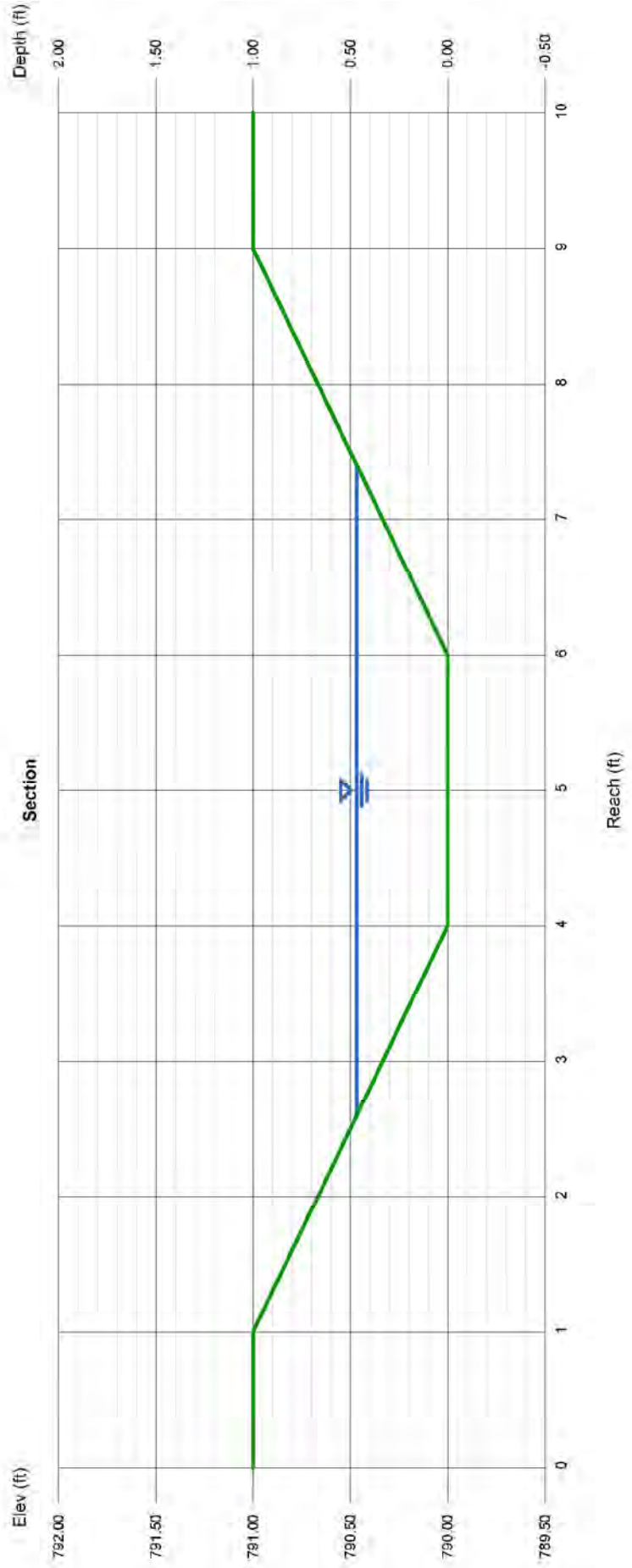

Channel Report

Hydration Express Extension for AutoCAD®/AutoCAD® Civil 3D® by Autodesk, Inc.

Friday, Feb 13 2015

WOODRUFF HILL ROADSIDE SWALE

Trapezoidal

Bottom Width (ft) = 2.00
 Side Slopes (z:1) = 3.00, 3.00
 Total Depth (ft) = 1.00
 Invert Elev (ft) = 790.00
 Slope (%) = 12.50
 N-Value = 0.035

Calculations

Compute by: Known Q
 Known Q (cfs) = 3.47

Highlighted

Depth (ft) = 0.26
 Q (cfs) = 3.47C
 Area (sqft) = 0.72
 Velocity (ft/s) = **4.80**
 Wetted Perim (ft) = 3.64
 Crit Depth, Yc (ft) = 0.38
 Top Width (ft) = 3.56
 EGL (ft) = 0.62

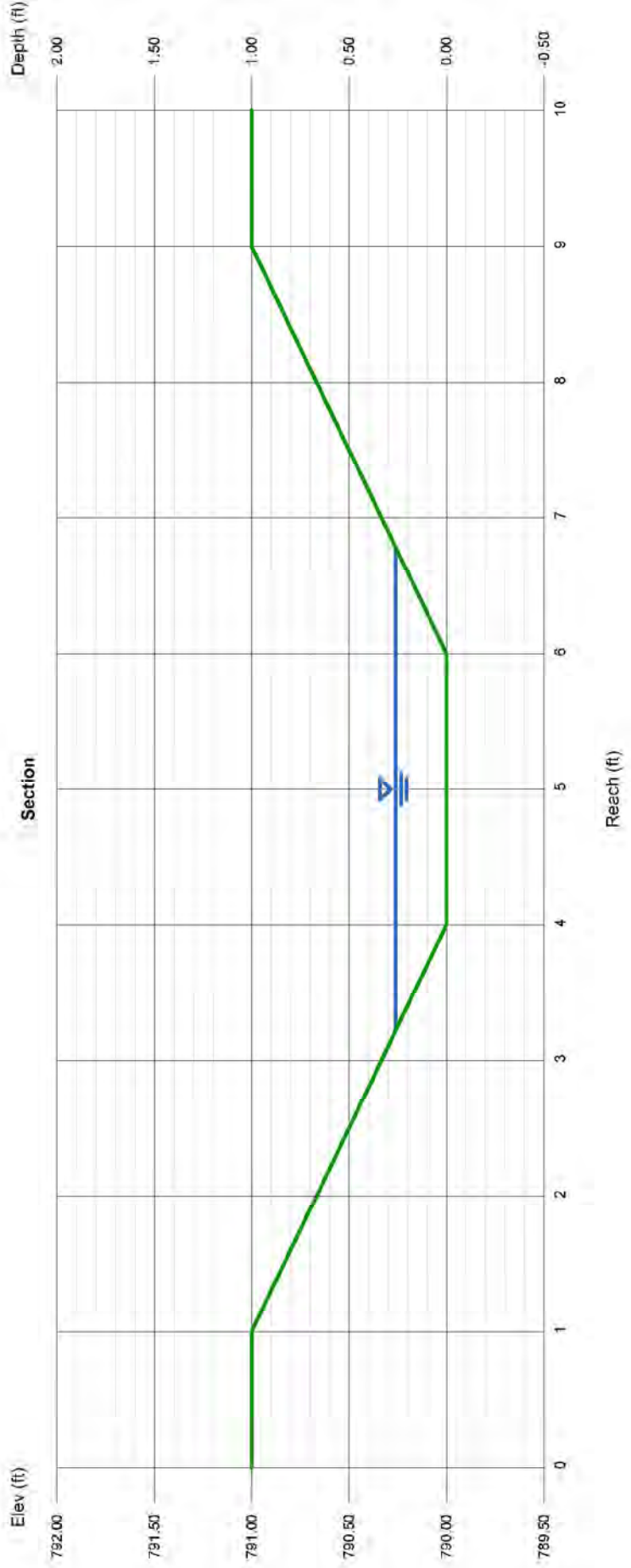

Appendix H – Temporary Sediment Trap Sizing

**TEMPORARY SEDIMENT TRAP SIZING FOR
CPV Towantic Energy Center
(PER 2002 CT DEP E&S MANUAL)
9-26-14**

TST A (STORMWATER RENOVATION AREA "A")

Initial Storage Volume = 134 cubic yards per acre of drainage area

$V = 134 \text{ cubic yards} \times 10.87 \text{ acres} = 1456.58 \text{ cubic yards}$

Half of Storage Volume will be wet and half dry = 728.29 cubic yards = 19,664 cubic feet

Vwet = provided in Pond below outlet elevation = 19,902 cubic feet

Vdry = provided in Pond above outlet elevation and below weir = 50,186 cubic feet

TST B (STORMWATER RENOVATION AREA "B")

Initial Storage Volume = 134 cubic yards per acre of drainage area

$V = 134 \text{ cubic yards} \times 5.88 \text{ acres} = 787.92 \text{ cubic yards}$

Half of Storage Volume will be wet and half dry = 393.96 cubic yards = 10,637 cubic feet

Vwet = provided in Pond below outlet elevation = 12,683 cubic feet

Vdry = provided in Pond above outlet elevation and below weir = 16,532 cubic feet

**Appendix I - CT DEEP General Permit for the Discharge of Stormwater
and Dewatering Wastewaters from Construction Activities**



General Permit for the Discharge of Stormwater and Dewatering Wastewaters from Construction Activities

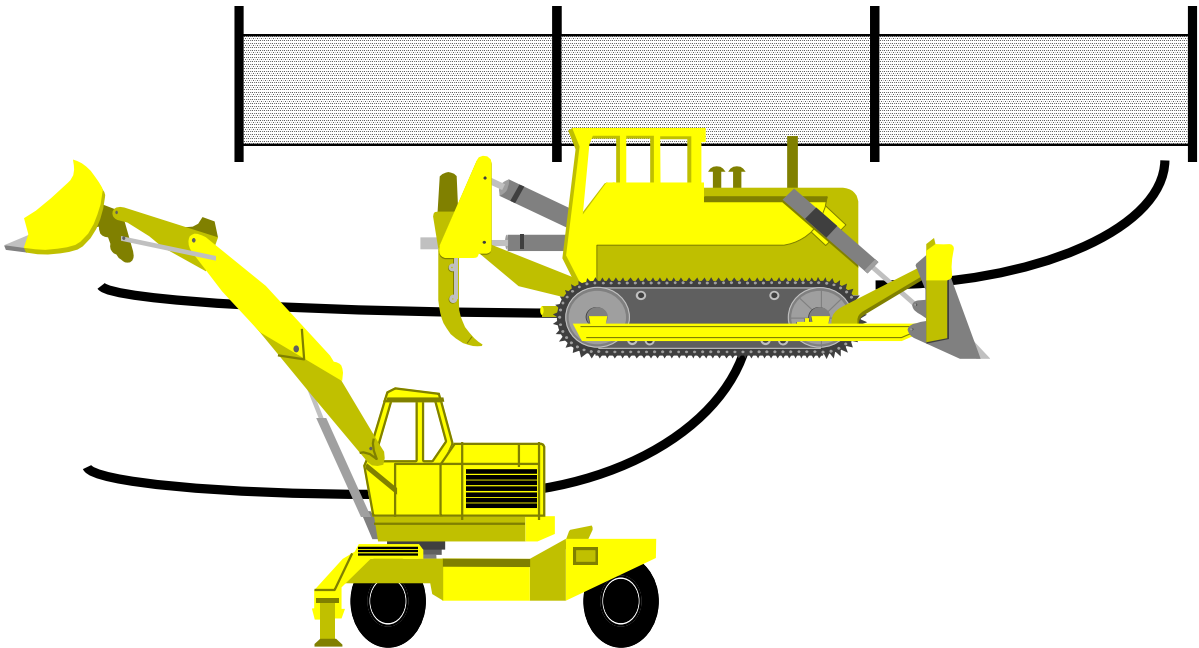

Issuance Date: August 21, 2013
Effective Date: October 1, 2013

Printed on recycled paper

General Permit for Discharge of Stormwater and Dewatering Wastewaters from Construction Activities

Table of Contents

Section 1.	Authority	4
Section 2.	Definitions	4
Section 3.	Authorization Under This General Permit	9
	(a) Eligible Activities	9
	(b) Requirements for Authorization	9
	(c) Registration.....	15
	(d) Small Construction	17
	(e) Geographic Area	17
	(f) Effective Date and Expiration Date of this General Permit.....	17
	(g) Effective Date of Authorization.....	17
	(h) Revocation of an Individual Permit	18
	(i) Issuance of an Individual Permit.....	18
Section 4.	Registration Requirements	18
	(a) Who Must File a Registration	18
	(b) Scope of Registration.....	18
	(c) Contents of Registration	18
	(d) Where to File a Registration	23
	(e) Availability of Registration and Plan.....	23
	(f) Additional Information	24
	(g) Additional Notification	24
	(h) Action by Commissioner	24
	(i) Transition to New General Permit	24
	(j) Latest Date to Submit a Registration Under this General Permit	25
Section 5.	Conditions of this General Permit	25
	(a) Conditions Applicable to Certain Discharges.....	25
	(b) Stormwater Pollution Control Plan.....	26
	(c) Monitoring	38
	(d) Reporting and Record Keeping Requirements.....	41
	(e) Regulations of Connecticut State Agencies Incorporated into this General Permit	42
	(f) Reliance on Registration	42
	(g) Duty to Correct and Report Violations	42
	(h) Duty to Provide Information.....	42
	(i) Certification of Documents.....	42
	(j) Date of Filing.....	42
	(k) False Statements	43
	(l) Correction of Inaccuracies	43
	(m) Transfer of Authorization	43
	(n) Reopener	43
	(o) Other Applicable Law.....	43
	(p) Other Rights.....	43
Section 6.	Termination Requirements.....	44
	(a) Notice of Termination.....	44

	(b) Termination Form	44
	(c) Where to File a Termination Form	45
Section 7.	Commissioner's Powers	45
	(a) Abatement of Violations	45
	(b) General Permit Revocation, Suspension, or Modification.....	45
	(c) Filing of an Individual Application.....	45
Appendix A	Endangered and Threatened Species	
Appendix B	Low Impact Development Guidance Information and Fact Sheet	
Appendix C	Aquifer Protection Guidance Information	
Appendix D	Coastal Management Act Determination Form	
Appendix E	Conservation Districts of Connecticut	
Appendix F	Memorandum of Agreement Between DEEP and Conservation Districts	
Appendix G	Historic Preservation Review	
Appendix H	Wild & Scenic Rivers Guidance	

General Permit for the Discharge of Stormwater and Dewatering Wastewaters from Construction Activities

Section 1. Authority

This general permit is issued under the authority of section 22a-430b of the Connecticut General Statutes.

Section 2. Definitions

The definitions of terms used in this general permit shall be the same as the definitions contained in section 22a-423 of the Connecticut General Statutes and section 22a-430-3(a) of the Regulations of Connecticut State Agencies. As used in this general permit, the following definitions shall apply:

“x-year, 24-hour rainfall event” means the maximum 24-hour precipitation event with a probable recurrence interval of once in the given number of years (i.e. x=2, 25 or 100), as defined by the National Weather Service in Technical Paper Number 40, “Rainfall Frequency Atlas of the United States,” May 1961, and subsequent amendments, or equivalent regional or state rainfall probability information developed therefrom.

“Annual sediment load” means the total amount of sediment carried by stormwater runoff on an annualized basis.

“Aquifer protection area” means aquifer protection area as defined in section 22a-354h of the Connecticut General Statutes.

“Best engineering practices” means the design of engineered control measures to control pollution to the maximum extent achievable using measures that are technologically available and economically practicable.

“CFR” means the Code of Federal Regulations.

“Coastal area” means coastal area as defined in section 22a-93(3) of the Connecticut General Statutes.

“Coastal waters” means coastal waters as defined in section 22a-93(5) of the Connecticut General Statutes.

“Commissioner” means commissioner as defined in section 22a-2(b) of the Connecticut General Statutes.

“Construction activity” means any activity associated with construction at a site including, but not limited to, clearing and grubbing, grading, excavation, and dewatering.

“Department” means the Department of Energy & Environmental Protection.

“Developer” means a person who or municipality which is responsible, either solely or partially through contract, for the design and construction of a project site.

“Dewatering wastewater” means wastewater associated with the construction activity generated from the lowering of the groundwater table, the pumping of accumulated stormwater or uncontaminated groundwater from an excavation, the pumping of surface water from a cofferdam, or pumping of other surface water that has been diverted into a construction site.

“District” means a soil and water conservation district established pursuant to section 22a-315 of the Connecticut General Statutes. Appendix E lists the Districts, their geographic delineations, and contact information.

“*Disturbance*” means the execution of any of the construction activity(ies) defined in this general permit.

“*Effective Impervious Cover*” is the total area of a site with a Rational Method runoff coefficient of 0.7 or greater (or other equivalent methodology) from which stormwater discharges directly to a surface water or to a storm sewer system.

“*Engineered stormwater management system*” means any control measure and related appurtenances which requires engineering analysis and/or design by a professional engineer.

“*Erosion*” means the detachment and movement of soil or rock fragments by water, wind, ice and gravity.

“*Fresh-tidal wetland*” means a tidal wetland with an average salinity level of less than 0.5 parts per thousand.

“*Grab sample*” means an individual sample collected in less than fifteen minutes.

“*Groundwater*” means those waters of the state that naturally exist or flow below the surface of the ground.

“*Guidelines*” means the 2002 Connecticut Guidelines for Soil Erosion and Sediment Control, as amended, established pursuant to section 22a-328 of the Connecticut General Statutes.

“*High Quality Waters*” means those waters defined as high quality waters in the Connecticut Water Quality Standards published by the Department, as may be amended.

“*Impaired water(s)*” means those surface waters of the state designated by the commissioner as impaired pursuant to Section 303(d) of the Clean Water Act and as identified in the most recent State of Connecticut Integrated Water Quality Report.

“*In Responsible charge*” means professional experience for which the Commissioner determines that a professional’s primary duties consistently involve a high level of responsibility and decision making in the planning and designing of engineered stormwater management systems or in the planning and designing of soil erosion and sediment controls for residential and commercial construction projects. The Commissioner shall consider the following in determining whether a professional’s experience qualifies as responsible charge experience:

- (i) the level of independent decision-making exercised;
- (ii) the number of individuals and the disciplines of the other professionals that the professional supervised or coordinated;
- (iii) the extent to which a professional’s responsibilities consistently involved the review of work performed by other professionals involved the planning and designing of engineered stormwater management systems or the planning and designing of soil erosion and sediment controls for residential and commercial construction projects;
- (iv) the extent to which a professional’s responsibilities consistently involved the planning and designing of engineered stormwater management systems or the planning and designing of soil erosion and sediment controls for residential and commercial construction projects and whether such responsibilities were an integral and substantial component of the professional’s position;
- (v) the nature of a professional’s employer’s primary business interests and the relation of those interests to planning and designing of engineered stormwater management systems or to planning and designing of soil erosion and sediment controls for residential and commercial construction projects;

- (vi) the extent to which a professional has engaged in the evaluation and selection of scientific or technical methodologies for planning and designing of engineered stormwater management systems or for planning and designing of soil erosion and sediment controls for residential and commercial construction projects;
- (vii) the extent to which a professional drew technical conclusions, made recommendations, and issued opinions based on the results of planning and designing of engineered stormwater management systems or of planning and designing of soil erosion and sediment controls for residential and commercial construction projects; or
- (viii) any other factor that the Commissioner deems relevant.

“*Individual permit*” means a permit issued to a specific permittee under section 22a-430 of the Connecticut General Statutes.

“*Inland wetland*” means wetlands as defined in section 22a-38 of the Connecticut General Statutes.

“*Landscape Architect*” means a person with a currently effective license issued in accordance with chapter 396 of the Connecticut General Statutes.

“*Linear Project*” includes the construction of roads, railways, bridges, bikeways, conduits, substructures, pipelines, sewer lines, towers, poles, cables, wires, connectors, switching, regulating and transforming equipment and associated ancillary facilities in a long, narrow area.

“*Locally approvable project*” means a construction activity for which the registration is not for a municipal, state or federal project and is required to obtain municipal approval for the project.

“*Locally exempt project*” means a construction activity for which the registration is for a project authorized under municipal, state or federal authority and may not be required to obtain municipal approval for the project.

“*Low Impact Development*” or “*LID*” means a site design strategy that maintains, mimics or replicates pre-development hydrology through the use of numerous site design principles and small-scale treatment practices distributed throughout a site to manage runoff volume and water quality at the source.

“*Minimize*”, for purposes of implementing the control measures in Section 5(b)(2) of this general permit, means to reduce and/or eliminate to the extent achievable using control measures that are technologically available and economically practicable and achievable in light of best industry practice.

“*Municipal separate storm sewer system*” or “*MS4*” means conveyances for stormwater (including roads with drainage systems, municipal streets, catch basins, curbs, gutters, ditches, man-made channels or storm drains) owned or operated by any municipality and discharging to surface waters of the state.

“*Municipality*” means a city, town or borough of the state as defined in section 22a-423 of the Connecticut General Statutes.

“*Nephelometric Turbidity Unit*” or “*NTU*” means a unit measure of turbidity from a calibrated nephelometer.

“*Normal Working Hours*”, for the purposes of monitoring under Section 5(c) of this general permit, are considered to be, at a minimum, Monday through Friday, between the hours of 8:00 am and 6:00 pm, unless additional working hours are specified by the permittee.

“*Permittee*” means any person who or municipality which initiates, creates or maintains a discharge in accordance with Section 3 of this general permit.

“*Person*” means person as defined in section 22a-423 of the Connecticut General Statutes.

“*Phase*” means a portion of a project possessing a distinct and complete set of activities that have a specific functional goal wherein the work to be completed in the phase is not dependent upon the execution of work in a later phase in order to make it functional.

“*Point Source*” means any discernible, confined and discrete stormwater conveyance (including but not limited to, any pipe, ditch, channel, tunnel, conduit, discrete fissure, container, rolling stock, concentrated animal feeding operation, landfill leachate collection system, vessel or other floating craft) from which pollutants are or may be discharged.

“*Professional Engineer*” or “*P.E.*” means a person with a currently effective license issued in accordance with chapter 391 of the Connecticut General Statutes.

“*Qualified Inspector*” means an individual possessing either (1) a professional license or certification by a professional organization recognized by the commissioner related to agronomy, civil engineering, landscape architecture, soil science, and two years of demonstrable and focused experience in erosion and sediment control plan reading, installation, inspection and/or report writing for residential and commercial construction projects in accordance with the Guidelines; or (2) five years of demonstrable and focused experience in erosion and sediment control plan reading, installation, inspection and/or report writing for residential and commercial construction projects in accordance with the Guidelines; or (3) certification by the Connecticut Department of Transportation (DOT).

“*Qualified professional engineer*” means a professional engineer who has, for a minimum of eight years, engaged in the planning and designing of engineered stormwater management systems for residential and commercial construction projects in accordance with the Guidelines and the Stormwater Quality Manual including, but not limited to, a minimum of four years in responsible charge of the planning and designing of engineered stormwater management systems for such projects.

“*Qualified soil erosion and sediment control professional*” means a landscape architect or a professional engineer who: (1) has for a minimum of eight years engaged in the planning and designing of soil erosion and sediment controls for residential and commercial construction projects in accordance with the Guidelines including, but not limited to, a minimum of four years in responsible charge of the planning and designing of soil erosion and sediment controls for such projects; or (2) is currently certified as a professional in erosion and sediment control as designated by EnviroCert International, Incorporated (or other certifying organization acceptable to the commissioner) and has for a minimum of six years experience engaged in the planning and designing of soil erosion and sediment controls for residential and commercial construction projects in accordance with the Guidelines including, but not limited to, a minimum of four years in responsible charge in the planning and designing of soil erosion and sediment controls for such projects.

“*Registrant*” means a person or municipality that files a registration.

“*Registration*” means a registration form filed with the commissioner pursuant to Section 4 of this general permit.

“*Regulated Municipal Separate Storm Sewer System*” or “*Regulated MS4*” means the separate storm sewer system of the City of Stamford or any municipally-owned or -operated separate storm sewer system (as defined above) authorized by the most recently issued General Permit for the Discharge of Stormwater from Small Municipal Separate Storm Sewer Systems (MS4 general permit) including all those located partially

or entirely within an Urbanized Area and those additional municipally-owned or municipally-operated Small MS4s located outside an Urbanized Area as may be designated by the commissioner.

“*Retain*” means to hold runoff on-site to promote vegetative uptake and groundwater recharge through the use of runoff reduction or LID practices or other measures. In addition, it means there shall be no subsequent point source release to surface waters from a storm event defined in this general permit or as approved by the commissioner.

“*Runoff reduction practices*” means those post-construction stormwater management practices used to reduce post-development runoff volume delivered to the receiving water, as defined by retaining the volume of runoff from a storm up to the first half inch or one inch of rainfall in accordance with Sections 5(b)(2)(C)(i)(a) or (b), respectively. Runoff reduction is quantified as the total annual post-development runoff volume reduced through canopy interception, soil amendments, evaporation, rainfall harvesting, engineered infiltration, extended filtration or evapo-transpiration.

“*Sediment*” means solid material, either mineral or organic, that is in suspension, is transported, or has been moved from its site of origin by erosion.

“*Site*” means geographically contiguous land on which a construction activity takes place or on which a construction activity for which authorization is sought under this general permit is proposed to take place. Non-contiguous land or water owned by the same person shall be deemed the same site if such land is part of a linear project (as defined in this section) or is otherwise connected by a right-of-way, which such person controls.

“*Soil*” means any unconsolidated mineral and organic material of any origin.

“*Stabilize*” means the use of measures as outlined in the 2002 Connecticut Guidelines for Soil Erosion and Sediment Control, as amended, or as approved by the commissioner, to prevent the visible movement of soil particles and development of rills.

“*Structural measure*” means a measure constructed for the temporary storage and/or treatment of stormwater runoff.

“*Standard Industrial Classification Code*” or “*SIC Code*” means those codes provided in the Standard Industrial Classification Manual, Executive Office of the President, Office of Management and Budget 1987.

“*Standard of care*”, as used in Section 3(b), means to endeavor to perform in a manner consistent with that degree of care and skill ordinarily exercised by members of the same profession currently practicing under similar circumstances.

“*Stormwater*” means waters consisting of rainfall runoff, including snow or ice melt during a rain event.

“*Stormwater Quality Manual*” means the 2004 Connecticut Stormwater Quality Manual published by the Connecticut Department of Energy & Environmental Protection, as amended.

“*Surface water*” means that portion of waters, as the term “waters” is defined in section 22a-423 of the Connecticut General Statutes, located above the ground surface.

“*Tidal wetland*” means a wetland as that term is defined in section 22a-29(2) of the Connecticut General Statutes.

“*Total disturbance*” means the total area on a site where soil will be exposed or susceptible to erosion during the course of all phases of a project.

“*Total Maximum Daily Load*” or “*TMDL*” means the maximum capacity of a surface water to assimilate a pollutant as established by the commissioner, including pollutants contributed by point and non-point sources and a margin of safety.

“*Upland soils*” means soils which are not designated as poorly drained, very poorly drained, alluvial, or flood plain by the National Cooperative Soils Survey, as may be amended, of the Natural Resources Conservation Service of the United States Department of Agriculture and/or the inland wetlands agency of the municipality in which the project will take place.

“*Water company*” means water company as defined in section 25-32a of the Connecticut General Statutes.

“*Water Quality Standards or Classifications*” means those water quality standards or classifications contained in the Connecticut Water Quality Standards published by the Department, as may be amended.

“*Water Quality Volume*” or “*WQV*” means the volume of runoff generated by one inch of rainfall on a site as defined in the 2004 Connecticut Stormwater Quality Manual, as amended.

Section 3. Authorization Under This General Permit

(a) *Eligible Activities*

This general permit authorizes the discharge of stormwater and dewatering wastewaters to surface waters from construction activities on a site, as defined in this general permit, with a total disturbance of one or more acres of land area on a site, *regardless of project phasing*.

In the case of a larger plan of development (such as a subdivision), the estimate of total acres of site disturbance shall include, but is not limited to, road and utility construction, individual lot construction (e.g. house, driveway, septic system, etc.), and all other construction associated with the overall plan, regardless of the individual parties responsible for construction of these various elements.

(b) *Requirements for Authorization*

This general permit authorizes the construction activity listed in the “Eligible Activities” section (Section 3(a)) of this general permit provided:

(1) Coastal Management Act

Such construction activity must be consistent with all applicable goals and policies in section 22a-92 of the Connecticut General Statutes, and must not cause adverse impacts to coastal resources as defined in section 22a-93(15) of the Connecticut General Statutes. Please refer to the Appendix D for additional guidance.

(2) Endangered and Threatened Species

Such activity must not threaten the continued existence of any species listed pursuant to section 26-306 of the Connecticut General Statutes as endangered or threatened and must not result in the destruction or adverse modification of habitat designated as essential to such species. See Appendix A.

(3) Aquifer Protection Areas

Such construction activity, if it is located within an aquifer protection area as mapped under section 22a-354b of the General Statutes, must comply with regulations adopted pursuant to section 22a-354i of the General Statutes. Please refer to the Appendix C for additional guidance.

For any construction activity regulated pursuant to sections 8(c) and 9(b) of the Aquifer Protection Regulations (section 22a-354i(1)-(10) of the Regulations of Connecticut State Agencies), the Stormwater Pollution Control Plan (Plan) must assure that stormwater run-off generated from the regulated construction activity (i) is managed in a manner so as to prevent pollution of groundwater, and (ii) complies with all the requirements of this general permit.

(4) Mining Operations Exception

The stormwater discharge resulting from an activity classified as Standard Industrial Classification 10 through 14 (the mining industry) is not authorized by this general permit and is regulated under the most recently issued General Permit for the Discharge of Stormwater Associated with Industrial Activity.

(5) Discharge to POTW

The stormwater is *not* discharged to a Publicly Owned Treatment Works (POTW).

(6) Discharge to Groundwater

The stormwater is *not* discharged entirely to groundwater, meaning a stormwater discharge to a surface water will not occur up to a 100-year, 24-hour rainfall event.

(7) Such construction activity must be consistent with the Wild and Scenic Rivers Act (16 U.S.C. 1271-1287) for those river components and tributaries which have been designated as Wild and Scenic by the United States Congress. Further, such construction activities must not have a direct and adverse effect on the values for which such river designation was established. Please refer to Appendix H for additional guidance.

(8) Certification Requirements for Registrants and other Individuals

As part of the registration for this general permit, the registrant and any other individual or individuals responsible for preparing the registration submits to the commissioner a written certification which, at a minimum, complies with the following requirements:

(A) The registrant and any other individual or individuals responsible for preparing the registration and signing the certification has completely and thoroughly reviewed, at a minimum, this general permit and the following regarding the activities to be authorized under such general permit:

- (i) all registration information provided in accordance with Section 4(c)(2) of such general permit;
- (ii) the project site, based on a site inspection;
- (iii) the Stormwater Pollution Control Plan; and
- (iv) any plans and specifications and any Department approvals regarding such Stormwater Pollution Control Plan;

- (B) The registrant and any other individual or individuals responsible for preparing the registration and signing the certification pursuant to this general permit has, based on the review described in section 3(b)(8)(A) of this general permit, made an affirmative determination to:
- (i) comply with the terms and conditions of this general permit;
 - (ii) maintain compliance with all plans and documents prepared pursuant to this general permit including, but not limited to, the Stormwater Pollution Control Plan;
 - (iii) properly implement and maintain the elements of the Stormwater Pollution Control Plan; and
 - (iv) properly operate and maintain all stormwater management systems in compliance with the terms and conditions of this general permit to protect the waters of the state from pollution;
- (C) Such registrant and any other individual or individuals responsible for preparing the registration certifies to the following statement: "I hereby certify that I am making this certification in connection with a registration under such general permit, submitted to the commissioner by [INSERT NAME OF REGISTRANT] for an activity located at [INSERT ADDRESS OF PROJECT OR ACTIVITY] and that all terms and conditions of the general permit are being met for all discharges which have been initiated and such activity is eligible for authorization under such permit. I further certify that a system is in place to ensure that all terms and conditions of this general permit will continue to be met for all discharges authorized by this general permit at the site. I certify that the registration filed pursuant to this general permit is on complete and accurate forms as prescribed by the commissioner without alteration of their text. I certify that I have personally examined and am familiar with the information that provides the basis for this certification, including but not limited to all information described in Section 3(b)(8)(A) of such general permit, and I certify, based on reasonable investigation, including my inquiry of those individuals responsible for obtaining such information, that the information upon which this certification is based is true, accurate and complete to the best of my knowledge and belief. I certify that I have made an affirmative determination in accordance with Section 3(b)(8)(B) of this general permit. I understand that the registration filed in connection with such general permit is submitted in accordance with and shall comply with the requirements of Section 22a-430b of Connecticut General Statutes. I also understand that knowingly making any false statement made in the submitted information and in this certification may be punishable as a criminal offense, including the possibility of fine and imprisonment, under section 53a-157b of the Connecticut General Statutes and any other applicable law."
- (9) The registrant has submitted to the commissioner a written certification by a professional engineer or, where appropriate, a landscape architect licensed in the State of Connecticut for the preparation, planning and design of the Stormwater Pollution Control Plan and stormwater management systems:
- (A) The professional engineer or landscape architect shall certify to the following statement:
- "I hereby certify that I am a [professional engineer][landscape architect] licensed in the State of Connecticut. I am making this certification in connection with a registration under such general permit, submitted to the commissioner by [INSERT NAME OF REGISTRANT] for an activity located at [INSERT ADDRESS OF PROJECT OR ACTIVITY]. I certify that I have thoroughly and completely reviewed the Stormwater

Pollution Control Plan for the project or activity covered by this certification. I further certify, based on such review and on the standard of care for such projects, that the Stormwater Pollution Control Plan has been prepared in accordance with the Connecticut Guidelines for Soil Erosion and Sediment Control, as amended, the Stormwater Quality Manual, as amended, and the conditions of the general permit, and that the controls required for such Plan are appropriate for the site. I further certify, based on reasonable investigation, including my inquiry of those individuals responsible for obtaining such information, that the information upon which this certification is based is true, accurate and complete to the best of my knowledge and belief. I also understand that knowingly making any false statement in this certification may subject me to sanction by the Department and/or be punishable as a criminal offense, including the possibility of fine and imprisonment, under section 53a-157b of the Connecticut General Statutes and any other applicable law."

- (B) Nothing in this section shall be construed to authorize a professional engineer or a landscape architect to engage in any profession or occupation requiring a license under any other provision of the general statutes without such license.

(10) Plan Review and Certification by a District for Locally Approvable Projects

For those Plans not reviewed in accordance with Section 3(b)(11), below, the registrant has submitted to the commissioner a written certification by the appropriate regional District for the review of the Stormwater Pollution Control Plan pursuant to Appendix F, which, at a minimum, complies with the following requirements:

- (A) the Plan Review Certification must be signed by the District. Information on the District review process is outlined in the Memorandum of Agreement provided in Appendix F. In cases where the District is unable to complete review of the Plan within the time limits specified in the Memorandum of Agreement in Appendix F, a notice to that effect signed by the District may be submitted in lieu of the certification.
- (B) the Stormwater Pollution Control Plan has been prepared in accordance with the requirements of Section 5(b) of the general permit.
- (C) Nothing in this subsection shall be construed to authorize District personnel to engage in any profession or occupation requiring a license under any other provision of the general statutes without such license.

(11) Plan Review and Certification by a Qualified Soil Erosion and Sediment Control Professional and Qualified Professional Engineer for Locally Approvable Projects

For those Plans not reviewed in accordance with Section 3(b)(10), above, the registrant has submitted to the commissioner a written certification by a qualified professional engineer or a qualified soil erosion and sediment control professional in accordance with the following requirements:

- (A) for projects disturbing more than one acre and less than fifteen (15) acres, such qualified soil erosion and sediment control professional or qualified professional engineer:
 - (i) is not an employee, as defined by the Internal Revenue Service in the Internal Revenue Code of 1986, of the registrant; and
 - (ii) has no ownership interest of any kind in the project for which the registration is being submitted.

- (B) for projects disturbing fifteen (15) acres or more, such qualified soil erosion and sediment control professional or qualified professional engineer:
 - (i) is not an employee, as defined by the Internal Revenue Service in the Internal Revenue Code of 1986, of the registrant;
 - (ii) did not engage in any activities associated with the preparation, planning, designing or engineering of such plan for soil erosion and sediment control or plan for stormwater management systems on behalf of such registrant;
 - (iii) is not under the same employ as any person who engaged in any activities associated with the preparation, planning, designing or engineering of such plans and specifications for soil erosion and sediment control or plans and specifications for stormwater management systems on behalf of such registrant; and
 - (iv) has no ownership interest of any kind in the project for which the registration is being submitted.
- (C) The qualified professional engineer or qualified soil erosion and sediment control professional signing the certification has, at a minimum, completely and thoroughly reviewed this general permit and the following regarding the discharges to be authorized under such general permit:
 - (i) all registration information provided in accordance with Section 4(c)(2) of such general permit;
 - (ii) the site, based on a site inspection;
 - (iii) the Stormwater Pollution Control Plan;
 - (iv) the Guidelines;
 - (v) the Stormwater Quality Manual, if applicable; and
 - (vi) all non-engineered and engineered stormwater management systems, including any plans and specifications and any Department approvals regarding such stormwater management systems.
- (D) Affirmative Determination
 - (i) The qualified soil erosion and sediment control professional signing the certification must have made an affirmative determination, based on the review described in section 3(b)(11)(C) of this general permit that:
 - (a) the Stormwater Pollution Control Plan prepared and certified pursuant to the registration is adequate to assure that the project or activity authorized under this general permit, if implemented in accordance with the Stormwater Pollution Control Plan, will comply with the terms and conditions of such general permit; and
 - (b) all non-engineered stormwater management systems:
 - (I) have been designed to control pollution to the maximum extent achievable using measures that are technologically available and economically

practicable and that conform to those in the Guidelines and the Stormwater Quality Manual;

- (2) will function properly as designed;
- (3) are adequate to ensure compliance with the terms and conditions of this general permit; and
- (4) will protect the waters of the state from pollution.

(ii) The qualified professional engineer signing the certification must have made an affirmative determination, based on the review described in section 3(b)(11)(C) of this general permit that:

- (a) the Stormwater Pollution Control Plan prepared and certified pursuant to the registration is adequate to assure that the activity authorized under this general permit, if implemented in accordance with the Stormwater Pollution Control Plan, will comply with the terms and conditions of such general permit; and
- (b) all non-engineered and engineered stormwater management systems:
 - (1) have been designed to control pollution to the maximum extent achievable using measures that are technologically available and economically practicable and that conform to those in the Guidelines and the Stormwater Quality Manual;
 - (2) will function properly as designed;
 - (3) are adequate to ensure compliance with the terms and conditions of this general permit; and
 - (4) will protect the waters of the state from pollution.

(E) The qualified professional engineer or qualified soil erosion and sediment control professional shall, provided it is true and accurate, certify to the following statement:

"I hereby certify that I am a qualified professional engineer or qualified soil erosion and sediment control professional, or both, as defined in the General Permit for Discharge of Stormwater and Dewatering Wastewaters from Construction Activities and as further specified in sections 3(b)(11)(A) and (B) of such general permit. I am making this certification in connection with a registration under such general permit, submitted to the commissioner by [INSERT NAME OF REGISTRANT] for an activity located at [INSERT ADDRESS OF PROJECT OR ACTIVITY]. I have personally examined and am familiar with the information that provides the basis for this certification, including but not limited to all information described in Section 3(b)(11)(C) of such general permit, and I certify, based on reasonable investigation, including my inquiry of those individuals responsible for obtaining such information, that the information upon which this certification is based is true, accurate and complete to the best of my knowledge and belief. I further certify that I have made the affirmative determination in accordance with Sections 3(b)(11)(D)(i) and (ii) of this general permit. I understand that this certification is part of a registration submitted in accordance with Section 22a-430b of Connecticut General Statutes and is subject to the requirements and responsibilities for a qualified professional in such statute. I also understand that knowingly making any false statement in this certification may be

punishable as a criminal offense, including the possibility of fine and imprisonment, under section 53a-157b of the Connecticut General Statutes and any other applicable law."

- (F) Nothing in this subsection shall be construed to authorize a qualified soil erosion and sediment control professional or a qualified professional engineer to engage in any profession or occupation requiring a license under any other provision of the general statutes without such license.

(12) New Discharges to Impaired Waters

New stormwater discharges directly to an impaired water, as indicated in the State's Integrated Water Quality Report, must be in accordance with the following conditions:

- (A) Stormwater discharges that go directly to impaired waters seeking authorization under this general permit shall comply with the requirements of this subsection (B) below if the indicated cause or potential cause of the impairment is one of the following:
- Site Clearance (Land Development or Redevelopment)
 - Post-Development Erosion and Sedimentation
 - Source Unknown (if cause of impairment is Sedimentation/Siltation)
- (B) Such stormwater discharge is authorized if the permittee complies with the requirements of Section 5(b)(3) of this permit and receives a written affirmative determination from the commissioner that the discharge meets the requirements of that section. In such case, the permittee must keep a copy of the written determination onsite with the Plan. If the permittee does not receive such affirmative determination, the construction activity is not authorized by this general permit and must obtain an individual permit.

(c) Registration

Pursuant to the "Registration Requirements" section (Section 4) of this general permit, a completed registration with respect to the construction activity shall be filed with the commissioner as follows:

(1) Locally Approvable Projects

The registration must:

- (A) Be electronically submitted, along with all required elements in subsections (B), (C) and (D), below, at least sixty (60) days prior to the planned commencement of the construction activity.
- (B) Include the Registration Form (available at www.ct.gov/deep/stormwater).
- (C) Include any additional forms and information regarding compliance and/or consistency with the Coastal Management Act, Impaired Waters (including TMDL requirements), Endangered and Threatened Species, and Aquifer Protection Areas that may be required pursuant to the "Requirements of Authorization" section (Section 3(b)).
- (D) Include a Plan Review Certification in accordance with the "Plan Review Certification" (Section 5(b)(8)).

Locally Approvable projects may also choose to make their Plan electronically available in accordance with Section 4(c)(2)(N) of this general permit. The 60 day period cited in subsection

(A), above, will not begin until all required elements have been submitted. Failure to include any of these required submissions shall be grounds to reject the registration.

(2) Locally Exempt Projects

The registration must:

- (A) Be electronically submitted, along with all required elements in subsections (B), (C) and (D), below, at least:
- (i) sixty (60) days prior to the planned commencement of the construction activity if the site has a total disturbed area of between one (1) and twenty (20) acres; *or*
 - (ii) ninety (90) days prior to the planned commencement of construction activity if the site:
 - (a) has a total disturbed area greater than twenty (20) acres;
 - (b) discharges to a tidal wetland (that is not a fresh-tidal wetland) within 500 feet of the discharge point; *or*
 - (c) is subject to the impaired waters provisions of Section 3(b)(12).
- (B) Include the Registration Form (available at www.ct.gov/deep/stormwater).
- (C) Include any additional forms and information regarding compliance and/or consistency with the Coastal Management Act, Impaired Waters (including TMDL requirements), Endangered and Threatened Species, and Aquifer Protection that may be required pursuant to the “Requirements of Authorization” section (Section 3(b)).
- (D) Include an electronic copy of the Stormwater Pollution Control Plan (Plan) (or a web address where the electronic Plan can be downloaded) for the commissioner’s review. The electronic Plan shall be in Adobe™ PDF format or similar publicly available format in common use. **DO NOT INCLUDE** in this electronic copy any pages or other material that do not pertain to stormwater management or erosion and sedimentation control (such as electrical and lighting plans, boundary or lot surveys, building plans, non-stormwater related detail sheets, etc.).

The 60 or 90 day periods cited in subsections (A), above, will not begin until all required elements have been submitted. Failure to include any of these required submissions shall be grounds to reject the registration.

(3) Re-Registration of Existing Projects

For sites previously registered under any previous version of the General Permit for the Discharge of Stormwater and Dewatering Wastewaters from Construction Activities and for which no Notice of Termination has been submitted pursuant to the “Termination Requirements” section (Section 6), a Re-Registration Form (available at www.ct.gov/deep/stormwater) pursuant to Section 4(c)(3) shall be submitted on or before February 1, 2014. The re-registration fee is payable (or waived) in accordance with Section 4(c)(1)(A)(iii). Resubmission of the permittee’s Plan is not required unless specifically requested by the commissioner.

(d) *Small Construction*

For construction projects with a total disturbance of between one and five acres, the permittee shall adhere to the erosion and sediment control land use regulations of the municipality in which the construction activity is conducted, as well as the Guidelines and the Stormwater Quality Manual.

No registration or Plan review and certification shall be required for such construction activity provided a land-use commission of the municipality (i.e. planning/zoning, wetland, conservation, etc) reviews and issues a written approval of the proposed erosion and sediment control measures, pursuant to the requirements of section 22a-329 of the Connecticut General Statutes. In the absence of such municipal commission approval, the permittee shall register with the DEEP under the requirements for a Locally Exempt Project and comply with all applicable conditions of this general permit.

(e) *Geographic Area*

This general permit applies throughout the State of Connecticut.

(f) *Effective Date and Expiration Date of this General Permit*

The registration provisions of Section 3(c) and 4 of this General Permit, including any applicable definitions or provisions referred to in those sections insofar as they facilitate submission of a registration, shall be effective September 1, 2013. All remaining provisions of this General Permit shall be effective on October 1, 2013. The provisions of this General Permit shall expire on September 30, 2018.

(g) *Effective Date of Authorization*

A construction activity is authorized by this general permit at such time as specified in subsections (1) and (2), below.

(1) Authorization Timelines

The activity is authorized based on the following timelines unless superseded by subsection (2), below:

- (A) for locally approvable projects, sixty (60) days after the submission of the registration form required by Section 4(c), or
- (B) for locally exempt projects under 20 acres, sixty (60) days after the submission of the registration form required by Section 4(c), or
- (C) for locally exempt projects over 20 acres, ninety (90) days after the submission of the registration form required by Section 4(c).

(2) Alternate Authorization Timelines

If one of the following conditions for authorization applies, that condition shall supersede those of subsection (1), above:

- (A) for sites for which the registration and Plan availability and review provisions of Section 4(e) are completed prior to the authorization periods in subsection (1), above, the commissioner may authorize the activity upon such completion, or

- (B) for sites subject to the conditions of Section 3(b)(2), 3(b)(12) and/or Section 5(a)(2), the activity is authorized on the date of the commissioner's affirmative determination and/or approval, or
- (C) for sites authorized by any previous version of this general permit and for which no Notice of Termination has been submitted pursuant to the "Termination Requirements" section (Section 6), the activity is authorized effective October 1, 2013. Authorization under this general permit shall cease if a re-registration form is not submitted on or before February 1, 2014.

(h) *Revocation of an Individual Permit*

If a construction activity is eligible for authorization under this general permit and such activity is presently authorized by an individual permit, the existing individual permit may be revoked by the commissioner upon a written request by the permittee. If the commissioner revokes such individual permit in writing, such revocation shall take effect on the effective date of authorization of such activity under this general permit.

(i) *Issuance of an Individual Permit*

If the commissioner issues an individual permit under section 22a-430 of the Connecticut General Statutes, authorizing a construction activity authorized by this general permit, this general permit shall cease to authorize that activity beginning on the date such individual permit is issued.

Section 4. Registration Requirements

(a) *Who Must File a Registration*

With the exception noted in the "Small Construction" section (Section 3(d)) of this general permit, any person or municipality which initiates, creates, originates or maintains a discharge described in the "Eligible Activities" section (Section 3(a)) of this general permit shall file with the commissioner a registration form that meets the requirements of the "Contents of Registration" section (Section 4(c)) of this general permit (or a re-registration form) and the applicable fee within the timeframes and in the amounts specified in Sections 3(c) and 4(c)(1)(A), respectively. Any such person or municipality filing a registration remains responsible for maintaining compliance with this general permit.

(b) *Scope of Registration*

Each registration shall be limited to the discharge at or from one site; no registration shall cover discharges at or from more than one site.

(c) *Contents of Registration*

(1) Fees

(A) Registration Fee

A registration, if required, shall not be deemed complete unless the registration fee has been paid in full.

(i) Locally Approvable Projects

A registration fee of \$625.00 shall be submitted to the Department with the registration form.

(ii) Locally Exempt Projects

A registration fee shall be submitted with a registration form as follows:

- (a) For sites with total disturbance of between one (1) and twenty (20) acres, the fee shall be \$3,000.
- (b) For sites with total disturbance equal to or greater than twenty (20) acres and less than fifty (50) acres, the fee shall be \$4,000.
- (c) For sites with total disturbance equal to or greater than fifty (50) acres, the fee shall be \$5,000.

The fees for municipalities shall be half of those indicated in subsections (a), (b) and (c) above pursuant to section 22a-6(b) of the Connecticut General Statutes. State and Federal agencies shall pay the full fees specified in this subsection.

(iii) Re-registration

- (a) For sites that registered under the previous version of the General Permit for the Discharge of Stormwater and Dewatering Wastewaters from Construction Activities prior to September 1, 2012 and for which no Notice of Termination has been submitted pursuant to the "Termination Requirements" section (Section 6), the re-registration fee shall be \$625 payable with submission of the re-registration form within one hundred twenty (120) days from the effective date of this general permit. If a Notice of Termination is submitted prior to that time, no registration or fee are required.
- (b) For sites that registered under the previous version of the General Permit for the Discharge of Stormwater and Dewatering Wastewaters from Construction Activities on or after September 1, 2012 and for which no Notice of Termination has been submitted pursuant to the "Termination Requirements" section (Section 6), the re-registration fee is waived.

(B) The registration fee shall be paid electronically or by check or money order payable to the Department of Energy & Environmental Protection.

(C) The registration fee is non-refundable.

(2) Registration Form

A registration shall be filed electronically on forms prescribed and provided by the commissioner (available at: www.ct.gov/deep/stormwater) and shall include, but not be limited to, the following:

- (A) Legal name, address, and telephone number of the registrant. If the registrant is a person (as defined in Section 2 of this permit) transacting business in Connecticut and is registered with the Connecticut Secretary of the State, provide the exact name as registered with the Connecticut Secretary of the State.
- (B) Legal name, address and telephone number of the owner of the property on which the construction activity will take place.

- (C) Legal name, address and telephone number of the primary contact for departmental correspondence and inquiries, if different from the registrant.
- (D) Legal name, address and telephone number of the developer of the property on which the construction activity is to take place.
- (E) Legal name, address and daytime and off-hours telephone numbers of the general contractor(s) or other representative(s), if different from the developer.
- (F) Legal name, address and telephone number of any consultant(s), engineer(s) or landscape architect(s) retained by the permittee to prepare the registration and Stormwater Pollution Control Plan.
- (G) Location address or description of the site for which the registration is filed.
- (H) The estimated duration of the construction activity.
- (I) Indication of the normal working hours of the site.
- (J) A brief description of the construction activity, including, but not limited to:
 - (i) Total number of acres to be disturbed, regardless of phasing.
 - (ii) Assurance that construction is in accordance with the Guidelines and local erosion and sediment control ordinances, where applicable.
 - (iii) For sites in the Coastal Boundary, documentation that the DEEP Office of Long Island Sound Programs or local governing authority has issued a coastal site plan approval or a determination that the project is exempt from coastal site plan review (see Appendix D) in accordance with section 22a-92 and 22a-93(15) of the Connecticut General Statutes.
 - (iv) Documentation that the construction activity will not threaten the continued existence of any species listed pursuant to section 26-306 of the Connecticut General Statutes as endangered or threatened and will not result in the destruction or adverse modification of habitat designated as essential to such species (see Appendix A).
 - (v) For sites discharging to certain impaired waters, as specified in Section 3(b)(12), documentation that the construction activity meets the requirements of that section and Section 5(b)(3) for authorization under this general permit.
 - (vi) Assurance that the construction activity is not located within an aquifer protection area (see Appendix C) as mapped under section 22a-354b of the Connecticut General Statutes or, if it is located within an aquifer protection area, that the construction activity will comply with regulations adopted pursuant to section 22a-354i of the Connecticut General Statutes.
 - (vii) For a proposed locally approvable project, a plan review certification from the appropriate District, qualified soil erosion and sediment control professional, and/or qualified professional engineer in accordance with Section 5(b)(10) or (11) or a notice from the District that they were unable to complete the Plan review within the time limits specified in the Memorandum of Agreement in Appendix F.

- (K) A brief description of the stormwater discharge, including:
- (i) The name of the municipal separate storm sewer system or immediate surface water body or wetland to which the stormwater runoff will discharge;
 - (ii) Verification of whether or not the site discharges to a tidal wetland (that is not a fresh-tidal wetland) within 500 feet of the discharge point, to a high quality water or to an impaired water with or without a TMDL;
 - (iii) The name of the watershed or nearest waterbody to which the site discharges.
 - (iv) Location of the stormwater discharge(s) including latitude and longitude.
- (L) The total effective impervious cover for the site before and after the proposed construction activity.
- (M) Documentation that the proposed construction activity has been reviewed for consistency with state Historic Preservation statutes, regulations, and policies including identification of any potential impacts on property listed or eligible for listing on the Connecticut Register of Historic Places. A review conducted for an Army Corps of Engineers Section 404 wetland permit would meet this qualification. Refer to Appendix G for guidance on conducting the required review.
- (N) Registrants for locally approvable projects may, if they choose, attach an electronic copy of their Plan to their registration or provide a web address where their Plan may be downloaded. If an electronic plan is not provided, the registrant is still subject to the requirements for submission of a Plan to the commissioner or a member of the public pursuant to the "Plan Availability" section (Section 4(e)(2)). An electronic Plan shall be in Adobe™ PDF format or similar publicly available format in common use. **DO NOT INCLUDE** in the Plan any pages or other material that do not pertain to stormwater management or erosion and sedimentation control (such as electrical and lighting plans, boundary or lot surveys, building plans, non-stormwater related detail sheets, etc.).
- (O) Registrants for all locally exempt projects must submit an electronic copy of their Plan or a web address where the electronic Plan can be downloaded. The electronic Plan shall be in Adobe™ PDF format or similar publicly available format in common use. **DO NOT INCLUDE** in this Plan any pages or other material that do not pertain to stormwater management or erosion and sedimentation control (such as electrical and lighting plans, boundary or lot surveys, building plans, non-stormwater related detail sheets, etc.).
- (P) The certification of the registrant and of the individual or individuals responsible for actually preparing the registration, in accordance with Section 3(b)(8).
- (Q) For all registrations, a design certification must be signed by a professional engineer in accordance with Section 3(b)(9):.
- (R) For registrations for locally approvable projects a review certification must be signed by either: (i) a District in accordance with Section 3(b)(10), or (ii) a qualified soil erosion and sediment control professional and/or qualified professional engineer in accordance with either Section 3(b)(11).

If the registrant is not capable of submitting electronically, a paper form may be submitted in accordance with Section 4(d).

(3) Re-Registration Form

For sites previously registered under any previous version of the General Permit for the Discharge of Stormwater and Dewatering Wastewaters from Construction Activities and for which no Notice of Termination has been submitted pursuant to the “Termination Requirements” section (Section 6), a re-registration shall be filed electronically pursuant to Sections 3(c)(3) and 3(g) on forms prescribed and provided by the commissioner (available at: www.ct.gov/deep/stormwater) and shall include, but not be limited to, the following:

- (A) Legal name, address, and telephone number of the registrant. If the registrant is a person (as defined in Section 2 of this permit) transacting business in Connecticut and is registered with the Connecticut Secretary of the State, provide the exact name as registered with the Connecticut Secretary of the State.
- (B) The previously issued permit number (beginning with GSN).
- (C) Legal name, address and telephone number of the owner of the property on which the construction activity will take place.
- (D) Legal name, address and telephone number of the primary contact for departmental correspondence and inquiries, if different from the registrant.
- (E) Legal name, address and telephone number of the developer of the property on which the subject construction activity is to take place.
- (F) Legal name, address and daytime and off-hours telephone numbers of the general contractor(s) or other representative(s), if different from the developer.
- (G) Legal name, address and telephone number of any consultant(s) or engineer(s) retained by the permittee to prepare the registration and Stormwater Pollution Control Plan.
- (H) Location address or description of the site for which the re-registration is filed.
- (I) Indication of the normal working hours of the site.
- (J) The estimated duration of the construction activity.
- (K) The signature of the registrant and of the individual or individuals responsible for actually preparing the re-registration, each of who shall certify in writing as follows:

“I hereby certify that I am making this certification in connection with a registration under the General Permit for the Discharge of Stormwater and Dewatering Wastewaters from Construction Activities, submitted to the commissioner by [INSERT NAME OF REGISTRANT] for an activity located at [INSERT ADDRESS OF PROJECT OR ACTIVITY] and that all terms and conditions of the general permit are being met for all discharges which have been initiated and such activity is eligible for authorization under such permit. I further certify that all designs and plans for such activity meet the current terms and conditions of the general permit in accordance with Section 5(b)(5)(C) of such general permit and that a system is in place to ensure that all terms and conditions of this general permit will continue to be met for all discharges authorized by this general permit at the site. I certify that the registration filed pursuant to this general permit is on complete and accurate forms as prescribed by the commissioner without alteration of their text. I certify that I have personally examined and am familiar with the information that provides the basis for this certification, including but not limited to all information described in Section

3(b)(8)(A) of such general permit, and I certify, based on reasonable investigation, including my inquiry of those individuals responsible for obtaining such information, that the information upon which this certification is based is true, accurate and complete to the best of my knowledge and belief. I also understand that knowingly making any false statement made in the submitted information and in this certification may be punishable as a criminal offense, including the possibility of fine and imprisonment, under section 53a-157b of the Connecticut General Statutes and any other applicable law.”

If the registrant is not capable of submitting electronically, a paper form may be submitted in accordance with Section 4(d).

(d) *Where to File a Registration*

A registration (available at: www.ct.gov/deep/stormwater) shall be filed electronically with the commissioner in accordance with Section 3(c)(2) or (3). If the registrant does not have the capability to submit electronically, a paper registration may be filed at the following address:

CENTRAL PERMIT PROCESSING UNIT
DEPARTMENT OF ENERGY & ENVIRONMENTAL PROTECTION
79 ELM STREET
HARTFORD, CT 06106-5127

(e) *Availability of Registration and Plan*

By the fifteenth (15th) day of each month, the commissioner shall post on the DEEP website a list of registrations submitted in the previous month.

(1) Registration Availability

On or before fifteen (15) days from the date of posting by the commissioner, members of the public may review and comment on a registration. Any electronically available Plans will be posted with the corresponding registration.

(2) Plan Availability

(A) Electronic Plan Availability

For an electronically available Plan, on or before fifteen (15) days from the date of posting by the commissioner, members of the public may review and comment on a registrant’s Plan.

(B) Non-Electronic Plan Availability

For any Plan that is not electronically available, on or before fifteen (15) days from the date of a registration posting by the commissioner, members of the public may submit a written request to the commissioner to obtain a copy of a registrant’s Plan. The commissioner shall inform the registrant of the request and the name of the requesting party. If the commissioner does not already have access to a copy of the requested Plan, the registrant shall submit a copy of their Plan to the commissioner within seven (7) days of their receipt of such request. On or before fifteen (15) days from the date the commissioner makes a Plan available to the requesting party, they may submit written comments on the Plan to the commissioner.

(f) Additional Information

The commissioner may require a permittee to submit additional information that the commissioner reasonably deems necessary to evaluate the consistency of the subject construction activity with the requirements for authorization under this general permit.

(g) Additional Notification

For discharges authorized by this general permit to a regulated municipal separate storm sewer system, a copy of the registration and all attachments thereto shall also be submitted to the owner and operator of that system.

For discharges authorized by this general permit to a DOT separate storm sewer system, a copy of the registration and all attachments thereto shall also be submitted to the DOT upon request.

For discharges within a public drinking water supply watershed or aquifer area, a copy of the registration and the Plan described in subsection 5(b) of this general permit shall be submitted to the water company.

For discharges to river components and tributaries which have been designated as Wild and Scenic under the Wild and Scenic Rivers Act, a copy of the registration and the Plan described in 5(b) of this general permit shall be submitted to the applicable Wild and Scenic Coordinating Committee. Please refer to Appendix H for additional guidance

In addition, a copy of this registration and the Plan shall be available upon request to the local inland wetlands agency established pursuant to section 22a-42 of the Connecticut General Statutes, or its duly authorized agent.

(h) Action by Commissioner

- (1) The commissioner may reject without prejudice a registration if it does not satisfy the requirements of the “Contents of Registration” section (subsection 4(c)) of this general permit. Any registration refiled after such a rejection shall be accompanied by the fee specified in the “Fees” subsection (subsection 4(c)(1)) of this general permit.
- (2) The commissioner may disapprove a registration if is inconsistent with the requirements for authorization under the “Requirements for Registration” section (Section 3(b)) of this general permit, or for any other reason provided by law.
- (3) Disapproval of a registration under this subsection shall constitute notice to the registrant that the subject construction activity must be authorized under an individual permit.
- (4) Rejection or disapproval of a registration shall be in writing.

(i) Transition to New General Permit

On or after August 1, 2013, up until and including August 31, 2013, a person filing a new registration for a site may file such registration: (a) under the General Permit for the Discharge of Stormwater and Dewatering Wastewaters from Construction Activities that expires on September 30, 2013; or (b) this general permit. A person filing a new registration for a site shall not register under both the General Permit for the Discharge of Stormwater and Dewatering Wastewaters from Construction Activities that expires on September 30, 2013 and this general permit. After August 31, 2013, a person filing a new registration for a site shall only register under this general permit and shall be authorized pursuant to Section 3(g) of this general permit.

(Note: Any person who, on or after August 1, 2013, up until and including August 31, 2013, files a new registration for a site under the General Permit for the Discharge of Stormwater and Dewatering Wastewaters from Construction Activities that expires on September 30, 2013 shall, after October 1, 2013, re-register such site pursuant to Section 3(c)(3) and Section 4(c)(3) of this general permit.)

A person re-registering a site pursuant to Section 3(c)(3) and Section 4(c)(3) of this general permit may submit the required re-registration information anytime on or after August 1, 2013.

(j) *Latest Date to Submit a Registration Under this General Permit*

No person shall submit a registration under this general permit after June 30, 2018.

Section 5. Conditions of this General Permit

The permittee shall meet all requirements of this general permit at all times. In addition, a permittee shall be responsible for conducting authorized construction activities in accordance with the following conditions:

(a) *Conditions Applicable to Certain Discharges*

(1) Structures and Dredging in Coastal and Tidal Areas

Any person who or municipality that discharges stormwater into coastal tidal waters for which a permit is required under section 22a-361 of the Connecticut General Statutes (structures and dredging) or section 22a-32 of the Connecticut General Statutes (Tidal Wetlands Act), shall obtain such permit(s) from the commissioner. A tidal wetland permit is required for the placement of any sediment upon a tidal wetland, whether it is deposited directly or indirectly.

(2) Discharges to Tidal Wetlands

Any site which has a post-construction stormwater discharge to a tidal wetland (that is not a fresh-tidal wetland) where such discharge is within 500 feet of the tidal wetland, shall discharge such stormwater through a system designed to retain and infiltrate the volume of stormwater runoff generated by 1 inch of rainfall on the site. If there are site constraints that would prevent retention of this volume on-site (e.g., brownfields, capped landfills, bedrock, elevated groundwater, etc.), documentation must be submitted, for the commissioner's review and written approval, which explains the site limitations and offers an alternative retention volume. In such cases, the portion of 1 inch that cannot be retained must be provided with additional stormwater treatment so as to protect water quality. Any such treatment shall be designed, installed and maintained in accordance with the Stormwater Quality Manual.

For sites unable to comply with this section, the commissioner, at the commissioner's sole discretion, may require the submission of an individual permit in lieu of authorization under this general permit.

(3) Toxicity to Aquatic and Marine Life

The discharge shall not cause pollution due to acute or chronic toxicity to aquatic and marine life, impair the biological integrity of aquatic or marine ecosystems, or result in an unacceptable risk to human health.

(4) Water Quality Standards

The stormwater discharge shall not cause or contribute to an exceedance of the applicable Water Quality Standards in the receiving water.

(5) High Quality Waters

Any new or increased stormwater discharge to high quality waters shall be discharged in accordance with the Connecticut Anti-Degradation Implementation Policy in the Water Quality Standards.

(b) Stormwater Pollution Control Plan

All registrants shall develop and maintain on-site a Stormwater Pollution Control Plan (Plan) for the construction activity authorized by this general permit. Once the construction activity begins, the permittee shall perform all actions required by such Plan and shall maintain compliance with the Plan thereafter. The Plan shall be designed to minimize (as defined in Section 2): (1) pollution caused by soil erosion and sedimentation during and after construction; and (2) stormwater pollution caused by use of the site after construction is completed.

(1) Development and Contents of Plan

(A) The Plan shall consist of site plan drawings and a narrative. The Plan shall be prepared in accordance with sound engineering practices, and shall be consistent with the Guidelines and the 2004 Connecticut Stormwater Quality Manual (available at <http://www.ct.gov/deep/stormwater>). The Plan shall also be consistent with any remedial action plan, closure plan or other plan required by any other DEEP permit.

(B) The Plan shall include, at a minimum, the following items:

(i) Site Plan

Site drawings indicating drainage patterns and approximate slopes anticipated after major grading activities, areas of soil disturbance, the location of major structural and non-structural controls (as specified in subsection 5(b)(2), below), the location of areas where stabilization practices are expected to occur, areas which will be vegetated following construction, monitored outfalls, surface waters, impaired waters (identifying those with and without a TMDL), high quality waters, inland wetlands, tidal wetlands, fresh-tidal wetlands, and locations where stormwater will be discharged to a surface water (both during and post-construction);

(ii) Site Description

(a) A narrative description of the nature of the construction activity;

(b) An estimate of the total area of the site and the total area of the site that is expected to be disturbed by construction activities;

(c) An estimate of the average runoff coefficient of the site after construction activities are completed;

(d) The name of the immediate receiving water(s) and the ultimate receiving water(s) of the discharges authorized by this general permit; and

(e) Extent of wetland acreage on the site.

(iii) Construction Sequencing

The Plan shall clearly identify the expected sequence of major construction activities on the site and corresponding erosion and sediment controls and shall include an estimated timetable for all construction activities, which shall be revised as necessary to keep the Plan current. Wherever possible, the site shall be phased to avoid the disturbance of over five acres at one time (or a lesser area of disturbance as required in the “Impaired Waters” section (Section 5(b)(3)). The Plan shall clearly show the limits of disturbance for the entire construction activity and for each phase.

(iv) Control Measures

The Plan shall include a description, in narrative and on the site plan drawings, of appropriate control measures that will be performed at the site to minimize the discharge of pollutants to waters of the state. Control measures shall be implemented in accordance with Section 5(b)(2) below. In addition, the following information shall be provided:

- (a) Calculations supporting the design of sediment and floatables removal controls pursuant to Section 5(b)(2)(C)(ii)(b).
- (b) Calculations supporting the design of velocity dissipation controls pursuant to Section 5(b)(2)(C)(ii)(c).

(v) Runoff Reduction and Low Impact Development (LID) Information

Where runoff reduction practices and/or LID measures are utilized, the following information shall be included in the site plan and narrative:

- (a) The location of the site’s streams, floodplains, all wetlands, riparian buffers, slopes 3:1 and steeper, and vegetation identified for preservation and non-disturbance during construction such as forested areas, hay fields, and old fields;
- (b) Natural drainage patterns, swales, and other drainage ways, that are not streams, floodplains, or wetland areas;
- (c) The location of all areas with soils suitable for infiltration¹ and areas of the site best suited for infiltration for the siting of runoff reduction practices and LID design measures;
- (d) The location of all areas unsuitable or least suitable for infiltration for the siting of areas of development/building;
- (e) The location of all post-construction stormwater management measures, runoff reduction practices and LID design measures developed pursuant to subsection 5(b)(2)(C)(i) below;
- (f) Identification of areas inappropriate for the infiltration of stormwater runoff from land uses with a significant potential for groundwater pollution;

¹ Infiltration rates must be measured by a field permeability test. The measured field design infiltration rate is equal to one-half the field-measured infiltration rate.

- (g) A narrative describing the nature, purpose, implementation and long-term maintenance of the post-construction measures, runoff reduction practices and LID design measures;
- (h) Calculations, for measures developed pursuant to Section 5(b)(2)(C)(i), illustrating the retention of the water quality volume or half the water quality volume for the site, as applicable, including a discussion of the impact of any runoff reduction and/or LID practices on these calculations.
- (i) A narrative describing any site constraints that prevent retention of the appropriate volume specified in Section 5(b)(2)(C)(i) including: an explanation of the site limitations; a description of the runoff reduction practices implemented; an explanation of why the amount retained constitutes the maximum extent achievable; an alternative retention volume; and a description of the measures used to provide additional stormwater treatment for sediment, floatables and nutrients above the alternate volume up to the water quality volume.
- (j) Calculations showing the proposed effective impervious cover for the site and, where necessary or appropriate for measures developed for linear projects pursuant to Section 5(b)(2)(C)(i), each outfall drainage area.

(vi) Inspections

The Plan shall include a narrative of all inspection personnel conducting the routine inspections, their responsibilities and procedures pursuant to subsection 5(b)(4)(B) below. The Plan shall also include documentation of the qualifications of the inspector(s) and the findings, actions and results of all inspections conducted at the site.

(vii) Monitoring

The Plan shall provide a narrative of the stormwater monitoring procedures pursuant to Section 5(c). This narrative shall include documentation of the monitoring frequency, personnel conducting monitoring, identification of monitored outfalls, methodology for monitoring, provisions for monitoring a linear project (if applicable), the site's normal working hours, the method for measuring turbidity and a copy of all monitoring records.

(viii) Contractors

- (a) The Plan shall clearly identify each contractor and subcontractor that will perform construction activities on the site that have the potential to cause pollution of the waters of the State. The Plan shall include a copy of the certification statement in the "Contractor Certification Statement" section, below, signed by each such contractor and subcontractor.

(b) Contractor Certification Statement

The Plan shall include the following certification signed by each contractor and subcontractor identified in the Plan as described above:

"I certify under penalty of the law that I have read and understand the terms and conditions of the General Permit for the Discharge of Stormwater and Dewatering Wastewaters from Construction Activities. I understand that as a contractor or

subcontractor at the site, I am authorized by this general permit, and must comply with the terms and conditions of this general permit, including, but not limited to, the requirements of the Stormwater Pollution Control Plan prepared for the site.”

The certification shall include the name and title of the person providing the signature; the name, address and telephone number of the contracting firm; the address (or other identifying description) of the site; and the date the certification is made.

(c) Subdivisions

Where individual lots in a subdivision or other common plan of development are conveyed or otherwise the responsibility of another person or municipality, those individual lot contractors shall be required to comply with the provisions of this general permit and the Stormwater Pollution Control Plan, and shall sign the certification statement in the “Contractor Certification Statement” section, above, regardless of lot size or disturbed area. In such cases, the permittee shall provide a copy of the Plan to each individual lot contractor, obtain signed certifications from such contractors and retain all signed certifications in the Plan.

(ix) Impaired Waters

For construction activities that discharge to impaired waters, as specified in “New Discharges to Impaired Waters” (Section 3(b)(12)), the Plan shall include a description of the provisions for controlling the construction and post-construction stormwater discharges to these waters pursuant to subsection 5(b)(3) below.

(2) Stormwater Control Measures

Control Measures are required Best Management Practices (BMPs) that the permittee must implement to minimize the discharge of pollutants from the permitted activity. The term “minimize” means reduce and/or eliminate to the extent achievable using control measures that are technologically available and economically practicable and achievable in light of best industry practice.

Control Measures shall be designed in accordance with the Guidelines, the Stormwater Quality Manual or the DOT Qualified Products List (http://www.ct.gov/dot/lib/dot/documents/dresearch/conndot_qpl.pdf). Use of controls to comply with the “Erosion and Sediment Controls” section (subsection (A) below) of this general permit that are not included in those resources must be approved by the commissioner or the commissioner’s designated agent. The narrative and drawings of controls shall address the following minimum components:

(A) Erosion and Sediment Controls

(i) Soil Stabilization and Protection

The Plan shall include a narrative and drawings of interim and permanent soil stabilization practices for managing disturbed areas and soil stockpiles, including a schedule for implementing the practices. The Permittee shall ensure that existing vegetation is preserved to the maximum extent practicable and that disturbed portions of the site are minimized and stabilized.

Where construction activities have permanently ceased or when final grades are reached in any portion of the site, stabilization and protection practices as specified in Chapter 5 of the Guidelines or as approved by the commissioner or his/ her designated agent shall be implemented within seven days. Areas that will remain disturbed but inactive for at least thirty days shall receive temporary seeding or soil protection within seven days in accordance with the Guidelines.

Areas that will remain disturbed beyond the seeding season as identified in the Guidelines, shall receive long-term, non-vegetative stabilization and protection sufficient to protect the site through the winter. In all cases, stabilization and protection measures shall be implemented as soon as possible in accordance with the Guidelines or as approved by the commissioner or his/ her designated agent.

A reverse slope bench is required for any slope steeper than 3:1 (horizontal: vertical) that exceeds 15 feet vertically, except when engineered slope stabilization structures or measures are included or a detailed soil mechanics analysis has been conducted to verify stability. Engineered analyses and measures must be designed by a CT licensed Professional Engineer with experience in geotechnical engineering or soil mechanics.

(ii) Structural Measures

The Plan shall include a narrative and drawings of structural measures to divert flows away from exposed soils, store flows or otherwise limit runoff and minimize the discharge of pollutants from the site. Unless otherwise specifically approved in writing by the commissioner or his/ her designated agent, or if otherwise authorized by another state or federal permit, structural measures shall be installed on upland soils.

For points of discharge from disturbed sites with a total contributing drainage area of between two to five acres, a temporary sediment trap must be installed in accordance with the Guidelines. For points of discharge from disturbed sites with a total contributing drainage area greater than five acres, a temporary basin must be designed and installed in accordance with the Guidelines. Such trap(s) or basin(s) must be maintained until final stabilization of the contributing area as defined in "Notice of Termination" (Section 6(a)).

The requirement for sediment traps or basins shall not apply to flows from off-site areas and flows from the site that are either undisturbed or have undergone final stabilization where such flows are diverted around the temporary sediment trap or basin. Any exceptions must be approved in writing by the commissioner or his/ her designated agent.

(iii) Maintenance

The Plan shall include a narrative of the procedures to maintain in good and effective operating conditions all erosion and sediment control measures, including vegetation, and all other protective measures identified in the site plan. Maintenance of all erosion and sediment controls shall be performed in accordance with the Guidelines, or more frequently as necessary, to protect the waters of the state from pollution.

(B) Dewatering Wastewaters

Dewatering wastewaters shall be managed in accordance with the Guidelines. Dewatering wastewaters discharged to surface waters shall be discharged in a manner that minimizes the discoloration of the receiving waters. The Plan shall include a narrative and drawings of the

operational and structural measures that will be used to ensure that all dewatering wastewaters will not cause scouring or erosion or contain suspended solids in amounts that could reasonably be expected to cause pollution of surface waters of the State. Unless otherwise specifically approved in writing by the commissioner or his/ her designated agent, or if otherwise authorized by another state or federal permit, dewatering measures shall be installed on upland soils.

No discharge of dewatering wastewater(s) shall contain or cause a visible oil sheen, floating solids, or foaming in the receiving water.

(C) Post-Construction Stormwater Management

The Plan shall include a narrative and drawings of measures that will be installed during the construction process to minimize the discharge of pollutants in stormwater discharges that will occur after construction operations have been completed. Post-construction stormwater management measures shall be designed and implemented in accordance with the Stormwater Quality Manual, the DOT Qualified Products List or as approved by the commissioner or his/ her designated agent in writing. Unless otherwise specifically provided by the commissioner in writing, or authorized by another state or federal permit, structural measures shall be placed on upland soils. The Plan shall include provisions to address the long-term maintenance of any post-construction stormwater management measure installed.

(i) Post-Construction Performance Standards

The permittee shall utilize runoff reduction practices (as defined in Section 2) to meet runoff volume requirements based on the conditions below. For sites unable to comply with these conditions, the commissioner, at the commissioner's sole discretion, may require the submission of an individual permit in lieu of authorization under this general permit.

(a) Redevelopment

For sites that are currently developed with an effective impervious cover of forty percent or more and for which the permittee is proposing redevelopment, the permittee shall design the site in such a manner as to retain on-site half the water quality volume (as defined in Section 2) for the site and provide additional stormwater treatment without retention for discharges up to the full water quality volume for sediment, floatables and nutrients to the maximum extent achievable using control measures that are technologically available and economically practicable and achievable in light of best industry practice. In cases where the permittee is not able to retain half the water quality volume, the permittee shall design the redevelopment to retain runoff volume to the maximum extent achievable using control measures that are technologically available and economically practicable and achievable in light of best industry practice. In such cases, additional stormwater treatment up to the full water quality volume is still required. Any such treatment shall be designed, installed and maintained in accordance with the Stormwater Quality Manual. If retention of the half the water quality volume is not achieved, the permittee shall submit a report to the commissioner describing: the measures taken to maximize runoff reduction practices on the site; the reasons why those practices constitute the maximum extent achievable; the alternative retention volume; and a description of the measures used to provide additional stormwater treatment above the alternate volume up to the water quality volume. In the case of linear redevelopment projects (e.g. roadway reconstruction or widening) for the developed portion of

the right of way: (1) for projects that may be unable to comply with the full retention standard, the alternate retention and treatment provisions may also be applied as specified above, or (2) for projects that will not increase the effective impervious cover within a given watershed, the permittee shall implement the additional stormwater treatment measures referenced above, but will not be required to retain half of the water quality volume.

(b) Other Development

The following performance standard applies to all sites that are currently undeveloped or are currently developed with less than forty percent effective impervious cover. For these sites, the permittee shall design the site to retain the water quality volume for the site. If there are site constraints that would prevent retention of this volume on-site (e.g., brownfields, capped landfills, bedrock, elevated groundwater, etc.), documentation must be submitted, for the commissioner's review and written approval, which: explains the site limitations; provides a description of the runoff reduction practices implemented; provides an explanation of why this constitutes the maximum extent achievable; offers an alternative retention volume; and provides a description of the measures used to provide additional stormwater treatment for sediment, floatables and nutrients above the alternate volume up to the water quality volume. Any such treatment shall be designed, installed and maintained in accordance with the Stormwater Quality Manual. In the case of linear projects that do not involve impervious surfaces (e.g. electrical transmission rights-of-way or natural gas pipelines), retention of the water quality volume is not required as long as the post-development runoff characteristics do not differ significantly from pre-development conditions.

(ii) Post-Construction Control Measures

(a) Runoff Reduction and Low Impact Development ("LID") Practices

The site design shall incorporate runoff reduction practices, low impact development ("LID") practices or other measures to meet the performance standards in subsection (i) above, promote groundwater recharge and minimize post-construction impacts to water quality. Please refer to Appendix B for additional guidance information.

(b) Suspended Solids and Floatables Removal

The permittee shall install post-construction stormwater management measures designed to minimize the discharge of suspended solids and floatables (e.g. oil and grease, other floatable liquids, floatable solids, trash, etc.) from stormwater. A goal of 80 percent removal of the annual sediment load from the stormwater discharge shall be used in designing and installing stormwater management measures. The Plan shall provide calculations supporting the capability of such measures in achieving this goal and any third-party verification, as applicable, of the sediment removal efficiencies of such measures. This goal is not intended to limit local approval authorities from requiring a higher standard pursuant to local requirements.

(c) Velocity Dissipation

Velocity dissipation devices shall be placed at discharge locations and along the length of any outfall channel as necessary to provide a non-erosive velocity flow to the receiving watercourse so that the natural physical and biological characteristics and functions are maintained and protected.

(D) Other Controls

The following additional controls shall be implemented:

(i) Waste Disposal: Best management practices shall be implemented to minimize the discharge of litter, debris, building materials, hardened concrete waste, or similar materials to waters of the State. A narrative of these practices shall be provided in the Plan.

(ii) Washout Areas

Washout of applicators, containers, vehicles and equipment for concrete, paint and other materials shall be conducted in a designated washout area. There shall be no surface discharge of washout wastewaters from this area. Such washout shall be conducted: (1) outside of any buffers and at least 50 feet from any stream, wetland or other sensitive resource; or (2) in an entirely self-contained washout system. The permittee shall clearly flag off and designate areas to be used for washing and conduct such activities only in these areas. The permittee shall direct all washwater into a container or pit designed such that no overflows can occur during rainfall or after snowmelt.

In addition, dumping of liquid wastes in storm sewers is prohibited. The permittee shall remove and dispose of hardened concrete waste consistent with practices developed for the "Waste Disposal" section (subparagraph 5(b)(2)(D)(i), above). At least once per week, the permittee must inspect any containers or pits used for washout to ensure structural integrity, adequate holding capacity, and to check for leaks or overflows. If there are signs of leaks, holes or overflows in the containers or pits that could lead to a discharge, the permittee shall repair them prior to further use. For concrete washout areas, the permittee shall remove hardened concrete waste whenever the hardened concrete has accumulated to a height of ½ of the container or pit or as necessary to avoid overflows. A narrative of maintenance procedures and a record of maintenance and inspections shall be included in the Plan.

(iii) Off-site vehicle tracking of sediments and the generation of dust shall be minimized. Wet dust suppression shall be used, in accordance with section 22a-174-18(b) of the Connecticut General Statutes, for any construction activity that causes airborne particulates. The volume of water sprayed for controlling dust shall be minimized so as to prevent the runoff of water. No discharge of dust control water shall contain or cause a visible oil sheen, floating solids, visible discoloration, or foaming in the receiving stream.

(iv) All post-construction stormwater structures shall be cleaned of construction sediment and any remaining silt fence shall be removed upon stabilization of the site.

(v) All chemical and petroleum product containers stored on the site (excluding those contained within vehicles and equipment) shall be provided with impermeable containment which will hold at least 110% of the volume of the largest container, or

10% of the total volume of all containers in the area, whichever is larger, without overflow from the containment area. All chemicals and their containers shall be stored under a roofed area except for those chemicals stored in containers of 100 gallon capacity or more, in which case a roof is not required. Double-walled tanks satisfy this requirement.

(3) Additional Control Measures for Impaired Waters

For construction activities that discharge directly to impaired waters, as specified in “New Discharges to Impaired Waters” (Section 3(b)(12)), the Plan shall include the following provisions:

- (A) In lieu of the provisions of “Construction Sequencing” (Section 5(b)(1)(B)(iii)), no more than 3 acres may be disturbed at any one time. For those areas for which construction activity will be temporarily suspended for a period of greater than 14 days, temporary stabilization measures shall be implemented within 3 days of such suspension of activity. For all areas, permanent stabilization shall be implemented within 30 days of disturbance; *or*
- (B) The Plan shall document that measures are in place to ensure that there will be no discharge to the impaired water from rain events up to a 2-year, 24-hour rain event while construction activity is occurring; *or*
- (C) For discharges to impaired waters with an established TMDL:
 - (i) the Plan shall document that there is sufficient remaining Waste Load Allocation (WLA) in the TMDL to allow the discharge, *and*
 - (ii) measures shall be implemented to ensure the WLA will not be exceeded, *and*
 - (iii) stormwater discharges shall be monitored, if applicable, for any indicator pollutant identified in the TMDL for every rain event that produces a discharge to ensure compliance with the WLA. Such monitoring shall be in addition to the requirements specified in Section 5(c), *or*
 - (iv) the specific requirements for stormwater discharges specified in the TMDL are met.

Construction activities discharging to impaired waters that do not comply with this subsection are not authorized by this general permit.

(4) Inspections

All construction activities submitting a registration for this general permit shall be inspected initially for Plan implementation and then weekly for routine inspections.

(A) Plan Implementation Inspections

Within the first 30 days following commencement of the construction activity on the site, the permittee shall contact: (1) the appropriate District; or (2) a qualified soil erosion and sediment control professional or a qualified professional engineer to inspect the site. The site shall be inspected at least once and no more than three times during the first 90 days to confirm compliance with the general permit and proper initial implementation of all controls measures designated in the Plan for the site for the initial phase of construction. For sites not inspected by District personnel, the following conditions shall apply:

- (i) for projects disturbing more than one acre and less than fifteen (15) acres, the inspector shall be someone who:
 - (a) is not an employee, as defined by the Internal Revenue Service in the Internal Revenue Code of 1986, of the registrant, and
 - (b) has no ownership interest of any kind in the project for which the registration is being submitted.
- (ii) for projects disturbing fifteen (15) acres or more, the inspector shall be someone who:
 - (a) is not an employee, as defined by the Internal Revenue Service in the Internal Revenue Code of 1986, of the registrant, and
 - (b) has not engaged in any activities associated with the preparation, planning, designing or engineering of such plan for soil erosion and sediment control or plan for engineered stormwater management systems on behalf of such registrant, and
 - (c) is not under the same employ as any person who engaged in any activities associated with the preparation, planning, designing or engineering of such plans and specifications for soil erosion and sediment control or plans and specifications for engineered stormwater management systems on behalf of such registrant, and
 - (d) has no ownership interest of any kind in the project for which the registration is being submitted.

The permittee may use, if they wish, the same person(s) that provided the Plan Review Certification pursuant to Section 5(b)(11).

(B) Routine Inspections

The permittee shall routinely inspect the site for compliance with the general permit and the Plan for the site until a Notice of Termination has been submitted. Inspection procedures for these routine inspections shall be addressed and implemented in the following manner:

- (i) The permittee shall maintain a rain gauge on-site to document rainfall amounts. At least once a week and within 24 hours of the end of a storm that generates a discharge, a qualified inspector (provided by the permittee), as defined in the “Definitions” section (Section 2) of this general permit, shall inspect, at a minimum, the following: disturbed areas of the construction activity that have not been finally stabilized; all erosion and sedimentation control measures; all structural control measures; soil stockpile areas; washout areas and locations where vehicles enter or exit the site. These areas shall be inspected for evidence of, or the potential for, pollutants entering the drainage system and impacts to the receiving waters. Locations where vehicles enter or exit the site shall also be inspected for evidence of off-site sediment tracking. For storms that end on a weekend, holiday or other time after which normal working hours will not commence within 24 hours, an inspection is required within 24 hours only for storms that equal or exceed 0.5 inches. For storms of less than 0.5 inches, an inspection shall occur immediately upon the start of the subsequent normal working hours. Where sites have been temporarily or finally stabilized, such inspection shall be conducted at least once every month for three months.
- (ii) The qualified inspector(s) shall evaluate the effectiveness of erosion and sediment controls, structural controls, stabilization practices, and any other controls implemented

to prevent pollution and determine if it is necessary to install, maintain, or repair such controls and/or practices to improve the quality of stormwater discharge(s).

- (iii) A report shall be prepared and retained as part of the Plan. This report shall summarize: the scope of the inspection; name(s) and qualifications of personnel making the inspection; the date(s) of the inspection; weather conditions including precipitation information; major observations relating to erosion and sediment controls and the implementation of the Plan; a description of the stormwater discharge(s) from the site; and any water quality monitoring performed during the inspection. The report shall be signed by the permittee or his/her authorized representative in accordance with the "Certification of Documents" section (subsection 5(i)) of this general permit.

The report shall include a statement that, in the judgment of the qualified inspector(s) conducting the site inspection, the site is either in compliance or out of compliance with the terms and conditions of the Plan and permit. If the site inspection indicates that the site is out of compliance, the inspection report shall include a summary of the remedial actions required to bring the site back into compliance. Non-engineered corrective actions (as identified in the Guidelines) shall be implemented on site within 24 hours and incorporated into a revised Plan within three (3) calendar days of the date of inspection unless another schedule is specified in the Guidelines. Engineered corrective actions (as identified in the Guidelines) shall be implemented on site within seven (7) days and incorporated into a revised Plan within ten (10) days of the date of inspection, unless another schedule is specified in the Guidelines or is approved by the commissioner. During the period in which any corrective actions are being developed and have not yet been fully implemented, interim measures shall be implemented to minimize the potential for the discharge of pollutants from the site.

- (iv) Inspectors from the DEEP and the appropriate District may inspect the site for compliance with this general permit at any time construction activities are ongoing and upon completion of construction activities to verify the final stabilization of the site and/or the installation of post-construction stormwater management measures pursuant to Section 6(a).
- (v) Additional inspections, reports and documentation may also be required to comply with the "Monitoring Requirements" section (Section 5(c)).

(5) Keeping Plans Current

The Permittee is responsible for keeping their Plan in compliance with this general permit at all times. This may involve any or all of the following:

- (A) The permittee shall amend the Plan if the actions required by the Plan fail to prevent pollution or fail to otherwise comply with any other provision of this general permit. The Plan shall also be amended whenever there is a change in contractors or subcontractors at the site, or a change in design, construction, operation, or maintenance at the site which has the potential for the discharge of pollutants to the waters of the state and which has not otherwise been addressed in the Plan.
- (B) The commissioner may notify the permittee at any time that the Plan and/or the site do not meet one or more of the minimum requirements of this general permit. Within 7 days of such notice, or such other time as the commissioner may allow, the permittee shall make the required changes to the Plan and perform all actions required by such revised Plan. Within 15 days of such notice, or such other time as the commissioner may allow, the permittee shall submit to the commissioner a written certification that the requested changes have been

made and implemented and such other information as the commissioner requires, in accordance with the „Duty to Provide Information” and “Certification of Documents” sections (subsections 5(h) and 5(i)) of this general permit.

- (C) For any stormwater discharges authorized under any previous version of this general permit, the existing Plan shall be updated by February 1, 2014, as applicable, in accordance with the “Development and Contents of the Plan” (subsection 5(b)(1)), “Stormwater Control Measures” (subsection 5(b)(2)), “Routine Inspections” (subsection 5(b)(4)(B)), and “Monitoring” (subsection 5(c)) sections of this general permit, except for the post-construction measures in subsection 5(b)(2)(C)(i)(a) & (b) and 5(b)(2)(C)(ii)(a). The permittee shall maintain compliance with such Plan thereafter. For previously authorized sites discharging to impaired waters or other sensitive areas, the commissioner may require additional control measures or provide authorization under an individual permit pursuant to Sections 4(h) and 3(i).

(6) Failure to Prepare, Maintain or Amend Plan

In no event shall failure to complete, maintain or update a Plan, in accordance with the “Development of Contents of the Plan” and “Keeping Plans Current” sections (subsections 5(b)(1) and 5(b)(5)) of this general permit, relieve a permittee of responsibility to implement any actions required to protect the waters of the state and to comply with all conditions of the permit.

(7) Plan Signature

The Plan shall be signed and certified as follows:

- (A) The Plan shall be signed by the permittee in accordance with the “Certification of Documents” section (subsection 5(i)) of this general permit.
- (B) The Plan shall include certification by all contractors and subcontractors in accordance with the “Contractors” section (subsection 5(b)(1)(B)(viii)) of this general permit.
- (C) The Plan shall include a copy of the certification by a professional engineer or landscape architect made in accordance with Section 3(b)(9) of this general permit.

(8) Plan Review Certification

For a locally approvable project pursuant to Section 3(c) of this general permit, a copy of the Plan review certification made in accordance with either Section 3(b)(10) or (11) shall be maintained with the Plan. Note that construction activities reviewed and certified pursuant to those sections are still subject to the local erosion and sediment control and stormwater management regulations of the municipality in which the activity is conducted.

(9) Plan Submittal

The Plan shall be submitted to the commissioner and other certain parties under the following conditions:

- (A) All Locally Exempt Projects with greater than one acre of soil disturbance shall submit an electronic copy of the Plan and a completed Registration Form to the commissioner.
- (B) For all other projects, the permittee shall provide a copy of the Plan, and a completed Registration Form for this general permit to the following persons immediately upon request:

- (i) The commissioner at his or her request or at the request of a member of the public during the registration and Plan availability period pursuant to Section 4(e);
- (ii) The municipal planning commission, zoning commission and/or inland wetlands agency, or its respective enforcement officer or designated agent;
- (iii) In the case of a stormwater discharge through a municipal separate storm sewer system, the municipal operator of the system;
- (iv) In the case of a stormwater discharge located within a public drinking water supply watershed or aquifer area, the water company responsible for that water supply.

DO NOT SUBMIT any pages or other material that do not pertain to stormwater management or erosion and sedimentation control (such as electrical and lighting plans, boundary or lot surveys, building plans, non-stormwater related detail sheets, etc.).

(c) Monitoring Requirements

The primary requirements for monitoring turbidity are summarized in the table below:

Table 1

<i>Area of Soil Disturbance</i>	<i>Monitoring Required?</i>	<i>Monitoring Frequency</i>	<i>Sample Method</i>
Sites which disturb 1 acre or more, but less than 5 acres	Only IF a Registration is required	Monthly IF a Registration is required	Procedure consistent with 40 CFR Part 136
Sites which disturb 5 acres or more	Yes	Monthly	Procedure consistent with 40 CFR Part 136

(1) Turbidity Monitoring Requirements

(A) Monitoring Frequency

- (i) Sampling shall be conducted in accordance with Table 1, above, at least once every month, when there is a discharge of stormwater from the site while construction activity is ongoing, until final stabilization of the drainage area associated with each outfall is achieved.
- (ii) The permittee is only required to take samples during normal working hours as defined in Section 2. The site’s normal working hours must be identified in the Plan pursuant to Section 5(b)(1)(B)(vii). If sampling is discontinued due to the end of normal working hours, the permittee shall resume sampling the following morning or the morning of the next working day following a weekend or holiday, as long as the discharge continues.
- (iii) Sampling may be temporarily suspended any time conditions exist that may reasonably pose a threat to the safety of the person taking the sample. Such conditions may include high winds, lightning, impinging wave or tidal activity, intense rainfall or other

hazardous condition. Once the unsafe condition is no longer present, sampling shall resume.

(iv) If there is no stormwater discharge during a month, sampling is not required.

(B) Sample Collection

- (i) All samples shall be collected from discharges resulting from a storm event that occurs at least 24 hours after any previous storm event generating a stormwater discharge. Any sample containing snow or ice melt must be identified on the Stormwater Monitoring Report form. Sampling of snow or ice melt in the absence of a storm event is not a valid sample.
- (ii) Samples shall be grab samples taken *at least* three separate times during a storm event and shall be *representative* of the flow and characteristics of the discharge(s). Samples may be taken manually or by an in-situ turbidity probe or other automatic sampling device equipped to take individual turbidity readings (i.e. not composite). The first sample shall be taken within the first hour of stormwater discharge from the site. In cases where samples are collected manually and the discharge begins outside of normal working hours, the first sample shall be taken at the start of normal working hours.

(C) Sampling Locations

(i) Sampling is required of all point source discharges of stormwater from disturbed areas except as may be modified for linear projects under subparagraph (ii) below. Where there are two or more discharge points that discharge substantially identical runoff, based on similarities of the exposed soils, slope, and type of stormwater controls used, a sample may be taken from just one of the discharge points. In such case, the permittee shall report that the results also apply to the substantially identical discharge point(s). No more than 5 substantially identical outfalls may be identified for one representative discharge. If such project is planned to continue for more than one year, the permittee shall rotate twice per year the location where samples are taken so that a different discharge point is sampled every six months. The Plan must identify each outfall authorized by this permit and describe the rationale for any substantially identical outfall determinations.

(ii) Linear Projects

For a linear project, as defined in Section 2, the protocols of subparagraph (i), above, shall apply except that up to 10 substantially identical outfalls may be identified for one representative discharge.

(iii) All sampling point(s) shall be identified in the Plan and be clearly marked in the field with a flag, stake, or other visible marker.

(D) Sampling and analysis shall be prescribed by 40 CFR Part 136.

(E) Turbidity Values

The stormwater discharge turbidity value for each sampling point shall be determined by taking the average of the turbidity values of all samples taken at that sampling point during a given storm.

(2) Stormwater Monitoring Reports

- (A) Within thirty (30) days following the end of each month, permittees shall enter the stormwater sampling result(s) on the Stormwater Monitoring Report (SMR) form (available at www.ct.gov/deep/stormwater) and submit it in accordance with the NetDMR provisions in subsection F, below, or, if the permittee has opted out of NetDMR, to the following address:

Bureau of Materials Management and Compliance Assurance
Water Permitting and Enforcement Division (Attn: DMR Processing)
Connecticut Department of Energy and Environmental Protection
79 Elm Street
Hartford, CT 06106-5127

- (B) If there was no discharge during any given monitoring period, the permittee shall submit the form as required with the words “no discharge” entered in place of the monitoring results.
- (C) If the permittee monitors any discharge more frequently than required by this general permit, the results of this monitoring shall be included in additional SMRs for the month in which the samples were collected.
- (D) If sampling protocols are modified due to the limitations of normal working hours or unsafe conditions in accordance with Section 5(c)(1)(A)(ii) or (iii) above, a description of and reason for the modifications shall be included with the SMR.
- (E) If the permittee samples a discharge that is representative of two or more substantially identical discharge points, the permittee shall include the names or locations of the other discharge points.
- (F) NetDMR Reporting Requirements
- (i) Prior to one-hundred and eighty (180) days after the issuance of this permit, the Permittee may either submit monitoring data and other reports to the Department in hard copy form or electronically using NetDMR, a web-based tool that allows Permittees to electronically submit stormwater monitoring reports through a secure internet connection. Unless otherwise approved in writing by the commissioner, no later than one-hundred and eighty (180) days after the issuance of this permit the Permittee shall begin reporting electronically using NetDMR. Specific requirements regarding subscription to NetDMR and submittal of data and reports in hard copy form and for submittal using NetDMR are described below:

(a) Submittal of NetDMR Subscriber Agreement

On or before fifteen (15) days after the issuance of this permit, the Permittee and/or the person authorized to sign the Permittee’s discharge monitoring reports (“Signatory Authority”) as described in RCSA Section 22a-430-3(b)(2) shall contact the Department at deep.netdmr@ct.gov and initiate the NetDMR subscription process for electronic submission of Stormwater Monitoring Report information. Information on NetDMR is available on the Department’s website at www.ct.gov/deep/netdmr. On or before ninety (90) days after issuance of this permit the Permittee shall submit a signed and notarized copy of the *Connecticut DEEP NetDMR Subscriber Agreement* to the Department.

(b) Submittal of Reports Using NetDMR

Unless otherwise approved by the commissioner, on or before one-hundred and eighty (180) days after issuance of this permit, the Permittee and/or the Signatory Authority shall electronically submit SMRs required under this permit to the Department using NetDMR in satisfaction of the SMR submission requirements of Sections 5(c)(2)(A) of this permit.

SMRs shall be submitted electronically to the Department no later than the 30th day of the month following the completed reporting period. Any additional monitoring conducted in accordance with 40 CFR 136 shall be submitted to the Department as an electronic attachment to the SMR in NetDMR. Once a Permittee begins submitting reports using NetDMR, it will no longer be required to submit hard copies of SMRs to the Department. NetDMR is accessed from: <http://www.epa.gov/netdmr>.

(c) Submittal of NetDMR Opt-Out Requests

If the Permittee is able to demonstrate a reasonable basis, such as technical or administrative infeasibility, that precludes the use of NetDMR for electronically submitting SMRs, the commissioner may approve the submission of SMRs in hard copy form (“opt-out request”). Opt-out requests must be submitted in writing to the Department for written approval on or before fifteen (15) days prior to the date a Permittee would be required under this permit to begin filing SMRs using NetDMR. This demonstration shall be valid for twelve (12) months from the date of the Department’s approval and shall thereupon expire. At such time, SMRs shall be submitted electronically to the Department using NetDMR unless the Permittee submits a renewed opt-out request and such request is approved by the Department.

All opt-out requests and requests for the NetDMR subscriber form should be sent to the following address or by email at deep.netdmr@ct.gov:

Attn: NetDMR Coordinator
Connecticut Department of Energy and Environmental Protection
79 Elm Street
Hartford, CT 06106-5127

(d) *Reporting and Record Keeping Requirements*

- (1) For a period of at least five years from the date that construction is complete, the permittee shall retain copies of the Plan and all reports required by this general permit, and records of all data used to complete the registration for this general permit, unless the commissioner specifies another time period in writing. Inspection records must be retained as part of the Plan for a period of five (5) years after the date of inspection.
- (2) The permittee shall retain an updated copy of the Plan required by this general permit at the construction site from the date construction is initiated at the site until the date construction at the site is completed.

(e) *Regulations of Connecticut State Agencies Incorporated into this General Permit*

The permittee shall comply with sections 22a-430-3 and 22a-430-4 of the Regulations of Connecticut State Agencies which are hereby incorporated into this general permit, as if fully set forth herein.

(f) *Reliance on Registration*

In evaluating the registrant's registration, the commissioner has relied on information provided by the registrant. If such information proves to be false or incomplete, any authorization reliant on such information may be suspended or revoked in accordance with law, and the commissioner may take any other legal action provided by law.

(g) *Duty to Correct and Report Violations*

Upon learning of a violation of a condition of this general permit, unless otherwise specified in this general permit, a permittee shall immediately take all reasonable action to determine the cause of such violation, correct and mitigate the results of such violation, prevent further such violation, and report in writing such violation and such corrective action to the commissioner within five (5) days of the permittee's learning of such violation. Such information shall be filed in accordance with the "Certification of Documents" section (Section 5(i)) of this general permit.

(h) *Duty to Provide Information*

If the commissioner requests any information pertinent to the construction activity or to compliance with this general permit or with the permittee's authorization under this general permit, the permittee shall provide such information within fifteen (15) days of such request or other time period as may be specified in writing by the commissioner. Such information shall be filed in accordance with the "Certification of Documents" section (Section 5(i)) of this general permit.

(i) *Certification of Documents*

Unless otherwise specified in this general permit, any document, including but not limited to any notice, information or report, which is submitted to the commissioner under this general permit shall be signed by the permittee, or a duly authorized representative of the permittee, and by the individual or individuals responsible for actually preparing such document, each of whom shall certify in writing as follows:

"I have personally examined and am familiar with the information submitted in this document and all attachments thereto, and I certify that, based on reasonable investigation, including my inquiry of those individuals responsible for obtaining the information, the submitted information is true, accurate and complete to the best of my knowledge and belief. I understand that a false statement made in this document or its attachments may be punishable as a criminal offense, in accordance with section 22a-6 of the Connecticut General Statutes, pursuant to section 53a-157b of the Connecticut General Statutes, and in accordance with any other applicable statute."

(j) *Date of Filing*

For purposes of this general permit, the date of filing with the commissioner of any document is the date such document is received by the commissioner. The word "day" as used in this general permit means the calendar day; if any date specified in the general permit falls on a Saturday, Sunday, or legal holiday, such deadline shall be the next business day thereafter.

(k) *False Statements*

Any false statement in any information submitted pursuant to this general permit may be punishable as a criminal offense, in accordance with section 22a-6 of the Connecticut General Statutes, pursuant to section 53a-157b of the Connecticut General Statutes.

(l) *Correction of Inaccuracies*

Within fifteen (15) days after the date a permittee becomes aware of a change in any information in any material submitted pursuant to this general permit, or becomes aware that any such information is inaccurate or misleading or that any relevant information has been omitted, such permittee shall correct the inaccurate or misleading information or supply the omitted information in writing to the commissioner. Such information shall be filed in accordance with the certification requirements prescribed in Section 5(i) of this general permit.

(m) *Transfer of Authorization*

Any authorization issued by the commissioner under this general permit is transferable only in accordance with the provisions of section 22a-6o of the General Statutes. Any person or municipality proposing to transfer any such authorization shall submit a license transfer form to the commissioner. The transferee is not authorized to conduct any activities under this general permit until the transfer is approved by the commissioner (typically 30 days). The transferee may adopt by reference the Plan developed by the transferor. The transferee shall amend the Plan as required by the “Keeping Plans Current” Section 5(b)(5) of this general permit).

(n) *Reopener*

At such time as the USEPA may institute a new rule for post-construction stormwater management or modify the requirements for their National Pollutant Discharge Elimination System (NPDES) General Permit for Discharges from Construction Activities (CGP) to institute a numeric Effluent Limitation Guideline (ELG) for turbidity in stormwater discharges from construction activities, the commissioner may reopen this general permit pursuant to the Section 40 Part 122.62(a) of the Code of Federal Regulations for implementation of these elements.

(o) *Other Applicable Law*

Nothing in this general permit shall relieve the permittee of the obligation to comply with any other applicable federal, state and local law, including but not limited to the obligation to obtain any other authorizations required by such law.

(p) *Other Rights*

This general permit is subject to and does not derogate any present or future rights or powers of the State of Connecticut and conveys no rights in real or personal property nor any exclusive privileges, and is subject to all public and private rights and to any federal, state, and local laws pertinent to the property or construction activity affected by such general permit. In conducting any construction activity authorized hereunder, the permittee may not cause pollution, impairment, or destruction of the air, water, or other natural resources of this state. The issuance of this general permit shall not create any presumption that this general permit should or will be renewed.

Section 6. Termination Requirements

(a) *Notice of Termination*

At the completion of a construction project registered pursuant to the “Registration Requirements” section (Section 4) of this general permit, a Notice of Termination must be filed with the commissioner. A project shall be considered complete after all post-construction measures are installed, cleaned and functioning and the site has been stabilized for at least three months following the cessation of construction activities. A site is considered stabilized when there is no active erosion or sedimentation present and no disturbed areas remain exposed **for all phases**.

(1) Post-Construction Inspection

For locally approvable projects, once all post-construction stormwater measures have been installed in accordance with the Post-Construction Stormwater Management section (subsection 5(b)(2)(C)) and cleaned of any construction sediment or debris, the registrant shall contact the appropriate Conservation District or a qualified soil erosion and sediment control professional and/or a qualified professional engineer, as appropriate, who will inspect the site to confirm compliance with these post-construction stormwater measures. This person(s) shall not be an employee, as defined by the Internal Revenue Service in the Internal Revenue Code of 1986, of the permittee and shall have no ownership interest of any kind in the project for which the site’s registration was submitted.

(2) Final Stabilization Inspection

For all projects, once the site has been stabilized for at least three months, the registrant shall have the site inspected by a qualified inspector to confirm final stabilization. The registrant shall indicate compliance with this requirement on the Notice of Termination form.

(b) *Termination Form*

A termination notice shall be filed on forms prescribed and provided by the commissioner and shall include the following:

- (1) The permit number as provided to the permittee on the permit certificate.
- (2) The name of the registrant as reported on the general permit registration form (DEEP-PED-REG-015).
- (3) The address of the completed construction site.
- (4) The dates when:
 - (A) All storm drainage structures were cleaned of construction debris pursuant to the “Other Controls” section (subsection 5(b)(2)(D)) of this general permit; and
 - (B) The post-construction inspection was conducted pursuant to subsection 6(a)(1), above; and
 - (C) The date of completion of construction; and
 - (D) The date of the final stabilization inspection pursuant to subsection 6(a)(2), above.
- (5) A description of the post-construction activities at the site.

(6) Signatures of:

(A) The permittee; and

(B) The person certifying the post-construction inspection pursuant to subsection 6(a)(1), above.

(c) *Where to File a Termination Form*

A termination form shall be filed with the commissioner at the following address:

CENTRAL PERMITS PROCESSING UNIT
BUREAU OF MATERIALS MANAGEMENT & COMPLIANCE ASSURANCE
DEPARTMENT OF ENERGY & ENVIRONMENTAL PROTECTION
79 ELM STREET
HARTFORD, CT 06106-5127

Section 7. Commissioner's Powers

(a) *Abatement of Violations*

The commissioner may take any action provided by law to abate a violation of this general permit, including but not limited to penalties of up to \$25,000 per violation per day under Chapter 446k of the Connecticut General Statutes, for such violation. The commissioner may, by summary proceedings or otherwise and for any reason provided by law, including violation of this general permit, revoke a permittee's authorization hereunder in accordance with sections 22a-3a-2 through 22a-3a-6, inclusive, of the Regulations of Connecticut State Agencies. Nothing herein shall be construed to affect any remedy available to the commissioner by law.

(b) *General Permit Revocation, Suspension, or Modification*

The commissioner may, for any reason provided by law, by summary proceedings or otherwise, revoke or suspend this general permit or modify to establish any appropriate conditions, schedules of compliance, or other provisions which may be necessary to protect human health or the environment.

(c) *Filing of an Individual Permit Application*

If the commissioner notifies a permittee in writing that such permittee must obtain an individual permit if he wishes to continue lawfully conducting the construction activity, the permittee shall file an application for an individual permit within thirty (30) days of receiving the commissioner's notice. While such application is pending before the commissioner, the permittee shall continue to comply with the terms and conditions of this general permit. Nothing herein shall affect the commissioner's power to revoke a permittee's authorization under this general permit at any time.

Issued:

August 21, 2013

Daniel C. Esty
Commissioner

General Permit for the Discharge of Stormwater and Dewatering Wastewaters from Construction Activities

APPENDIX A

Endangered and Threatened Species

In order to be eligible for coverage under the General Permit for the Discharge of Stormwater and Dewatering Wastewaters from Construction Activities (“GP” or “the GP”), under section 3(b)(2) of the GP, a registrant must ensure that the construction activity, which includes, but is not limited to, excavation, site development or other ground disturbance activities, and stormwater flow, discharges and control measures (“construction activity”), does not threaten the continued existence of any state or federal species listed as endangered or threatened (“listed species”) or result in the destruction or adverse modification of any habitat associated with such species.

In order to prevent significant, unforeseen delays in the processing of a registration under the GP, registrants should assess compliance with section 3(b)(2) early in the planning stages of a project. The Department of Energy and Environmental Protection (“the Department”) strongly recommends that this assessment *be initiated up to one year, or more*, prior to the projected construction initiation date, and even before the purchase of the site of the construction activity. At a minimum, registrants must assess compliance with section 3(b)(2) prior to submission of the Registration Form for the GP.

This Appendix describes the ways that a registrant can comply with section 3(b)(2) of the GP. In connection with the filing of a registration a registrant can perform a self-assessment described in Section 1, seek a limited one-year determination or a safe harbor determination from the Department’s Wildlife Division under Sections 2 or 3, respectively, or stipulate in writing to the presence of listed species or any habitat associated with such species and develop a mitigation plan pursuant to Section 5 of this Appendix. While some means of compliance are more limited than others, the options set out in this Appendix are not mutually exclusive and all options remain available to a registrant. For example, a registrant may perform a self-assessment under Section 1 and seek a safe harbor determination under Section 3 of this Appendix. Provided the requirements of this Appendix are met, the choice of how to proceed is the registrant’s.

Section 1. Self Assessment through Natural Diversity Database Map Review and Screening

Before submission of a registration for coverage under this GP, a registrant must review the current versions of the Department’s Natural Diversity Data Base (“NDDB”) maps. Except as provided for in Sections 2, 3 or 5 of this Appendix, such review must occur no more than six months before such submission. Such review provides a method for screening whether the Department is already aware of listed species that may be present on the site of the construction activity. These maps can be viewed at the following locations:

1. Online at the following links:

[CT DEEP Natural Diversity Data Base Maps](#)
[CTECO Webpage](#) (in the interactive Simple Map Viewer)

2. At the DEEP Public File Room at 79 Elm Street in Hartford.

Screening

The site of the construction activity must be compared to the shaded areas depicted on the NDDDB map to determine if the site is entirely, partially, or within ¼ mile of a shaded area. If the site is entirely, partially or within a ¼ mile of a shaded area for a listed species a registrant can only achieve compliance with section 3(b)(2) of the GP by obtaining a limited one-year determination under Section 2, a safe harbor determination under Section 3, or an approved mitigation plan under Section 5 of this Appendix from the Department's Wildlife Division.

If the site of the construction activity is not entirely, partially or within ¼ mile of a shaded area, then the Department is not aware of any listed species at the site of the construction activity. Based upon this screening, and provided the registrant has no reasonably available verifiable, scientific or other credible information that the construction activity could reasonably be expected to violate section 3(b)(2) of the GP, when completing the Registration Form for this GP a registrant may check the box that indicates that the construction activity will not impact federal or state listed species.

A registrant using only self-assessment under this section may utilize the results of any such self assessment for up to, but no more than, six months from the date of such assessment. Note, however, that the NDDDB maps are not the result of comprehensive state-wide field investigations, but rather serve as a screening tool. Using such maps as a screening tool does not provide a registrant with an assurance that listed species or their associated habitat may not be encountered at the site of the construction activity. Notwithstanding the NDDDB screening results, if a listed species is encountered at the site of the construction activity, the registrant shall promptly contact the Department and may need to take additional action to ensure that the registrant does not violate section 3(b)(2) of the GP.

Section 2. Obtaining a Limited One-Year Determination

A registrant may seek a written determination from the Department's Wildlife Division, good for one-year, that the proposed construction activity complies with section 3(b)(2) of the GP. To obtain this limited one-year determination, a registrant must, in addition to conducting the NDDDB map review in Section 1 of this Appendix, provide the Department's Wildlife Division with (1) any reasonably available verifiable, scientific or other credible information about whether the construction activity could reasonably be expected to result in a violation of section 3(b)(2) of the GP, and (2) limited information about the site of the proposed construction activity, but less information than would be necessary for a safe harbor determination under Section 3 of this Appendix. The limited information necessary for a one-year determination is on the current "Request for Natural Diversity Database (NDDDB) State Listed Species Review" form on the Department's website. The form and instructions for seeking such a limited one-year determination are available at www.ct.gov/DEEP/nddbrequest.

Provided the registrant's information is accurate and the Department's Wildlife Division determines that the construction activity will not violate section 3(b)(2) of the GP, the registrant shall receive a limited one-year determination from the Department. Any such determination may indicate that the construction activity will not impact listed species or their associated habitat, or it may include specific conditions to be implemented to avoid or significantly minimize any impacts that may be encountered at the site of the construction activity. For purposes of submitting a registration for the GP, any such limited one-year determination can be relied upon by the person receiving such determination for one-year from the date of such determination. Like, however, the NDDDB screening procedure in Section 1 of this Appendix, a limited one-year determination does not provide a registrant with an assurance that listed species or their associated habitat may not be encountered at the site of the construction activity. If a listed species is encountered, the registrant shall promptly contact the Department

and may need to take additional action to ensure that the construction activity does not violate section 3(b)(2) of the GP.

If a registrant receives a limited one-year determination from the Department, the registrant should check the limited one-year determination box on the GP registration form and include the Department's one-year limited determination letter if requested on the GP Registration form. Checking the limited one-year determination box on the registration form and failing to provide the determination letter from the Department's Wildlife Division, if requested on the GP Registration form, will delay and may prevent processing of a registration.

If based upon the information provided by a registrant seeking a limited one-year determination the Department's Wildlife Division determines that the construction activity could impact listed species or their associated habitat, or that the Department needs additional information to make a limited one-year determination, the registrant may still achieve compliance with section 3(b)(2) of the GP through providing additional information pursuant to Section 4 or developing a mitigation plan pursuant to Section 5 of this Appendix.

A registrant may request one or more one-year extensions to a limited one-year determination under this section. If the Department's Wildlife Division has prescribed a form for requesting an extension, any such request shall be made using the prescribed form. There is a presumption that requests for a one-year extension of a limited one-year determination shall be granted. However, this presumption can be rebutted if the Department determines that a change in any of the following has occurred since an initial limited one-year determination or any extension was granted: the construction activity affecting or potentially affecting listed species or their associated habitat; the NDDB maps for the site of the construction activity; the limited information upon which a limited one-year determination or any extension was granted; or other information indicative of a change in circumstance affecting listed species or their associated habitat. Any one-year extension granted under this paragraph shall run from the date the Department's Wildlife Division issues its determination to grant an extension and shall be treated as a limited one-year determination as provided for in this section. Any letter granting a one-year extension shall be included with a registration along with the original limited one-year determination as provided for in this section.

Section 3. Obtaining a Safe Harbor Determination

A registrant may seek a written determination from the Department's Wildlife Division, good for three years, with the potential to be extended for an additional year, that proposed construction activity complies with section 3(b)(2) of the GP. Any such determination shall constitute a "safe harbor" for purposes of section 3(b)(2) of the GP.

To obtain a safe harbor determination, a registrant must, in addition to conducting the NDDB review in section 1 of this Appendix, provide the Department's Wildlife Division with any reasonably available verifiable, scientific or other credible information about whether the construction activity could reasonably be expected to result in a violation of section 3(b)(2) of the GP and specific information about the site of the construction activity. The specific information necessary for a safe harbor determination is listed in Attachment A to this Appendix. This information must be sufficient to allow the Wildlife Division to adequately assess the site for potential risks to listed species and their associated habitat. While the Department recognizes certain information is necessary to make a safe harbor determination, it also recognizes that a registrant may need to obtain a safe harbor determination early in its project's approval process in order to make prudent business decisions about purchasing a site or proceeding to final project designs. The form and instructions for seeking a safe harbor determination are available at www.ct.gov/DEEP/nddbrequest.

Provided the registrant's information is accurate and the Department's Wildlife Division determines that the construction activity will not violate section 3(b)(2) of the GP, the registrant shall receive a safe harbor determination from the Department. A safe harbor determination may indicate that the construction activity will not impact listed species or their associated habitat, or it may include specific conditions to be implemented to avoid or significantly minimize any impacts that may be encountered at the site of the construction activity. The Department shall honor the safe harbor determination for three years from the date it is issued, meaning that unlike the NDDB review in Section 1 or the limited one-year determination in Section 2 of this Appendix, if the Department makes a safe harbor determination and a registrant remains in compliance with any conditions in any such determination, irrespective of what may be found at the site of the construction activity, a registrant shall be considered in compliance with section 3(b)(2) of the GP. However, a safe harbor determination shall not be effective if a construction activity may threaten the continued existence of any federally listed species or its critical habitat under federal law. If a federally listed species or its critical habitat is encountered on the site of the construction activity, the registrant shall promptly contact the Department and may need to take additional action to ensure that the construction activity does not violate federal law or section 3(b)(2) of the GP.

If a registrant receives a safe harbor determination from the Department, the registrant should check the safe harbor determination box on the GP registration form and include the Department's safe harbor determination if requested on the GP Registration form. Checking the safe harbor box on the registration form and failing to provide the safe harbor determination letter from the Department's Wildlife Division, if requested on the GP Registration form, will delay and may prevent processing of a registration.

If based upon the information provided by a registrant seeking a safe harbor determination the Department's Wildlife Division determines that the construction activity could impact listed species or their associated habitat, or that the Department needs additional information to make a safe harbor determination, the registrant may still achieve compliance with section 3(b)(2) of the GP through providing additional information pursuant to Section 4 or developing a mitigation plan pursuant to Section 5 of this Appendix.

If a registrant receives a safe harbor determination from the Department's Wildlife Division, anytime during the third year of such safe harbor, a registrant may request a one-year extension of that safe harbor. If the Department's Wildlife Division has prescribed a form for requesting an extension, any such request shall be made using the prescribed form. There is a presumption that a request for a one-year extension of a safe harbor shall be granted. However, this presumption can be rebutted if the Department determines that a change in any of the following has occurred since the safe harbor was granted: the construction activity affecting or potentially affecting listed species or their associated habitat; the NDDB maps for the site of the construction activity; the information upon which the safe harbor was granted; or other information indicative of a change in circumstance affecting listed species or their associated habitat. A registrant may seek only one extension, for one-year, to a safe harbor determination. Any one-year extension granted under this paragraph shall run from the date of the Department's Wildlife Division issues its determination to grant an extension and shall be honored by the Department in the same manner as a safe harbor determination noted above. Any letter granting a one-year extension shall be included with a registration along with the original limited safe harbor determination as provided for in this section.

Section 4. Providing Additional Information

For the Department's Wildlife Division to make a limited one-year determination under Section 2 or a safe harbor determination under section 3 of this Appendix, limited additional information may be required to determine if the construction activity would impact listed species or their associated habitat. If the species in question is a state listed endangered or threatened species under section 26-306 of the general statutes, a registrant shall, in consultation with the Department's Wildlife Division, provide the limited additional

information requested by the Department's Wildlife Division. Such information may include, but is not limited to, a survey of specific listed species in question. If the species in question is a federally listed threatened or endangered species, in addition to the Department's Wildlife Division, a registrant shall also consult with the U.S. Fish and Wildlife Service and shall provide any additional information requested by that agency. A registrant that initially sought or obtained a limited one-year determination may, after providing the additional information required under this section request a safe harbor determination under Section 3 of this Appendix.

At any time, as an alternative to proceeding under Section 2, 3 or 4 of this Appendix, a registrant may stipulate, in writing, to the presence of one or more listed species or their associated habitat. A registrant choosing this alternative shall proceed to develop a mitigation plan under Section 5 of this Appendix.

If based upon any additional information provided to the Department's Wildlife Division, and as applicable, the U.S. Fish & Wildlife Service, the Department's Wildlife division determines that construction activity will be in compliance with section 3(b)(2) of the GP, a registrant shall receive a limited one-year determination under Section 2 or a safe harbor determination under Section 3 of this Appendix, as applicable.

If the Department's Wildlife Division determines that additional information is necessary to determine if the construction activity has the potential to impact listed species or their associated habitat, and a registrant chooses to not provide such information, a registrant shall proceed with the self assessment through an NDDB review under Section 1 of this Appendix, or stipulate to the existence of a listed species or associated habitat and develop a mitigation plan under Section 5 or such registrant shall not be eligible to register under the GP.

Section 5. Developing a Mitigation Plan

The Department's Wildlife Division may determine that the construction activity has the potential to adversely impact listed species or their associated habitat. However, it may be possible to modify the construction activity or undertake certain on-site measures to avoid or significantly minimize such impacts. If the species or associated habitat in question is a state listed endangered or threatened species under section 26-306 of the general statutes, a registrant shall consult with the Department's Wildlife Division to determine if an acceptable mitigation plan can be developed so impacts can be avoided or minimized such that a registrant remains in compliance with section 3(b)(2). If the species in question is a federally listed threatened or endangered species, any such consultation shall also include the U.S. Fish and Wildlife Service.

If a registrant in consultation with the Department's Wildlife Division, and as applicable, the U.S. Fish & Wildlife Service, develops a mitigation plan that is approved by the Department's Wildlife Division, or as applicable, the U.S. Fish & Wildlife Service, the registrant shall receive a limited one-year determination under Section 2 or a safe harbor determination under Section 3 of this Appendix. In this situation, in addition to checking the one-year determination box or the safe harbor determination box, as applicable, on the registration form, the registrant shall also check the box on the registration form indicating that it has an approved mitigation plan and provide a status update on the registration form as to whether it has completed or is still in the process of implementing the approved mitigation plan.

If an approved mitigation plan has not been fully implemented by the time a registration is submitted, completing all remaining tasks in the plan shall become an enforceable condition of any registration issued to the registrant.

If the Department determines that the construction activity has the potential to adversely impact listed species or their associated habitat and the registrant and the Department, and as applicable, the U.S. Fish & Wildlife Service, are not able to agree on an acceptable mitigation plan that is approved by the Department, and as applicable, the U.S. Fish & Wildlife Service, any such registrant shall not be eligible to register under the GP.

APPENDIX A
ATTACHMENT A

Specific Information Needed to Apply for a Safe Harbor Determination

A Safe Harbor Determination will be made upon the submission of a detailed report that fully addresses the matters noted below. For the Department's Wildlife Division to make a safe harbor determination, the report should synthesize and analyze this information, not simply compile information. Those providing synthesis and analysis need appropriate qualifications and experience. A request for a safe harbor determination shall include:

1) Habitat Information, including GIS mapping overlays, identifying:

- wetlands, including wetland cover types;
- plant community types;
- topography;
- soils;
- bedrock geology;
- floodplains, if any;
- land use history; and
- water quality classifications/criteria.

2) Photographs - The report should also include photographs of the site, including all reasonably available aerial or satellite photographs and an analysis of such photographs.

3) Inspection - The report should include a visual inspection(s) of the site, preferably when the ground is visible. This inspection can also be helpful in confirming or further evaluating the items noted above.

4) Biological Surveys - The report should include all biological surveys of the site where construction activity will take place that are reasonably available to a registrant. A registrant shall notify the Department's Wildlife Division of biological studies of the site where construction activity will take place that a registrant is aware of but are not reasonably available to the registrant.

5) Based on items #1 through 4 above, the report shall include a Natural Resources Inventory of the site of the construction activity. This inventory should also include a review of reasonably available scientific literature and any recommendations for minimizing adverse impacts from the proposed construction activity on listed species or their associated habitat.

6) In addition, to the extent the following is available at the time a safe harbor determination is requested, a request for a safe harbor determination shall include and assess:

- Information on Site Disturbance Estimates/Site Alteration information
- Vehicular Use
- Construction Activity Phasing Schedules, if any; and
- Alternation of Drainage Patterns

General Permit for the Discharge of Stormwater and Dewatering Wastewaters from Construction Activities

APPENDIX B

Connecticut Department of Energy & Environmental Protection Inland Water Resources Division Fact Sheet Considering Low Impact Development Principles in Site Design

In order to reduce the impact of development and address stormwater quality issues, the Department strongly encourages the use of Low Impact Development (LID) measures. LID is a site design strategy intended to maintain or replicate predevelopment hydrology through the use of small-scale controls, integrated throughout the site, to manage stormwater runoff as close to its source as possible. Infiltration of stormwater through LID helps to remove sediments, nutrients, heavy metals, and other types of pollutants from runoff.

Key Strategies for LID

Key strategies for effective LID include: infiltrating, filtering, and storing as much stormwater as feasible, managing stormwater close to where the rain/snow falls, managing stormwater at multiple locations throughout the landscape, conserving and restoring natural vegetation and soils, preserving open space and minimizing land disturbance, designing the site to minimize impervious surfaces, and providing for maintenance and education. Water quality and quantity benefits are maximized when multiple techniques are grouped together. In areas of compacted and/or possibly contaminated soils, soil suitability should be further investigated prior to selecting optimum treatment and/or remediation measures. Where soil conditions permit, the DEEP encourages the utilization of one, or a combination of, the following measures:

- the use of pervious pavement or grid pavers (which are very compatible for parking lot and fire lane applications), or impervious pavement without curbs or with notched curbs to direct runoff to properly designed and installed infiltration areas;
- the use of vegetated swales, tree box filters, and/or infiltration islands to infiltrate and treat stormwater runoff (from building roofs, roads, and parking lots);
- the minimization of access road widths and parking lot areas to the maximum extent possible to reduce the area of impervious surface;
- the use of dry wells to manage runoff from building roofs;
- incorporation of proper physical barriers or operational procedures for special activity areas where pollutants could potentially be released (e.g. loading docks, maintenance and service areas, dumpsters, etc.);
- the installation of rainwater harvesting systems to capture stormwater from building roofs for the purpose of reuse for irrigation (i.e. - rain barrels for residential use and cisterns for larger developments);
- the use of residential rain gardens to manage runoff from roofs and driveways;
- the use of vegetated roofs (green roofs) to detain, absorb, and reduce the volume of roof runoff; and
- providing for pollution prevention measures to reduce the introduction of pollutants to the environment.

The [2004 Stormwater Quality Manual LID Appendix](#) and the [2002 Erosion and Sediment Control Guidelines LID Appendix](#) both provide guidance on implementing LID measures. A guide to LID resources can also be found in the [DEEP Low Impact Development Resources Factsheet](#) (PDF).

LID in Urban Areas

If the proposed site is located in a highly urbanized area, it is likely underlain by urban land complex soils. The Natural Resources Conservation Service (NRCS) Soil Web Survey (<http://websoilsurvey.nrcs.usda.gov/app/HomePage.htm>) provides information on soil textures, parent materials, slopes, height of seasonal high water table, depth to restrictive layer, and permeability. In highly developed areas, infiltration may be limited due to the high percentage of impervious cover. However, infiltration practices may be suitable at urban sites depending on:

- Potential contamination of soils in historically industrialized areas. The siting of areas for infiltration must consider any existing soil or groundwater contamination.
- Site specific soil conditions. NRCS mapping consists of a minimum 3 acres map unit and soils may vary substantially within each mapping unit. Test pits should be dug in areas
- planned for infiltration practices to verify soil suitability and/or limitations.
- Investigation of areas of compacted soils and the utilization of proper construction staging. Planning should insure that areas to be used for infiltration are not compacted during the construction process by vehicles or machinery.

Even if infiltration is limited at a site, it is still possible to implement LID practices. Specifically, potential exists for the installation of green roofs on buildings and/or the use of cisterns to capture and reuse rainwater.

LID in Areas with a High Seasonal Water Table or Hardpan Layer

- The impact of stormwater runoff to any streams and/or wetlands near the site should be considered. Water quality treatment is influenced by hydraulic conductivity and time of travel. If stormwater infiltration is limited by an impermeable layer close to the surface, the water may run laterally through the ground and discharge to the stream or wetlands, providing limited water quality treatment. However, a longer time of travel may provide sufficient treatment. Proper soil testing for infiltration potential will increase the likelihood of successful BMP design.
- In areas with a high seasonal water table, bioretention areas/rain gardens should be planted with water tolerant/wetland plants. The presence of a high seasonal water table suggests that water may drain slowly or not at all during certain parts of the year. Planting native wetland vegetation will help to ensure plant survival and increase the effectiveness of bioretention practices. Information on native plantings that are both drought tolerant and tolerant of wet conditions can be found in The UConn Cooperative Extension System's guide to building a rain garden at http://nemo.uconn.edu/publications/rain_garden_broch.pdf. Native plant lists for Connecticut can also be found at <http://www.fhwa.dot.gov/environment/rdsduse/ct.htm>.

LID Guidance for Federal Projects

- LID techniques have been utilized by Department of Defense (DoD) agencies during the last several years. The effectiveness of these projects in managing runoff as well as reducing construction and maintenance costs has created significant interest in LID. The DoD has created a Unified Facilities Criteria document, Low Impact Development that provides guidelines for integrating LID planning and design into a facility's regulatory and resource protection programs. It is available on-line at: http://www.wbdg.org/ccb/DOD/UFC/ufc_3_210_10.pdf.
- Section 438 of the Energy Independence and Security Act (EISA) of 2007 requires federal agencies to reduce stormwater runoff from federal development projects to protect water resources. In December 2009, the EPA developed a technical guidance document on implementing the stormwater runoff requirements for federal projects under Section 438 of EISA. The document contains guidance on how compliance with Section 438 can be achieved, measured and evaluated and can be found at: http://www.epa.gov/owow/NPS/lid/section438/pdf/final_sec438_eisa.pdf.

For more information contact the CT DEEP Watershed Management/Low Impact Development Program:

Name	Area	Telephone
MaryAnn Nusom Haverstock	Program Oversight/ Low Impact Development	(860) 424-3347
Chris Malik	Watershed Manager	(860) 424-3959
Susan Peterson	Watershed Manager	(860) 424-3854
Eric Thomas	Watershed Manager	(860) 424-3548

List of Runoff Reduction/LID Practices

Re-Forestation
Disconnection of Rooftop Runoff
Disconnection of Non-Rooftop Runoff
Sheetflow to Conservation Areas
Green Roof
Permeable Pavement
Rainwater Harvesting
Submerged Gravel Wetlands
Micro-Infiltration
Rain Gardens
Bioretention
Landscape Infiltration
Grass Swales
Bio-swales
Wet Swales
Stormwater Ponds
Stormwater Wetlands
Stormwater Filtering Systems
Stormwater Infiltration



General Permit for the Discharge of Stormwater and Dewatering Wastewaters from Construction Activities

APPENDIX C

AQUIFER PROTECTION AREAS AND OTHER GROUNDWATER DRINKING SUPPLY AREAS GUIDANCE INFORMATION

The Pollution Control Plan (“the Plan”) should consider measures to reduce or mitigate potential impacts to both ground water (aquifers) and surface waters, taking into consideration both quantity and quality of the runoff. The emphasis should be to minimize, to the extent possible, changes between pre-development and post-development runoff rates and volumes.

The basic stormwater principals for Aquifer Protection Areas (and other groundwater drinking supply areas) are to prevent inadvertent pollution discharges/releases to the ground, while encouraging recharge of stormwater where it does not endanger groundwater quality. Measures include:

- prevent illicit discharges to storm water, including fuel/chemical pollution releases to the ground;
- minimize impervious coverage and disconnect large impervious areas with natural or landscape areas;
- direct paved surface runoff to aboveground type land treatment structures – sheet flow, surface swales, depressed grass islands, detention/retention and infiltration basins, and wet basins. These provide an opportunity for volatilization of volatile organic compounds to the extent possible before the stormwater can infiltrate into the ground;
- provide necessary impervious pavement in high potential pollutant release areas. These “storm water hot spots” include certain land use types or storage and loading areas, fueling areas, intensive parking areas and roadways (see table below);
- only use subsurface recharge structures such as dry wells, galleries, or leaching trenches, to directly infiltrate clean runoff such as rooftops, or other clean surfaces. These structures do not adequately allow for attenuation of salts, solvents, fuels or other soluble compounds in groundwater that may be contained in runoff; and
- restrict pavement deicing chemicals, or use an environmentally suitable substitute such as sand only, or alternative de-icing agents such as calcium chloride or calcium magnesium.

Infiltration of stormwater should be **restricted** under the following site conditions:

- **Land Uses or Activities with Potential for Higher Pollutant Loads:** Infiltration of stormwater from these land uses or activities (refer to Table 7-5 below), also referred to as stormwater “hotspots,” can contaminate public and private groundwater supplies. Infiltration of stormwater from these land uses or activities may be allowed by the review authority with appropriate pretreatment. Pretreatment could consist of one or a combination of the primary or secondary treatment practices described in the Stormwater Quality Manual provided that the treatment practice is designed to remove the stormwater contaminants of concern.
- **Subsurface Contamination:** Infiltration of stormwater in areas with soil or groundwater contamination such as brownfield sites and urban redevelopment areas can mobilize contaminants.
- **Groundwater Supply and Wellhead Areas:** Infiltration of stormwater can potentially contaminate groundwater drinking water supplies in immediate public drinking water wellhead areas.

Land Uses or Activities with Potential for Higher Pollutant Loads
 Table 7-5 of the 2004 Stormwater Quality Manual

<u>Land Use/Activities</u>	
<ul style="list-style-type: none"> • Industrial facilities subject to the DEEP Industrial Stormwater General Permit or the U.S. EPA National Pollution Discharge Elimination System (NPDES) Stormwater Permit Program • Vehicle salvage yards and recycling facilities • Vehicle fueling facilities (gas stations and other facilities with on-site vehicle fueling) • Vehicle service, maintenance, and equipment cleaning facilities • Fleet storage areas (cars, buses, trucks, public works) • Commercial parking lots with high intensity use (shopping malls, fast food restaurants, convenience stores, supermarkets, etc.) • Public works storage areas 	<ul style="list-style-type: none"> • Road salt storage facilities (if exposed to rainfall) • Commercial nurseries • Flat metal rooftops of industrial facilities • Facilities with outdoor storage and loading/unloading of hazardous substances or materials, regardless of the primary land use of the facility or development • Facilities subject to chemical inventory reporting under Section 312 of the Superfund Amendments and Reauthorization Act of 1986 (SARA), if materials or containers are exposed to rainfall • Marinas (service and maintenance) • Other land uses and activities as designated by the review authority

For further information regarding the design of stormwater collection systems in Aquifer Protection Areas, contact the Aquifer Protection Area Program at (860) 424-3020 or visit www.ct.gov/deep/aquiferprotection.



**General Permit for the Discharge of Stormwater and Dewatering Wastewaters
from Construction Activities**

APPENDIX D

Coastal Management Act Determination Form

For sites within the Coastal Boundary, please attach this form and written approval from the local governing authority (or verification of exemption) to the Registration Form for the Discharge of Stormwater and Dewatering Wastewaters From Construction Activities.

SITE INFORMATION

Future Permittee _____
Mailing Address _____
Business Phone _____ ext.: _____ Fax: _____
Contact Person _____ Title: _____
Site Name _____
Site Address/ Location _____
Site Latitude and Longitude _____
Receiving Water (name, basin) _____
Project Description _____

STATEMENT OF REVIEW:

<p>The above referenced project is consistent with the goals and policies in section 22a-92 of the Connecticut General Statutes and will not cause adverse impacts to coastal resources as defined in section 22a-93(15) of the Connecticut General Statutes.</p> <p>Date of Coastal Site Plan Approval: _____</p> <p><input type="checkbox"/> Copy of written approval attached, or</p> <p><input type="checkbox"/> Verification of exemption attached</p>

APPENDIX E
(Exhibit 3 of District/DEEP Memorandum of Agreement)

Conservation Districts of Connecticut
Regional Delineations and Contact Information

Northwest Conservation District
1185 New Litchfield Street
Torrington, CT 06790
Ph: 860-626-7222
Fax: 860-626-7222
Email: ncd@conservect.org

Eastern Connecticut Conservation District
238 West Town Street
Norwich, CT 06360-2111
Ph: 860-887-4163 x 400 Fax: 860-887-4082
Email: kate.johnson.eccd@comcast.net

Connecticut River Coastal Conservation District, Inc.
deKoven House Community Center
27 Washington Street
Middletown, CT 06457
Ph: 860-346-3282 Fax: 860-346-3284
Email: ctrivercoastal@conservect.org

Southwest Conservation District
51 Mill Pond Road
Hamden, CT 06514
Ph: 203-287-8179 Fax: 203-288-5077
Email: swcd43@sbcglobal.net

North Central Conservation District
24 Hyde Avenue
Vernon, CT 06066
Ph: 860-875-3881 Fax: 860-870-8973
Email: tollandc@snet.net

NORTHWEST	SOUTHWEST	NORTH CENTRAL	CT RIVER COASTAL	EASTERN
Barkhamsted	Ansonia	Avon	Berlin	Andover
Bethel	Beacon Falls	Bloomfield	Chester	Ashford
Bethlehem	Bethany	Bolton	Clinton	Bozrah
Bridgewater	Branford	Bristol	Colchester	Brooklyn
Brookfield	Bridgeport	Burlington	Cromwell	Canterbury
Canaan	Cheshire	Canton	Deep River	Chaplin
Colebrook	Darien	Coventry	Durham	Columbia
Cornwall	Derby	East Granby	East Haddam	Eastford
Danbury	East Haven	East Hartford	East Hampton	East Lyme
Goshen	Easton	East Windsor	Essex	Franklin
Hartland	Fairfield	Ellington	Haddam	Griswold
Harwinton	Greenwich	Enfield	Hebron	Groton
Kent	Guilford	Farmington	Killingworth	Hampton
Litchfield	Hamden	Glastonbury	Lyme	Killingly
Morris	Meriden	Granby	Madison	Lebanon
New Fairfield	Middlebury	Hartford	Marlborough	Ledyard
New Hartford	Milford	Manchester	Middlefield	Lisbon
New Milford	Monroe	Plainville	Middletown	Mansfield
Newtown	Naugatuck	Simsbury	Newington	Montville
Norfolk	New Canaan	Somers	New Britain	New
North Canaan	New Haven	South Windsor	Old Lyme	London
Plymouth	North Branford	Stafford	Old Saybrook	North
Roxbury	North Haven	Suffield	Portland	Stonington
Salisbury	Norwalk	Tolland	Rocky Hill	Norwich
Sharon	Orange	Vernon	Salem	Plainfield
Sherman	Oxford	West Hartford	Westbrook	Pomfret
Southbury	Prospect	Wethersfield		Preston
Thomaston	Redding	Willington		Putnam
Torrington	Ridgefield	Windsor		Scotland
Warren	Seymour	Windsor Locks		Sprague
Washington	Shelton			Sterling
Watertown	Southington			Stonington
Winchester	Stamford			Thompson
Woodbury	Stratford			Union
	Trumbull			Voluntown
	Wallingford			Waterford
	Waterbury			Windham
	West Haven			Woodstock
	Weston			
	Westport			
	Wilton			
	Wolcott			
	Woodbridge			

APPENDIX F

Memorandum of Agreement Between The Connecticut Department of Energy & Environmental Protection and the Conservation Districts of Connecticut

WHEREAS, the Commissioner of the Department of Energy and Environmental Protection (“Department” or “DEEP”) is authorized by section 22a-6(2)(3) and (4) of the Connecticut General Statutes (“CGS”) to enter into this Agreement; and

WHEREAS, the five Conservation Districts of Connecticut (collectively, the “Districts”), are not-for-profit corporations duly authorized, organized and existing under the laws of the State of Connecticut and are authorized by section 22a-315 of the CGS and section 22a-315-14 of the Regulations of Connecticut State Agencies to enter into this Agreement; and

WHEREAS, section 22a-430b of the Connecticut General Statutes requires the Department to regulate stormwater discharges from construction activities under the General Permit for the Discharge of Stormwater and Dewatering Wastewaters Associated with Construction Activities (“the Construction General Permit” or “CGP”), which has been or shall be issued on October 1, 2013. The Construction General Permit requires the implementation of erosion and sedimentation controls to control the discharge of sediment from construction and post-construction discharges; and

WHEREAS, Construction General Permits require the preparation and implementation of a Stormwater Pollution Control Plan (“Plan” or “SWPCP”) to prevent erosion and the discharge of sediment to the waters of the state; and

WHEREAS, pursuant to section 22a-315 of the CGS, soil and water conservation districts and boards were established to advise the Commissioner on matters of soil and water conservation and erosion and sedimentation control and to assist the Commissioner in implementing programs related to soil and water conservation and erosion and sediment control; and

WHEREAS, pursuant to section 22a-315 of the CGS, the soil and water conservation districts and boards may receive funds from private sources for services provided to promote soil and water conservation and to assist the Commissioner in the implementation of related programs; and

WHEREAS, section 22a-326 of the CGS declares the policy of the state “to strengthen and extend its erosion and sediment control activities and programs and to establish and implement, through the Council on Soil and Water Conservation, soil and water conservation districts, the municipalities and the Commissioner of Energy and Environmental Protection, a state-wide coordinated erosion and sediment control program which shall reduce the danger from storm water runoff, minimize nonpoint sediment pollution from land being developed and conserve and protect the land, water, air and other environmental resources of the state;” and

WHEREAS, the Districts have understanding and experience in reviewing erosion and sediment control plans because of their longstanding participation in the municipal approval process, as required by section 22a-329 of the CGS; and

WHEREAS, DEEP and the Districts are jointly dedicated to protecting the waters of the state by controlling the discharge of sediment and the pollution resulting from stormwater runoff.

NOW, THEREFORE, in consideration of the mutual covenants and conditions hereinafter stated, the Parties agree as follows:

I. RESPONSIBILITIES OF THE CONSERVATION DISTRICTS.

For locally approvable projects, as defined in the Construction General Permit, with five (5) or more acres of soil disturbance, the appropriate District (as specified in Appendix E of the Construction General Permit, appended hereto as Exhibit 3) shall review Stormwater Pollution Control Plans submitted to the District in accordance with Section 3(b)(10) of the CGP, shall determine whether each such SWPCP is consistent with the requirements of the CGP, and shall advise the Commissioner in writing of its determination regarding the SWPCP's consistency.

A. Components of the SWPCP Review by the Districts

1. Requirements for Conducting a Review:

(a) SWPCP review shall be conducted by a District representative having one or more of the following minimum qualifications: (i) a bachelor's degree in hydrology, engineering (agricultural, civil, environmental, or chemical), landscape architecture, geology, soil science, environmental science, natural resources management, or a related field and two years of professional and field experience, or (ii) the EnviroCert International, Inc. designation as a Certified Professional in Erosion and Sediment Control, or a Certified Professional in Storm Water Quality.

(b) All SWPCP reviews undertaken by a District shall be conducted in accordance with the guidelines and procedures established by DEEP in consultation with the Districts, as further described below, and shall include at least one inspection, and no more than 3 inspections, of the project site.

(c) The District shall begin a SWPCP review upon the receipt of the all of following: the developer's request for review, two copies of the proposed SWPCP, the payment of required fee in the amount specified in Exhibit 1 and the written permission of the developer to enter onto and inspect the project site. Once the District is in receipt of all the documents and the fee as delineated above, the developer's SWPCP shall be considered submitted to the District.

2. Determinations of Consistency by the District after Review of the SWPCP and Subsequent Procedures

(a) If the District determines the developer's SWPCP is:

(i) Consistent with the requirements of the Construction General Permit, the District shall issue an affirmative determination notice to both the developer or such developer's designee and to DEEP in order to advise them of the adequacy of the SWPCP. The District shall also provide a copy of the SWPCP to DEEP if requested by the Commissioner.

(ii) Not consistent with the requirements of the Construction General Permit, the District shall provide a written notice of such inconsistency to the developer or such developer's designee; such notice shall include a list of the SWPCP's deficiencies and any appropriate explanatory comments.

(b) If the developer's SWPCP is found to be inconsistent with the CGP, the developer may revise the SWPCP (the "Revised SWPCP") to address any deficiencies noted by the District and resubmit its Revised SWPCP to the District for review.

(c) If the District receives a Revised SWPCP in accordance with subsection (b) above, the District shall perform a review of the Revised SWPCP. If the Revised SWPCP is deemed:

(i) Consistent with the requirements of the Construction General Permit, the District shall (1) issue an affirmative determination notice to both the project developer or such project developer's designee and to DEEP to advise them of the adequacy of the SWPCP and (2) provide a copy of the SWPCP to the DEEP if requested by the Commissioner; or

(ii) Not consistent with the requirements of the CGP after this review, the District shall provide a written notice of such inconsistency to the developer or such developer's designee. This notice shall include a list of all remaining SWPCP deficiencies and any explanatory comments as appropriate.

(d) In the event the District determines after review of the Revised SWPCP in accordance with subsection (c), above, that the Revised SWPCP remains inconsistent with the requirements of the Construction General Permit, and the developer resubmits its Revised SWPCP *within 180 calendar days* of the District's original determination of inconsistency, the resubmitted Revised SWPCP shall be considered a Resubmission. As such, the resubmitted Revised SWPCP shall be reviewed by the District in accordance with the timeframes set forth in Section I.B., and other applicable sections of this document, and the fee shall be in accordance with Section II, below, and the Resubmission Fee in Exhibit 1.

(e) In the event the District determines after review of the Revised SWPCP in accordance with subsection (c), above, that the Revised SWPCP remains inconsistent with the requirements of the Construction General Permit, and the developer resubmits its Revised SWPCP *more than 180 calendar days after* the District's original determination of inconsistency, the resubmitted Revised SWPCP shall be considered a new submission. The newly submitted Revised SWPCP shall be reviewed by the District in accordance with the timeframes set forth in Section I.B., and other applicable sections of this document, and the fee shall be in accordance with Section II, below, and the SWPCP Review Fee in Exhibit 1.

(f) Revisions to a SWPCP subsequent to the District's prior approval of developer's SWPCP

(i) In the event the developer revises a SWPCP after the District has determined that the developer's SWPCP, prior to this revision, was consistent with the requirements of the Construction General Permit, and the developer submits the revised SWPCP to the District for review *within 180 calendar days* of the District's original determination of consistency, the SWPCP shall be considered a Post-Approval Resubmission. As a Post-Approval Resubmission, the SWPCP shall be reviewed by the District in accordance with the timeframes set forth in Section I.B., and other applicable sections of this document, and the fee shall be in accordance with Section II, below, and the Post-Approval Resubmission Fee in Exhibit 1.

(ii) In the event the developer revises a SWPCP after the District has determined that the developer's SWPCP, prior to this revision, was consistent with the requirements of the Construction General Permit, and the developer submits the revised SWPCP to the District for review *more than 180 calendar days after* the District's original determination of consistency, the SWPCP shall be considered a new submission. The newly submitted SWPCP shall be reviewed by the District in accordance with the timeframes set forth in Section I.B., and other applicable sections of this document, and the fee shall be in accordance with Section II, below, and the SWPCP Review Fee in Exhibit 1.

B. Plan Review Timeframes

1. The District shall review a new submission of a SWPCP submitted by a developer or such developer's designee and provide review comments within thirty (30) calendar days of the date of a complete submission as specified in Section I.A.1.(c).
2. If the District identifies deficiencies in the SWPCP, the District shall allow the developer or such developer's designee the opportunity to revise their SWPCP and resubmit it to the District within fifteen (15) calendar days after the date of mailing or delivery of the District's written comments to the developer or such developer's designee.
3. The District shall review any SWPCP revised in accordance with subsection I.B.2., above, and provide a written determination of the SWPCP's consistency or inconsistency within fifteen (15) calendar days after the submission of the revised SWPCP.
4. At the request of the District or the developer and with the agreement of both the District and the developer, the deadlines stated in subsections 1. – 3., above, may be extended. However, any such extensions shall be limited to no more than double the original amount of time allowed above for the relevant action.
5. Express review of a SWPCP may be requested by a developer. However, the Districts shall have complete discretion to accept or decline such request for an express review based on the District's circumstances, including, but not limited to: their existing workload, vacation schedules and staffing. If a District grants an express review, the timeframe shall be reduced to no more than one third of the timeframes noted in subsection 1. – 3., above, and the fee shall be in accordance with the Express Reviews fee in Exhibit 1.
6. In the event a District does not complete the review of the SWPCP within sixty (60) days (or within the time allowed under any authorized extension pursuant to subsection B.4, above, but in no circumstance later than 120 days) of the date the SWPCP was initially submitted to the District, and provided such delay is not the result of the developer's or such developer's designee's failure to address SWPCP deficiencies as noted in subsection B.2, above, the District shall:
 - (a) not later than three (3) days after the District's deadline, notify the DEEP that the developer shall be initiating the registration process for the Construction General Permit in accordance with section I.B of this Agreement, for completion of the SWPCP review, and;
 - (b) provide to the DEEP, upon request, the District's complete file, including supporting documentation the developer's SWPCP consistency determination, including, but not limited to, the SWPCP, any other documentation submitted to the District by or on behalf of a developer, and any analysis already performed by the District; and
 - (c) not later than seven (7) days after the District's deadline, in accordance with section I.B of this Agreement, for completion of the SWPCP review, transfer to the DEEP, up to a maximum of \$4,500, the fees that were originally submitted by the developer.

C. Inspections of the Project Site

1. Prior to the commencement of project construction and during the course of the SWPCP review process, the District shall conduct at least one inspection of the project site.
2. Once the construction of the project has begun, a District shall make at least one, but not more than three, inspection(s) of the project site to verify that the developer's SWPCP is being

implemented as approved by the District. A District shall report the results of the inspection(s) to the developer or such developer's designee and to DEEP in a manner prescribed by the Commissioner.

3. Upon notification from the developer or developer's designee, in accordance with Section 6(a)(1) of the CGP, that construction of the stormwater collection and management system is complete, the District shall conduct one inspection of the project site to verify that the post-construction stormwater management measures were completed in accordance with the approved SWPCP. The District shall report the results of this inspection to DEEP in a manner prescribed by the Commissioner.

D. Audits

The District agrees that all records pertaining to this Agreement shall be maintained for a period of not less than five (5) years. Such records shall be made available to the DEEP and to the state auditors upon request. For the purposes of this Agreement, "Records" are all working papers and such information and materials as may have been accumulated by the District in performing the Agreement, including, but not limited to, documents, data, analysis, plans, books, computations, drawings, specifications, notes, reports, records, estimates, summaries and correspondence, kept or stored in any form.

II. FEE SCHEDULE.

A. A District may assess fees for the services it renders in conjunction with its SWPCP reviews. Such fees shall be paid as follows:

1. All fees, except those described in subsection II.A.2, below, shall be submitted by the developer to the District with the developer's request for review. These fees are non refundable.
2. The fee for Post-Approval Resubmission, as designated in Exhibit 1, shall be submitted by the developer to the District upon completion of the District's review, prior to release of the determination notice, and is non refundable.

B. The Fee Schedule shall be reviewed annually by the Parties. The Fee Schedule may be adjusted as warranted, without a formal amendment to this Agreement, by mutual agreement between the Districts and the Commissioner.

III. RESPONSIBILITIES OF DEEP.

A. In accordance with the Construction General Permit requirements for SWPCP reviews by a third party, DEEP shall conduct outreach to inform the development community that a District may review SWPCPs for consistency with the requirements of the Construction General Permit. DEEP shall also inform the development community that a registration form for authorization under the Construction General Permit may only be submitted to DEEP if: the District, or other third party in accordance with Section 3(b)(11) of the CGP, determines that the SWPCP is consistent with the requirements of the CGP, or in the event the time schedule is exceeded for a District review as described in section I.B.6, above.

B. In order to institute standard SWPCP review guidelines and procedures, DEEP shall coordinate with the Districts to prepare a SWPCP checklist. The standard review guidelines and procedures established shall be consistent with the requirements of the Construction General Permit, the 2002 CT Guidelines for Soil Erosion and Sedimentation Control, and the 2004 Stormwater Quality Manual. The Commissioner shall have final approval of the review guidelines and procedures.

C. DEEP shall provide initial training regarding SWPCP requirements for District staff involved in SWPCP reviews. The frequency of subsequent training shall be determined by the Commissioner.

D. DEEP shall retain final decision making authority regarding the determination that a SWPCP is or is not consistent with the requirements of the Construction General Permit and shall oversee the permitting process for Construction General Permit coverage.

E. Once a SWPCP has been approved, DEEP shall oversee any subsequent compliance and/or enforcement matters related to a developer's adherence to the requirements of the Construction General Permit.

F. DEEP shall have the discretion to review any of the Districts' records pertaining to any aspect this Agreement.

IV. POINTS OF CONTACT.

The following shall be points of contact for this Agreement unless otherwise agreed to by all Parties, notwithstanding section VI. All notices, demands, requests, consents, approvals or other communications required or permitted to be given or which are given with respect to this Agreement (for the purpose of this section collectively called "Notices") shall be deemed to have been effected at such time as the notice is placed in the U.S. mail, first class and postage prepaid, return receipt requested, or, placed with a recognized, overnight express delivery service that provides for a return receipt. All such Notices shall be in writing and shall be addressed as follows:

A. DEEP

Director
Water Permitting & Enforcement Division
Bureau of Material Management & Compliance Assurance
Department of Energy & Environmental Protection
79 Elm St.
Hartford, CT 06106
Phone: 860-424-3018
Fax: 860-424-4074

B. Conservation District

Board Chairperson
Address & Phone of appropriate District:

Northwest Conservation District
1185 New Litchfield Street
Torrington, CT 06790
Ph: 860-626-7222
Fax: 860-626-7222
Email: ncd@conservect.org

Eastern Connecticut Conservation District
238 West Town Street
Norwich, CT 06360-2111
Ph: 860-887-4163 x 400 Fax: 860-887-4082
Email: kate.johnson.eccd@comcast.net

Connecticut River Coastal Conservation District, Inc.
deKoven House Community Center
27 Washington Street
Middletown, CT 06457
Ph: 860-346-3282 Fax 860-346-3284
Email: ctrivercoastal@conservect.org

Southwest Conservation District
51 Mill Pond Road
Hamden, CT 06514
Ph: 203-287-8179 Fax: 203-288-5077
Email: swcd43@sbcglobal.net

North Central Conservation District
24 Hyde Avenue
Vernon, CT 06066
Ph: 860-875-3881 Fax: 860-870-8973
Email: tollandc@snet.net

V. EXECUTIVE ORDERS AND ANTI-DISCRIMINATION. The Districts shall comply with the additional terms and conditions hereto attached as Exhibit 2.

VI. AMENDMENTS. Either the DEEP or the Districts may recommend revisions to this Agreement as circumstances may warrant; however, any revisions must be upon mutual agreement of DEEP and all five Conservation Districts. Unless otherwise stated in this Agreement, formal written amendment is required for changes to any of the terms and conditions specifically stated in the Agreement, including Exhibit 2 of the Agreement, any prior amendments to the Agreement, and any other Agreement revisions determined material by the Department.

VII. SEVERABILITY. The provisions of this Agreement are severable. If any part of it is found unenforceable, all other provisions shall remain fully valid and enforceable, unless the unenforceable provision is an essential element of the bargain.

VIII. SOVEREIGN IMMUNITY. The Parties acknowledge and agree that nothing in the Agreement shall be construed as a modification, compromise or waiver by the State of any rights or defenses of any immunities provided by federal law or the laws of the State of Connecticut to the State or any of the State's, which they may have had, now have or shall have with respect to all matters arising out of the Agreement. To the extent that this section conflicts with any other section, this section shall govern.

IX. FORUM AND CHOICE OF LAW. The Agreement shall be deemed to have been made in the City of Hartford, State of Connecticut. Both Parties agree that it is fair and reasonable for the validity and construction of the Agreement to be, and it shall be, governed by the laws and court decisions of the State of Connecticut, without giving effect to its principles of conflicts of laws. To the extent that any immunities provided by federal law or the laws of the State of Connecticut do not bar an action against the State or the Districts, and to the extent that these courts are courts of competent jurisdiction, for the purpose of venue, the complaint shall be made returnable to the Judicial District of Hartford only or shall be brought in the United States District Court for the District of Connecticut only, and shall not be transferred to any other court, provided, however, that nothing here constitutes a waiver or compromise of the sovereign immunity of the State of Connecticut. The Districts waive any objection which they may now have or shall have to the laying of venue of any Claims in any forum and further irrevocably submits to such jurisdiction in any suit, action or proceeding.

X. TERMINATION. Notwithstanding any provisions in this Agreement, DEEP, through a duly

authorized employee, may terminate the Agreement whenever the Agency makes a written determination that such Termination is in the best interests of the State. The Agency shall notify the Districts in writing sent by certified mail, return receipt requested, which notice shall specify the effective date of Termination and the extent to which the Districts must complete its Performance under the Agreement prior to such date; or (b) The Districts may terminate the Agreement for good cause. The Districts shall notify DEEP by written notice at least one hundred eighty (180) days prior to the effective date of termination. In order for the Districts to terminate this Agreement, (1) there must be a consensus between all five Conservation Districts that each District shall be terminating this Agreement with the DEEP; (2) such proof of consensus shall be submitted to the DEEP in the form of a letter signed by the duly authorized agent for each District by certified mail, return receipt requested, at least one hundred eighty (180) days prior to the Districts' intention to cancel or terminate. Upon the Termination of this Agreement by either Party, the Districts shall deliver to the Agency copies of all Records no later than thirty (30) days after the Termination of the Agreement, or fifteen (15) days after the Non-terminating Party receives a written request from the Terminating Party for the Records. The Districts shall deliver those Records that exist in electronic, magnetic or other intangible form in a non-proprietary format, such as, but not limited to, PDF, ASCII or .TXT. Upon receipt of a written notice of Termination from the Agency, the Districts shall cease operations as the Agency directs in the notice, and take all actions that are necessary or appropriate, or that the Agency may reasonably direct, for the protection, and preservation of records. Except for any work which the Agency directs the Districts to Perform in the notice prior to the effective date of Termination, and except as otherwise provided in the notice, the Districts shall terminate or conclude all existing subcontracts and purchase orders and shall not enter into any further subcontracts, purchase orders or commitments. Upon Termination of the Agreement, all rights and obligations shall be null and void, so that no Party shall have any further rights or obligations to any other Party, except with respect to the sections which survive Termination. All representations, warranties, agreements and rights of the Parties under the Agreement shall survive such Termination to the extent not otherwise limited in the Agreement and without each one of them having to be specifically mentioned in the Agreement. Termination of the Agreement pursuant to this section shall not be deemed to be a breach of Agreement by the Agency.

XI. DURATION OF AGREEMENT. This Agreement shall be effective on July 1, 2013 or on the date of the last signature below, whichever is later, and shall continue in force unless canceled or terminated by either party in accordance with paragraph X above.

XII. VOID AB INITIO. Notwithstanding paragraphs X and XI, the Agreement shall be void *ab initio* if the Construction General Permit is reissued, revoked or modified to eliminate the need for the Districts to review the SWPCP pursuant to such general permit's terms and conditions or if the Construction General Permit expires and is not reissued.

XIII. INTERPRETATION. The Agreement contains numerous references to statutes and regulations. For purposes of interpretation, conflict resolution and otherwise, the content of those statutes and regulations shall govern over the content of the reference in the Agreement to those statutes and regulations.

XIV. ENTIRETY OF AGREEMENT. This Agreement is the entire agreement between the Parties with respect to its subject matter, and supersedes all prior agreements, proposals, offers, counteroffers and understandings of the Parties, whether written or oral. The Agreement has been entered into after full investigation, neither Party relying upon any statement or representation by the other unless such statement or representation is specifically embodied in the Agreement.

XV. PROTECTION OF STATE CONFIDENTIAL INFORMATION. *(mandatory language required for all PSAs effective 12/1/11)*

A. The Districts or District Parties, at their own expense, have a duty to and shall protect from a

Confidential Information Breach any and all Confidential Information which they come to possess or control, wherever and however stored or maintained, in a commercially reasonable manner in accordance with current industry standards.

B. Each District or District Party shall develop, implement and maintain a comprehensive data-security program for the protection of Confidential Information. The safeguards contained in such program shall be consistent with and comply with the safeguards for protection of Confidential Information, and information of a similar character, as set forth in all applicable federal and state law and written policy of the Department or State concerning the confidentiality of Confidential Information. Such data-security program shall include, but not be limited to, the following:

1. A security policy for employees related to the storage, access and transportation of data containing Confidential Information;
2. Reasonable restrictions on access to records containing Confidential Information, including access to any locked storage where such records are kept;
3. A process for reviewing policies and security measures at least annually;
4. Creating secure access controls to Confidential Information, including but not limited to passwords; and
5. Encrypting of Confidential Information that is stored on laptops, portable devices or being transmitted electronically.

C. The District and District Parties shall notify the Department and the Connecticut Office of the Attorney General as soon as practical, but no later than twenty-four (24) hours, after they become aware of or suspect that any Confidential Information which Parties have come to possess or control has been subject to a Confidential Information Breach. If a Confidential Information Breach has occurred, the District shall, within three (3) business days after the notification, present a credit monitoring and protection plan to the Commissioner of Administrative Services, the Department and the Connecticut Office of the Attorney General, for review and approval. Such credit monitoring or protection plan shall be made available by the District at its own cost and expense to all individuals affected by the Confidential Information Breach. Such credit monitoring or protection plan shall include, but is not limited to, reimbursement for the cost of placing and lifting one (1) security freeze per credit file pursuant to Connecticut General Statutes §36a-701a. Such credit monitoring or protection plans shall be approved by the State in accordance with this Section and shall cover a length of time commensurate with the circumstances of the Confidential Information Breach. The District's costs and expenses for the credit monitoring and protection plan shall not be recoverable from the Department, any State of Connecticut entity or any affected individuals.

D. The District shall incorporate the requirements of this Section in all subAgreements requiring each District Party to safeguard Confidential Information in the same manner as provided for in this Section.

E. Nothing in this Section shall supersede in any manner the District's and/ or the District Parties' obligations pursuant to HIPAA or the provisions of this Agreement concerning the obligations of the District as a Business Associate of the Department.

XVI. AMERICANS WITH DISABILITIES ACT (*Mandatory*). The Districts shall be and remain in compliance with the Americans with Disabilities Act of 1990 ("Act"), to the extent applicable, during the term of the Agreement. The DEEP may cancel the Agreement if the District and District Parties fail to comply with the Act.

XVII. ADA PUBLICATION STATEMENT. The following statement shall be incorporated into all **publications** prepared under the terms of this Agreement:

“The Department of Energy and Environmental Protection is an affirmative action/equal opportunity employer and service provider. In conformance with the Americans with Disabilities Act, DEEP makes every effort to provide equally effective services for persons with disabilities. Individuals with disabilities who need this information in an alternative format, to allow them to benefit and/or participate in the agency’s programs and services, should call DEEP’s Human Resources Office at (860) 424-3006, send a fax to (860) 424-3896, or email DEEP.MedRecs@ct.gov. Persons who are hearing impaired should call the State of Connecticut relay number 711.”

When advertising any **public meetings** conducted under the terms of this Agreement, the above publications language should be used as well as the following statement:

“Requests for accommodations must be made at least two weeks prior to the program date.”

All **videos** produced under the terms of this Agreement must be made available with closed captioning.

XVIII. PUBLICATION OF MATERIALS. The District must obtain written approval from the State of Connecticut prior to distribution or publication of any printed material prepared under the terms of this Agreement. Unless specifically authorized in writing by the State, on a case by case basis, the District shall have no right to use, and shall not use, the name of the State of Connecticut, its officials, agencies, or employees or the seal of the State of Connecticut or its agencies: (1) in any advertising, publicity, promotion; or (2) to express or to imply any endorsement of District’s products or services; or (3) to use the name of the State of Connecticut, its officials agencies, or employees or the seal of the State of Connecticut or its agencies in any other manner (whether or not similar to uses prohibited by (1) and (2) above), except only to manufacture and deliver in accordance with this Agreement such items as are hereby contracted for by the State. In no event may the Districts use the State Seal in any way without the express written consent of the Secretary of State.

XIX. CHANGES IN PRINCIPAL PROJECT STAFF. Any changes in the principal project staff must be requested in writing and approved in writing by the Commissioner at the Commissioner’s sole discretion. In the event of any unapproved change in principal project staff, the Commissioner may, in the Commissioner’s sole discretion, terminate this Agreement.

XX. FURTHER ASSURANCES. The Parties shall provide such information, execute and deliver any instruments and documents and take such other actions as may be necessary or reasonably requested by the other Party which are not inconsistent with the provisions of this Agreement and which do not involve the vesting of rights or assumption of obligations other than those provided for in the Agreement, in order to give full effect to the Agreement and to carry out the intent of the Agreement.

XXI. ASSIGNMENT. The Districts shall not assign any of their rights or obligations under the Agreement, voluntarily or otherwise, in any manner without the prior written consent of the Agency. The Agency may void any purported assignment in violation of this section and declare the District in breach of this Agreement. Any termination by the Agency for a breach is without prejudice to the Agency’s or the State’s rights or possible Claims.

XXII. EXHIBITS. All exhibits referred to in, and attached to, this Agreement are incorporated in this Agreement by such reference and shall be deemed to be a part of it as if they had been fully set forth in it.

XXIII. FORCE MAJEUR. Events that materially affect the cost of the Goods or Services or the time schedule within which to Perform and are outside the control of the party asserting that such an event has

occurred, including, but not limited to, labor troubles unrelated to District(s), failure of or inadequate permanent power, unavoidable casualties, fire not caused by a District, extraordinary weather conditions, disasters, riots, acts of God, insurrection or war.

XXIV. INDEMNIFICATION. The Districts shall indemnify, defend and hold harmless the State and its officers, representatives, agents, servants, employees, successors and assigns from and against any and all (1) Claims arising, directly or indirectly, in connection with the Agreement, including the acts of commission or omission (collectively, the "Acts") of the District or District Parties; and (2) liabilities, damages, losses, costs and expenses, including but not limited to, attorneys' and other professionals' fees, arising, directly or indirectly, in connection with Claims, Acts or the Agreement. The Districts obligations under this section to indemnify, defend and hold harmless against Claims includes Claims concerning confidentiality of any part of or all of the Districts' Records, any intellectual property rights, other proprietary rights of any person or entity, copyrighted or uncopyrighted compositions, secret processes, patented or unpatented inventions, articles or appliances furnished or used in the Performance. The Districts shall not be responsible for indemnifying or holding the State harmless from any liability arising due to the negligence of the State or any other person or entity acting under the direct control or supervision of the State. The Districts shall reimburse the State for any and all damages to the real or personal property of the State caused by the Acts of the Districts or any District Parties. The State shall give the Districts reasonable notice of any such Claims. The Districts shall carry and maintain at all times during the term of the Agreement, and during the time that any provisions survive the term of the Agreement, sufficient general liability insurance to satisfy its obligations under this Agreement. The Districts shall name the State as an additional insured on the policy and shall provide a copy of the policy to the Agency prior to the effective date of the Agreement. The Districts shall not begin Performance until the delivery of the policy to the Agency. The Agency shall be entitled to recover under the insurance policy even if a body of competent jurisdiction determines that the Agency or the State is contributorily negligent. This section shall survive the Termination of the Agreement and shall not be limited by reason of any insurance coverage.

XXV. DISTRICT PARTIES. A District's members, directors, officers, shareholders, partners, managers, principal officers, representatives, agents, servants, consultants, employees or any one of them or any other person or entity with whom the District is in privity of oral or written contract and the District intends for such other person or entity to Perform under the Agreement in any capacity

XXVI. CAMPAIGN CONTRIBUTION RESTRICTION. For all State contracts as defined in P.A. 07-1 having a value in a calendar year of \$50,000 or more or a combination or series of such agreements or contracts having a value of \$100,000 or more, the authorized signatory to this Agreement expressly acknowledges receipt of the State Elections Enforcement Commission's notice advising state contractors of state campaign contribution and solicitation prohibitions, and will inform its principals of the contents of the notice. See SEEC Form 11.

Authorizing Signatures

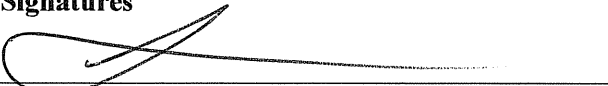
For DEEP:  8/21/13
Commissioner Date

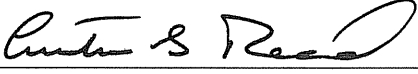
For Northwest Conservation District:  6/5/13
Signature Date

Chairman
Title

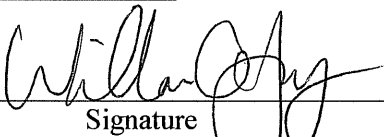
For Eastern Connecticut Conservation District:  6/12/13
Signature Date

Chair
Title

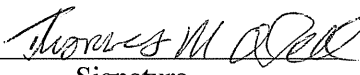
For Connecticut River Coastal Conservation District, Inc.:  5/22/13
Signature Date

Chair
Title

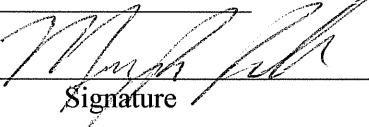
For Southwest Conservation District:  5/13/13
Signature Date

Vice-Chairperson SWCD
Title

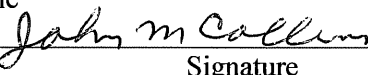
For North Central Conservation District:  5/23/13
Signature Date

Chairman
Title

EXHIBIT 1

**Connecticut Conservation District
Stormwater Pollution Control Plan Review Fee Schedule**

Single Family Residential Developments Disturbing 5 or more Acres

Number of Lots	Standard Fee	Number of Lots	Standard Fee
1	\$1,500	26	\$5,625
2	\$1,665	27	\$5,790
3	\$1,830	28	\$5,955
4	\$1,995	29	\$6,120
5	\$2,160	30	\$6,285
6	\$2,325	31	\$6,450
7	\$2,490	32	\$6,615
8	\$2,655	33	\$6,780
9	\$2,820	34	\$6,945
10	\$2,985	35	\$7,110
11	\$3,150	36	\$7,275
12	\$3,315	37	\$7,440
13	\$3,480	38	\$7,605
14	\$3,645	39	\$7,770
15	\$3,810	40	\$7,935
16	\$3,975	41	\$8,100
17	\$4,140	42	\$8,265
18	\$4,305	43	\$8,430
19	\$4,470	44	\$8,595
20	\$4,635	45	\$8,760
21	\$4,800	46	\$8,925
22	\$4,965	47	\$9,090
23	\$5,130	48	\$9,255
24	\$5,295	49	\$9,420
25	\$5,460	50	\$9,585

Over 50 lots:

\$9,585 + \$20 x number of lots over 50

SW PCP Review: Standard Fee (as shown above)

Resubmission: Standard Fee minus 50%

Post-Approval Resubmission: \$85 per hour, up to a maximum of the Standard Fee minus 50%

Express Reviews: The specified fee for an SW PCP Review, a Resubmission, or a Post-Approval Resubmission; plus 50% of the applicable fee and/or limit

Policies:

1. Payment due upon submission of SW PCP, with the exception of Post-Approval Resubmissions.
2. Payment for Post-Approval Resubmission review is due upon completion of review.
3. Written permission to enter onto and inspect the site: Due upon submission of SW PCP.

EXHIBIT 1

**Connecticut Conservation District
Stormwater Pollution Control Plan Review Fee Schedule**

Commercial and Multi Family Developments

Number of Disturbed Standard Acres Fee		Number of Disturbed Standard Acres Fee	
5	\$2,200	28	\$5,995
6	\$2,365	29	\$6,160
7	\$2,530	30	\$6,325
8	\$2,695	31	\$6,490
9	\$2,860	32	\$6,655
10	\$3,025	33	\$6,820
11	\$3,190	34	\$6,985
12	\$3,355	35	\$7,150
13	\$3,520	36	\$7,315
14	\$3,685	37	\$7,480
15	\$3,850	38	\$7,645
16	\$4,015	39	\$7,810
17	\$4,180	40	\$7,975
18	\$4,345	41	\$8,140
19	\$4,510	42	\$8,305
20	\$4,675	43	\$8,470
21	\$4,840	44	\$8,635
22	\$5,005	45	\$8,800
23	\$5,170	46	\$8,965
24	\$5,335	47	\$9,130
25	\$5,500	48	\$9,295
26	\$5,665	49	\$9,460
27	\$5,830	50	\$9,625

Over 50 acres:

\$9,625 + \$25 x number of disturbed acres over 50

SW PCP Review: Standard Fee (as shown above)

Resubmission: Standard Fee minus 50%

Post-Approval Resubmission: \$85 per hour, up to a maximum of the Standard Fee minus 50%

Express Reviews: The specified fee for an SW PCP Review, a Resubmission, or a Post-Approval Resubmission; plus 50% of the applicable fee and/or limit

Policies:

1. Payment due upon submission of SW PCP, with the exception of Post-Approval Resubmissions.
2. Payment for Post-Approval Resubmission review is due upon completion of review.
3. Written permission to enter onto and inspect the site: Due upon submission of SW PCP.

EXHIBIT 2

EXECUTIVE ORDERS

The Agreement is subject to the provisions of Executive Order No. Three of Governor Thomas J. Meskill, promulgated June 16, 1971, concerning labor employment practices, Executive Order No. Seventeen of Governor Thomas J. Meskill, promulgated February 15, 1973, concerning the listing of employment openings and Executive Order No. Sixteen of Governor John G. Rowland promulgated August 4, 1999, concerning violence in the workplace, all of which are incorporated into and are made a part of the Contract as if they had been fully set forth in it. At the Districts' request, the Client Agency shall provide a copy of these orders to the Districts. The Agreement may also be subject to Executive Order No. 7C of Governor M. Jodi Rell, promulgated July 13, 2006, concerning contracting reforms and Executive Order No. 14 of Governor M. Jodi Rell, promulgated April 17, 2006, concerning procurement of cleaning products and services, in accordance with their respective terms and conditions.

NONDISCRIMINATION

(a) For purposes of this Section, the following terms are defined as follows:

- i. "Commission" means the Commission on Human Rights and Opportunities;
- ii. "Contract" and "contract" include any extension or modification of this Agreement or contract;
- iii. "Districts" and "districts" include the Districts and any successors or assigns of the Districts or districts;
- iv. "Gender identity or expression" means a person's gender-related identity, appearance or behavior, whether or not that gender-related identity, appearance or behavior is different from that traditionally associated with the person's physiology or assigned sex at birth, which gender-related identity can be shown by providing evidence including, but not limited to, medical history, care or treatment of the gender-related identity, consistent and uniform assertion of the gender-related identity or any other evidence that the gender-related identity is sincerely held, part of a person's core identity or not being asserted for an improper purpose.
- v. "good faith" means that degree of diligence which a reasonable person would exercise in the performance of legal duties and obligations;
- vi. "good faith efforts" shall include, but not be limited to, those reasonable initial efforts necessary to comply with statutory or regulatory requirements and additional or substituted efforts when it is determined that such initial efforts will not be sufficient to comply with such requirements;
- vii. "marital status" means being single, married as recognized by the State of Connecticut, widowed, separated or divorced;
- viii. "mental disability" means one or more mental disorders, as defined in the most recent edition of the American Psychiatric Association's "Diagnostic and Statistical Manual of Mental Disorders", or a record of or regarding a person as having one or more such disorders;
- ix. "minority business enterprise" means any small contractor, District or supplier of materials fifty-one percent or more of the capital stock, if any, or assets of which is owned by a person or persons: (1) who are active in the daily affairs of the enterprise, (2) who have the power to direct the management and policies of the enterprise, and (3) who are members of a minority, as such term is defined in subsection (a) of Connecticut General Statutes § 32-9n; and
- x. "public works contract" means any agreement between any individual, firm or corporation and the State or any political subdivision of the State other than a municipality for construction, rehabilitation, conversion, extension, demolition or repair of a public building, highway or other changes or improvements in real property, or which is financed in whole or in part by the State, including, but not limited to, matching expenditures, grants, loans, insurance or guarantees.

For purposes of this Section, the terms "Contract" and "contract" do not include a contract where each District is (1) a political subdivision of the state, including, but not limited to, a municipality, (2) a quasi-public agency, as defined in Conn. Gen. Stat. Section 1-120, (3) any other state, including but not limited to any federally recognized Indian tribal governments, as defined in Conn. Gen. Stat. Section 1-267, (4) the federal government, (5) a foreign government, or (6) an agency of a subdivision, agency, state or government described in the immediately preceding enumerated items (1), (2), (3), (4) or (5).

(b) (1) The Districts agree and warrant that in the performance of the Agreement such Districts will not discriminate or permit discrimination against any person or group of persons on the grounds of race, color, religious creed, age, marital status, national origin, ancestry, sex, gender identity or expression, mental retardation, mental disability or physical disability, including, but not limited to, blindness, unless it is shown by such Districts that such disability prevents performance of the work involved, in any manner prohibited by the laws of the United States or of the State of Connecticut; and the Districts further agree to take affirmative action to insure that applicants with job-related qualifications are employed and that employees are treated when employed without regard to their race, color, religious creed, age, marital status, national origin, ancestry, sex, gender identity or expression, mental retardation, mental disability or physical disability, including, but not limited to, blindness, unless it is shown by the Districts that such disability prevents performance of the work involved; (2) the Districts agree, in all solicitations or advertisements for employees placed by or on behalf of the Districts, to state that it is

an "affirmative action-equal opportunity employer" in accordance with regulations adopted by the Commission; (3) the Districts agree to provide each labor union or representative of workers with which the Districts have a collective bargaining Agreement or other contract or understanding and each vendor with which the Districts have a contract or understanding, a notice to be provided by the Commission, advising the labor union or workers' representative of the Districts' commitments under this section and to post copies of the notice in conspicuous places available to employees and applicants for employment; (4) the Districts agree to comply with each provision of this Section and Connecticut General Statutes §§ 46a-68e and 46a-68f and with each regulation or relevant order issued by said Commission pursuant to Connecticut General Statutes §§ 46a-56, 46a-68e and 46a-68f; and (5) the Districts agree to provide the Commission on Human Rights and Opportunities with such information requested by the Commission, and permit access to pertinent books, records and accounts, concerning the employment practices and procedures of the Districts as relate to the provisions of this Section and Connecticut General Statutes § 46a-56. If the contract is a public works contract, the Districts agree and warrant that they will make good faith efforts to employ minority business enterprises as Districts and suppliers of materials on such public works projects.

(c) Determination of the Districts' good faith efforts shall include, but shall not be limited to, the following factors: The Districts' employment and subcontracting policies, patterns and practices; affirmative advertising, recruitment and training; technical assistance activities and such other reasonable activities or efforts as the Commission may prescribe that are designed to ensure the participation of minority business enterprises in public works projects.

(d) The Districts shall develop and maintain adequate documentation, in a manner prescribed by the Commission, of its good faith efforts.

(e) The Districts shall include the provisions of subsection (b) of this Section in every subcontract or purchase order entered into in order to fulfill any obligation of a contract with the State and such provisions shall be binding on the Districts, vendor or manufacturer unless exempted by regulations or orders of the Commission. The Districts shall take such action with respect to any such subcontract or purchase order as the Commission may direct as a means of enforcing such provisions including sanctions for noncompliance in accordance with Connecticut General Statutes §46a-56; provided if such Districts become involved in, or is threatened with, litigation with the Districts or vendor as a result of such direction by the Commission, the Districts may request the State of Connecticut to enter into any such litigation or negotiation prior thereto to protect the interests of the State and the State may so enter.

(f) The Districts agree to comply with the regulations referred to in this Section as they exist on the date of this Agreement and as they may be adopted or amended from time to time during the term of this Agreement and any amendments thereto.

(g) (1) The Districts agree and warrant that in the performance of the Agreement such Districts will not discriminate or permit discrimination against any person or group of persons on the grounds of sexual orientation, in any manner prohibited by the laws of the United States or the State of Connecticut, and that employees are treated when employed without regard to their sexual orientation; (2) the Districts agree to provide each labor union or representative of workers with which such Districts have a collective bargaining Agreement or other contract or understanding and each vendor with which such Districts have a contract or understanding, a notice to be provided by the Commission on Human Rights and Opportunities advising the labor union or workers' representative of the Districts' commitments under this section, and to post copies of the notice in conspicuous places available to employees and applicants for employment; (3) the Districts agree to comply with each provision of this section and with each regulation or relevant order issued by said Commission pursuant to Connecticut General Statutes § 46a-56; and (4) the Districts agree to provide the Commission on Human Rights and Opportunities with such information requested by the Commission, and permit access to pertinent books, records and accounts, concerning the employment practices and procedures of the Districts which relate to the provisions of this Section and Connecticut General Statutes § 46a-56.

(h) The Districts shall include the provisions of the foregoing paragraph in every subcontract or purchase order entered into in order to fulfill any obligation of a contract with the State and such provisions shall be binding on the Districts, vendor or manufacturer unless exempted by regulations or orders of the Commission. The Districts shall take such action with respect to any such subcontract or purchase order as the Commission may direct as a means of enforcing such provisions including sanctions for noncompliance in accordance with Connecticut General Statutes § 46a-56; provided, if such Districts become involved in, or is threatened with, litigation with the Districts or vendor as a result of such direction by the Commission, the Districts may request the State of Connecticut to enter into any such litigation or negotiation prior thereto to the Connecticut Department of Energy and Environmental Protection (DEEP)."

Note: Place on official Letterhead. Need to document registered name with CT Secretary of State C.O.N.C.O.R.D.

CERTIFICATION

I, **XXXXXXXXXXXXXXXXXX**, Chair of the **XXXXXXXXXXXXXXXXXX** an entity lawfully organized and existing under the laws of Connecticut, do hereby certify that the following is a true and correct copy of a resolution adopted on the **>>>>**day of **>>>>**, 2011, by the governing body of the **XXXXXX** in accordance with all of its documents of governance and management and the laws of Connecticut and further certify that such resolution has not been modified, rescinded or revoked, and is a present in full force and effect.

RESOLVED: That the **XXXXXXXXXXXXXXXXXX** hereby adopts as its policy to support the nondiscrimination agreements and warranties required under Conn. Gen. Stat. § 4a-60(a)(1) and § 4a-60a(a)(1), as amended in State of Connecticut Public Act 07-245 and sections 9(a)(1) and 10(a)(1) of Public Act 07-142, as those statutes may be amended from time to time.

IN WITNESS WHEREOF, the undersigned has executed this certificate **this >>>>day of **>>>>**, 2013.**

Signature

Date

CONSERVATION DISTRICT PLAN REVIEW CERTIFICATION

Registrations submitted to DEEP for which a Conservation District has performed the Plan review pursuant to Section 3(b)(10) of the General Permit for the Discharge of Stormwater and Dewatering Wastewaters from Construction Activities shall include the following certification:

"I hereby certify that I am an employee of the [INSERT NAME OF DISTRICT] Conservation District and that I meet the qualifications to review Stormwater Pollution Control Plans as specified in the Memorandum of Agreement between the Connecticut Department of Energy & Environmental Protection and the Connecticut Conservation Districts. I am making this certification in connection with a registration under the General Permit for the Discharge of Stormwater and Dewatering Wastewaters from Construction Activities, submitted to the commissioner by [INSERT NAME OF REGISTRANT] for an activity located at [INSERT ADDRESS OF PROJECT OR ACTIVITY]. I have personally examined and am familiar with the information that provides the basis for this certification, including but not limited to all information described in such general permit, and I certify, based on reasonable investigation, including my inquiry of those individuals responsible for obtaining such information, that the information upon which this certification is based is true, accurate and complete to the best of my knowledge and belief. I certify, based on my review of the requirements of such general permit and on the standard of care for such projects, that the Plan is in compliance with the requirements of the general permit. I understand that knowingly making any false statement in this certification may be punishable as a criminal offense, including the possibility of fine and imprisonment, under section 53a-157b of the Connecticut General Statutes and any other applicable law."

Registrations submitted to DEEP for which the District review was begun but ***could not be completed*** within the time limits specified in the Memorandum of Agreement shall include the following statement:

"I hereby certify that I am an employee of the [INSERT NAME OF DISTRICT] Conservation District and that I meet the qualifications to review Stormwater Pollution Control Plans as specified in the Memorandum of Agreement between the Connecticut Department of Energy & Environmental Protection and the Connecticut Conservation Districts. I am making this statement in connection with a registration under the General Permit for the Discharge of Stormwater and Dewatering Wastewaters from Construction Activities, submitted to the commissioner by [INSERT NAME OF REGISTRANT] for an activity located at [INSERT ADDRESS OF PROJECT OR ACTIVITY]. I hereby state that the review of the Stormwater Pollution Control Plan (Plan) for such registration was not completed within the time frames specified in the Memorandum of Agreement. Consequently, I cannot certify that the Plan is in compliance with the requirements of the general permit."



General Permit for the Discharge of Stormwater and Dewatering Wastewaters Associated with Construction Activities

APPENDIX G

Historic Preservation Review

Pursuant to Chapter 184a, Section 10-387 of the Connecticut General Statutes, the Department of Energy & Environmental Protection (DEEP) shall review, in consultation with the Connecticut Commission on Culture and Tourism, its policies and practices for consistency with the preservation and study of CT's archaeological and historical sites. Pursuant to this requirement, DEEP has outlined the following process for assessing the potential for and the presence of historic and/or archaeological resources at a proposed development site. DEEP advises a review for the resources identified below *be initiated up to one year* prior to registration for this permit (*or prior to property purchase if possible*) and in conjunction with the local project approval process. However, a review conducted for an Army Corps of Engineers Section 404 wetland permit would meet this requirement.

Step 1: Determine if the proposed site is within an area of significance by consulting the following resources:

1. CT Register of Historic Places found at the link below:
<http://www.nationalregisterofhistoricplaces.com/CT/state.html#pickem>
2. The municipality of the proposed development site for its designations of local historic districts, including but not limited to, local Historic District and/or Property Statutes.

Step 2: Assess site characteristics to determine the presence of a potential archaeological site, sacred site, and/ or sacred object as described below:

Definitions:

1. "Archaeological site" means a location where there exists material evidence that is not less than fifty years old of the past life and culture of human beings in the state.
2. "Sacred site" or "sacred land" means any space, including an archaeological site, of ritual or traditional significance in the culture and religion of Native Americans that is listed or eligible for listing on the National Register of Historic Places (16 USC 470a, as amended) or the state register of historic places defined in section 10-410, including, but not limited to, marked and unmarked human burials, burial areas and cemeteries, monumental geological or natural features with sacred meaning or a meaning central to a group's oral traditions; sites of ceremonial structures, including sweat lodges; rock art sites, and sites of great historical significance to a tribe native to this state.
3. "Sacred object" means any archaeological artifact or other object associated with a sacred site.

Site Prescreening Criteria:

1. Does the proposed development site include lands within 300 feet of surface water features, such as streams, brooks, lakes, or marshes?
If "yes", proceed to Criterion 2. If the answer to Criterion 1 is "no", then there is a low potential for prehistoric period archaeological resources - Proceed to Criterion 3.

2. Does the area of anticipated construction or ground disturbance include soils classified by the Natural Resource Conservation Service as "Sandy Loam/ Loamy sand" or "Sandy Gravel Loam" not including "Fine Sandy Loam/ Loamy sand" with slopes less than or equal to 15%? (Soil mapping information is available for free from:
<http://websoilsurvey.nrcs.usda.gov/app/WebSoilSurvey.aspx>)

If the answer to Criterion 2 is no, then there is a low potential for prehistoric period archaeological resources - Proceed to Criterion 3. If yes, the project site may contain significant prehistoric period archaeological resources

– assess all other criteria and proceed to Step 3.

3. Are there buildings or structures over 150 years in age with the project site?

If no, proceed to Criterion 4. If yes, the project site may contain significant historic period archaeological resources – assess all other criteria and proceed to Step 3.

4. Are there buildings or structures shown within or immediately adjacent to the project site on the 1850's Connecticut County maps?

Historic County maps are here:

Fairfield - <http://www.flickr.com/photos/uconnlibrariesmagic/3387034755/>

Hartford - <http://www.flickr.com/photos/uconnlibrariesmagic/3386955421/>

Litchfield - <http://www.flickr.com/photos/uconnlibrariesmagic/3387765290/>

Middlesex - <http://www.flickr.com/photos/uconnlibrariesmagic/3386956185/>

New Haven - <http://www.flickr.com/photos/uconnlibrariesmagic/3386956345/>

New London - <http://www.flickr.com/photos/uconnlibrariesmagic/3387766080/>

Tolland - <http://www.flickr.com/photos/uconnlibrariesmagic/3386957013/>

Windham - <http://www.flickr.com/photos/uconnlibrariesmagic/3387766950/>

To look for buildings and structures click on the appropriate county map link. From the “Actions” drop-down menu choose “View all sizes”. On the “Photo/All sizes” page, choose “Original” to view the county map at an enlarged scale.

If no, there is a low potential for significant historic period archaeological resources. If yes, the site may contain significant historic period archaeological resources- assess all other criteria and proceed to Step 3.

Step 3: If you answered yes to Criterion 2, 3, or 4, please contact Daniel Forrest (860-256-2761 or daniel.forrest@ct.gov) or the current environmental review coordinator at the State Historic Preservation Office, Department of Economic and Community Development for additional guidance.

Step 4: Report in the Registration Form for the General Permit for the Discharge of Stormwater and Dewatering Wastewaters Associated with Construction Activities that a review has been conducted and the results of the review (i.e. the proposed site does not have the potential for historic/ archaeological resources, or that such potential exists and is being or has been reviewed by the Connecticut Commission on Culture and Tourism).

Please note that DEEP will refer all proposed sites with a historic/ archaeological resource potential (as identified in Steps 1 & 2 above) to the State Historic Preservation Office at the Department of Economic and Community Development..

Appendix H

Wild & Scenic Rivers Guidance

Overview: Wild and Scenic Rivers Act

The Wild and Scenic Rivers Act (WSRA) charges administration of rivers in the National Wild and Scenic Rivers System (National System) to four federal land management agencies (Bureau of Land Management, National Park Service, U.S. Fish and Wildlife Service, and U.S. Forest Service). However, to protect and enhance river values as directed in the WSRA, it is essential to use the authorities of a number of other federal agencies in administering the water column, river bed/bank, and upland river corridor.

Congress declared a policy to protect selected rivers in the nation through the WSRA. The river-administering agencies are to protect the river’s identified values, free-flowing condition, and associated water quality. Specifically, each component is to be “administered in such manner as to protect and enhance the (outstandingly remarkable) values (**ORVs**) which caused it to be included in said system. . . .”

The WSRA also directs other federal agencies to protect river values. It explicitly recognizes the Federal Energy Regulatory Commission, Environmental Protection Agency, Army Corps of Engineers and any other federal department or agency with lands on or adjacent to designated (or congressionally authorized study) rivers or that permit or assist in the construction of water resources projects.

Pertinent Sections of the Wild and Scenic Rivers Act

The full Wild and Scenic Rivers Act can be found at the website: www.rivers.gov

Pertinent Sections related to the mandate to protect river values through coordinated federal actions is found in several sections of the WSRA:

Section 1(b)	Section 7(a)	Section 10(a)
Section 12(a)	Section 12(c)	

Designated Rivers under the Wild and Scenic Rivers Act and Contact Information

The full listing of designated rivers can be found on the website www.rivers.gov

As of the date of this publication, there are two designated rivers in Connecticut, both of which are managed under the Partnership Wild and Scenic Rivers Program, through a Coordinating Committee consisting of representatives from local communities and organizations, state government and the National Park Service. More information about these rivers, their watersheds, approved management plans, the Wild and Scenic Coordinating Committees and specific contact information can be found on the websites.

1. West Branch of the Farmington River: www.farmingtonriver.org
2. Eightmile River: www.eightmileriver.org



Connecticut Department of
Energy & Environmental Protection
 Bureau of Materials Management & Compliance Assurance
 Water Permitting & Enforcement Division

General Permit Registration Form for the Discharge of Stormwater and Dewatering Wastewaters from Construction Activities, effective 10/1/13 (non-electronic form)

Prior to completing this form, you **must** read the instructions for the subject general permit available at [DEEP-WPED-INST-015](#).

This form must be filled out electronically before being printed.

You must submit the registration fee along with this form.

The [status of your registration](#) can be checked on the DEEP's ezFile Portal. Please note that DEEP will no longer mail certificates of registration.

CPPU USE ONLY	
App #:	_____
Doc #:	_____
Check #:	_____
Program: Stormwater	

Part I: Registration Type

Select the appropriate boxes identifying the registration type and registration deadline.

Registration Type		Registration Timeline		
<input type="checkbox"/>	Re-registration Existing Permit No. GSN _____	On or before February 1, 2014* *Note: Failure to renew a permit by this date will require submission of new registration. Re-registrants must only complete Parts I, II, III (except Question 8), IV - Question 1, VII and submit Attachment A.		
<input type="checkbox"/>	New Registration (Refer to Section 2 of the permit for definitions of Locally Exempt and Locally Approvable Projects)	<input type="checkbox"/> Locally Approvable Projects Size of soil disturbance:	New registration - Sixty (60) days prior to the initiation of the construction activity for: Sites with a total soil disturbance area of 5 or more acres	
		<input type="checkbox"/> Locally Exempt Projects Size of soil disturbance:	<input type="checkbox"/>	New registration - Sixty (60) days prior to the initiation of the construction activity for: Sites with a total disturbance area of one (1) to twenty (20) acres except those with discharges to impaired waters or tidal wetlands
			<input type="checkbox"/>	New registration - Ninety (90) days prior to the initiation of the construction activity for: (i) Sites with a total soil disturbance area greater than twenty (20) acres, or (ii) Sites discharging to a tidal wetland (that is not fresh-tidal and is located within 500 feet), or (iii) Sites discharging to an impaired water listed in the "Impaired Waters Table for Construction Stormwater Discharges"

Part II: Fee Information

1. New Registrations
 - a. Locally approvable projects (registration only):
 - \$625 [#1855]
 - b. Locally exempt projects (registration and Plan):
 - \$3,000 total soil disturbance area \geq one (1) and < twenty (20) acres. [#1856]
 - \$4,000 total soil disturbance \geq twenty (20) acres and < fifty (50) acres. [#1857]
 - \$5,000 total soil disturbance \geq fifty (50) acres. [#1858]
2. Re-Registrations
 - \$625 (sites previously registered prior to September 1, 2012) [#1853]
 - \$0 (sites previously registered between September 1, 2012 and the issuance date of this permit) [#1854]

The fees for municipalities shall be half of those indicated in subsections 1.a., 1.b., and 2 above pursuant to section 22a-6(b) of the Connecticut General Statutes. State and Federal agencies shall pay the full fees specified in this subsection. The registration will not be processed without the fee. The fee shall be non-refundable and shall be paid by certified check or money order payable to the Department of Energy and Environmental Protection.

Part III: Registrant Information

- If a registrant is a corporation, limited liability company, limited partnership, limited liability partnership, or a statutory trust, it must be registered with the Secretary of the State. If applicable, the registrant's name shall be stated **exactly** as it is registered with the Secretary of the State. This information can be accessed at [CONCORD](#).
- If a registrant is an individual, provide the legal name (include suffix) in the following format: First Name; Middle Initial; Last Name; Suffix (Jr, Sr., II, III, etc.).

1. Registrant /Client Name:

Registrant Type ▾

Secretary of the State business ID #: ██████████

Mailing Address:

City/Town: State: Zip Code:

Business Phone: ext.:

Example:(xxx) xxx-xxxx

Contact Person: Title:

E-Mail:

Additional Phone Number (if applicable): ext.

2. List billing contact, if different than the registrant:

Name:

Mailing Address:

City/Town: State: Zip Code:

Business Phone: ext.:

Contact Person: Title:

Part III: Registrant Information (continued)

3. List primary contact for departmental correspondence and inquiries, if different than the registrant:

Name:

Mailing Address:

City/Town:

State:

Zip Code:

Business Phone:

ext.:

Site Phone:

Emergency Phone:

Contact Person:

Title:

Association (e.g. developer, general or site contractor, etc.):

4. List owner of the property on which the activity will take place, if different from registrant:

Name:

Mailing Address:

City/Town:

State:

Zip Code:

Business Phone:

ext.:

Contact Person:

5. List developer, if different from registrant or primary contact:

Name:

Mailing Address:

City/Town:

State:

Zip Code:

Business Phone:

ext.:

Contact Person:

Title:

6. List general contractor, if different from registrant or primary contact:

Name:

Mailing Address:

City/Town:

State:

Zip Code:

Business Phone:

ext.:

Site Phone:

Off Hours Phone:

Contact Person:

Title:

7. List any engineer(s) or other consultant(s) employed or retained to assist in preparing the registration and/or Stormwater Pollution Control Plan. Please select if additional sheets are necessary, and label and attach them to this sheet.

Name:

Mailing Address:

City/Town:

State:

Zip Code:

Business Phone:

ext.:

Contact Person:

Title:

Service Provided:

8. List Reviewing Qualified Professional (for locally approvable projects only):

Name:

Contact Person:

Mailing Address:

City/Town:

State:

Zip Code:

Business Phone:

ext.:

Part IV: Site Information

1. Site Name:

Street Address or Description of Location:

City/Town:

State: CT

Zip Code:

Brief Description of construction activity:

Project Start Date:

/

Anticipated Completion Date:

/

(month/yr)

(month/yr)

Normal working hours: to

2. MINING: Is the activity on the site in question part of mining operations (i.e. sand and gravel)? Yes No

If yes, mining is not authorized by this general permit. You must submit the Registration Form for the General Permit for the Discharge of Stormwater Associated with Industrial Activity.

3. COMBINED OR SANITARY SEWER: Does all of the stormwater from the proposed activity discharge to a combined or sanitary sewer (i.e. a sewage treatment plant)? Yes No

If yes, this activity is not regulated by this permit. Contact the Water Permitting & Enforcement Division at 860-424-3018.

4. INDIAN LANDS: Is or will the facility be located on federally recognized Indian lands Yes No

5. COASTAL BOUNDARY: Is the activity which is the subject of this registration located within the coastal boundary as delineated on DEEP approved coastal boundary maps Yes No

The coastal boundaries fall within the following towns: Branford, Bridgeport, Chester, Clinton, Darien, Deep River, East Haven, East Lyme, Essex, Fairfield, Greenwich, Groton (City and Town), Old Lyme, Guilford, Hamden, Ledyard, Lyme, Madison, Milford, Montville, New London, New Haven, North Haven, Norwalk, Norwich, Old Saybrook, Orange, Preston, Shelton, Stamford, Stonington (Borough and Town), Stratford, Waterford, West Haven, Westbrook and Westport.

If "yes", and this registration is for a new authorization or a modification of an existing authorization where the physical footprint of the subject activity is modified, you must provide documentation the DEEP Office of Long Island Sound Programs or the local governing authority has issued a coastal site plan approval or determined the project is exempt from coastal site plan review. Provide this documentation with your registration as Attachment B. See guidance in Appendix D of the general permit. Information on the coastal boundary is available at the local town hall or at www.cteco.uconn.edu/map_catalog.asp. Additional DEEP Maps and Publications are available by contacting DEEP staff at 860-424-3555.

Part IV: Site Information (continued)

6. ENDANGERED OR THREATENED SPECIES:

In order to be eligible to register for this General Permit, each registrant must perform a self-assessment, obtain a limited one-year determination, or obtain a safe-harbor determination regarding threatened and endangered species. This may include the need to develop and implement a mitigation plan. While each alternative has different limitations, the alternatives are not mutually exclusive; a registrant may register for this General Permit using more than one alternative. See Appendix A of the General Permit. Each registrant must complete this section AND Attachment C to this Registration form and a registrant who does not or cannot do so is not eligible to register under this General Permit.

Each registrant must perform a review of the Department's Natural Diversity Database maps to determine if the site of the construction activity is located within or in proximity (within ¼ mile) to a shaded area.

- a. Provide the date the NDDDB maps were reviewed: _____ (Print a copy of the NDDDB map you viewed since it must be submitted with this registration as part of Attachment C.)
- b. For a registrant using a limited one-year determination or safe harbor determination to register for this General Permit, provide the Department's Wildlife Division NDDDB identification number for any such determination: _____ (The number is on the determination issued by the Department's Wildlife Division).
- c. verify that I have completed Attachment C to this Registration Form. Yes

For more information on threatened and endangered species requirements, refer to Appendix A and Section 3(b)(2) of this General Permit, visit the DEEP website at www.ct.gov/deep/nddbrequest or call the NDDDB at 860-424-3011.

7. WILD AND SCENIC RIVERS: Is the proposed project within the watershed of a designated Wild and Scenic River? (See Appendix H for guidance) Yes No
8. AQUIFER PROTECTION AREAS: Is the site located within a mapped aquifer protection area www.ct.gov/deep/aquiferprotection as defined in section 22a-354h of the CT General Statutes? (For additional guidance, please refer to Appendix C of the General Permit) Yes No
9. CT GUIDELINES FOR SOIL EROSION AND SEDIMENT CONTROL: Is the activity in accordance with CT Guidelines for Erosion and Sediment Control and local erosion & sediment control ordinances, where applicable? Yes No
10. HISTORIC AND/OR ARCHAEOLOGICAL RESOURCES:
Has the site of the proposed activity been reviewed (using the process outlined in Appendix G of this permit) for historic and/or archaeological resources? Yes No
 - a. The review indicates the proposed site does not have the potential for historic/ archaeological resources, OR Yes No
 - b. The review indicated historic and/ or archaeological resource potential exists and the proposed activity is being or has been reviewed by the Offices of Culture and Tourism, OR Yes No
 - c. The proposed activity has been reviewed and authorized under an Army Corps of Engineers Section 404 wetland permit. Yes No
11. CONSERVATION OR PRESERVATION RESTRICTION:
Is the property subject to a conservation or preservation restriction? Yes No

If Yes, proof of written notice of this registration to the holder of such restriction or a letter from the holder of such restriction verifying that this registration is in compliance with the terms of the restriction, must be submitted as Attachment D.

Part V: Stormwater Discharge Information

Table 1						
Outfall #	a) Type	b) Pipe Material	c) Pipe Size	d) Note: To find lat/long, go to: CT ECO . A decimal format is required here. Directions on how to use CT ECO to find lat./long. and conversions can be found in Part V, Section d of the DEEP-WPED-INST-015 .		e) What method was used to obtain your latitude/longitude information?
				Longitude	Latitude	
<input type="text"/>	Select One: <input type="text"/>	Select One: <input type="text"/>	Select One: <input type="text"/>	- <input type="text"/>	<input type="text"/>	Select One: <input type="text"/>
<input type="text"/>	Select One: <input type="text"/>	Select One: <input type="text"/>	Select One: <input type="text"/>	- <input type="text"/>	<input type="text"/>	Select One: <input type="text"/>
<input type="text"/>	Select One: <input type="text"/>	Select One: <input type="text"/>	Select One: <input type="text"/>	- <input type="text"/>	<input type="text"/>	Select One: <input type="text"/>
<input type="text"/>	Select One: <input type="text"/>	Select One: <input type="text"/>	Select One: <input type="text"/>	- <input type="text"/>	<input type="text"/>	Select One: <input type="text"/>
<input type="text"/>	Select One: <input type="text"/>	Select One: <input type="text"/>	Select One: <input type="text"/>	- <input type="text"/>	<input type="text"/>	Select One: <input type="text"/>

Table 2						
Outfall #	a) For temporary and permanent outfalls, provide a start date. For temporary discharges, also provide a date the discharge will cease.	b) For the drainage area associated with each outfall: Effective Impervious Area Before Construction	c) For the drainage area associated with each outfall: Effective Impervious Area After Construction	d) To what system or receiving water does your stormwater runoff discharge? either "storm sewer" or "wetlands/waterbody" (If you select "storm sewer" proceed to Part VI of the form. If you select "wetlands/waterbody" proceed to next question)	e) For each outfall, does it discharge to any of the following towns: <i>Branford, Kent, Manchester, Meriden, North Branford, Norwalk, or Wilton?</i> (If no, proceed to Part VI of the form. If yes, proceed to next question.)	f) For each outfall, does it discharge to a "freshwater" or "salt water" ? (If you select "freshwater" proceed to Table 3. If you selected "salt water", proceed to Part VI of the form.)
<input type="text"/>	- mm/dd-mm/dd	sq feet	sq feet	Select one:	<input type="checkbox"/> Yes <input type="checkbox"/> No	Select one:
<input type="text"/>	- mm/dd-mm/dd	sq feet	sq feet	Select one:	<input type="checkbox"/> Yes <input type="checkbox"/> No	Select one:
<input type="text"/>	- mm/dd-mm/dd	sq feet	sq feet	Select one:	<input type="checkbox"/> Yes <input type="checkbox"/> No	Select one:
<input type="text"/>	- mm/dd-mm/dd	sq feet	sq feet	Select one:	<input type="checkbox"/> Yes <input type="checkbox"/> No	Select one:
<input type="text"/>	- mm/dd-mm/dd	sq feet	sq feet	Select one:	<input type="checkbox"/> Yes <input type="checkbox"/> No	Select one:
		total sq feet	total sq feet			

Part V: Stormwater Discharge Information (continued)

Table 3 Provide the following information about the receiving water(s)/wetland(s) that receive stormwater runoff from your site:			
Outfall #	a) What is your 305b ID # (water body ID #)? (Section 3.b, of the DEEP-WPED-INST-015 , explains how to find this information)	b) Is your receiving water identified as a impaired water in the " Impaired Waters Table for Construction Stormwater Discharges "? If yes, proceed to next question. If no, proceed to Part VI: Pollution Control Plan.	c) Has any Total Maximum Daily Load (TMDL) been approved for the impaired water?
█	█	<input type="checkbox"/> Y <input type="checkbox"/> N	<input type="checkbox"/> Y <input type="checkbox"/> N
█	█	<input type="checkbox"/> Y <input type="checkbox"/> N	<input type="checkbox"/> Y <input type="checkbox"/> N
█	█	<input type="checkbox"/> Y <input type="checkbox"/> N	<input type="checkbox"/> Y <input type="checkbox"/> N
█	█	<input type="checkbox"/> Y <input type="checkbox"/> N	<input type="checkbox"/> Y <input type="checkbox"/> N
█	█	<input type="checkbox"/> Y <input type="checkbox"/> N	<input type="checkbox"/> Y <input type="checkbox"/> N

Part V: Stormwater Discharge Information (continued)

Impaired waters: If you answered “yes” to Table 3, question b., **verify** that the project’s Pollution Control Plan (Plan) addresses the control measures below in Question 1 or 2, as appropriate.

1. If the impaired water does not have a TMDL, confirm compliance by selecting 1.a. or 1.b. below:

a. No more than 3 acres is disturbed at any time; Yes

OR

b. Stormwater runoff from a 2 yr, 24 rain event is **retained**. Yes

2. If the impaired water has a TMDL, confirm compliance by selecting 2.a. and 2.b. below and either question 2.c.1. or 2.c.2. below:

a. The Plan documents there is sufficient remaining Waste Load Allocations (WLA) in the TMDL for the proposed discharge, Yes

AND

b. Control measures shall be implemented to assure the WLA will not be exceeded, Yes

AND

c. 1. Stormwater discharges will be monitored for the indicator pollutant identified in the TMDL, Yes

OR

2. The Plan documents specific requirements for stormwater discharges specified in the TMDL. Yes

Part VI: Pollution Control Plan (select one of the following four categories)

- I am registering a Locally Exempt project and submitting the required electronic Plan (in Adobe™ PDF or similar publically available format) pursuant to Section 3(c)(2)(E) of this permit.
- Plan is attached to this registration form
- Plan is available at the following Internet Address (URL):
- I am registering a Locally Approvable project and have chosen not to submit the Plan with this registration pursuant to Section 3(c)(1) of this permit.
- I am registering a Locally Approvable project and have chosen to make my Plan electronically available pursuant to Section 4(c)(2)(N) of this permit.
- Plan is attached to this registration form
- Plan is available at the following Internet Address (URL):
- I am registering a Locally Exempt project and do not have the capability to submit the Plan electronically. Therefore, I am submitting a paper copy with this registration as Attachment E.

Part VII: Registrant Certification

The registrant *and* the individual(s) responsible for actually preparing the registration must sign this part. A registration will be considered incomplete unless all required signatures are provided.

For New Registrants:

" I hereby certify that I am making this certification in connection with a registration under such general permit,
 [INSERT NAME OF REGISTRANT BELOW]

submitted to the commissioner by [] for

[INSERT ADDRESS OF PROJECT OR ACTIVITY BELOW]

an activity located at [] and that all terms and conditions of the general permit are being met for all discharges which have been initiated and such activity is eligible for authorization under such permit. I further certify that a system is in place to ensure that all terms and conditions of this general permit will continue to be met for all discharges authorized by this general permit at the site. I certify that the registration filed pursuant to this general permit is on complete and accurate forms as prescribed by the commissioner without alteration of their text. I certify that I have personally examined and am familiar with the information that provides the basis for this certification, including but not limited to all information described in Section 3(b)(8)(A) of such general permit, and I certify, based on reasonable investigation, including my inquiry of those individuals responsible for obtaining such information, that the information upon which this certification is based is true, accurate and complete to the best of my knowledge and belief. I certify that I have made an affirmative determination in accordance with Section 3(b)(8)(B) of this general permit. I understand that the registration filed in connection with such general permit is submitted in accordance with and shall comply with the requirements of Section 22a-430b of Connecticut General Statutes. I also understand that knowingly making any false statement made in the submitted information and in this certification may be punishable as a criminal offense, including the possibility of fine and imprisonment, under Section 53a-157b of the Connecticut General Statutes and any other applicable law."

For Re-registrants:

" I hereby certify that I am making this certification in connection with a registration under the General Permit for the Discharge of Stormwater and Dewatering Wastewaters from Construction Activities, submitted to the commissioner
 [INSERT NAME OF REGISTRANT BELOW]

by [] for an activity located at

[INSERT ADDRESS OF PROJECT OR ACTIVITY BELOW]

[] and that all terms and conditions of the general permit are being met for all discharges which have been initiated and such activity is eligible for authorization under such permit. I further certify that all designs and plans for such activity meet the current terms and conditions of the general permit in accordance with Section 5(b)(5)(C) of such general permit and that a system is in place to ensure that all terms and conditions of this general permit will continue to be met for all discharges authorized by this general permit at the site. I certify that the registration filed pursuant to this general permit is on complete and accurate forms as prescribed by the commissioner without alteration of their text. I certify that I have personally examined and am familiar with the information that provides the basis for this certification, including but not limited to all information described in Section 3(b)(8)(A) of such general permit, and I certify, based on reasonable investigation, including my inquiry of those individuals responsible for obtaining such information, that the information upon which this certification is based is true, accurate and complete to the best of my knowledge and belief. I also understand that knowingly making any false statement made in the submitted information and in this certification may be punishable as a criminal offense, including the possibility of fine and imprisonment, under Section 53a-157b of the Connecticut General Statutes and any other applicable law."

Signature of Registrant	Date
Name of Registrant (print or type)	Title (if applicable)
Signature of Preparer (if different than above)	Date
Name of Preparer (print or type)	Title (if applicable)

**Part VIII: Professional Engineer (or Landscape Architect, where appropriate) Design Certification
(for publically approvable and exempt projects)**

The following certification must be signed by a Professional Engineer or Landscape Architect where appropriate.

<p>"I hereby certify that I am a <input type="text"/> choose qualification licensed in the State of Connecticut. I am making this certification in connection with a registration under such general permit, submitted to the commissioner by <input type="text"/> [INSERT NAME OF REGISTRANT BELOW]</p> <p><input type="text"/> for an activity located at <input type="text"/> [INSERT ADDRESS OF PROJECT OR ACTIVITY BELOW]</p> <p><input type="text"/></p> <p>I certify that I have thoroughly and completely reviewed the Stormwater Pollution Control Plan for the project or activity covered by this certification. I further certify, based on such review and on the standard of care for such projects, that the Stormwater Pollution Control Plan has been prepared in accordance with the Connecticut Guidelines for Soil Erosion and Sediment Control, as amended, the Stormwater Quality Manual, as amended, and the conditions of the general permit, and that the controls required for such Plan are appropriate for the site. I further certify, based on reasonable investigation, including my inquiry of those individuals responsible for obtaining such information, that the information upon which this certification is based is true, accurate, and complete to the best of my knowledge and belief. I also understand that knowingly making any false statement in this certification may subject me to sanction by the Department and/or be punishable as a criminal offense, including the possibility of fine and imprisonment, under section 53a-157b of the Connecticut General Statutes and any other applicable law."</p>	
Signature of Design Professional	Date
<input type="text"/>	<input type="text"/>
Name of Professional (print or type)	Title
<input type="text"/>	<input type="text"/>
Mailing Address	City/Town
<input type="text"/>	<input type="text"/>
State	Zip Code
<input type="text"/>	<input type="text"/>
	Business Phone
	<input type="text"/>
	License #
	<input type="text"/>
Affix P.E./L.A Stamp Here	

Part IX: Reviewing Qualified Professional Certification

The following certification must be signed by a) a Conservation District reviewer OR, b) a qualified soil erosion and sediment control and/or professional engineer

Review certification by Conservation District:

1.) District: list of districts

Date of Affirmative Determination:

“ I am making this certification in connection with a registration under General Permit for the Discharge of Stormwater and Dewatering Wastewaters from Construction Activities, submitted to the commissioner

[INSERT NAME OF REGISTRANT BELOW]

by _____ for an activity located at
[INSERT ADDRESS OF PROJECT OR ACTIVITY BELOW]

I have personally examined and am familiar with the information that provides the basis for this certification, and I affirm, based on the review described in Section 3(b)(11)(C) of this general permit and on the standard of care for such projects, that the Stormwater Pollution Control Plan is adequate to assure that the activity authorized under this general permit will comply with the terms and conditions of such general permit and that all stormwater management systems: (i) have been designed to control pollution to the maximum extent achievable using measures that are technologically available and economically practicable and that conform to those in the Guidelines and the Stormwater Quality Manual; (ii) will function properly as designed; (iii) are adequate to ensure compliance with the terms and conditions of this general permit; and (iv) will protect the waters of the state from pollution.”

Signature of District Professional and Date

Name of District Professional and License Number (if applicable)

Or

Review certification by Qualified Professional

Company: _____

Name: _____

License # : _____

Level of independency of professional:

Required for all projects disturbing over 1 acre:

1. I verify I am not an employee of the registrant. Yes
2. I verify I have no ownership interest of any kind in the project for which the registration is being submitted. Yes

Required for projects with 15 or more acres of site disturbance (in addition to questions 1&2):

3. I verify I did not engage in any activities associated with the preparation, planning, designing or engineering of the soil erosion and sediment control plan or stormwater management systems plan for this registrant. Yes
4. I verify I am not under the same employ as any person associated with the preparation, planning, designing or engineering of the soil erosion and sediment control plan or stormwater management systems plan for this registrant. Yes

Part IX: Reviewing Qualified Professional Certification (continued)

"I hereby certify that I am a qualified professional engineer or qualified soil erosion and sediment control professional, or both, as defined in the General Permit for Discharge of Stormwater and Dewatering Wastewaters from Construction Activities and as further specified in Sections 3(b)(11)(A) and (B) of such general permit. I am making this certification in connection with a registration under such general permit,

[INSERT NAME OF REGISTRANT BELOW]

submitted to the commissioner by

[INSERT ADDRESS OF PROJECT OR ACTIVITY BELOW]

for an activity located at

I have personally examined and am familiar with the information that provides the basis for this certification, including but not limited to all information described in Section 3(b)(11)(C) of such general permit, and I certify, based on reasonable investigation, including my inquiry of those individuals responsible for obtaining such information, that the information upon which this certification is based is true, accurate and complete to the best of my knowledge and belief. I further certify that I have made the affirmative determination in accordance with Sections 3(b)(11)(D)(i) and (ii) of this general permit. I understand that this certification is part of a registration submitted in accordance with Section 22a-430b of Connecticut General Statutes and is subject to the requirements and responsibilities for a qualified professional in such statute. I also understand that knowingly making any false statement in this certification may be punishable as a criminal offense, including the possibility of fine and imprisonment, under Section 53a-157b of the Connecticut General Statutes and any other applicable law."

Signature of Reviewing Qualified Professional

Date: _____

Name of Reviewing Qualified Professional

License No.: _____

Affix P.E./L.A. Stamp Here

Part X: Supporting Documents

Select the applicable box below for each attachment being submitted with this registration form. When submitting any supporting documents, please label the documents as indicated below (e.g., Attachment A, etc.) and be sure to include the registrant's name as indicated on this certification form.

- Attachment A:** Select here as verification that an 8 ½" X 11" copy of the relevant portion of a USGS Quadrangle Map with a scale of 1:24,000, showing the exact location of the facility has been submitted with this registration. Indicate the quadrangle name on the map, and be sure to include the registrant's name. (To obtain a copy of the relevant USGS Quadrangle Map, call your town hall or DEEP Maps and Publications Sales at 860-424-3555)
- Attachment B:** Documentation related to *Coastal Consistency Review*, if applicable.
- Attachment C:** Threatened and Endangered Species Form and any additional information (such as a copy of a NDDB map)
- Attachment D:** Conservation or Preservation Restriction Information, if applicable.
- Attachment E:** Where applicable, non-electronic Pollution Control Plan.

Note: Please submit the fee along with a completed, printed and signed Registration Form and all additional supporting documents to:

**CENTRAL PERMIT PROCESSING UNIT
DEPARTMENT OF ENERGY AND ENVIRONMENTAL PROTECTION
79 ELM STREET
HARTFORD, CT 06106-5127**

ATTACHMENT C: THREATENED AND ENDANGERED SPECIES

Information about compliance with the requirements of Section 3(b)(2) of this general permit, regarding threatened and endangered species, is in Appendix A of the general permit. Choose one or more (if applicable) of the following in order to be eligible to register for this General Permit. A registrant who does not or cannot do so is not eligible to register under this General Permit.

- Self Assessment using the NDDDB maps – Select this only if:
- a. The site of the construction activity is not entirely, partially or within a ¼ mile of a shaded area depicted on the Department’s Natural Diversity Database maps and this determination was made not more than six months before the date of submitting this registration;
- AND
- b. The entity registering for this General Permit has no reasonably available verifiable scientific, or other credible information that the construction activity could reasonably be expected to have an adverse impact upon a federal or state species listed as threatened or endangered.

Attach a copy of the NDDDB map used to conduct the self assessment used to register for this general permit.

Note: Both a and b as used in this section, must be true in order for a Registrant to register for this General Permit using the self-assessment option. If neither is true, a Registrant cannot use the self-assessment option to comply with Section 3(b)(2) and Appendix A of the General Permit.

- Limited One-Year Determination – Select this only if:
- a. The entity registering for this General Permit has obtained a limited one-year determination from the Department’s Wildlife Division regarding threatened and endangered species: i) within a year of the date of submitting this registration; or ii) more than 1 year before submitting this registration, but such determination has been extended by the Department within one year of the date of submitting this registration;
- AND
- b. The Registrant has provided to the Department’s Wildlife Division any reasonably available verifiable scientific, or other credible information that the construction activity could reasonably be expected to have an adverse impact upon a federal or state species listed as threatened or endangered.

Provide the date the limited one-year determination was issued by the Department’s Wildlife Division _____;

or

Provide the date that the most recent extension to a limited one year determination was issued by the Department’s Wildlife Division _____.

Note: Both a and b as used in this section, must be true in order for a Registrant to register for this General Permit using the Limited One-Year Determination option. If a Limited One-Year Determination or extension to any such determination was issued by the Department’s Wildlife Division more than one year before the submission of this registration, a Registrant cannot use any such determination or extension to comply with Section 3(b)(2) and Appendix A of the General Permit.

ATTACHMENT C: THREATENED AND ENDANGERED SPECIES (continued)

- Select here if the Limited One-Year Determination issued by the Department includes a Mitigation Plan.**

Provide the date the Mitigation Plan was approved: _____

Governmental Entity Approving the Plan: _____

As of the date this Registration is submitted,

Has the Mitigation Plan been fully implemented? Yes No

Date commenced: _____ Date completed: _____

Is the Mitigation Plan partially implemented? Yes No

If yes, what actions have been taken? _____

And which actions are yet to be implemented and what is the timeframe for completion of such actions: _____

Is the Mitigation Plan yet to be implemented? Yes No

If yes, specify the timeframe for implementation: _____ to _____

And summarize actions to be implemented: _____

- Safe Harbor Determination - Select this only if:

a. The entity registering for this General Permit has obtained a Safe Harbor Determination from the Department's Wildlife Division regarding threatened and endangered species: i) within 3 years of the date of submitting this registration; or ii) more than 3 years before submitting this registration, but within one-year of a one-year extension issued by the Department's Wildlife Division to a safe harbor determination;

AND

b. The entity registering for this General Permit has provided to the Department's Wildlife Division any reasonably available verifiable scientific, or other credible information that the construction activity could reasonably be expected to have an adverse impact upon a federal or state species listed as threatened or endangered.

Provide the date the Department's Wildlife Division issued a Safe Harbor Determination: _____

If applicable, provide the date that any one-year extension to a Safe Harbor Determination was issued by the Department's Wildlife Division: _____.

Note: Both a and b as used in this section, must be true in order for a Registrant to register for this General Permit using the Safe Harbor Determination option. If a Safe Harbor Determination was issued by the Department's Wildlife Division more than three years before the submission of this registration, and has not been extended, a Registrant cannot use any such safe harbor to comply with section 3(b)(2) and Appendix A of this General Permit. If a Safe Harbor Determination was granted and extended for one-year, more than four years before the submission of this registration, a Registrant cannot use any such Safe Harbor Determination to comply with Section 3(b)(2) and Appendix A of the general permit.

ATTACHMENT C: THREATENED AND ENDANGERED SPECIES (continued)

Select here if the safe harbor noted above includes a Mitigation Plan.

Provide the date the Mitigation Plan was approved: _____

Governmental Entity Approving the Plan: _____

As of the date this Registration is submitted,

Has the Mitigation Plan been fully implemented? Yes No

Date commenced: _____ Date completed: _____

Is the Mitigation Plan partially implemented? Yes No

If yes, what actions have been taken? _____

And which actions are yet to be implemented and what is the timeframe for completion of such actions: _____

Is the Mitigation Plan yet to be implemented? Yes No

If yes, specify the timeframe for implementation: _____ to _____

And summarize actions to be implemented: _____



Connecticut Department of
Energy & Environmental Protection
Bureau of Materials Management & Compliance Assurance
Water Permitting & Enforcement Division

Instructions for Completing the General Permit Registration Form for the Discharge of Stormwater and Dewatering Wastewaters from Construction Activities (Issued 08/21/13, effective 10/1/13 (non-electronic form))

Use these instructions to complete the registration form for the General Permit for the Discharge of Stormwater and Dewatering Wastewaters from Construction Activities (DEEP-WPED-REG-015). These instructions are not a substitute for the requirements of any relevant statutes or regulations. You should review all applicable laws prior to completing the registration form. Remember, it is your responsibility to comply with all applicable laws.

A completed registration form must be submitted for each site conducting construction activity regulated by this permit. Please note that the submission of a permit transmittal form is not necessary.

Introduction

The Water Permitting and Enforcement Division of the Department of Energy and Environmental Protection's (DEEP) Bureau of Materials Management and Compliance Assurance uses both individual and general permits to regulate stormwater discharges. Individual permits are issued directly to an applicant, whereas general permits are permits issued to authorize similar activities by one or more registrants throughout a prescribed geographic area. Authorization of an activity under a general permit is governed by that general permit. A general permit sets terms and conditions for conducting an activity which, when complied with, are protective of the environment. General permits are a quicker and more cost effective way to permit specific activities for both the department and the applicant. Any questions regarding this general permit should be directed to 860-424-3018.

Who May Apply for General Permit Authorization?

With the exception noted in the "Small Construction" section (Section 3(d)) of this general permit, any person or municipality that initiates, creates, originates or maintains a discharge described in the "Eligible Activities" section (Section 3(a)) of this general permit shall file with the commissioner a registration form that meets the requirements of the "Contents of Registration" section (Section 4(c)) of this general permit (or a re-registration form) and the applicable fee within the timeframes and in the amounts specified in Sections 3(c) and 4(c)(1)(A), respectively. Any such person or municipality filing a registration remains responsible for maintaining compliance with this general permit.

How to Apply

Your general permit registration must include the following:

- an original *General Permit Registration Form for the General Permit Registration Form for the Discharge of Stormwater and Dewatering Wastewaters from Construction Activities* (DEEP-WPED-REG-015) that is electronically filled out, printed, and signed, and

- all necessary supporting documents attached (Attachments A-E), and
- the applicable fee, paid by check or money order, made payable to the “Department of Energy and Environmental Protection”.

You must submit the above materials together as a package to:

CENTRAL PERMIT PROCESSING UNIT
 DEPARTMENT OF ENERGY AND ENVIRONMENTAL PROTECTION
 79 ELM STREET
 HARTFORD, CT 06106-5127

When submitting your general permit registration, label your supporting documents as directed on your registration form and always include, on each document, the registrant's name. When additional space is necessary to answer a question stated in the registration, please attach additional sheets to the Registration Form. Label each sheet with the registrant’s name as indicated on the *Registration Form*, along with the corresponding part number and question number indicated on the general permit registration form. You should retain a copy of all documents for your files.

Part I: Registration Types and Timelines

Select the appropriate box to specify if the registration is for a re-registration with an existing permit, a new registration that is for a locally approvable project (see definition in Permit), a new registration that is for a locally exempt project or a modification of an existing authorization under the General Permit. If this is a re-registration, identify the previous or existing permit number in the space provided. Note that stormwater discharges are typically authorized by a 9 digit permit number starting with one of the following prefixes: GSN or GSW. If this is a new registration select either locally approvable or exempt project, provide the size of soil disturbance, and select the appropriate timeline. If this is a modification of an existing authorization under the General Permit, identify the existing permit number in the space provided and select the appropriate timeline for registration from the options listed in the Registration Timeline box.

If there are any changes or corrections to your company/facility or individual name, mailing or billing address or contact information, please complete and submit the [Request to Change Company/Individual Information](#) to the address indicated on the form. For any other changes, you must contact the specific program from which you hold a current DEEP Permit. If there is a change in ownership, please contact the Permit Assistance Office for questions concerning license transfers at 860-424-3003.

Part II: Fee Information

A registration fee must be submitted for each registration you are submitting. Refer to the criteria below to determine the appropriate fee for your activity.

❖ New Registrations

- Locally approvable projects (registration only):
 - \$625
- Locally exempt projects (registration and Plan):
 - \$3,000 total (soil disturbance area ≥ one (1) and < twenty (20) acres).

- \$4,000 total (soil disturbance \geq twenty (20) acres and $<$ fifty (50) acres).
- \$5,000 total (soil disturbance \geq fifty (50) acres).

❖ Re-Registrations

- \$625 (sites previously registered prior to September 1, 2012)
- \$0 (sites previously registered between September 1, 2012 and the issuance date of this permit)

❖ Modifications

- \$0

The fees for municipalities shall be half of those indicated in subsections 1.a., 1.b., and 2 above pursuant to Section 22a-6(b) of the Connecticut General Statutes. State and Federal agencies shall pay the full fees specified in this subsection. The registration will not be processed without the fee. The fee shall be non-refundable and shall be paid by certified check or money order payable to the Department of Energy and Environmental Protection.

Part III: Registrant Information

1. Registrant/Client Name:

- Provide the full, legal company/firm name. If identifying an entity registered with the Secretary of the State, fill in the name exactly as it is shown on such registration and provide the Secretary of State Business ID Number. If identifying an individual, provide the full legal name (include title and suffix) in the following format: Title (Ms, Dr, etc.); First Name; Middle Initial; Last Name; Suffix (Jr, Sr., II, III, etc.) .
 - Select one of the following “*Registrant Types*” from the drop down: Individual, Business Entity, Federal Agency, State Agency, or Municipality.
 - Select one of the following “*Business Types*” from the drop down: Corporations, Limited Liability Companies-LLC, Limited Liability Partnerships-LLP, Limited Partnerships-LP, Partnerships (General Partnerships-GP), Statutory Trusts, other (if other, specify type in the space provided) or N/A (non-applicable).
 - Provide your Secretary of the State business ID number (if applicable). This information can be accessed at [CONCORD](#).
 - Provide the mailing address including the street address, city/town, state, and zip code.
 - Provide a business phone number where the registrant’s contact person can be contacted during the daytime business hours.
 - Provide the name and title of the specific individual (Contact Person) within the company whom DEEP may contact.
 - Provide an accurate company email address. The email address may be used for future correspondence from the DEEP to your business.
 - If applicable, provide an additional phone number, other than the one provided as the “Business Phone”, where the contact person can also be contacted.
2. If different than the registrant, provide specific contact information for billing matters.
 3. If different than the registrant, provide specific information for the primary or on-site contacts.
 4. If different than the registrant, provide specific information for the owner of the property on which the activity will take place.
 5. If different than the registrant, provide specific information for the developer.

6. If different than the registrant, provide specific information for the general contractor.
7. If different than the registrant, provide specific contact information for any engineer(s) or other consultant(s) employed or retained to assist in preparing the registration and/or Stormwater Pollution Control Plan. Provide your Secretary of the State business ID number (if applicable). This information can be accessed at [CONCORD](#).
8. If different than the registrant and a locally approvable project, provide specific information for the Reviewing Professional.

Part IV: Site Information

DEEP strongly encourages all registrants to conduct a review of the following including Coastal, Natural Diversity Data Base and Aquifer Protection information as soon as possible to resolve any outstanding issues, where feasible, before submitting their general permit registration to DEEP to ensure a more timely and efficient review of their general permit registration.

1. Name of Site:

This should be the name by which the site is commonly known and/or uniquely identified. The information given as the “Street Address or Location Description should be the address of the property at which the activity/proposed activity takes place. Include the street address and municipality. If the property does not have a street number, describe the location in terms of the distance and direction from an obvious landmark such as an intersection with another roadway, a bridge, or a river. For example, “on River Street, approximately 1000 feet north of its intersection with Bear Swamp Road”. Provide a brief description of the construction activity including the project start date, anticipated completion date and the normal working hours.

2. **Mining:** Select yes, if the site in question has activity which is part of mining operations. If you answered “yes”, mining is not authorized by this general permit. You must submit the Registration Form for the General Permit for the Discharge of Stormwater Associated with Construction Activity.
3. **Combined or Sanitary Sewer:** Select yes, if **all** of the stormwater from the proposed activity discharge to a combined or sanitary sewer (i.e. a sewage treatment plant). If you answered “yes”, this activity is not regulated by this permit. Contact the Water Permitting & Enforcement Division at 860-424-3018.
4. **Indian Lands:** Select the appropriate box to specify if the facility is or will be located on federally recognized Indian lands.
5. **Coastal Boundary:** Activities within the state's coastal area must be consistent with the Connecticut Coastal Management Act, i.e., sections 22a-90 through 22a-112 of the Connecticut General Statutes (CGS). You may be required to complete a *Coastal Consistency Review Form* (DEEP-APP-004) to demonstrate that the activity is consistent with the standards and policies of the Connecticut Coastal Management Act.

To determine whether this requirement pertains to you, you must first determine if your activity is, or is proposed to be, located in either the coastal area or the coastal boundary.

- The *coastal area*, as defined in CGS section 22a-94 (a), includes the land and water within the following towns: *Branford, Bridgeport, Chester, Clinton, Darien, Deep River, East Haven, East Lyme, Essex, Fairfield, Greenwich, Groton (City and Town of), Guilford, Hamden, Ledyard, Lyme, Madison, Milford, Montville, New London, New Haven, North Haven, Norwalk, Norwich, Old Lyme, Old Saybrook, Orange, Preston, Shelton, Stamford, Stonington (Borough and Town of), Stratford, Waterford, West Haven, Westbrook, and Westport.*

- The *coastal boundary*, as defined in CGS section 22a-94(b), is a designated region within the coastal area. It is delineated on DEEP-approved coastal boundary maps which are available for review at the DEEP Office of Long Island Sound Programs (OLISP), the DEEP File Room, and municipal offices of towns located in the coastal area. Copies of these maps may also be purchased from DEEP Maps and Publications. The map can also be viewed at: www.cteco.uconn.edu/map_catalog.asp.

Activities within the coastal boundary-

If your proposed activity will be located in the coastal boundary and you are applying for a new authorization under a general permit, you must select “yes” in the registration form and attach the coastal management Act Determination form(found in Appendix d of this general permit) to you registration form as Attachment B.

For renewals or modifications of existing authorizations for activities located within the coastal boundary, you are not required to submit information on CT Coastal Management Act requirements with your initial registration materials. However, DEEP may notify you that submission of the Coastal Consistency Review Form is required to process your registration depending upon the specific activities to be conducted and their potential impact on coastal resources.

Activities outside the coastal boundary but within the coastal area-

For general permit registrations for activities located outside of the coastal boundary, but within a town in the coastal area, you should select “no” in the registration form. You are not required to submit a *Coastal Consistency Review Form* with your initial registration materials. However, DEEP may notify you that submission of this form is required to process your registration depending upon the specific activities to be conducted and their potential impact on coastal resources.

- 6. Endangered or Threatened Species:** In order to be eligible to register for this General Permit, each registrant must perform a self-assessment, obtain a limited one-year determination, or obtain a safe-harbor determination regarding threatened and endangered species. This may include the need to develop and implement a mitigation plan. While each alternative has different limitations, the alternatives are not mutually exclusive; a registrant may register for this General Permit using more than one alternative. See Appendix A of the General Permit. Each registrant must complete this section AND Attachment C to this Registration form. A registrant who does not or cannot do so is not eligible to register under this General Permit.

Each registrant must perform a review of the Department’s Natural Diversity Database maps to determine if the site of the construction activity is located within or in proximity (within ¼ mile) to a shaded area. Refer to “Requests for Natural Diversity Data Base State Listed Species Reviews” located on the DEEP website at: www.ct.gov/deep/nddbrequest to determine if your activity is located within an area identified as a habitat for listed species. Print a copy of the NDDB map you viewed and attach it to the Registration Form. In addition to the map printout, you must complete and attach Attachment C of the Registration Form and complete question 6.a and 6.b.

- 7. Wild and Scenic Rivers:** At this time, the only designated wild and scenic rivers are the West Branch of the Farmington River and the Eight Mile River. Please refer to Appendix H of the general permit for further guidance.
- 8. Aquifer Protection Areas:** The following DEEP link, [Aquifer Area Maps](#), provides the list of towns and maps and information to determine if your activity may be regulated either by the local aquifer protection agency or the DEEP Aquifer Protection Program. For further assistance, you may call the Aquifer Protection Program at 860-424-3020. For additional guidance, please refer to Appendix C of the General Permit.

9. **CT Guidelines for Soil and Erosion and Sediment Control:** For guidance, please refer to [2002 Connecticut Guidelines for Soil Erosion and Sediment Control](#).

10. **Historic and/or Archaeological Resources:** For guidance, refer to Appendix G of the general permit.

11. Conservation or Preservation Restriction:

Select the appropriate box based on whether or not the subject site has a conservation or preservation restriction. Use local land records to obtain this information.

PART V: Stormwater Discharge Information

Table 1 – Outfall Information

An outfall is each point source discharge of stormwater from your site. The number and location of outfalls may change during construction. Table 1 is a list of outfalls at the start of construction.

Outfall Number:

Each outfall should have a distinct number identifier and should be listed as designated in your Pollution Control Plan.

a) Type:

From the dropdown menu available, select the type of conveyance: pipe, swale, or other (if other, specify the type in the space provided).

b) Pipe Material:

From the dropdown menu available, select the material of the conveyance: concrete, metal, and clay, plastic, other (if other, specify the material in the space provided) or not applicable. If your discharge is not conveyed through a pipe, select “not applicable” here.

c) Pipe Size:

From the dropdown menu available, please select the size of the conveyance: 3”,4”, 6”,8”,10”,12”,15”, 18”, 24”, 36”, 42”, 48”,54”, 60”, 72”, 84”, 90”, 96”, or other (if other, specify the size in the space provided) or not applicable.

d) Latitude/Longitude:

A decimal format is required here for this table. If the latitude and longitude numbers given are outside of Connecticut’s boundaries, an error message will appear. If you used another method besides CT ECO and need to convert coordinates from degrees, minutes, seconds format to decimal format, use the formula below.

degrees + (minutes/60) + (seconds/3600)

For example, to convert 42deg, 08min, 10sec into decimal format: **42 + (8/60) + (10/3600) = 42.1361**

Access the CT ECO webpage to find the latitude and longitude for each outfall at:

<http://ctecoapp1.uconn.edu/simpleviewer/ezviewer.htm>.

The following explains how to navigate CT ECO.

1. On this webpage, a map of Connecticut will appear on the screen. To the left of the map will be a large box that labeled at the top “Choose a Map Theme” (See Figure 1).
2. There are five grey boxes listed at the bottom of this box. Select on the first box that reads “Find an Address”.
3. Fill in the street address or intersection, town and zip code of the site location and select “Locate” (See Figure 2).

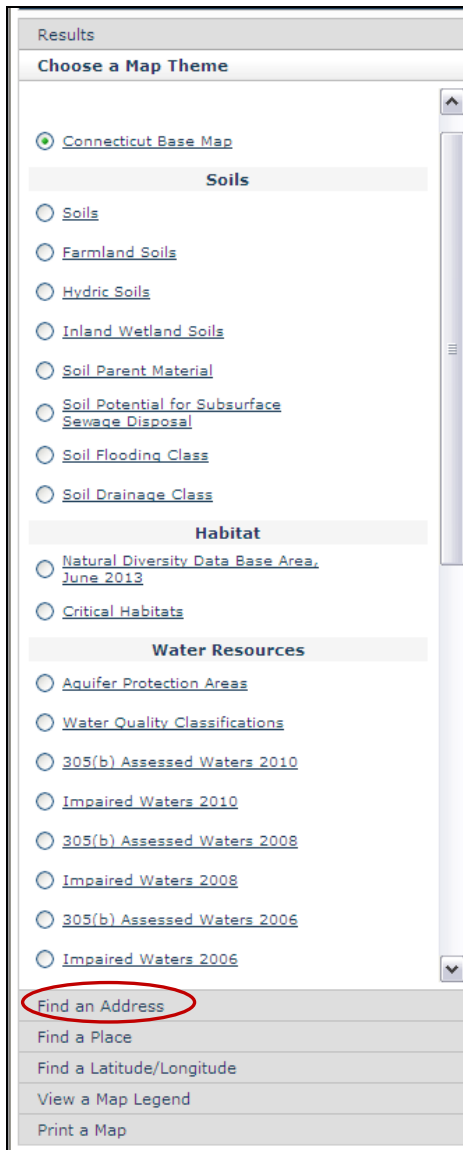

(Figure 1)

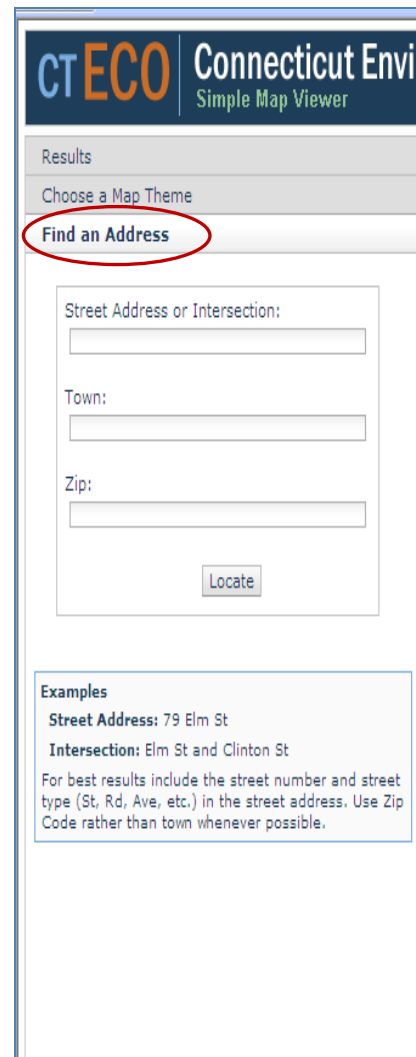
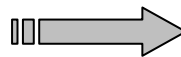

(Figure 2)

4. To find your outfall location, first click on the “Choose a Photo Base” dropdown menu located in the top center of the page. Then choose the most up to date map option (see Figure 3).
5. Use the zoom bar located in the top left hand corner. To zoom in closer, move the white box upward and to zoom out, move it downward. Zoom in to map scale 1:3,000 so that you can approximate the location of your outfall(s).
6. Hold the cursor over each outfall location and note the latitude/longitude coordinates found at the bottom right hand corner of the page.

(Figure 3)

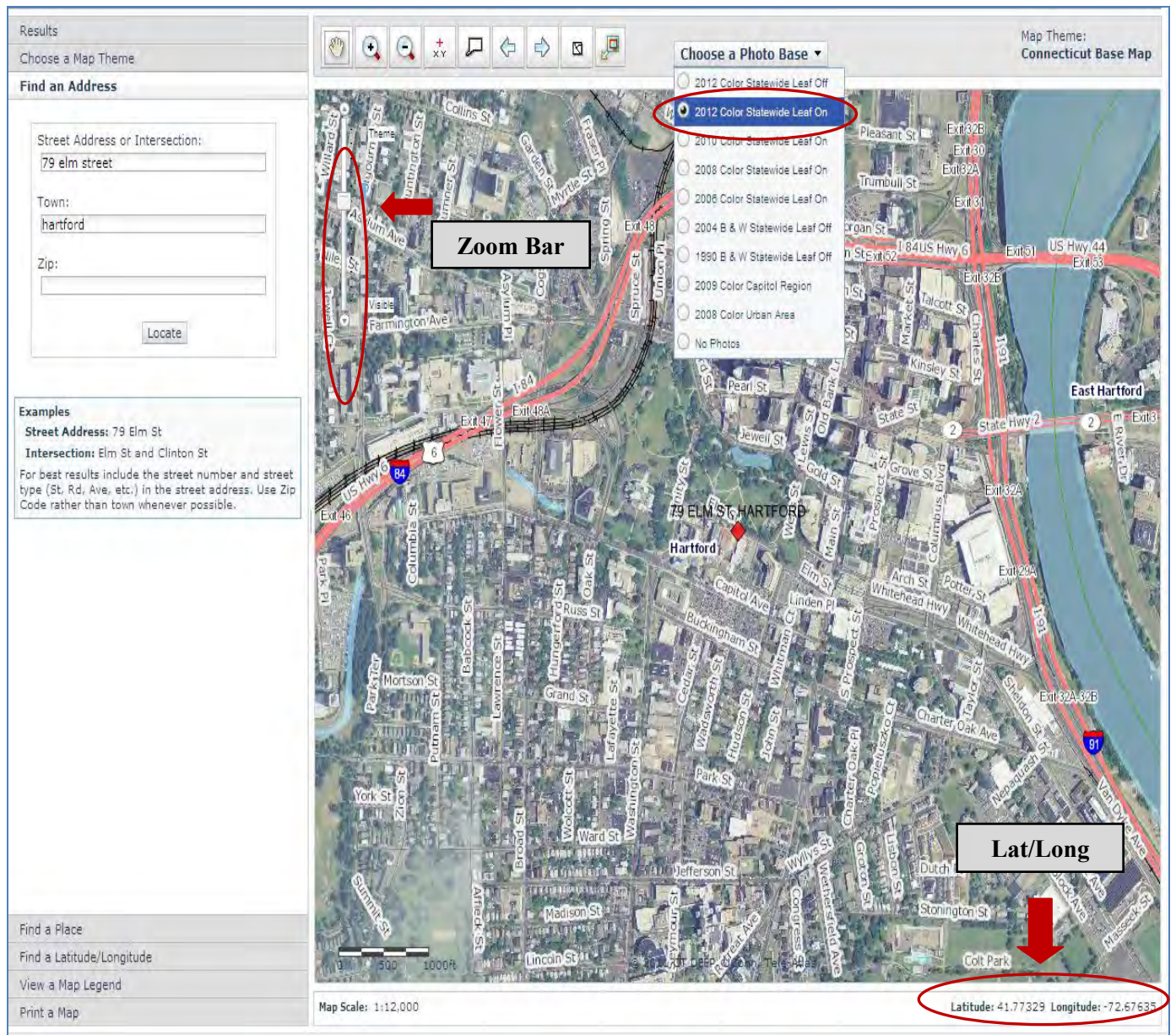

e) Select which method was used to obtain your latitude/longitude information: CT ECO, GPS, or other.

Table 2

Outfall Number:

Each outfall should have a distinct number identifier and should be listed as designated in your Pollution Control Plan.

- a) For temporary and permanent outfalls, provide a start date. For temporary discharges, also provide a date the discharge will cease.
- b) For the drainage area associated with each outfall, provide the amount (in square feet) of Effective Impervious Area Before Construction.
- c) For the drainage area associated with each outfall, provide the amount (in square feet) of Effective Impervious Area After Construction.
- d) Provide the system or receiving water in which your stormwater runoff discharge? either “storm sewer” or wetlands/waterbody”
(If you select “storm sewer” proceed to Part VI of the form. If you select “wetlands/waterbody” proceed to next question)
- e) For each outfall, does it discharge to any of the following towns: Branford, Kent, Manchester, Meriden, North Branford, Norwalk or Wilton (If no, proceed to Part VI of the form. If yes, proceed to next question.)
- f) For each outfall, does it discharge to a “freshwater” or “saltwater”? (If you select “freshwater” proceed to Table 3. If you selected “saltwater”, proceed to Part VI of the form.)

Table 3 – Follow the steps below *only* if your outfall discharges to a freshwater wetlands/ or waterbody in Branford, Kent, Manchester, Meriden, North Branford, Norwalk, or Wilton.

To find the ID #'s required in question a) of Table 3, follow the instructions given below step by step. Each outfall number may have a different ID number. Each ID number will be based on your outfall location. Provide a 305b ID # (water body ID#) for each outfall.

Outfall #: In the first column of the table, list the outfall number of the discharge and the location of your stormwater discharge. Each outfall should have a distinct number identifier and should be listed as designated in your Pollution Control Plan.

- a) Follow these step by step instructions below to determine each outfall's 305b #

Step 1: Go to the CT ECO website: <http://ctecoapp1.uconn.edu/advancedviewer/>

Step 2: A map of Connecticut will open in your browser.

Step 3: Next locate your site on the map: search by any of the following: site address, an address in close proximity of the site in question or by town.

To search by town:

- Select “find a town” tab located in the top left portion of the screen.
- Select the town in which the site in question is located. To adjust the map, use the “pan” and “zoom” tools in the top right corner of the page.
- Zoom in until local features are visible such as streets and roads. If you zoom too far select the “back extent” arrow to go back to the previous view.
- To move the map, use the pan tool to grab and adjust.

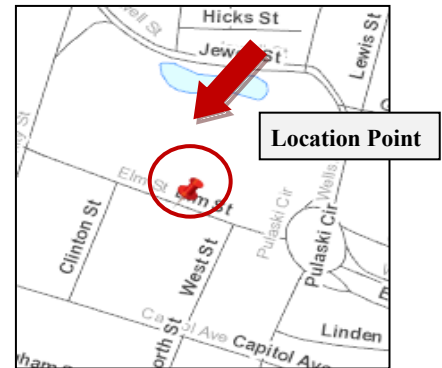
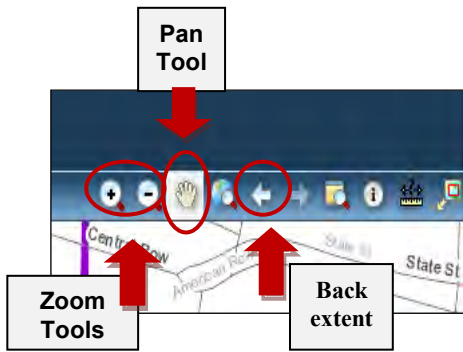

Or

To search by address:

- Select “Find an Address” on the top left hand corner of the page and type in your street address in the box titled “Street or Intersection” and your town name in the “Zone” box.
- Once you select “Find”, CT ECO will place a red pushpin on the map at your location.
- The “Results” section contains the results of your search. If other unwanted addresses show up on the list here, unselect them.
- To adjust the map, use the “pan” and “zoom” tools in the top right corner of the page. Zoom in until local features are visible such as streets and roads. If you zoom too far select the “back extent” arrow to go back to the previous view. To move the map, use the pan tool to grab and adjust.

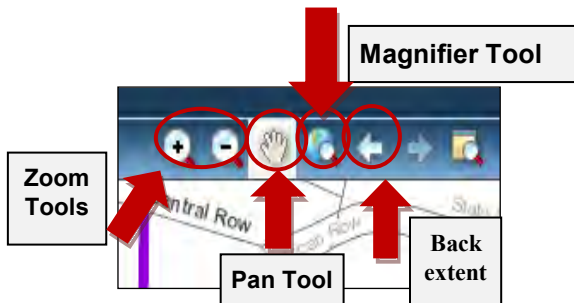
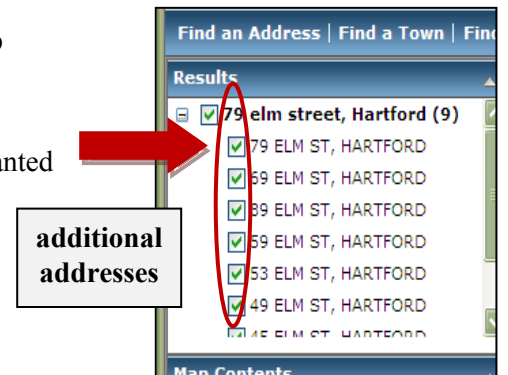

Select these 4 boxes

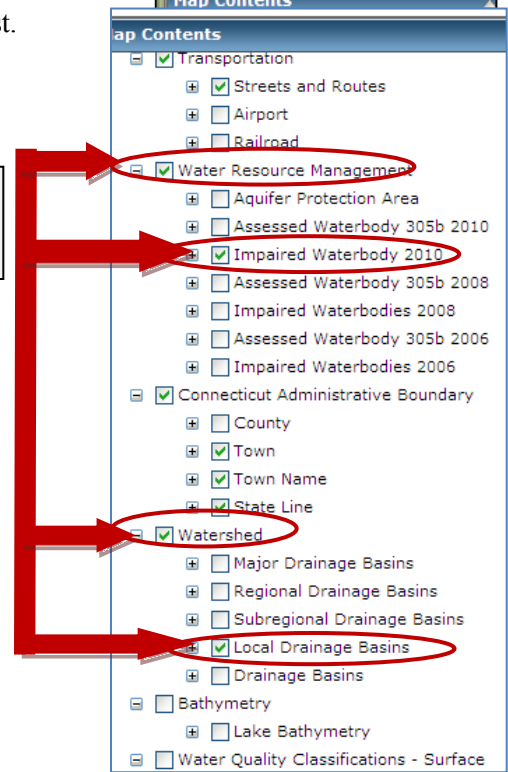

Step 4: In the “Map Contents” section on the left side of the screen, scroll down to “Water Resource Management” select this and the most recent Impaired Waterbody list below it. Also scroll to find “Watershed”, select “Watershed” and “Local Drainage Basins” below that.

Step 5: In the “Map Contents” section on the left side of the screen, scroll down to the “Imagery and Topo” and select this and the most recent NAIP Infrared Orthophotography option.

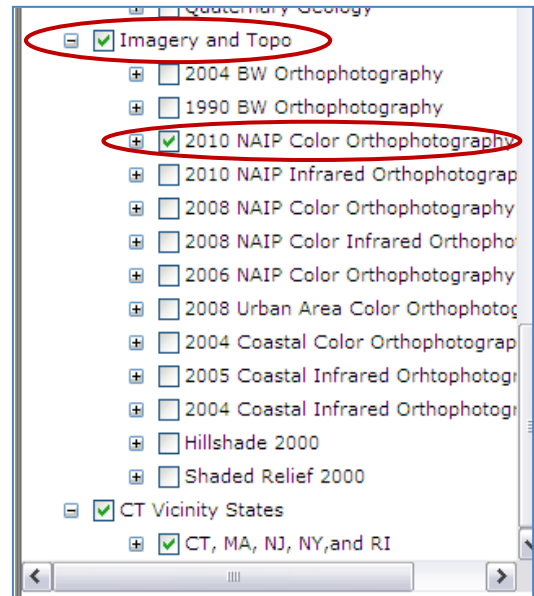

Step 6: Use the magnifier tool at the top of the page to help find the 305b ID #. Once you select the magnifier tool symbol, grab the top blue section of the box and drag the box so that it appears over the outfall location, and then release.

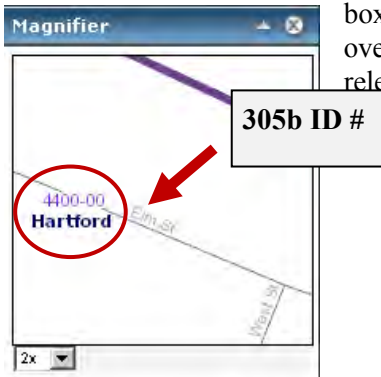

Step 7: The hyphenated six digit purple number in the box is the 305b ID # that you will report on the registration form.

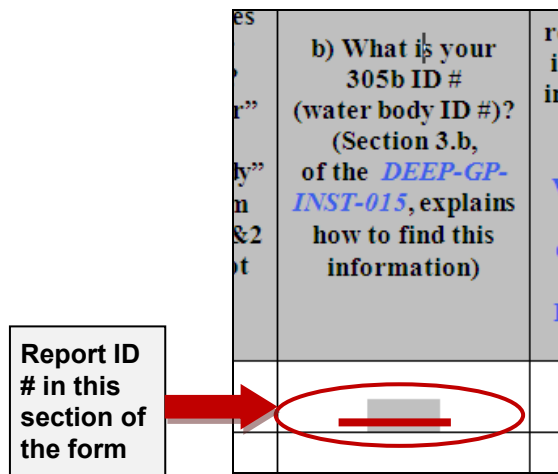

If you have any questions please email Carol Papp at: carol.papp@ct.gov.

b) Compare your 305b # with the 305b #'s provided on the following table: “Impaired Waters Table for Construction Stormwater Discharges”. If your number is found on this list, select yes and proceed to next question. If your number is not found on this list, select no and proceed to Part VI of the form. If you answered yes to Table 3 question b), verify the project’s Pollution Control Plan (Plan) includes at least one of following control measures. Confirm compliance by selecting the control measure that applies: No more than 3 acres is disturbed at any time, OR Stormwater runoff from a 2 yr, 24 rain event is retained.

c) Refer to the last column, labeled “Approved TMDL”, of the back to the “Impaired Waters Table for Construction Stormwater Discharges” to determine if the impaired waterbody has an approved Total Maximum Daily Load (TMDL).

Part V: Stormwater Discharge Information (continued)

Questions 1 & 2- Impaired waters: If you answered “yes” to Table 3, question b., you must answer Question 1 or Question 2. Question 1.a. or 1.b. must be answered if the receiving water is impaired, but does not have a TMDL. For receiving waters with a TMDL, answer questions 2.a. and 2.b. and either 2.c.1 or 2.c.2.

Part VI: Pollution Control Plan: You must select one of the four options listed. If you are providing a Plan, select whether the Plan will be attached to your registration form or a URL address for an electronic Plan will be given.

Part VII: Registrant Certification

After the registration has been completed it must be reviewed for completeness and signed by both the registrant and the individual(s) who actually prepared the registration, (e.g. consultants, professional engineers, surveyors, soil scientists, etc.). By their signature, they certify that, to the best of their knowledge and belief, the information contained in the registration, including all attachments, is true, accurate, and complete. Provide the legal name of registrant and address of the project or activity.

The certification of the registration package shall be signed as follows:

1. For an individual(s) or sole proprietorship: by the individual(s) or proprietor, respectively;
2. For a corporation: by a principal executive officer of at least the level of vice president, or his/her agent;
3. For a limited liability company (LLC): by a manager, if management of the LLC is vested in a manager(s) in accordance with the company’s “Articles of Organization”, or by a member of the LLC if no authority is vested in a manager(s);
4. For a partnership: by a general partner;
5. For a municipal, state, or federal agency or department: by either a principal executive officer, a ranking elected official, or by other representatives of such registrant authorized by law.

A registration will be considered insufficient unless all required signatures are provided.

Part VIII: Professional Engineer (or Landscape Architect, where appropriate) Design Certification (for locally approvable and exempt projects).

This certification must be signed by a Professional Engineer or Landscape Architect where appropriate. Include your appropriate qualification, registrant’s legal name, and the address of the project or activity. The design professional needs to sign, date and provide their license number along with a P.E./L.A stamp.

Part IX: Reviewing Qualified Professional Certification

For Review certification by Conservation District:

Provide the name of the associated conservation district, legal name of registrant and address of which the project or activity. Where appropriate, the district professional must sign, date, and provide a license number.

Or

For Review certification by Qualified Professional:

Provide the company that employs the Qualified Professional, the professional legal name and license number.

The professional must sign, date, and provide a license number.

For additional guidance related to the level of independence of the Qualified Professional refer to Section 3(b)(11) of the general permit.

Level of independency of a professional:

For projects between 1-15 acres of site disturbance, verify statements 1 and 2.

For projects with 15 or more acres of site disturbance, verify statements 1-4.

Part X: Supporting Documents

A list of attachments required to be submitted with this registration will be automatically generated based on the information you provide in the e-form and listed on the Supporting Documents/Summary page. Each attachment on the list is required to be submitted with this registration form. When submitting any supporting documents, please label the documents as indicated below (e.g., Attachment A, etc.) and be sure to include the registrant's name as indicated on the registration form.

Attachment A: United States Geological Survey (USGS) Quadrangle Map

Submit, a 8 ½" x 11" copy of the relevant portion of a USGS Quadrangle Map, at a scale of 1:24,000, indicating the exact location of the project site and proposed activities.

The quadrangle name should be noted on the copy of the map submitted. See Figure A at the end of these instructions for an example of how a USGS map must be labeled when submitted.

DEEP will use this map to enter your project location into its Geographic Information System (GIS). It is important that you accurately locate the project site and proposed activities because the GIS generates natural resource information relevant to your site. An inaccurate description of the project location may delay the processing of your registration.

Attachment B: Coastal Consistency Review Form

Activities within the state's coastal area which includes the coastal boundary must be consistent with the Connecticut Coastal Management Act (CGS sections 22a-90 through 22a-112). You may be required to complete a *Coastal Consistency Review Form* (DEEP-APP-004) to demonstrate that the activity is consistent with the standards and policies of the Connecticut Coastal Management Act.

Attachment C: CT NDDB Information

Submit copies of any correspondence provided to or received from the CT NDDB program, including a copy of a completed *CT NDDB State Listed Species Review Form* (DEEP-APP-007) as explained in Part IV, Item 6 of these instructions.

Attachment D: Conservation or Preservation Restriction

If the property is subject to a conservation or preservation restriction, submit proof of a written notice of this registration to the holder of such restriction or a letter from the holder of such restriction verifying that this registration is in compliance with the terms of the restriction. Use local land records to obtain this information.

Attachment E: Pollution Control Plan

Where applicable, Pollution Control Plan.

Available Resources:

Below is a list of possible resources for specific information required for this registration. Be sure to also check the DEEP website, www.ct.gov/DEEP and your local town hall or library for maps and other reference materials.

Both the DEEP Maps and Publications 860-424-3555 and the DEEP File Room 860-424-4180 are located on the store level at 79 Elm Street, Hartford, CT. Please call the appropriate office in advance for hours of operation.

For general assistance regarding stormwater and all wastewater discharges, contact the Water Permitting and Enforcement Division at 860-424-3018. For the subject general permit, registration form, instructions and other required documents visit the DEEP website at: www.ct.gov/DEEP/stormwater

- Coastal Boundary Areas: Town Hall and/or DEEP Maps and Publications; "Coastal Boundary Map": www.cteco.uconn.edu/map_catalog.asp
Additional information: Office of Long Island Sound Programs: 860-424-3034
- Coastal Resource Maps: Town Hall and/or DEEP Maps and Publications 860-424-3555
- USGS Topographic Quadrangle Map: (USGS) [Topographic Quadrangle Map: \(www.ct.gov/DEEP/gis\)](http://www.ct.gov/DEEP/gis); DEEP Maps and Publications, 860-424-3555, or USGS Office, 303-202-4700, or US Geological Survey, Western Distribution Branch, Box 25286, Denver Federal Center, Denver, CO 80225 (sells USGS maps and publications) www.usgs.gov
- DEEP's Environmental Equity Policy, Environmental Justice Program, Environmental Justice Public Participation Guidelines: 860-424-3044 www.ct.gov/DEEP/environmentaljustice
- Tidal Wetland Boundary Maps: DEEP Maps and Publications 860-424-3555
www.ct.gov/DEEP/gisdata
- Coastal Policies and Use Guidelines (Planning Report 30): DEEP OLISP 860-424-3034
- Wetlands of Connecticut: DEEP Maps and Publications 860-424-3555
- National Wetland Inventory Maps: DEEP Maps and Publications 860-424-3555
- 2002 Connecticut Guidelines for Soil Erosion and Sediment Control
www.ct.gov/DEEP/soilerosionsedimentcontrol
- Drainage Basins: DEEP Maps and Publications, "Natural Drainage Basins in Connecticut",

1988; www.ct.gov/DEEP/gisdata

- Land Conservation Areas: Town Hall and/or DEEP Maps and Publications; “Open Space Map”
- State and federal statutes and regulations are available for review at various locations:

On the web:

- State Statutes: www.cga.ct.gov/asp/menu/Statutes.asp
- DEEP website for Statutes and Regulations: www.ct.gov/DEEP/laws-regs
- US EPA website for Federal Laws, Regulations (Code of Federal Regulations; CFR), Policy, Guidance and Legislation: www.epa.gov/lawsregs

Book Format:

- State Library (Hartford)
- University Law Schools (UCONN-Hartford, Yale)
- Superior Courthouse Libraries (located throughout the state)
- Town Halls and Libraries (statutes)

The Connecticut Department of Energy and Environmental Protection is an Affirmative Action/Equal Opportunity Employer that is committed to complying with the requirements of the Americans with Disabilities Act (ADA). Please contact us at (860) 418-5910 or deep.accommodations@ct.gov if you: have a disability and need a communication aid or service; have limited proficiency in English and may need information in another language; or if you wish to file an ADA or Title VI discrimination complaint.

Figure A: “ABC Manufacturing-Site and Stormwater Discharge Information”

USGS Quadrangle Map: Clinton

Map Scale: 1:24,000 (1"=2,000')

* Please include Latitude and Longitude for these locations in your application.

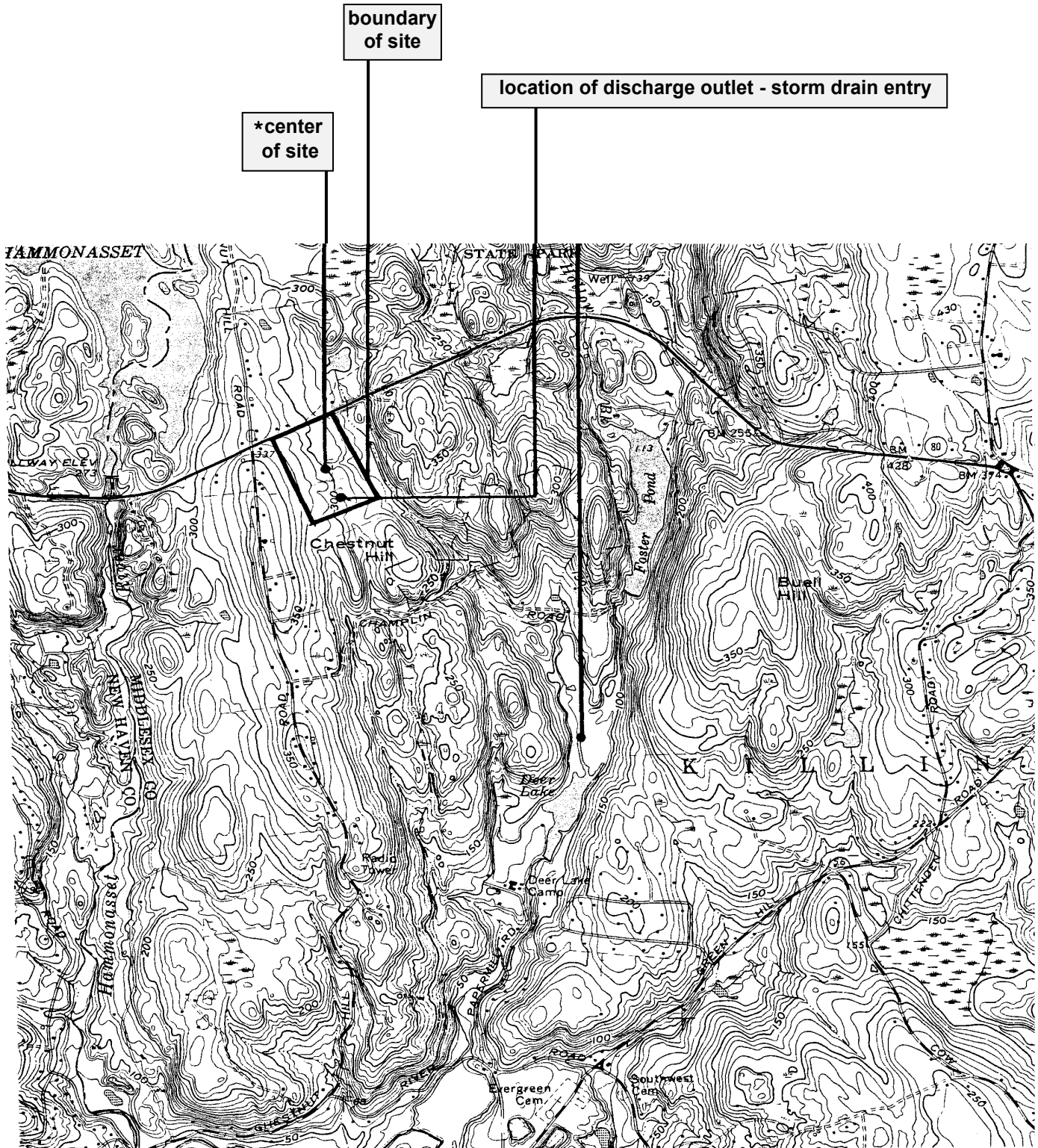

Complete URL Links Found in General Permit Registration:

Part I:

DEEP staff email address

DEEP.stormwaterstaff@ct.gov

Part III:

1. The Secretary of the State - Concord

www.concord-sots.ct.gov/CONCORD/index.jsp

Part IV:

5. Coastal Boundary

www.cteco.uconn.edu/map_catalog.asp

6. Endangered Species: Natural Diversity Data

www.ct.gov/DEEP/endangeredspecies

8. Aquifer Protection Areas

www.ct.gov/DEEP/aquiferprotection

Part V:

Table 1 d) Latitude and Longitude - CT ECO Simple Viewer

ctecoapp1.uconn.edu/simpleviewer/ezviewer.htm

Table 3 b) www.ct.gov/DEEP/stormwater

Appendix J - Site Development Plans

LOT 9
ALGONQUIN GAS TRANSMISSION, LLC
VOL. 332, P. 1093

LEGEND

- PROPERTY LINE
- EXISTING CONTOUR
- PROPOSED CONTOUR
- PROPOSED SPOT ELEVATION
- TREE LINE
- PROPOSED STORM DRAINAGE
- WETLAND LINE
- WETLAND FLAG
- WETLANDS AREA
- EASEMENT
- EXISTING FENCE
- PROPOSED FENCE

NOTES

1. TOPOGRAPHICAL MAPPING, PROPERTY SURVEY AND EXISTING FEATURES ARE BASED ON A SURVEY PREPARED BY RIORLAND LAND SURVEYING DATED 5/10/14.
2. WETLANDS LOCATIONS AS SHOWN WERE FLAGGED BY DEAN GUSTAFSON, SOIL SCIENTIST AND LOCATED BY RIORLAND SURVEYING.
3. VERTICAL DATUM IS NAVD83.
4. HORIZONTAL DATUM IS NAD83/87 COORDINATE SYSTEM.

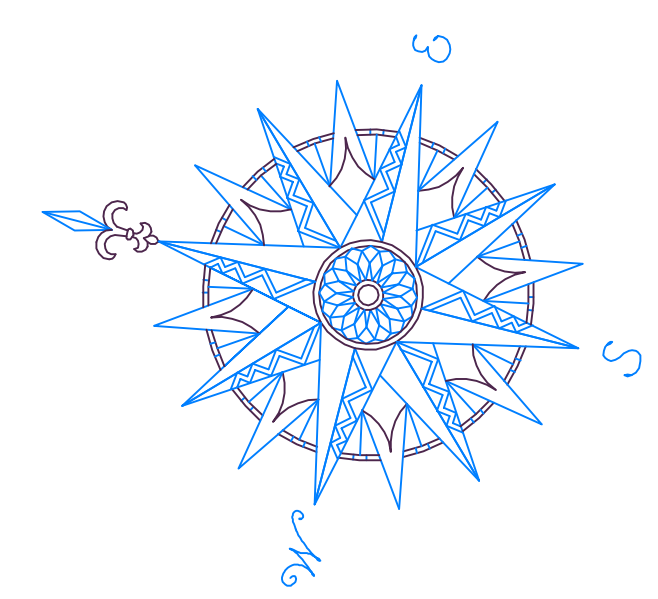

NO.	REVISION	DATE
1	REV. PER SITING COUNCIL REVIEW	02 FEB 15
2	RIPRAP PAD ADDED	18 FEB 15
3	REV. PER CT DEEP REVIEW	24 FEB 15

Previous Editions Obsolete

LEGEND-POWER PLANT

1. STACK
2. HRSG
3. AQUEOUS AMMONIUM STORAGE TANK/UNLOADING AREA
4. BLOWDOWN TANK
5. AUXILIARY COOLING SYSTEM FAN COOLER
6. AIR COOLED CONDENSER
7. DEMINERALIZED WATER TRAILERS
8. DEMINERALIZED WATER STORAGE TANKS/PUMP HOUSE (TWO (2) TANKS EACH 875,000 GAL.)
9. FIRE/SERVICE WATER STORAGE TANK & PUMP HOUSE
10. COMBUSTION TURBINE GENERATOR
11. CTG STEP-UP TRANSFORMER
12. ISOLATION TRANSFORMER/ EXCITATION TRANSFORMER
13. CONTROL HOUSE
14. SWITCHYARD
15. GAS METERING STATION
16. ELECTRICAL/BATTERY DIESEL GEN. ROOMS GND FLR
17. STEAM TURBINE GENERATOR WITH ENCLOSURE
18. GAS HEATER/FILTER AND METERING
19. STORM WATER DETENTION POND
20. CONDENSATE STORAGE TANK
21. FIRE PROTECTION FOAM SYSTEM ENCLOSURE
22. ACC MECHANICAL/ELECTRICAL BUILDING
23. FUEL OIL STORAGE TANK WITH SECONDARY STEEL CONTAINMENT (1,500,000 GAL.)
24. FUEL OIL UNLOADING AREA
25. FUEL OIL FORWARDING PUMP/HEATER/FILTER SKID
26. CEMS ENCLOSURE
27. HRSG CHEM FEED
28. BOILER FEED WATER PUMPS
29. AUXILIARY BOILER ROOM (GROUND FLOOR)
30. EMERGENCY DIESEL GENERATOR ROOM
31. LOAD COMMUTATING INVERTER (LCI) COMPARTMENT
32. COLD LINK REACTOR
33. GENERATOR EXCITATION COMPARTMENT
34. STG STEP-UP TRANSFORMER
35. EQUIPMENT REMOVAL AREA

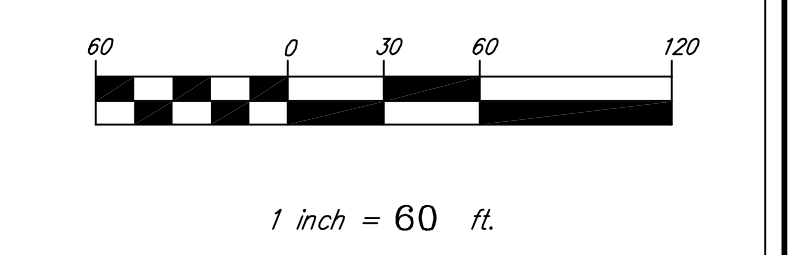

STORMWATER MANAGEMENT & GRADING PLAN

CPV TOWANTIC ENERGY CENTER

OXFORD CONNECTICUT



WOODBURY CONNECTICUT



DRAWN: BB APPROVED: CJ
SCALE: 1" = 60'
DATE: 26 SEP 14
PROJ. NO.: 98132
CADD FILE NAME: 98132
DRAWING NO.: C 310

N/F
TOWANTIC ENERGY, LLC
884,344 SF = 20.302 ACRES
WETLANDS AREA = 21,062 SF

STORMWATER RENOVATION AREA "B"
EXTENDED DETENTION SHALLOW WETLAND
POOL ELEVATION 821.00
BERM ELEVATION 829.9
100 YEAR ELEVATION 824.86

WETLAND 4 IMPACT
AREA = 178 SF

WETLAND 1 IMPACT
AREA = 10,322 SF

LOT 9A
269,733 SF = 6.192 ACRES
N/F
WOODRUFF HILL VIEW, LLC
VOL. 365, P. 157

PERMANENT WETLAND IMPACTS	WETLANDS ID	IMPACT AREA (SF)
1	10,322	
4	178	
TOTAL		10,500 (0.24 AC.)

TOWER STR 11165

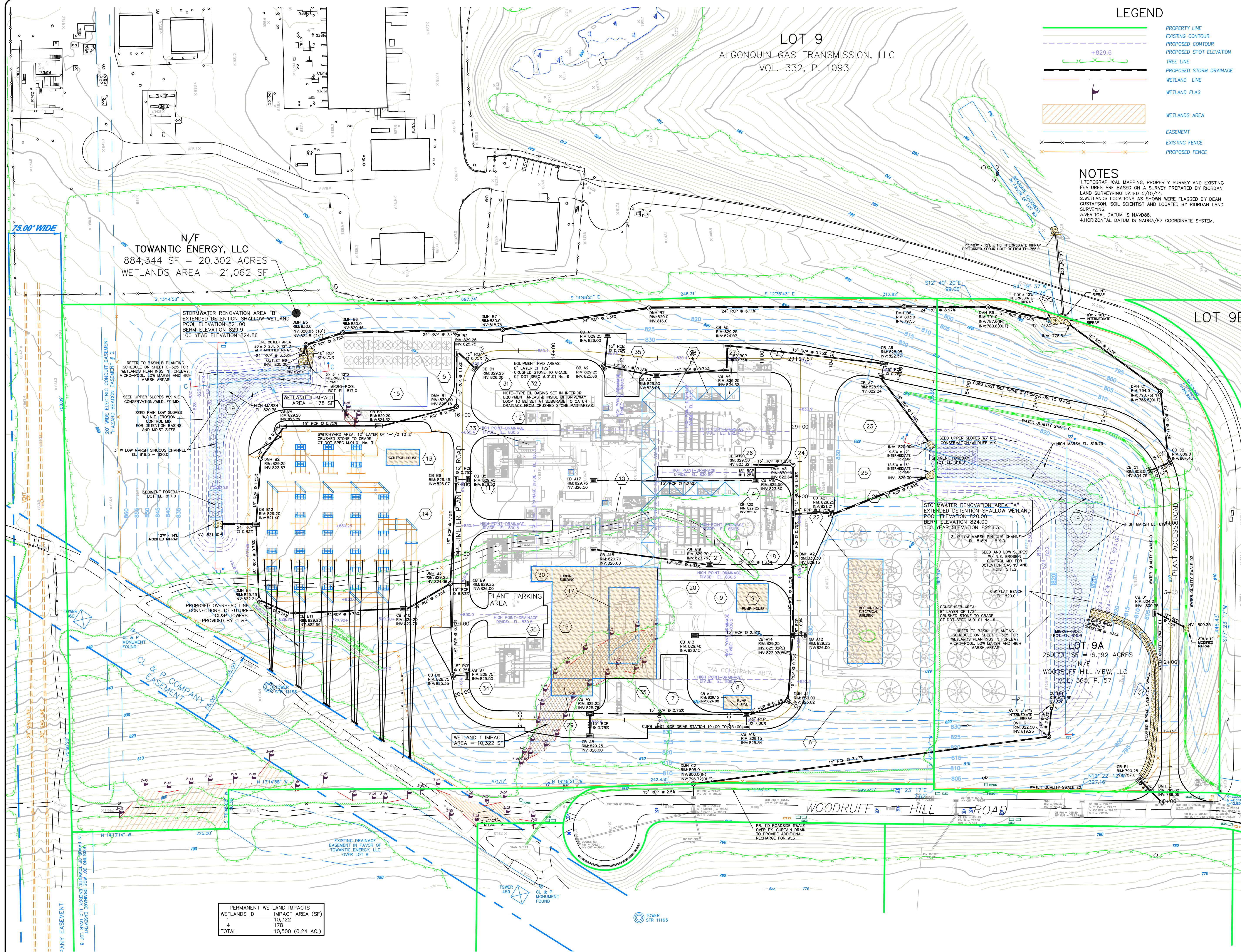

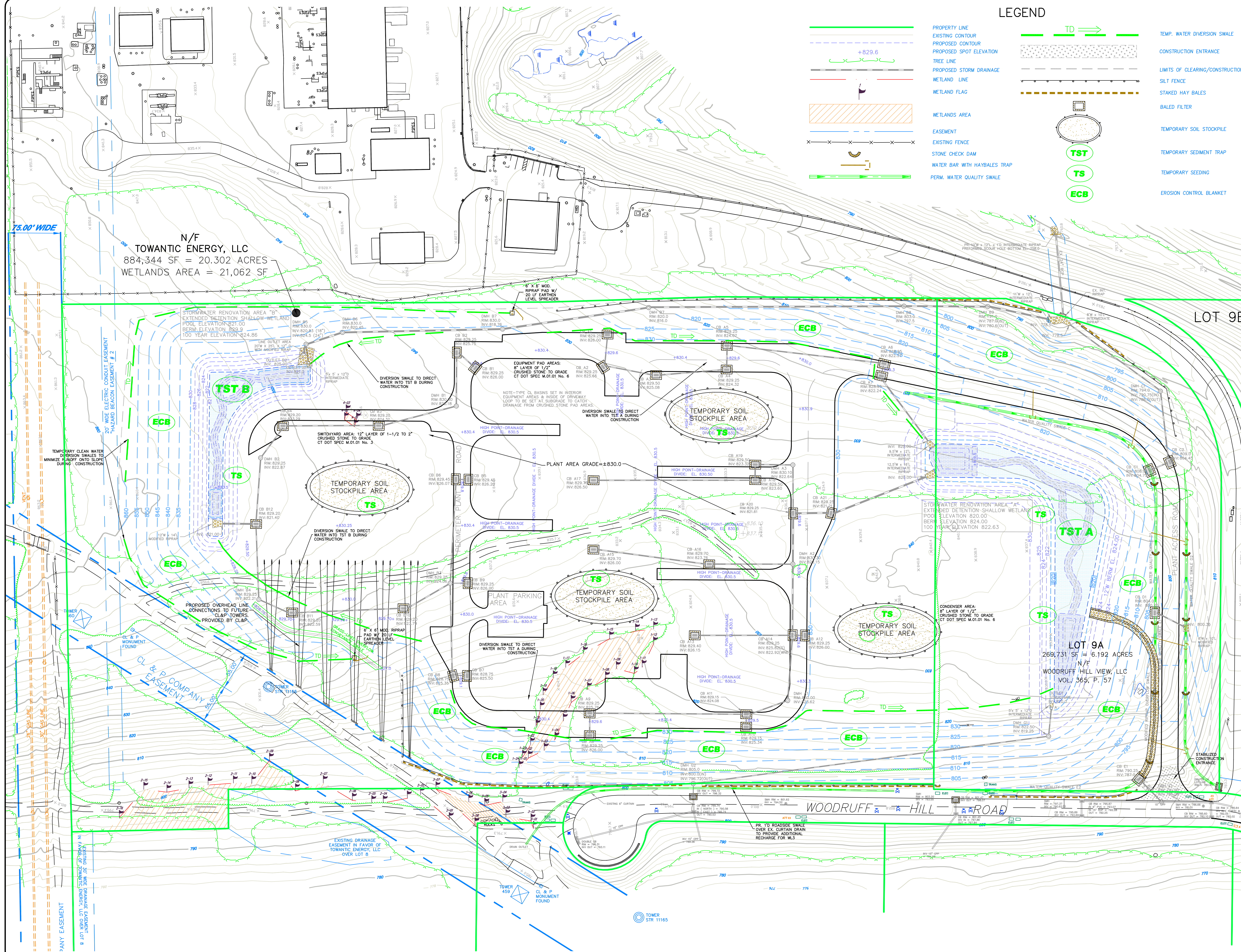

LEGEND

- PROPERTY LINE
- EXISTING CONTOUR
- PROPOSED CONTOUR
- PROPOSED SPOT ELEVATION
- TREE LINE
- PROPOSED STORM DRAINAGE
- WETLAND LINE
- WETLAND FLAG
- WETLANDS AREA
- EASEMENT
- EXISTING FENCE
- STONE CHECK DAM
- WATER BAR WITH HAYBALES TRAP
- PERM. WATER QUALITY SWALE
- TD
- TEMP. WATER DIVERSION SWALE
- CONSTRUCTION ENTRANCE
- LIMITS OF CLEARING/CONSTRUCTION
- SILT FENCE
- STAKED HAY BALES
- BALED FILTER
- TEMPORARY SOIL STOCKPILE
- TEMPORARY SEDIMENT TRAP
- TEMPORARY SEEDING
- EROSION CONTROL BLANKET

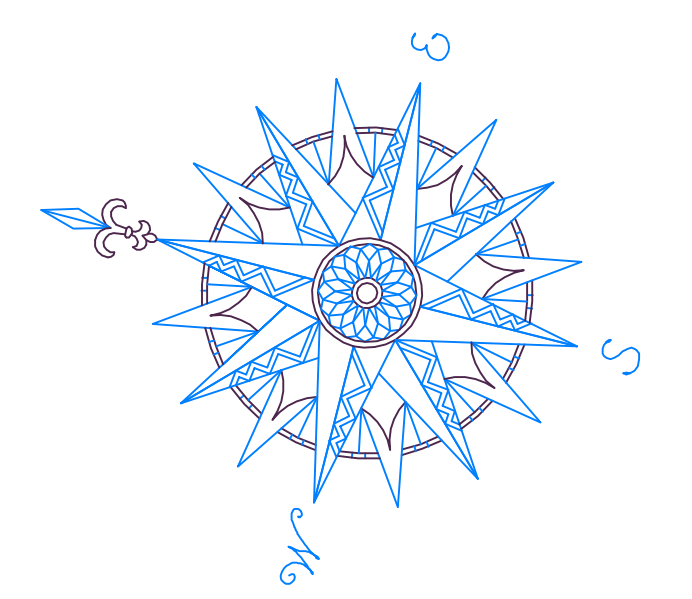

NO.	REVISION	DATE
1	REV. PER SITING COUNCIL REVIEW	13 FEB 15
2	REV. PER CT DEEP REVIEW	24 FEB 15
Previous Editions Obsolete		

LOT 9B

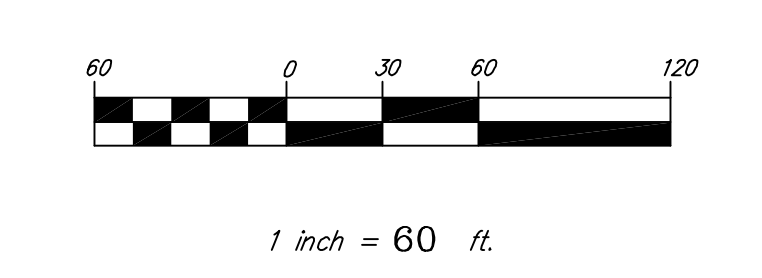

EROSION & SEDIMENT CONTROL PLAN

CPV TOWANTIC ENERGY CENTER

OXFORD CONNECTICUT

Civil 1
 CORNERSTONE PROFESSIONAL PARK, SUITE D-101
 43 SHERMAN HILL ROAD
 WOODBURY CONNECTICUT (203) 266-0778



DRAWN: BB APPROVED: CJ
 SCALE: 1" = 60'
 DATE: 26 SEP 14
 PROJ. NO.: 98132
 CAD FILE NAME: 98132
 DRAWING NO.: **C 315**

N/F
 TOWANTIC ENERGY, LLC
 884,344 SF = 20.302 ACRES
 WETLANDS AREA = 21,062 SF

LOT 9A
 269,731 SF = 6.192 ACRES
 N/F
 WOODRUFF HILL VIEW, LLC
 VOL. 365, P. 157

WOODRUFF HILL ROAD

TOWER STR 11165

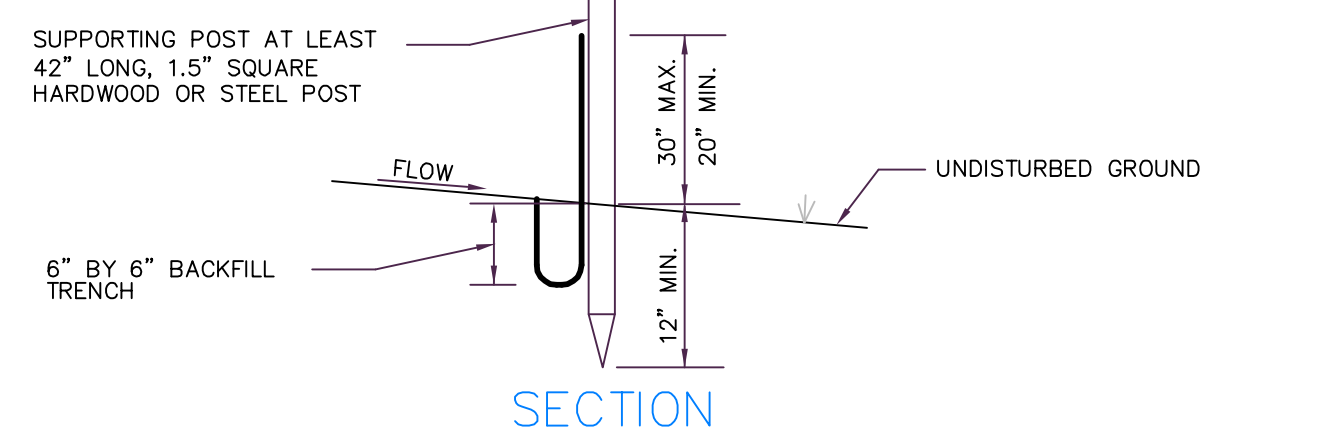
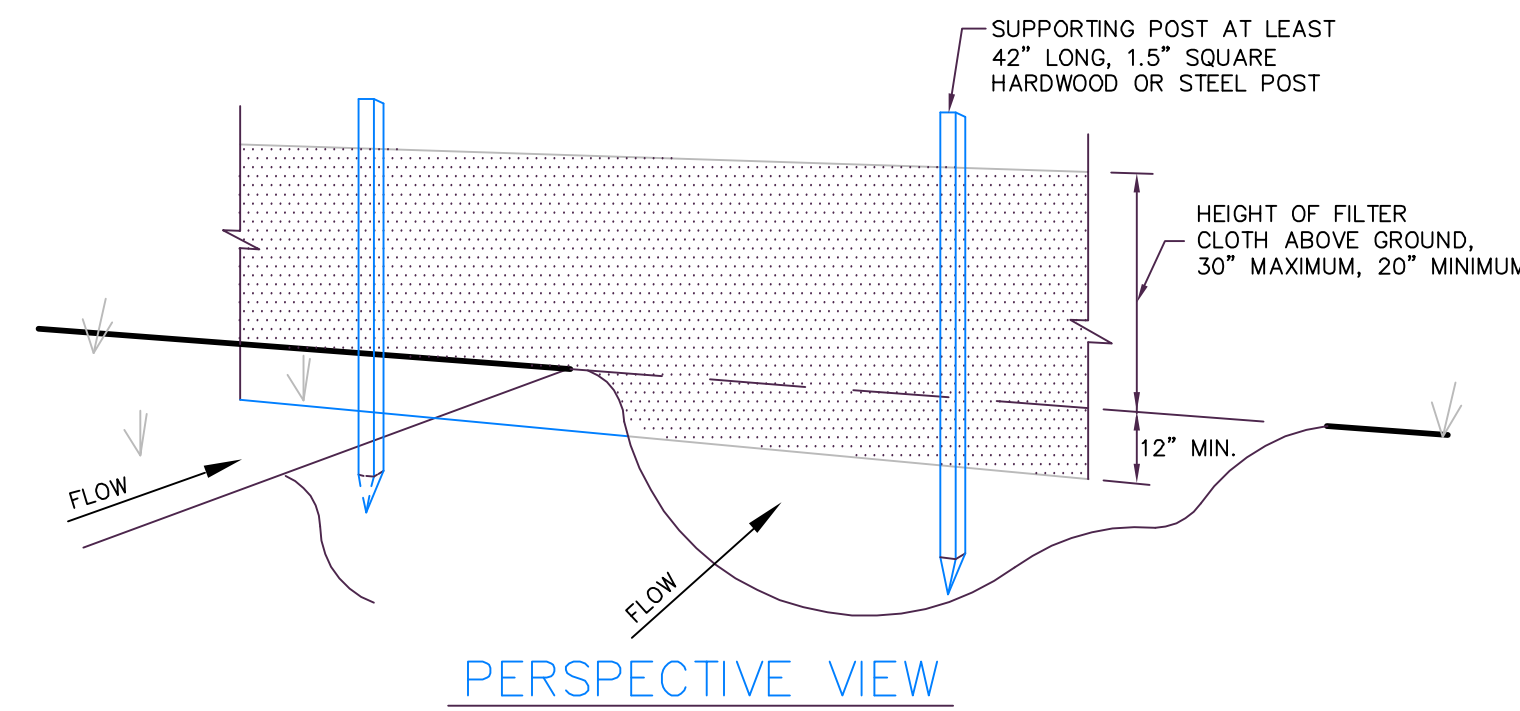

CONSTRUCTION NOTES FOR SILT FENCE

1. EXCAVATE A TRENCH A MINIMUM OF 6 INCHES DEEP AND 6 INCHES WIDE ON THE UP SIDE OF THE FENCE LOCATION.
2. DRIVE SUPPORT POSTS ON THE DOWN SLOPE SIDE OF THE TRENCH TO A DEPTH OF AT LEAST 12 INCHES INTO ORIGINAL GROUND.
3. STAPLE OR SECURE THE GEOTEXTILE TO THE SUPPORT POSTS PER MANUFACTURER'S INSTRUCTIONS SUCH THAT AT LEAST 6 INCHES OF GEOTEXTILE LIES WITHIN THE TRENCH.
4. BACKFILL THE TRENCH WITH TAMPED SOIL OR AGGREGATE OVER THE GEOTEXTILE.

SILT FENCE DETAIL
N.T.S.

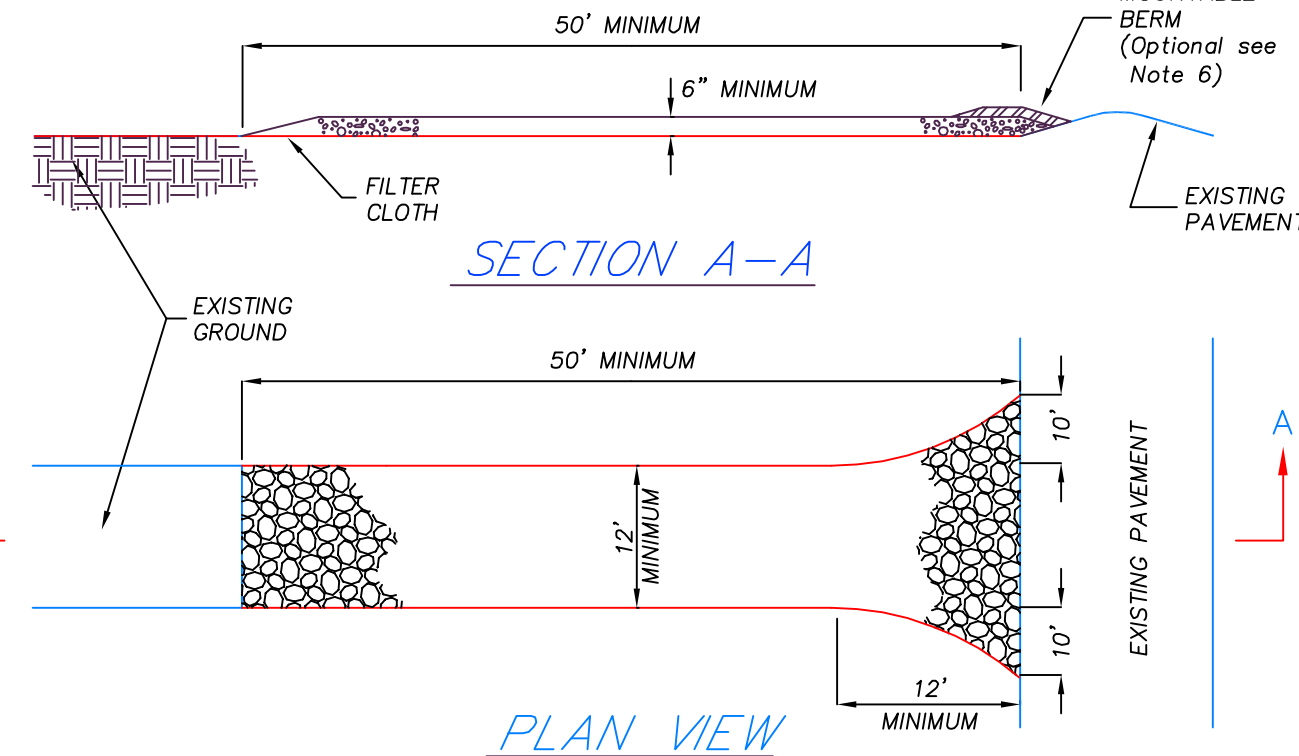
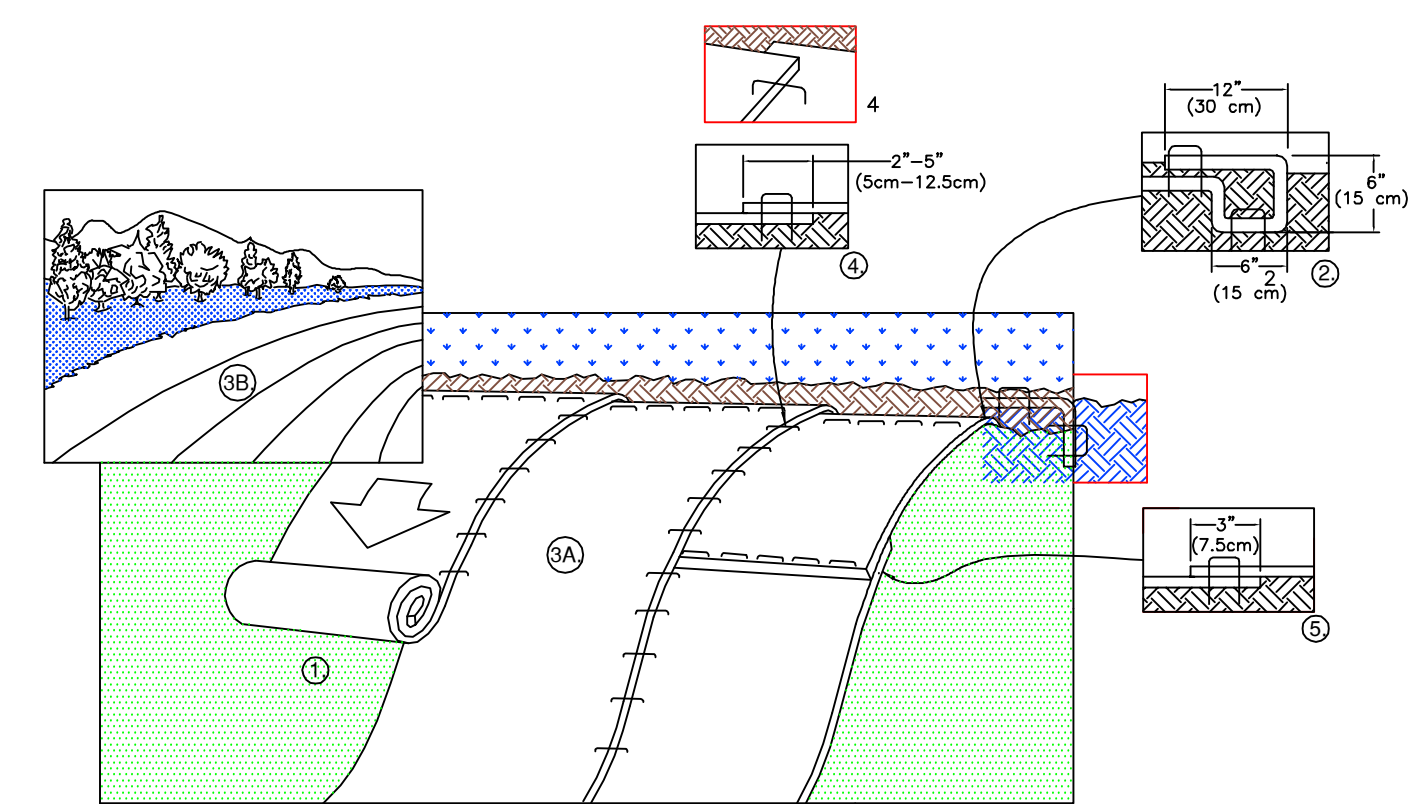

- NOTES:**
1. STONE SIZE - USE 1" - 2" STONE, OR RECLAIMED OR RECYCLED CONCRETE EQUIVALENT.
 2. LENGTH - AS REQUIRED, BUT NOT LESS THAN 50 FEET.
 3. THICKNESS - NOT LESS THAN SIX (6) INCHES.
 4. WIDTH - 12 FOOT MINIMUM, BUT NOT LESS THAN THE FULL WIDTH AT POINTS WHERE INGRESS OR EGRESS OCCURS. 24 FOOT MINIMUM IF SINGLE ENTRANCE TO SITE.
 5. FILTER CLOTH - TO BE PLACED OVER THE ENTIRE AREA PRIOR TO PLACING OF STONE.
 6. SURFACE WATER - ALL SURFACE WATER FLOWING OR DIVERTED TOWARD CONSTRUCTION ENTRANCES SHALL BE PIPED ACROSS THE ENTRANCE. IF PIPING IS IMPRACTICAL, A MOUNTABLE BERM WITH 5:1 SLOPES WILL BE PERMITTED.
 7. MAINTENANCE - THE ENTRANCE SHALL BE MAINTAINED IN A CONDITION WHICH WILL PREVENT TRACKING OF SEDIMENT ONTO PUBLIC RIGHTS-OF-WAY. THIS MAY REQUIRE PERIODIC TOP DRESSING WITH ADDITIONAL STONE AS CONDITIONS DEMAND AND REPAIR AND/OR CLEANOUT OF ANY MEASURE USED TO TRAP SEDIMENT. ALL SEDIMENT SPILLED, DRIPPED, WASHED OR TRACKED ONTO PUBLIC RIGHTS-OF-WAY MUST BE REMOVED IMMEDIATELY.
 8. WASHING - WHEELS SHALL BE CLEANED TO REMOVE SEDIMENT PRIOR TO ENTRANCE ONTO PUBLIC RIGHTS-OF-WAY. WHEN WASHING IS REQUIRED, IT SHALL BE DONE ON AN AREA STABILIZED WITH STONE AND WHICH DRAINS INTO AN APPROVED SEDIMENT TRAPPING DEVICE.
 9. PERIODIC INSPECTION AND NEEDED MAINTENANCE SHALL BE PROVIDED AFTER EACH RAIN.

STABILIZED CONSTRUCTION ENTRANCE
N.T.S.

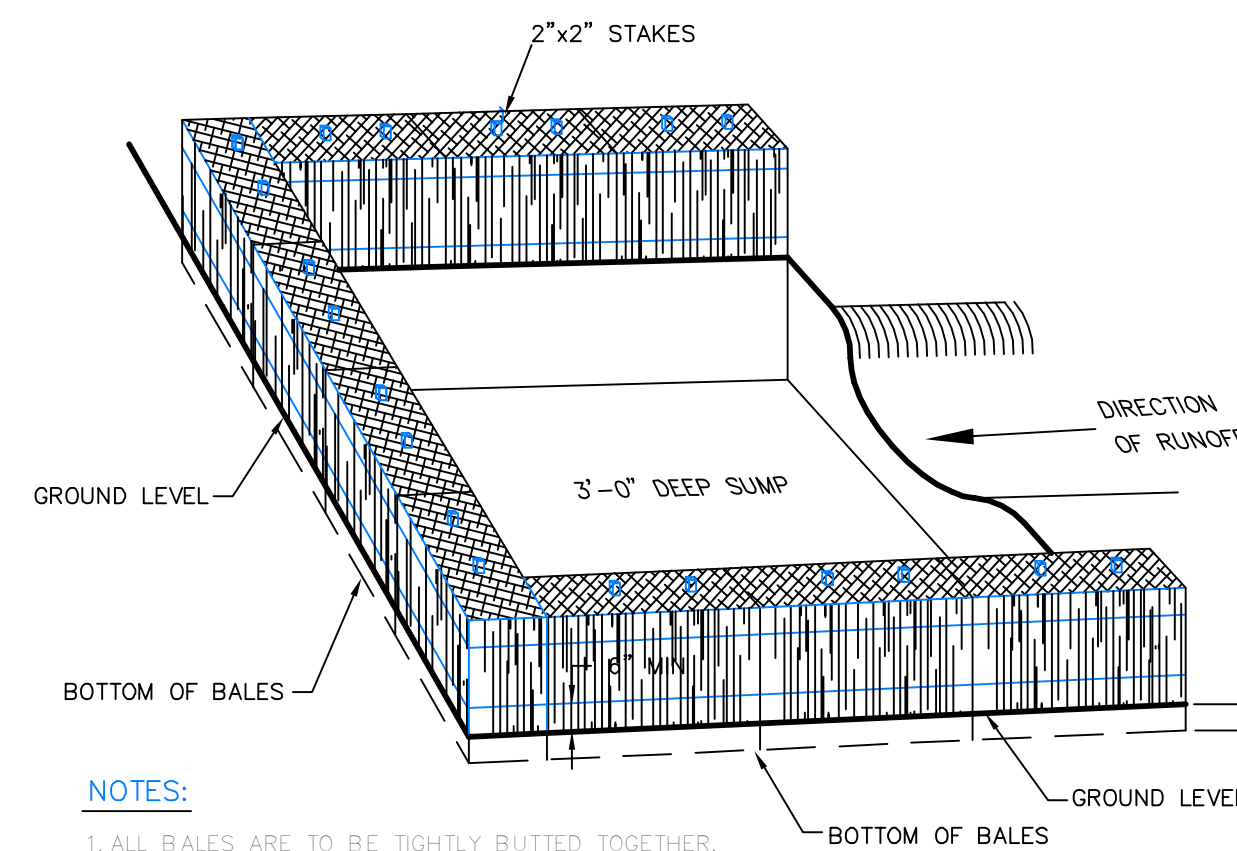

WATER BAR - TEMPORARY DIVERSION DITCH WITH HAYBALE TRAP
N.T.S.

- NOTES:**
1. ALL BALES ARE TO BE TIGHTLY BUTTED TOGETHER.
 2. BALES SHALL BE EITHER STRAW OR HAY.
 3. PROVIDE FREQUENT INSPECTION AND MAINTENANCE. REMOVE ACCUMULATED SEDIMENT AND REPLACE CLOGGED BALES TO RESTORE EFFECTIVENESS OF INSTALLATION.

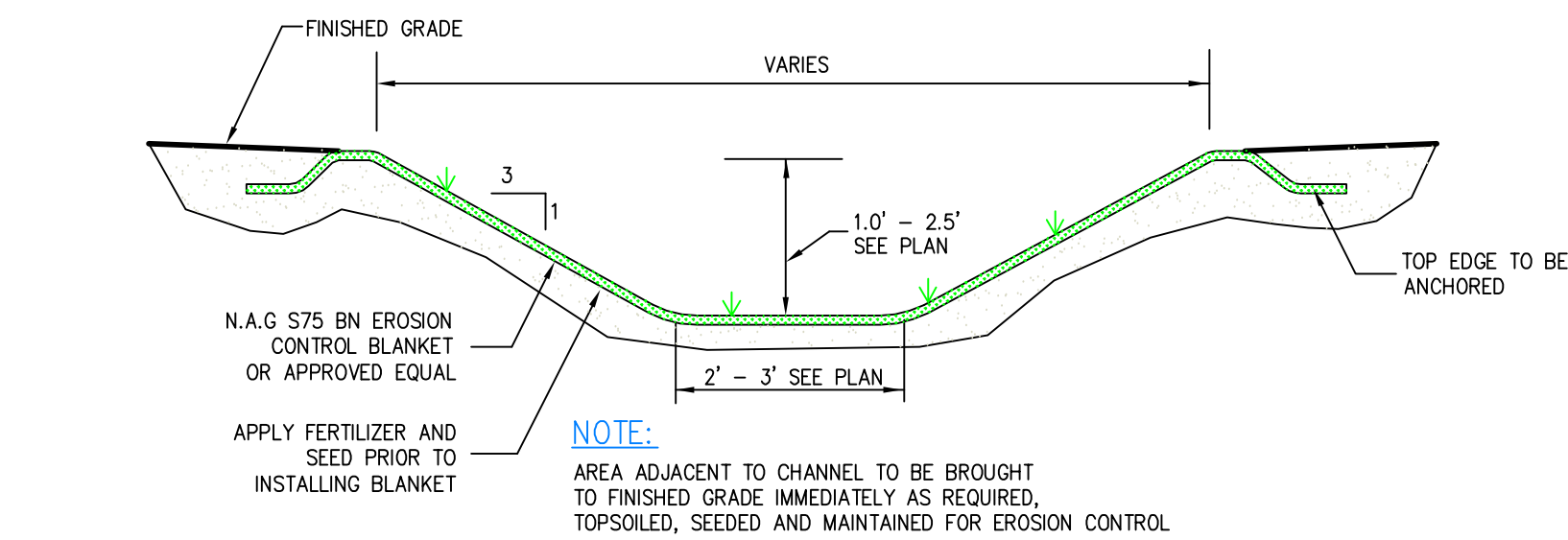

WATER QUALITY & GRASS LINED CONVEYANCE SWALES
N.T.S.

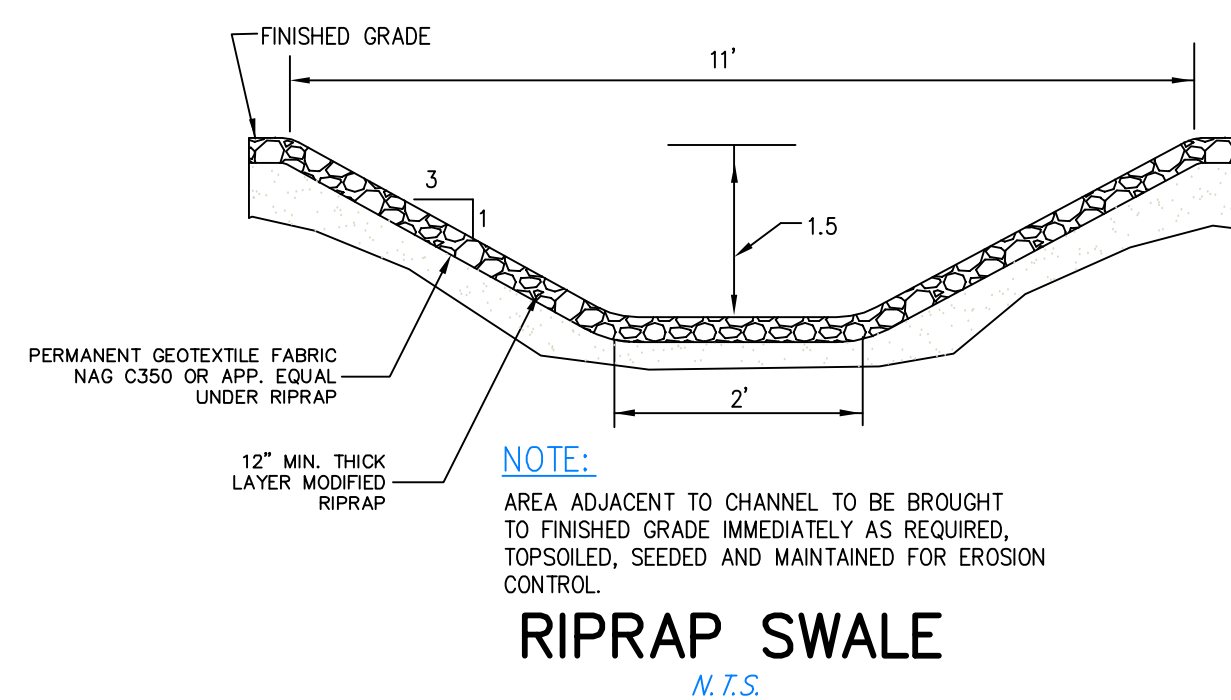

RIPRAP SWALE
N.T.S.

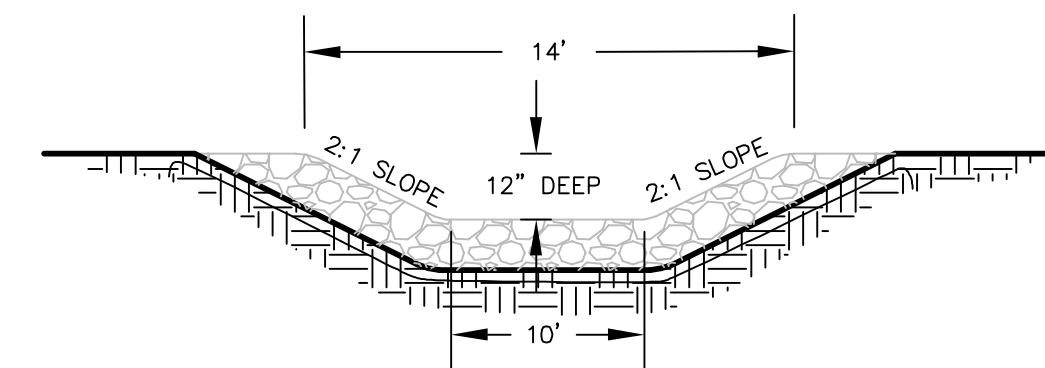
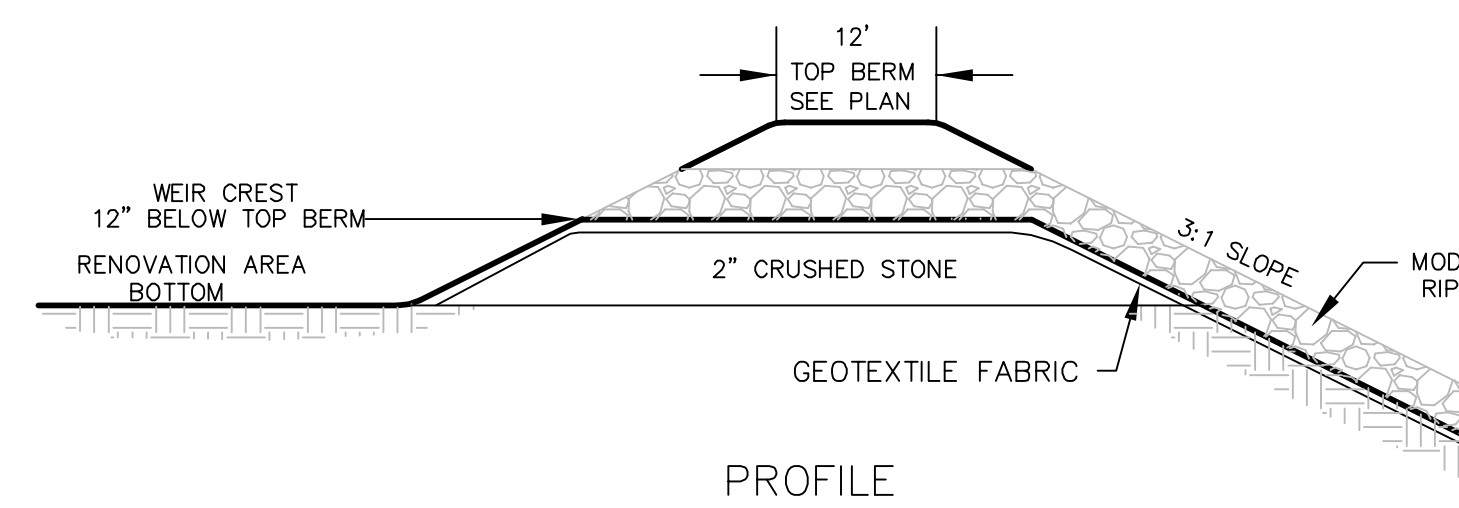
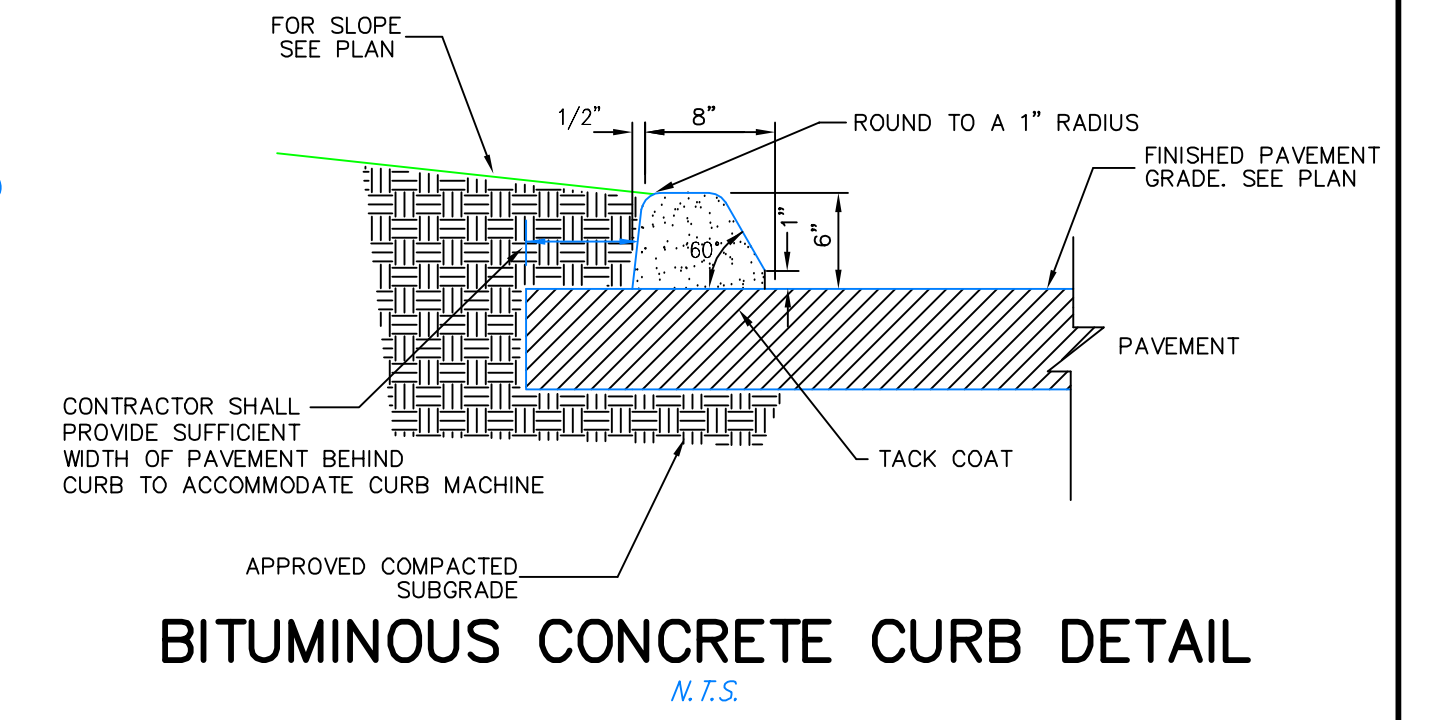
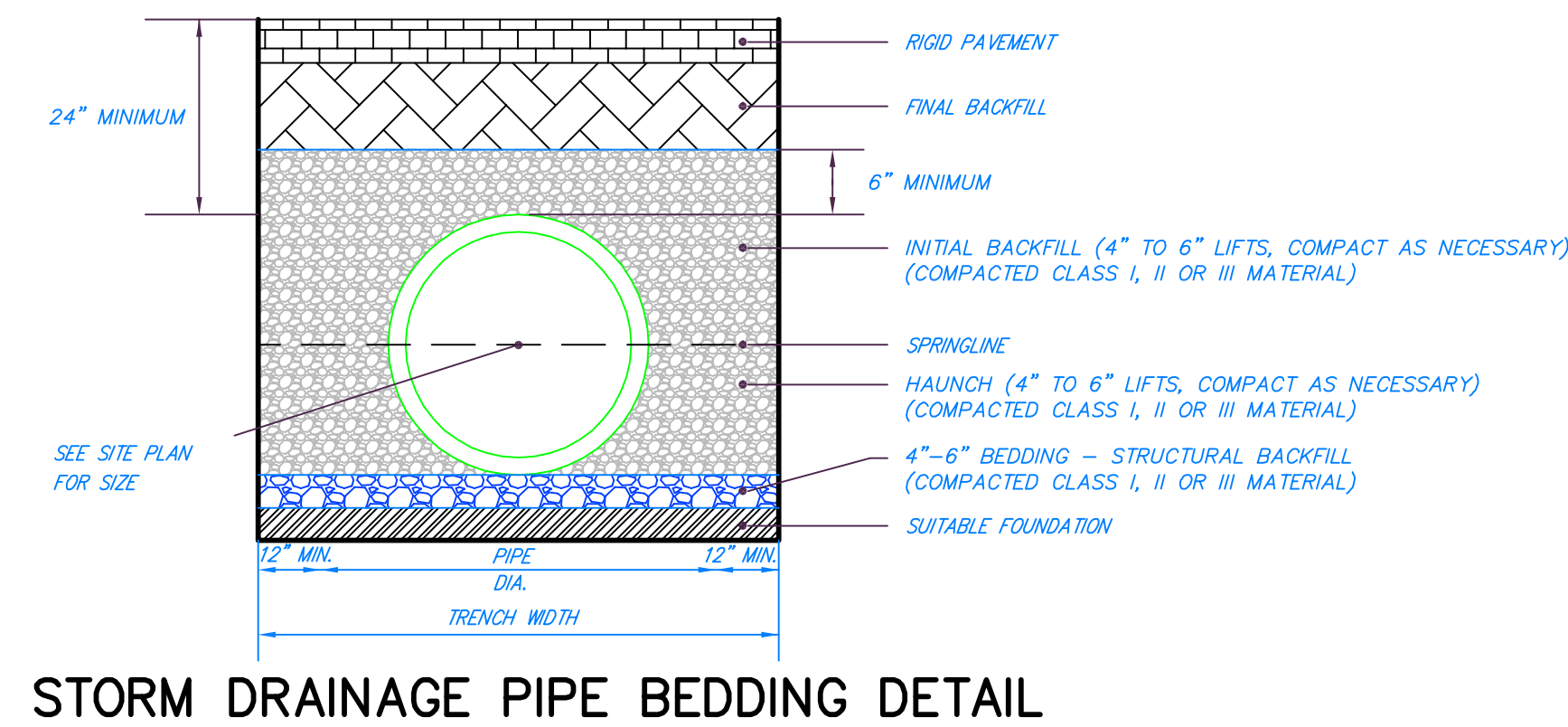

EMERGENCY SPILLWAY SWALE FOR STORMWATER RENOVATION AREA A
N.T.S.

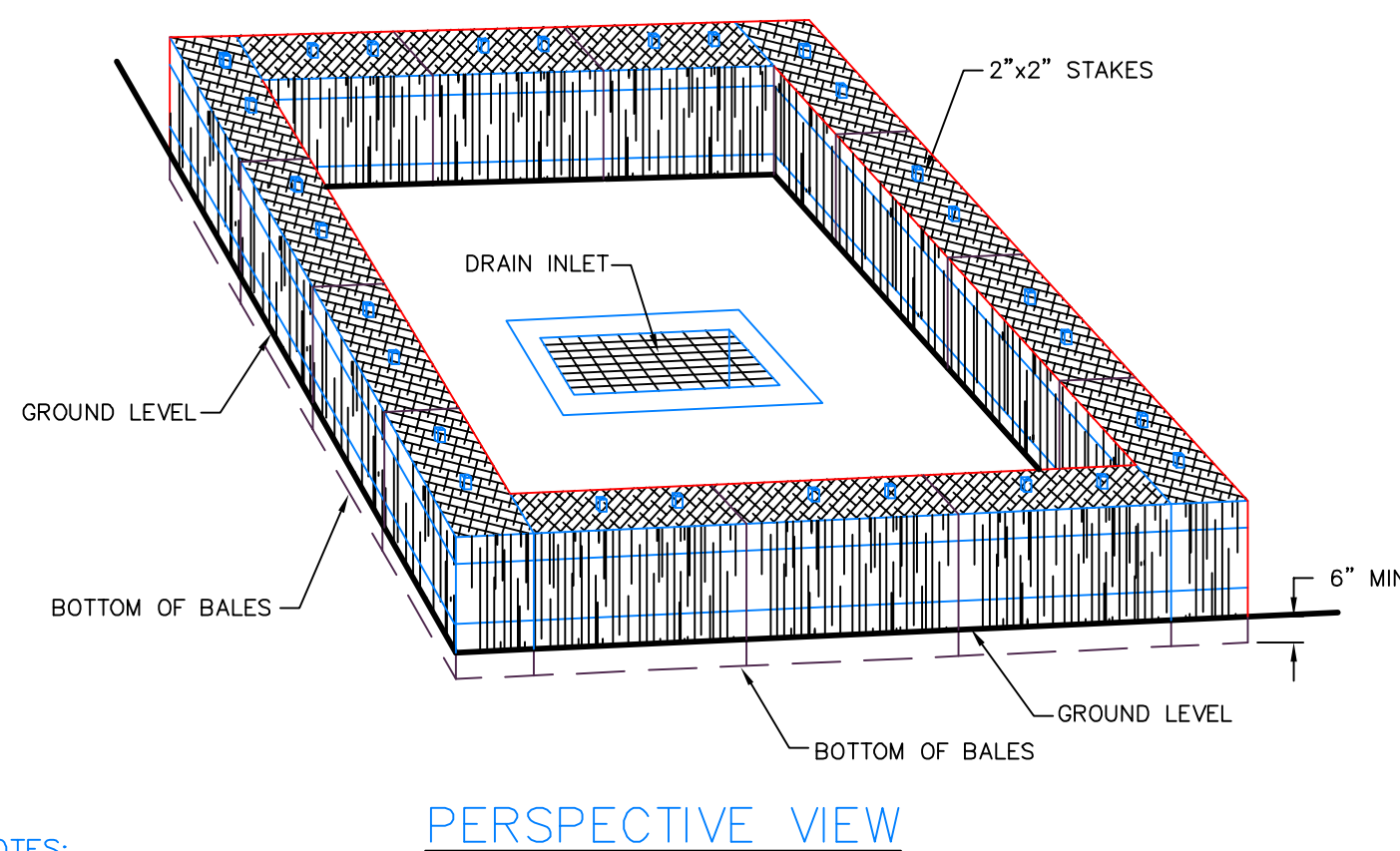
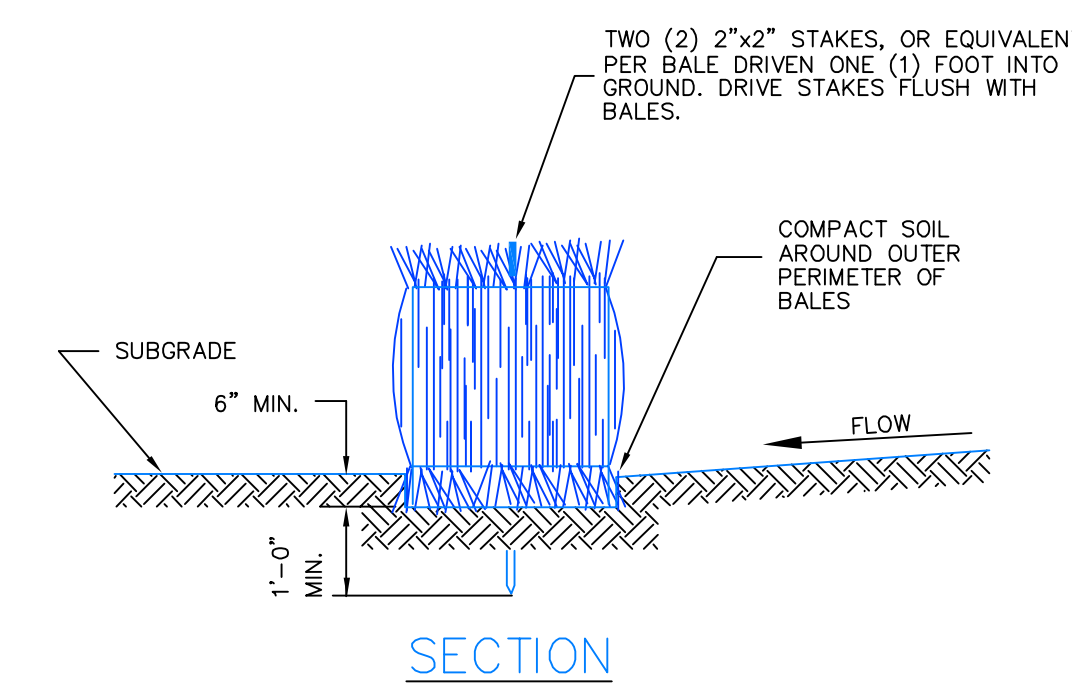

BALED FILTER
N.T.S.

- NOTES:**
1. ALL BALES ARE TO BE TIGHTLY BUTTED TOGETHER.
 2. BALES SHALL BE EITHER STRAW OR HAY.
 3. PROVIDE FREQUENT INSPECTION AND MAINTENANCE. REMOVE ACCUMULATED SEDIMENT AND REPLACE CLOGGED BALES TO RESTORE EFFECTIVENESS OF INSTALLATION.

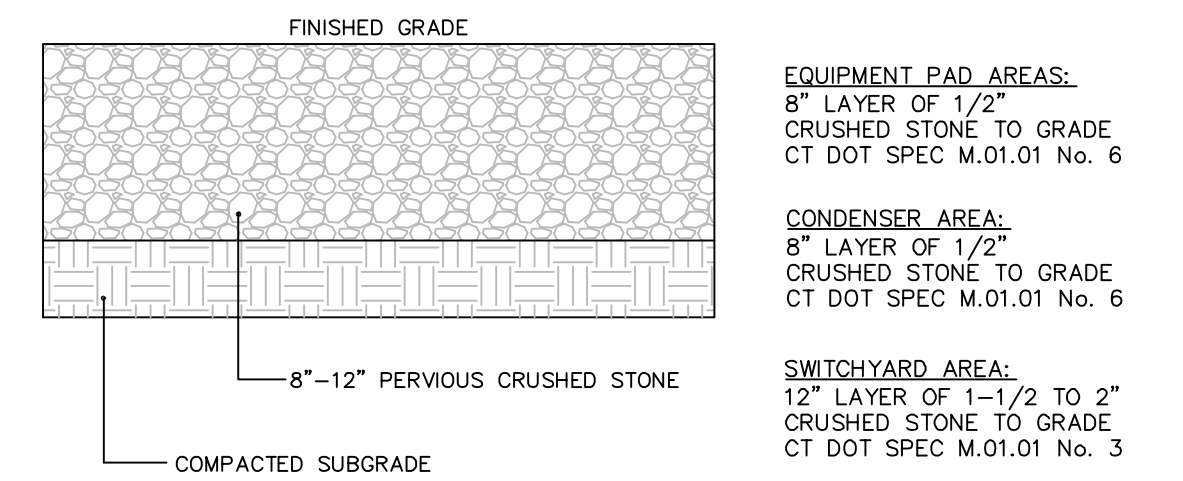

PERVIOUS CRUSHED STONE SURFACE TREATMENT
N.T.S.

NO.	REVISION	DATE
1	REV. PER SITING COUNCIL REVIEW	13 FEB 15

Previous Editions Obsolete

DETAILS

CPV TOWANTIC ENERGY CENTER

OXFORD CONNECTICUT



CORNERSTONE PROFESSIONAL PARK, SUITE D-101
43 SHERMAN HILL ROAD
WOODBURY CONNECTICUT (203) 266-0778

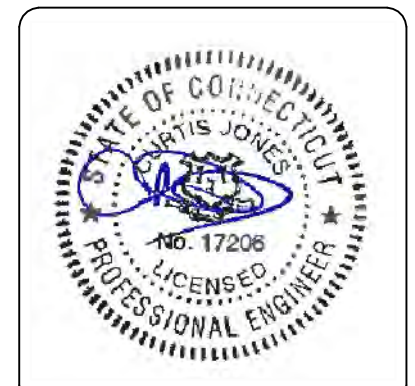

DRAWN: BB APPROVED: CJ
SCALE: N.T.S.
DATE: 26 SEP 14
PROJ. NO.: 98132
CADD FILE NAME: 98132
DRAWING NO.:
C 320

EROSION CONTROL BLANKET
N.T.S.

1. PREPARE SOIL BEFORE INSTALLING BLANKETS, INCLUDING ANY NECESSARY APPLICATION OF LIME, FERTILIZER, AND SEED. NOTE: WHEN USING CELL-O-SEED DO NOT SEED PREPARED AREA. CELL-O-SEED MUST BE INSTALLED WITH PAPER SIDE DOWN.
2. BEGIN AT THE TOP OF THE SLOPE BY ANCHORING THE BLANKET IN A 6" (15cm) DEEP X 6" (15cm) WIDE TRENCH WITH APPROXIMATELY 12" (30cm) OF BLANKET EXTENDED BEYOND THE UP-SLOPE PORTION OF THE TRENCH. ANCHOR THE BLANKET WITH A ROW OF STAPLES/STAKES APPROXIMATELY 12" (30cm) APART IN THE BOTTOM OF THE TRENCH. BACKFILL AND COMPACT THE TRENCH AFTER STAPLING. APPLY SEED TO COMPACTED SOIL AND FOLD REMAINING 12" (30cm) PORTION OF BLANKET BACK OVER SEED AND COMPACTED SOIL. SECURE BLANKET OVER COMPACTED SOIL WITH A ROW OF STAPLES/STAKES SPACED APPROXIMATELY 12" (30cm) APART ACROSS THE WIDTH OF THE BLANKET.
3. ROLL THE BLANKETS (A) DOWN OR (B) HORIZONTALLY ACROSS THE SLOPE. BLANKETS WILL UNROLL WITH APPROPRIATE SIDE AGAINST THE SOIL SURFACE. ALL BLANKETS MUST BE SECURELY FASTENED TO SOIL SURFACE BY PLACING STAPLES/STAKES IN APPROPRIATE LOCATIONS AS SHOWN IN THE STAPLE PATTERN GUIDE. WHEN USING OPTIONAL DOT SYSTEM, STAPLES/STAKES SHOULD BE PLACED THROUGH EACH OF THE COLORED DOTS CORRESPONDING TO THE APPROPRIATE STAPLE PATTERN.
4. THE EDGES OF PARALLEL BLANKETS MUST BE STAPLED WITH APPROXIMATELY 2"-5" (5cm-12.5cm) OVERLAP DEPENDING ON BLANKET TYPE. TO ENSURE PROPER SEAM ALIGNMENT, PLACE THE EDGE OF THE OVERLAPPING BLANKET (BLANKET BEING INSTALLED ON TOP) EVEN WITH THE COLORED SEAM STITCH ON THE PREVIOUSLY INSTALLED BLANKET.
5. CONSECUTIVE BLANKETS SPLICED DOWN THE SLOPE MUST BE PLACED END OVER END (SHINGLE STYLE) WITH AN APPROXIMATE 3" (7.5cm) OVERLAP. STAPLE THROUGH OVERLAPPED AREA, APPROXIMATELY 12" (30cm) APART ACROSS ENTIRE BLANKET WIDTH.

NOTE:
*IN LOOSE SOIL CONDITIONS, THE USE OF STAPLE OR STAKE LENGTHS GREATER THAN 6" (15cm) MAY BE NECESSARY TO PROPERLY SECURE THE BLANKETS.

EROSION CONTROL BLANKETS

S75: Material:
100% straw matrix sewn into a photo-degradable net.
Straw: 5 lbs/sq. yd.
Net: Lightweight degradable (Top side only)

S150: Material:
Straw fiber matrix sewn between two photo-degradable nets.
Straw: 5 lbs/sq. yd.
Net: Lightweight degradable (Both sides)

CRITICAL POINTS
A. OVERLAPS AND SEAMS
B. PROJECTED WATER LINE
C. CHANNEL BOTTOM/SIDE SLOPE VERTICES

NOTE:
* HORIZONTAL STAPLE SPACINGS SHOULD BE ALTERED IF NECESSARY TO ALLOW STAPLES TO SECURE THE CRITICAL POINTS ALONG THE CHANNEL SURFACE.
* IN LOOSE SOIL CONDITIONS, THE USE OF STAPLE OR STAKE LENGTHS IN EXCESS OF 6" (15 cm) MAY BE NECESSARY TO PROPERLY ANCHOR THE BLANKETS.

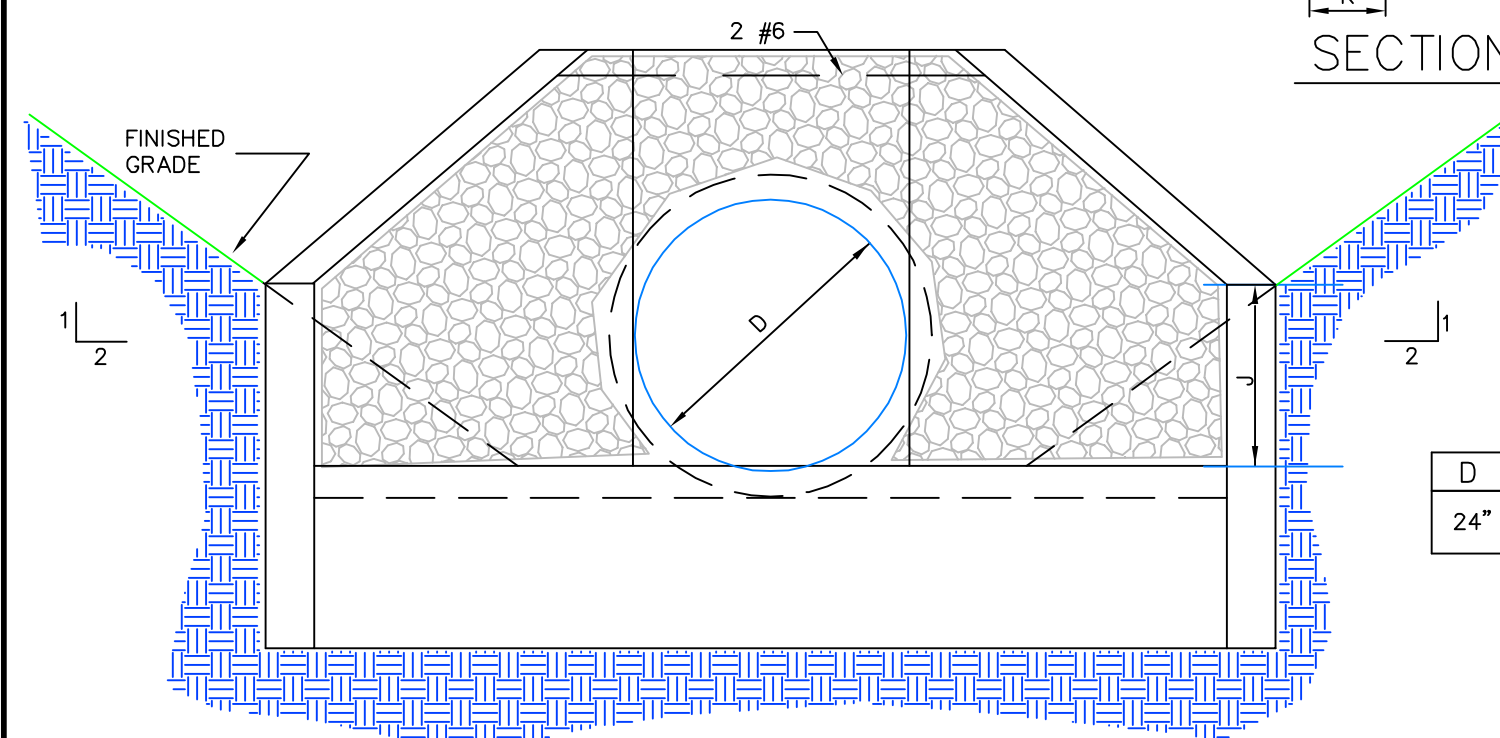
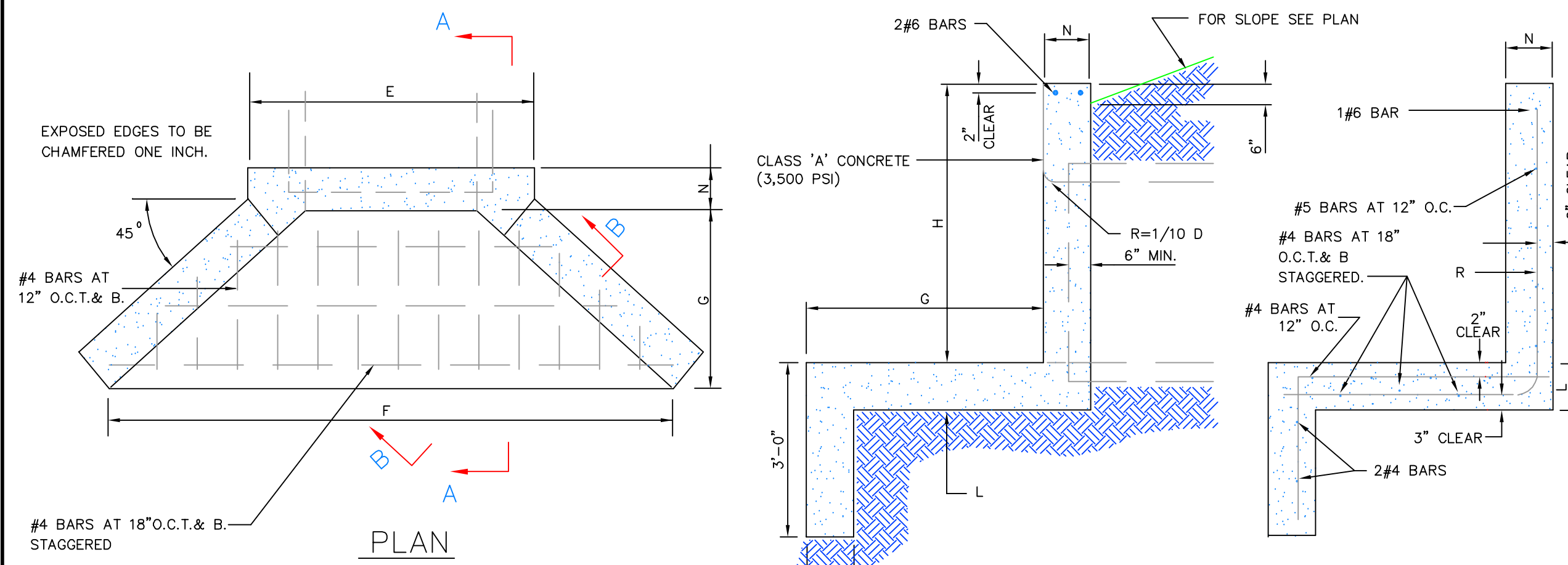

D	E	F	G	H	J	K	L	R	N
24"	3'-8"	8'-0"	3'-0"	3'-6"	1'-6"	8"	8"	#5 @ 12" O.C.	8"

TABLE OF DIMENSIONS

STORMWATER RENOVATION AREA B OUTLET STRUCTURE B2
N.T.S.

SECTION A-A

SECTION B-B

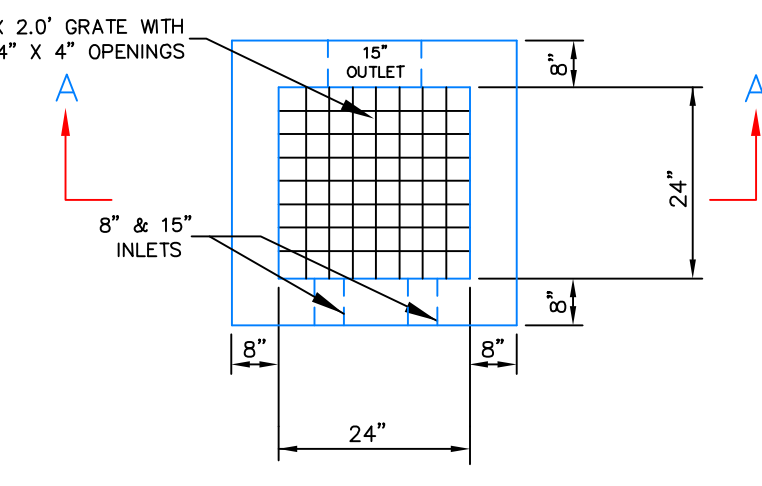
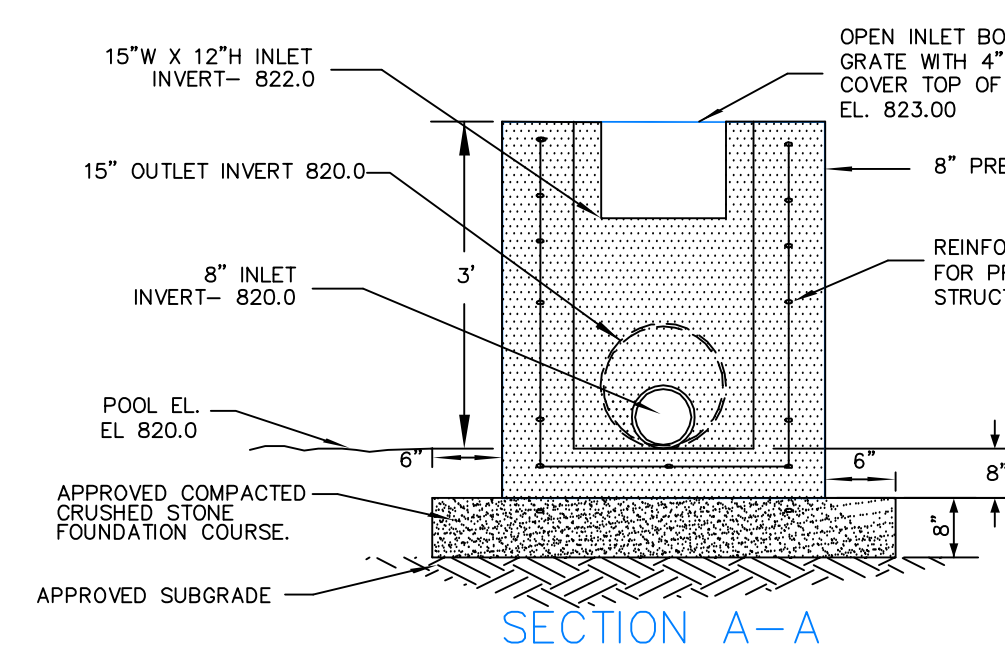

STORMWATER RENOVATION AREA A OUTLET CONTROL STRUCTURE A
N.T.S.

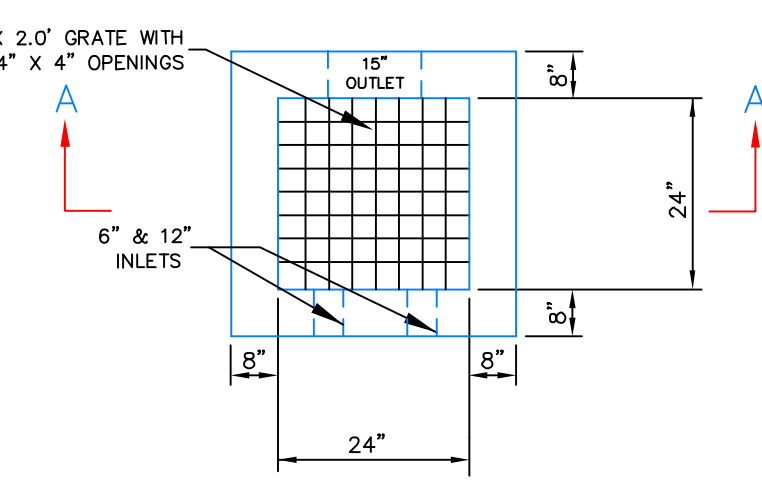
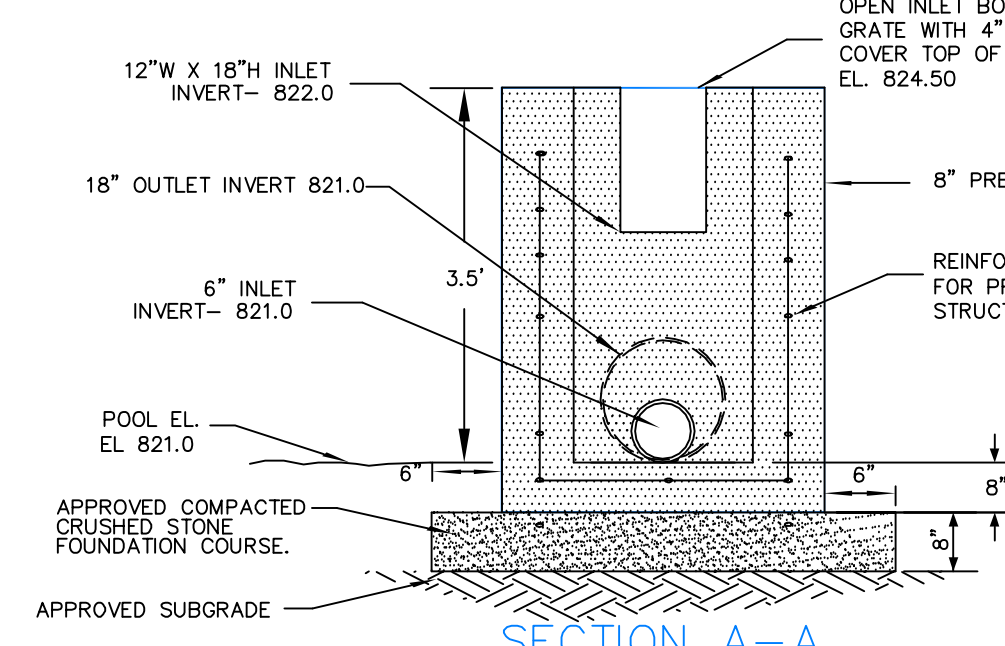

STORMWATER RENOVATION AREA B OUTLET CONTROL STRUCTURE B1
N.T.S.

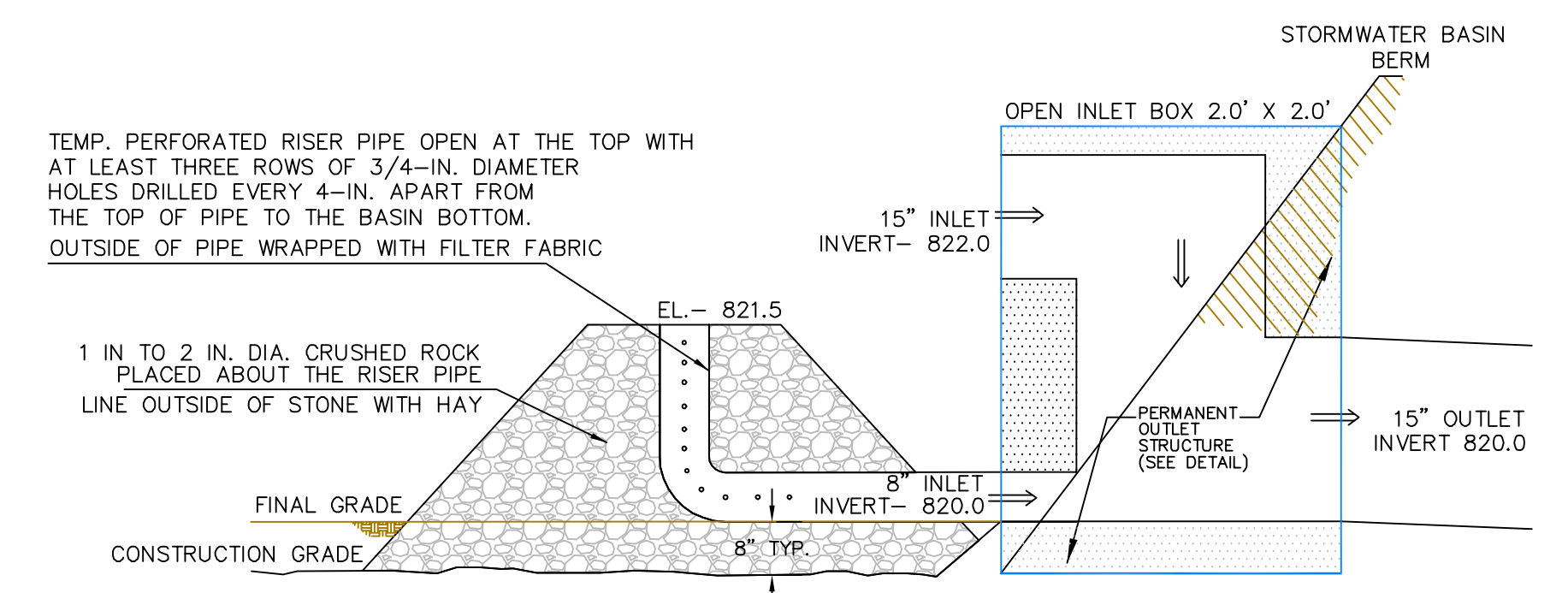

TEMPORARY OUTLET PIPE FOR SEDIMENT CONTAINMENT RENOVATION AREA A
N.T.S.

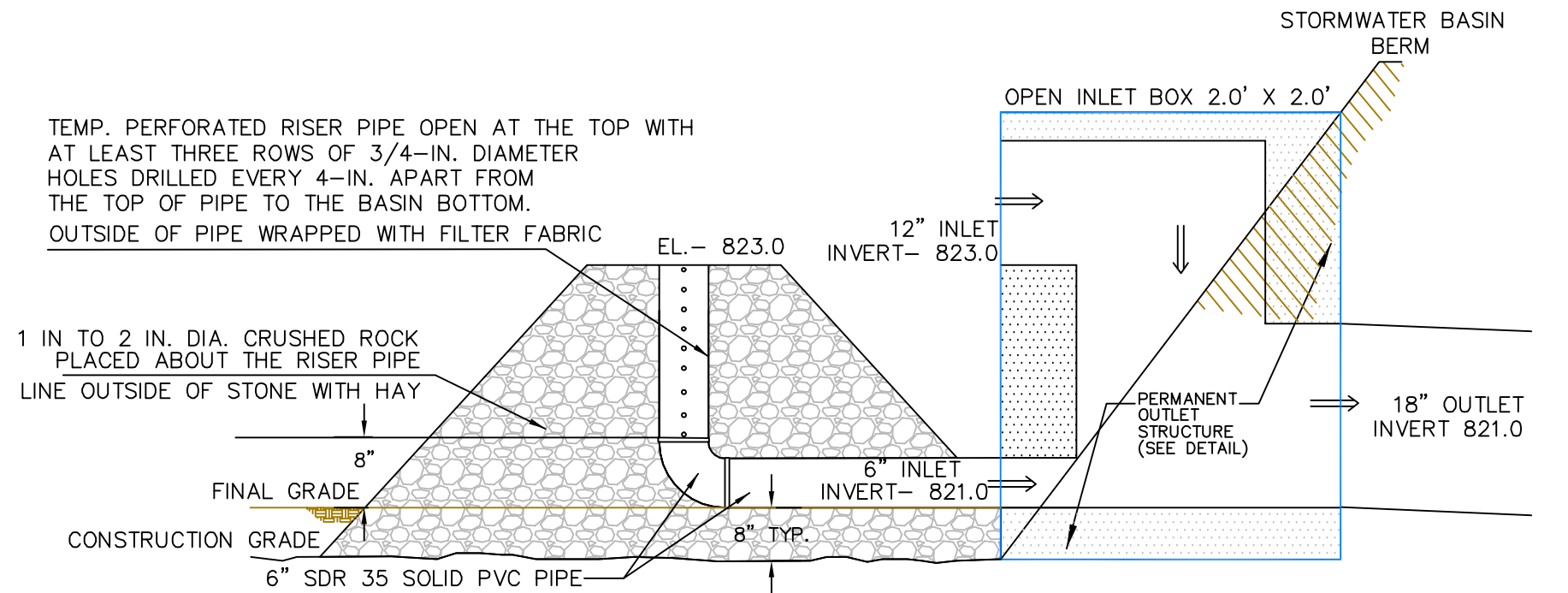

TEMPORARY OUTLET PIPE FOR SEDIMENT CONTAINMENT RENOVATION AREA B
N.T.S.

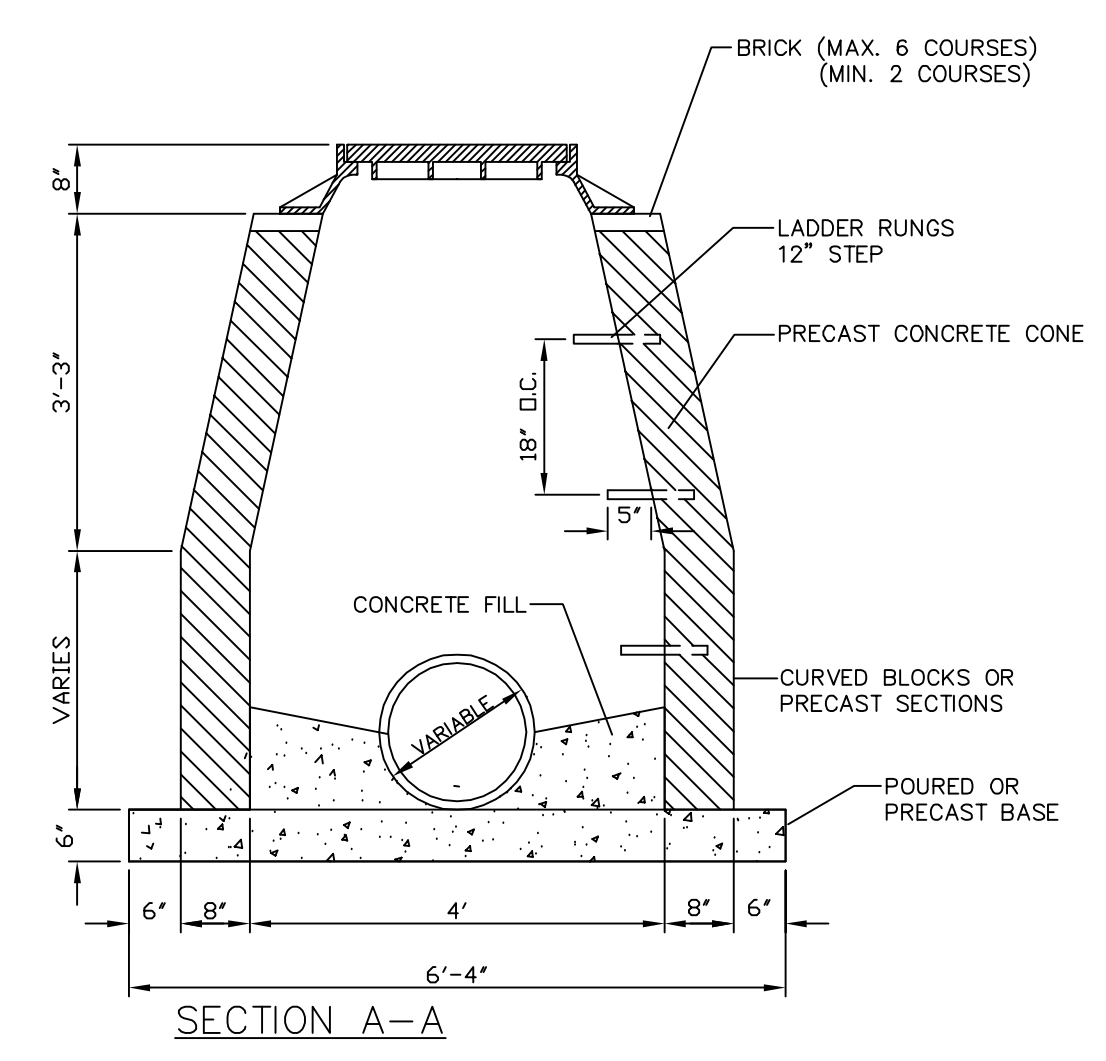
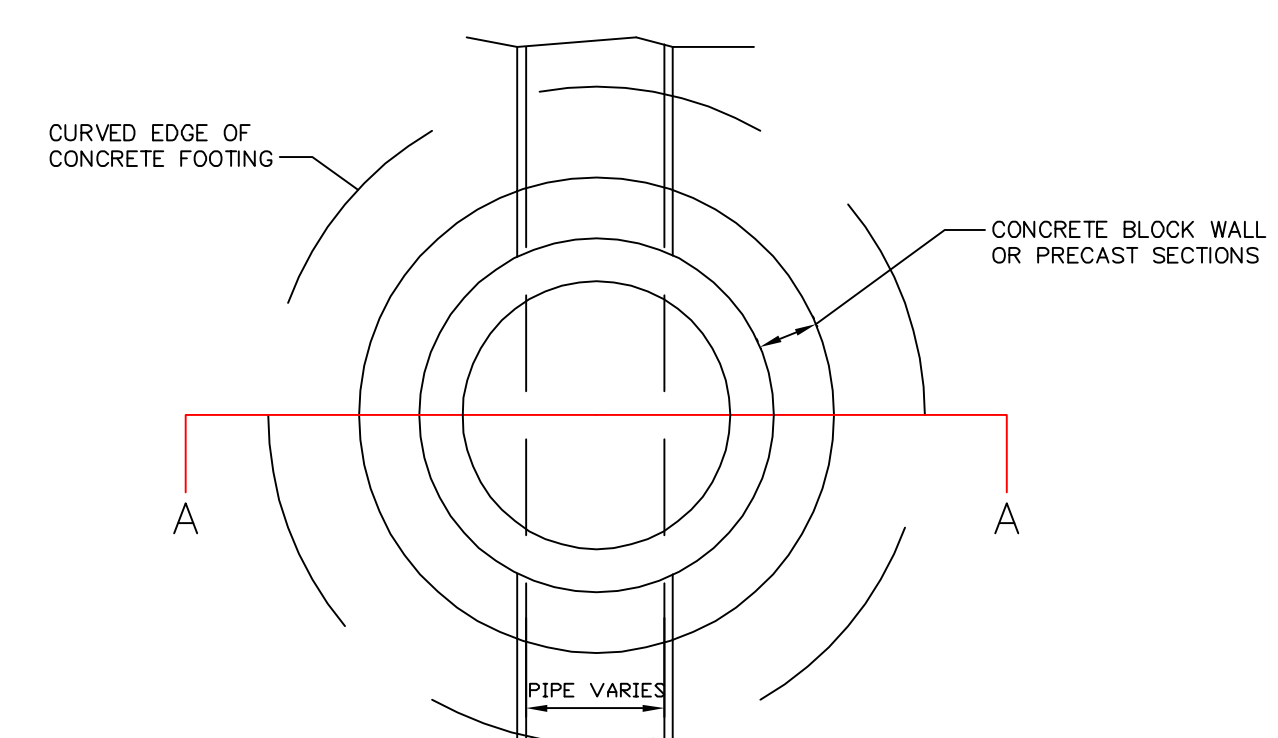

DRAINAGE MANHOLE
without sump

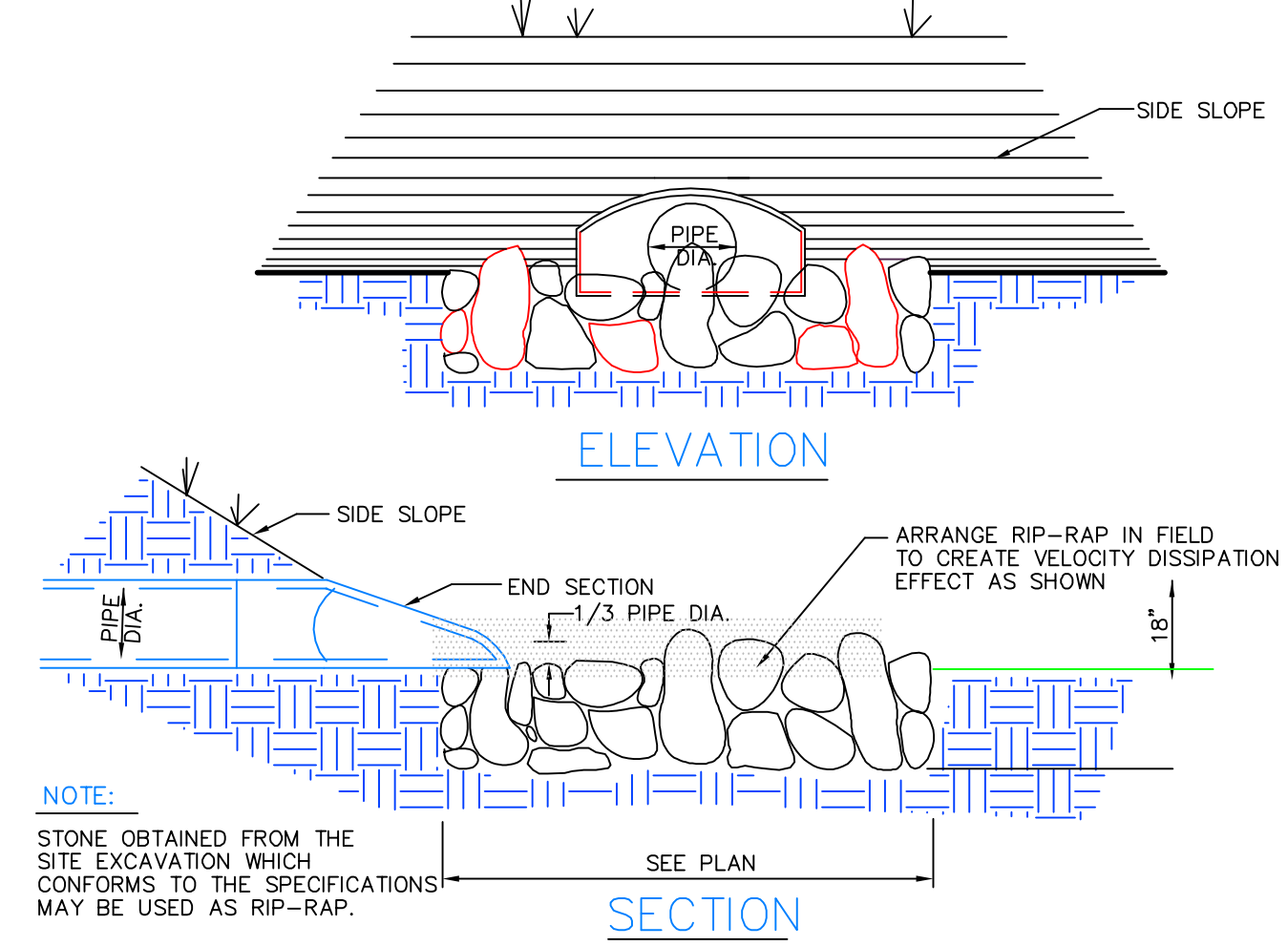
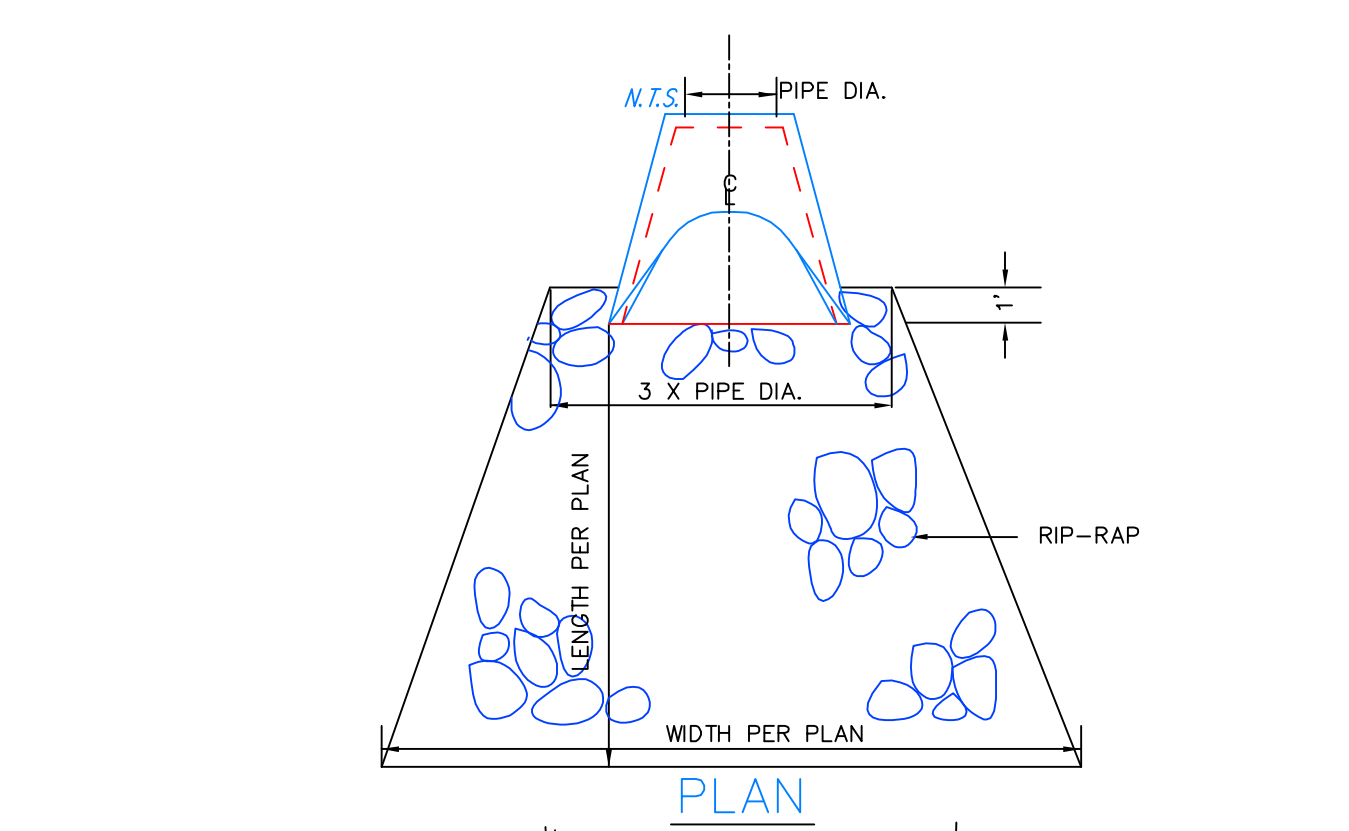

RIP-RAP OUTLET PROTECTION
N.T.S.

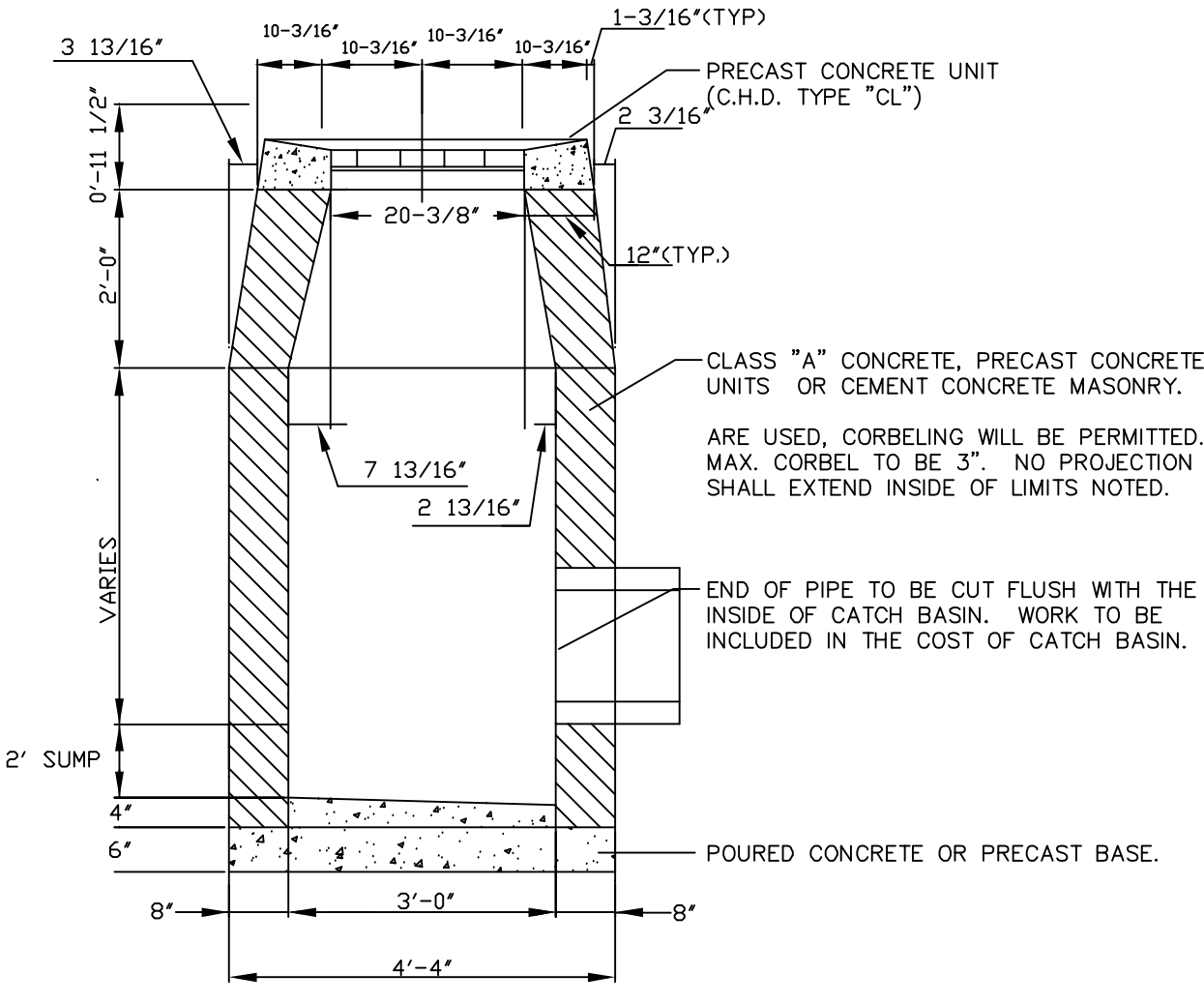
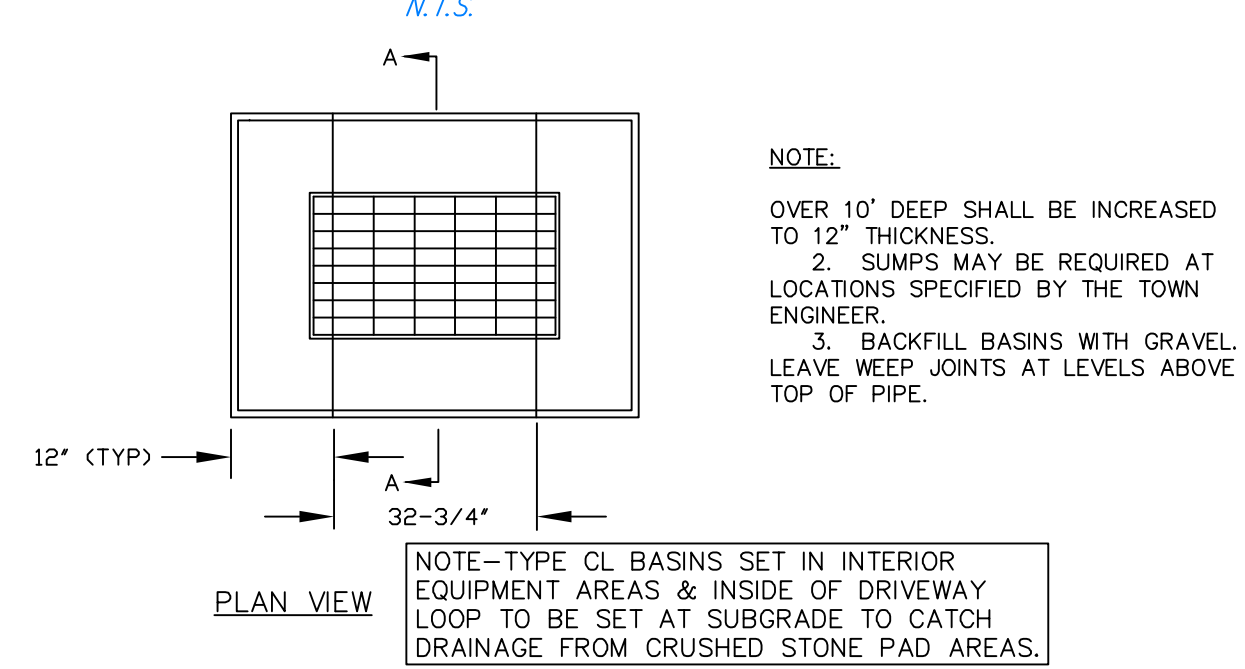

STANDARD TYPE "CL" CATCH BASIN
N.T.S.

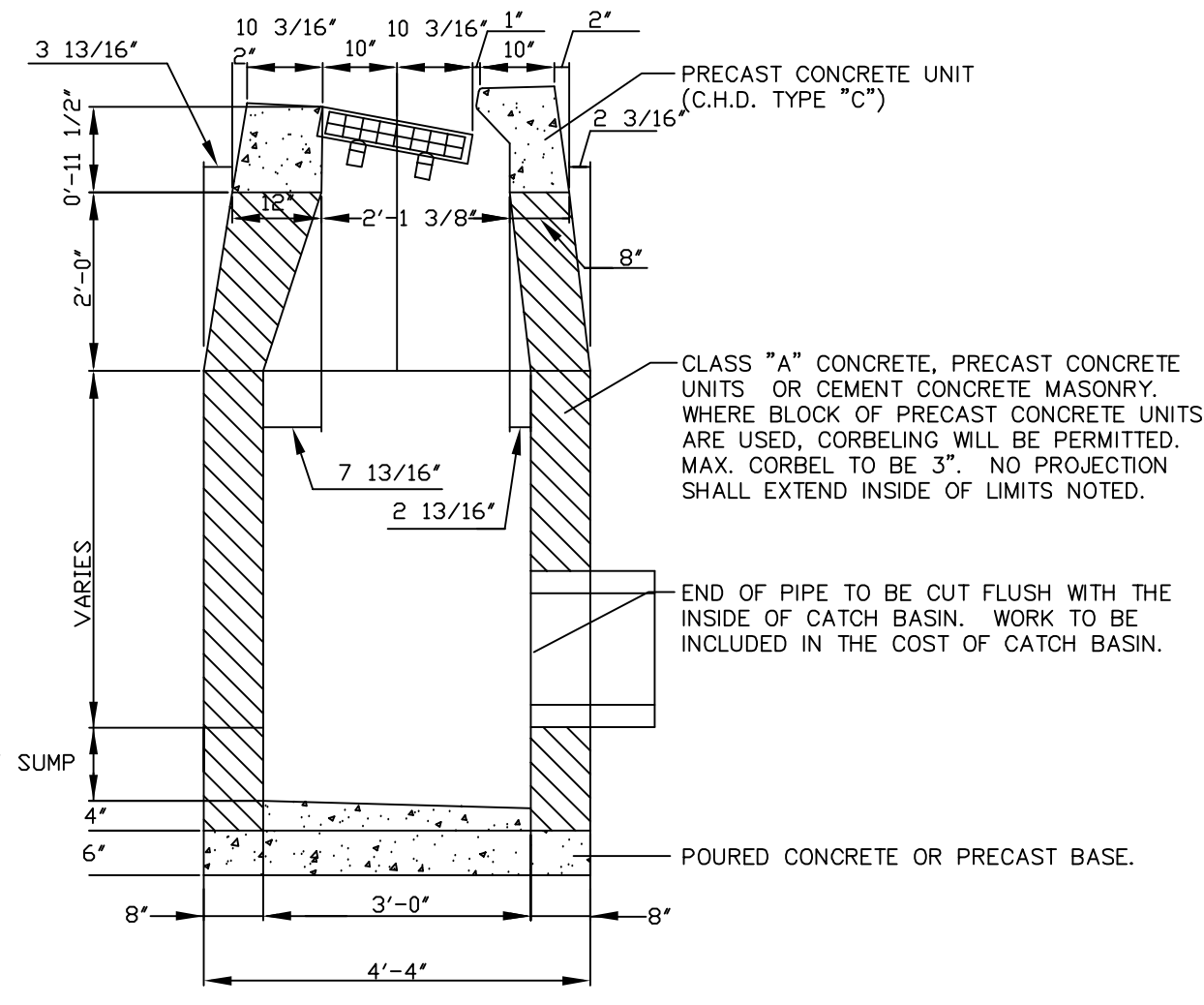
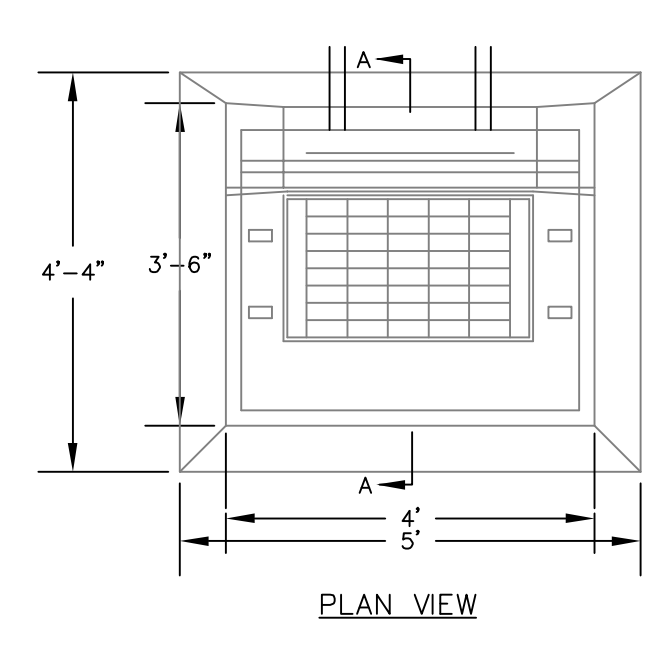

STANDARD TYPE "C" CATCH BASIN
N.T.S.

NO.	REVISION	DATE
1	REV. PER SITING COUNCIL REVIEW	13 FEB 15

Previous Editions Obsolete

STORM DRAINAGE DETAILS

CPV TOWANTIC ENERGY CENTER

WOODBURY CONNECTICUT

CORNERSTONE PROFESSIONAL PARK, SUITE D-101
43 SHERMAN HILL ROAD
(203) 266-0778

CONNECTIONS

NO. 17206
LICENSED PROFESSIONAL ENGINEER

SCALE: N.T.S.
DATE: 26 SEP 14
PROJ. NO.: 98132
CADD FILE NAME: 98132
DRAWING NO.: C 321

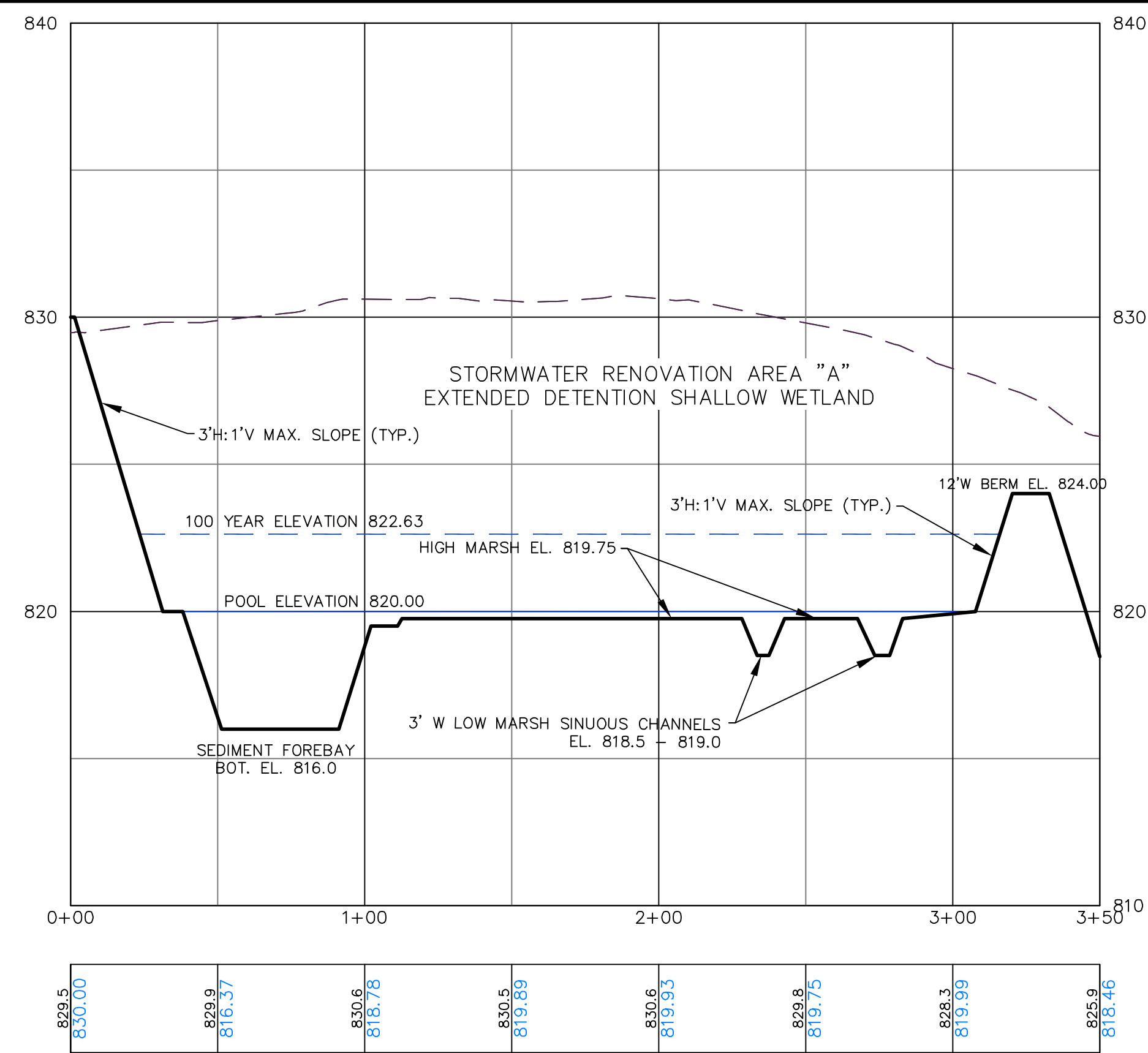

SECTION A-A

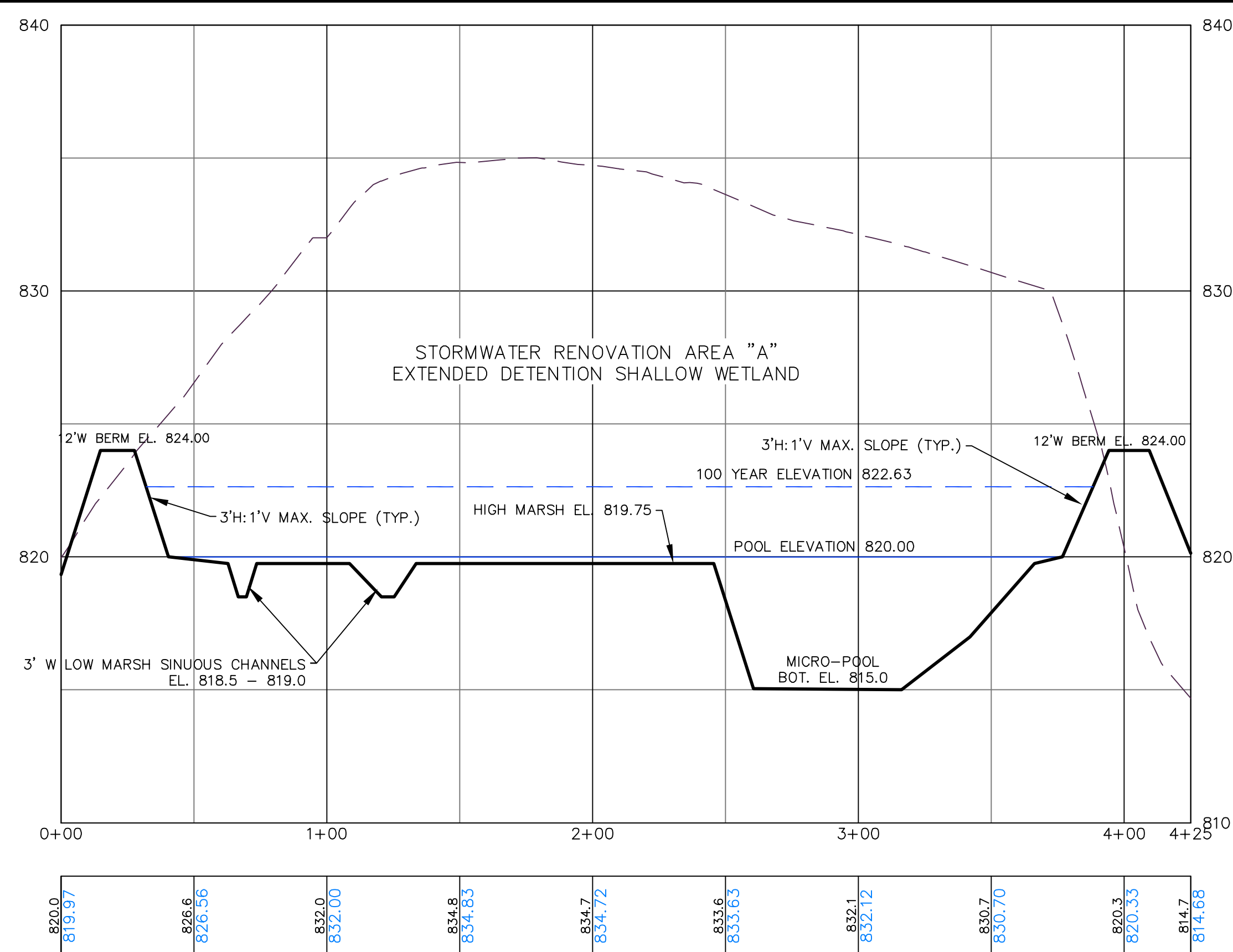

SECTION B-B

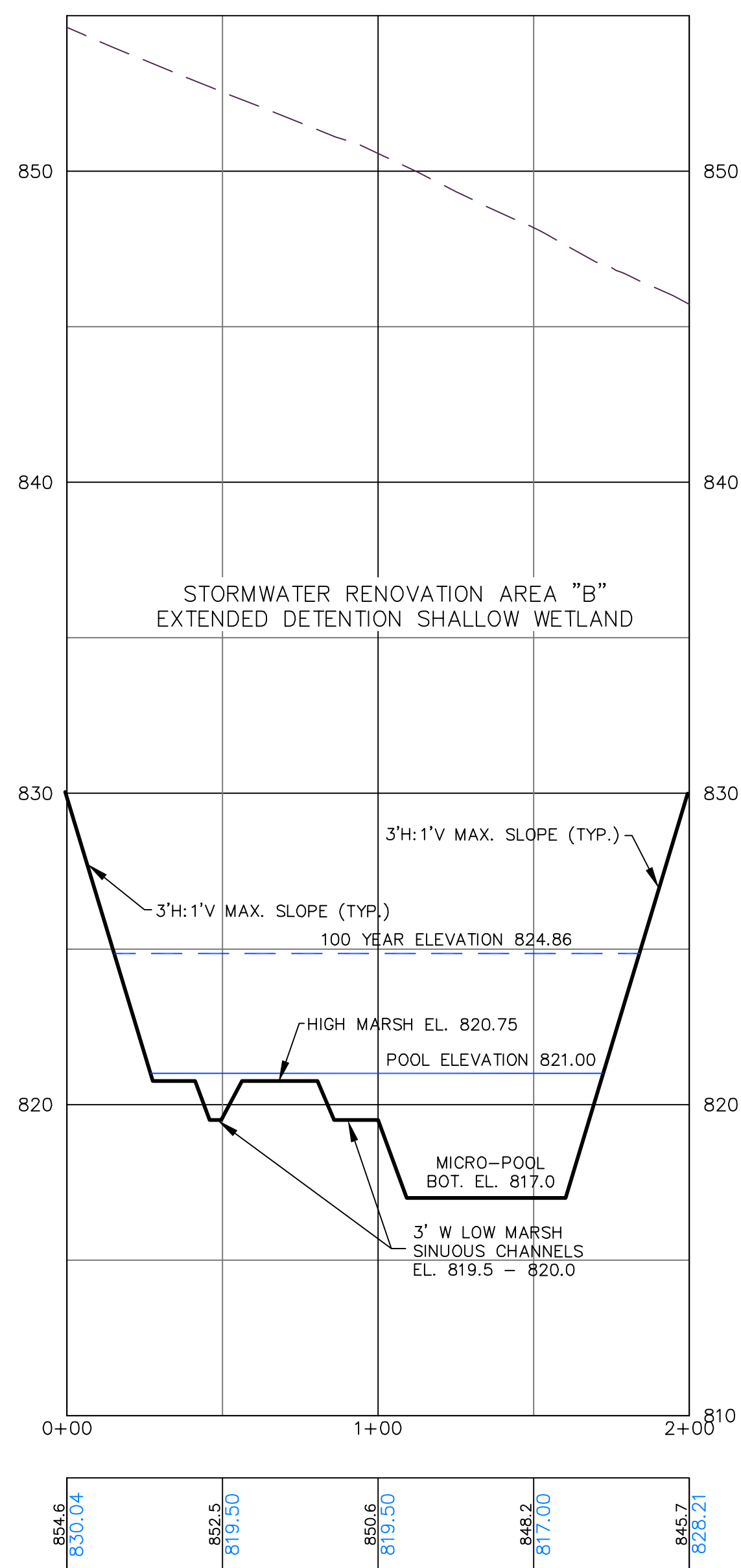

SECTION C-C

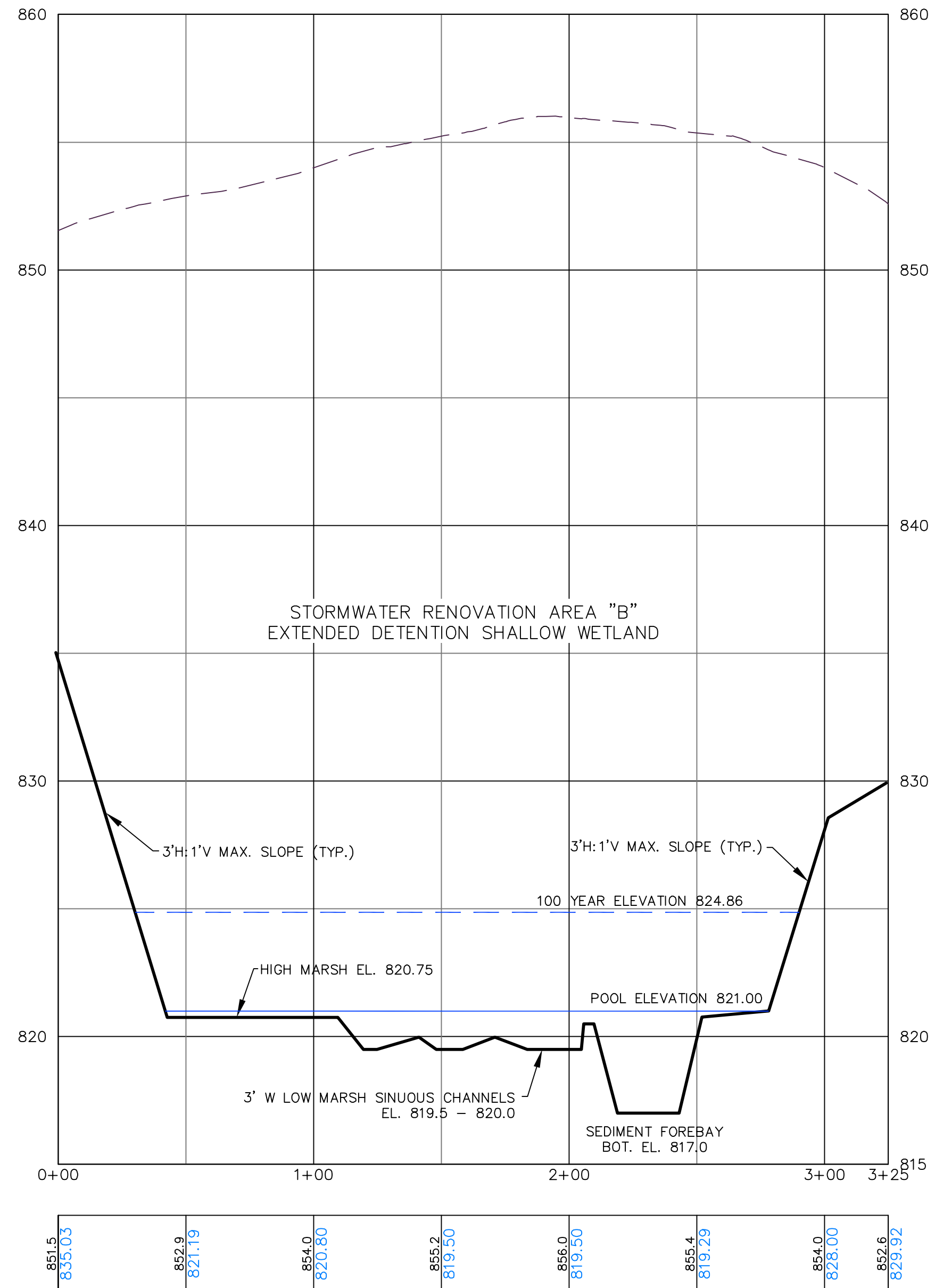

SECTION D-D

PLANTING SCHEDULE FOR EXTENDED DETENTION SHALLOW WETLAND BASIN A

Quantity	Botanical Name	Common Name	Size	Spacing
Low Marsh				
250	<i>Peltandra virginica</i> ²	Arrow Arum	2" plug	2 ft on center
250	<i>Pontederia cordata</i> ²	Pickereelweed	2" plug	2 ft on center
300	<i>Sagittaria latifolia</i> ¹	Northern Arrowhead	2" plug	2 ft on center
300	<i>Schoenoplectus acutus</i> ³	Hardstem Bulrush	2" plug	2 ft on center
High Marsh				
850	<i>Carex comosa</i>	Bearded Sedge	2" plug	2 ft on center
850	<i>Juncus effusus</i>	Soft Rush	2" plug	2 ft on center
850	<i>Panicum virgatum</i>	Switchgrass	2" plug	2 ft on center
850	<i>Schoenoplectus pungens</i>	Three Square Bulrush	2" plug	2 ft on center
Forebay				
75	<i>Peltandra virginica</i> ²	Arrow Arum	2" plug	2 ft on center
75	<i>Pontederia cordata</i> ²	Pickereelweed	2" plug	2 ft on center
75	<i>Sagittaria latifolia</i> ^{1,2}	Northern Arrowhead	2" plug	2 ft on center
75	<i>Schoenoplectus acutus</i> ³	Hardstem Bulrush	2" plug	2 ft on center
Micropool				
100	<i>Peltandra virginica</i> ²	Arrow Arum	2" plug	2 ft on center
100	<i>Pontederia cordata</i> ²	Pickereelweed	2" plug	2 ft on center
100	<i>Sagittaria latifolia</i> ^{1,2}	Northern Arrowhead	2" plug	2 ft on center
100	<i>Schoenoplectus acutus</i> ³	Hardstem Bulrush	2" plug	2 ft on center

Notes:
 1. Don't plant in Fall.
 2. Plant in areas of inundation up to 12" deep.
 3. Plant in areas of inundation up to 36" deep.
 4. Marsh areas and a 5-foot wide shelf around the outer perimeter of the forebay and micropool shall consist of a minimum of 10 inches of topsoil with at least 8 percent organic carbon by weight.

PLANTING SCHEDULE FOR EXTENDED DETENTION SHALLOW WETLAND BASIN B

Quantity	Botanical Name	Common Name	Size	Spacing
Low Marsh				
200	<i>Peltandra virginica</i> ²	Arrow Arum	2" plug	2 ft on center
200	<i>Pontederia cordata</i> ²	Pickereelweed	2" plug	2 ft on center
150	<i>Sagittaria latifolia</i> ¹	Northern Arrowhead	2" plug	2 ft on center
150	<i>Schoenoplectus acutus</i> ³	Hardstem Bulrush	2" plug	2 ft on center
High Marsh				
250	<i>Carex comosa</i>	Bearded Sedge	2" plug	2 ft on center
250	<i>Juncus effusus</i>	Soft Rush	2" plug	2 ft on center
250	<i>Panicum virgatum</i>	Switchgrass	2" plug	2 ft on center
200	<i>Schoenoplectus pungens</i>	Three Square Bulrush	2" plug	2 ft on center
Forebay				
50	<i>Peltandra virginica</i> ²	Arrow Arum	2" plug	2 ft on center
50	<i>Pontederia cordata</i> ²	Pickereelweed	2" plug	2 ft on center
50	<i>Sagittaria latifolia</i> ^{1,2}	Northern Arrowhead	2" plug	2 ft on center
50	<i>Schoenoplectus acutus</i> ³	Hardstem Bulrush	2" plug	2 ft on center
Micropool				
100	<i>Peltandra virginica</i> ²	Arrow Arum	2" plug	2 ft on center
50	<i>Pontederia cordata</i> ²	Pickereelweed	2" plug	2 ft on center
50	<i>Sagittaria latifolia</i> ^{1,2}	Northern Arrowhead	2" plug	2 ft on center
50	<i>Schoenoplectus acutus</i> ³	Hardstem Bulrush	2" plug	2 ft on center

Notes:
 1. Don't plant in Fall.
 2. Plant in areas of inundation up to 12" deep.
 3. Plant in areas of inundation up to 36" deep.
 4. Marsh areas and a 5-foot wide shelf around the outer perimeter of the forebay and micropool shall consist of a minimum of 10 inches of topsoil with at least 8 percent organic carbon by weight.

NO.	REVISION	DATE
1	REV. PER SITING COUNCIL REVIEW	13 FEB 15
2	REV. PER CT DEEP REVIEW	24 FEB 15

Previous Editions Obsolete

STORMWATER RENOVATION AREA CROSS SECTIONS & PLANTING SCHEDULES

CPV TOWANTIC ENERGY CENTER

OXFORD CONNECTICUT

CIVIL C1

CORNERSTONE PROFESSIONAL PARK, SUITE D-101
 43 SHERMAN HILL ROAD
 WOODBURY CONNECTICUT (203) 266-0778

PROFESSIONAL ENGINEER
 LICENSE NO. 17206

DATE: 26 SEP 14
 PROJ. NO.: 98132
 CADD FILE NAME: 98132
 DRAWING NO.: C 325

EROSION AND SEDIMENT CONTROL DEVICES

1. THE FOLLOWING EROSION AND SEDIMENT CONTROL DEVICES SHALL BE IMPLEMENTED AS PART OF THE SITE DEVELOPMENT. THESE DEVICES SHALL BE INSTALLED AS INDICATED ON THE DRAWINGS OR AS DESCRIBED BELOW. FOR FURTHER REFERENCE SEE THE STATE OF CONNECTICUT 2002 GUIDELINES FOR SOIL EROSION AND SEDIMENT CONTROL (THE GUIDELINES).

2. ORGANIC MULCHES (HAY OR STRAW), OR NETTING AND MATS ARE TO BE USED TO PREVENT EROSION BY PROTECTING THE EXPOSED SOIL, AND TO PROMOTE THE GROWTH OF VEGETATION. ORGANIC MULCH MATERIALS AND APPLICATION RATES SHALL BE IN ACCORDANCE WITH FIGURE 7-1 OF THE 2002 GUIDELINES FOR SOIL EROSION AND SEDIMENT CONTROL OF THE STATE OF CONNECTICUT ("GUIDE"). STRAW OR HAY MULCH MUST BE ANCHORED IMMEDIATELY AFTER SPREADING USING A TRACTOR-DRAWN MULCH ANCHORING TOOL. LIQUID MULCH BINDERS, NETTING OR OTHER MEANS OF ANCHORING ALLOWED BY THE "GUIDE". MULCHES MUST BE INSPECTED PERIODICALLY AND, IN PARTICULAR, AFTER RAINSTORMS, AND RE-APPLIED IMMEDIATELY IF EROSION IS OBSERVED.

3. TEMPORARY SEDIMENTATION BASINS A & B SHALL BE CONSTRUCTED TO PROVIDE SEDIMENTATION CONTROL AND WATER QUALITY ENHANCEMENT FOR THE STORMWATER RUNOFF FROM THE CONSTRUCTION AREA. REFER TO THE SEQUENCE OF CONSTRUCTION NOTES.

4. RIPRAP APRONS SHALL BE USED TO REDUCE RUNOFF VELOCITIES AND PROTECT EXPOSED SURFACES FROM CONCENTRATED FLOWS. INSTALLATION DETAILS ARE PROVIDED ON SHEET 7, TITLED "DETAILS" OF THIS PLAN SET.

5. VEGETATIVE COVERS (TEMPORARY AND PERMANENT) SHALL BE INSTALLED TO STABILIZE SOIL AND REDUCE DAMAGE FROM SEDIMENT DEPOSITS, WIND AND/OR RUNOFF EROSION. VEGETATIVE COVERS SHALL BE INSTALLED ON ALL DISTURBED AREAS NOT INTENDED FOR PRIMARY CONSTRUCTION AND NOT PROTECTED BY OTHER EROSION CONTROL MEASURES.

CONSTRUCTION SEQUENCE

IN ORDER TO ENSURE THAT THE EFFECTIVENESS OF THE EROSION AND SEDIMENTATION CONTROL MEASURES IS OPTIMIZED, THE FOLLOWING SEQUENCE OF CONSTRUCTION ACTIVITIES SHALL BE FOLLOWED:

A PRE-CONSTRUCTION MEETING WILL BE SET UP AND TAKE PLACE PRIOR TO THE START OF ANY CONSTRUCTION.

PHASE I: FILL IN WETLANDS AREA 1 AND WETLANDS AREA 4 (30 – 60 DAYS)

1. FIELD STAKEOUT THE LIMITS OF ALL CONSTRUCTION ACTIVITIES.

2. INSTALL ANTI-TRACKING PAD AT CONSTRUCTION ENTRANCE AS SHOWN ON THE PLAN. INSTALL WATER BARS AND HAYBALE BARRIERS AS NECESSARY TO CONTROL DRAINAGE ALONG THE ENTRY DRIVE. AT THE END OF EACH WORKING DAY, ANY ACCUMULATED SILT SHALL BE SWEEPED FROM THE EXISTING TOWN ROADS.

3. CLEAR ALL VEGETATION WITHIN THE CONSTRUCTION AREA. ALL TREES/SHRUBS LESS THAN 6" IN DIAMETER SHALL BE CHIPPED AND STORED ON THE SITE. DO NOT REMOVE STUMPS.

4. HAYBALES AND/OR SILTATION FENCE AND OTHER EROSION CONTROL FEATURES WILL BE PLACED AS SHOWN ON THE ENCLOSED PLAN PRIOR TO THE START OF ANY CONSTRUCTION.

5. REMOVE STUMPS ONLY FROM CONSTRUCTION AREA REQUIRED FOR FILLING OF THE WETLANDS AREA AFTER EROSION CONTROL MEASURES ARE IN PLACE.

6. FILL IN THE WETLANDS AREAS USING ON-SITE MATERIAL. ON-SITE MATERIAL TO BE TAKEN FROM ALREADY CLEARED AREAS THAT ARE PROPOSED AS FUTURE CUTS. FILL TO BE PLACED IN 12" LIFTS AND COMPACTED AS NECESSARY.

7. SEED ALL DISTURBED AREAS.

PHASE II: CONSTRUCT SEDIMENT & EROSION CONTROL MEASURES (30 – 60 DAYS)

1. FIELD STAKEOUT THE LIMITS OF ALL CONSTRUCTION ACTIVITIES

2. INSTALL HAYBALES AND/OR SILTATION FENCE AROUND BOUNDARY OF THE CONSTRUCTION AREA. CLEAR AREAS SUFFICIENT TO CONSTRUCT TEMPORARY DIVERSION SWALES TO TEMPORARY SEDIMENT TRAP "A".

3. GRUB AND CLEAR THE AREA FOR THE CONSTRUCTION OF TEMPORARY SEDIMENTATION TRAP "A" AND TEMPORARY DIVERSION SWALES DISCHARGING TO THE TEMPORARY SEDIMENT TRAP.

4. COMMENCE EARTHWORK AND GRADING FOR TEMPORARY SEDIMENTATION TRAP "A". CONSTRUCT BASIN BERM, OUTLET STRUCTURES, AND PERFORATED RISERS ON THE OUTLET STRUCTURES PER THE DETAIL ON SHEET C321. CONSTRUCT POND DISCHARGE OUTLET PIPING TO EXISTING CATCH BASINS ON WOODRUFF HILL ROAD.

5. MATERIAL EXCAVATION FROM AREA OF TEMPORARY SEDIMENT TRAP "A" SHALL BE USED AS FILL MATERIAL IN EASTERN AND WESTERN PORTIONS OF THE SITE, EXCESS MATERIAL MAY BE TRUCKED OFF SITE.

6. GRUB AND CLEAR AREAS SUFFICIENT FOR CONSTRUCTION OF TEMPORARY SEDIMENTATION TRAP "B" AND TEMPORARY DIVERSION SWALES DISCHARGING TO THE TEMPORARY SEDIMENT TRAP.

7. CONSTRUCT TEMPORARY DIVERSION SWALE AT TOP OF CUT SLOPE ABOVE TRAP "B" TO DIVERT CLEAN WATER FROM THE CONSTRUCTION AREA.

8. COMMENCE EARTHWORK AND GRADING FOR TEMPORARY SEDIMENTATION TRAP "B". CONSTRUCT BASIN BERM, OUTLET STRUCTURE, AND PERFORATED RISER ON THE OUTLET STRUCTURE PER THE DETAIL ON SHEET C321. CONSTRUCT POND DISCHARGE OUTLET PIPING TO PROPOSED DRAINAGE OUTLET ON EASTERN SIDE OF PROPERTY (TO EXISTING 24" PIPE UNDER LOT 9 DRIVEWAY).

9. MATERIAL EXCAVATION FROM AREA OF TEMPORARY SEDIMENT TRAP "B" SHALL BE USED AS FILL MATERIAL IN EASTERN AND WESTERN PORTIONS OF THE SITE, EXCESS MATERIAL MAY ALSO BE TRUCKED OFF SITE.

PHASE III: CONSTRUCTION OF PERIMETER ROAD, MAIN PLANT AREA AND STORM DRAINAGE (APPROX. 2 YEARS)

1. COMMENCE CLEARING AND GRUBBING NECESSARY TO CONSTRUCT PERMANENT PERIMETER ROAD AND REMINDER OF POWER PLANT PAD AREA.

2. CLEAR AND GRADE SWITCHYARD AND STORAGE TANK AREA TO ELEVATION 830.0 AND STABILIZE SLOPES BY SEEDING. SLOPES STEEPER THAN 3:1 SHALL RECEIVE SLOPE BLANKET PROTECTION AND HYDROSEEDING. USE AREAS DESIGNATED ON THE SITE PLANS FOR TEMPORARY STOCKPILE OF TOPSOIL.

4. COMMENCE INSTALLATION OF GAS, WATER, SEWER AND TELEPHONE LINES.

5. PLACE COMPACTED FILL ALONG WEST SITE BOUNDARY FOR THE CONSTRUCTION OF THE PERIMETER ROAD. STABILIZE THE FILL AS REQUIRED.

6. INSTALL ADDITIONAL SILT FENCING AND BERMS WITHIN PLANT AREA WHERE NECESSARY.

7. COMPLETE GRADING ALONG THE EASTERN BOUNDARY. STABILIZE SLOPES.

8. CONSTRUCT PERIMETER ROAD. PERFORM WORK IN INCREMENTS. COORDINATE WORK WITH THE INTERNAL FOUNDATION WORK FOR STRUCTURES AND FINAL GRADING OF THE SEDIMENTATION BASIN.

10. COMMENCE INSTALLATION OF DRAINAGE WITHIN THE POWER PLANT PAD AREA.

11. COMPLETE CONSTRUCTION OF ALL CATCH BASINS AND MANHOLES REQUIRED TO CONVEY SITE RUNOFF TO STORMWATER RENOVATION AREAS "A" & "B".

PHASE IV: CONSTRUCT SWITCHYARD AND UNDERGROUND UTILITIES (APPROX. 1 YEAR)

1. COMPLETE ALL REMAINING EARTHWORK OPERATIONS.

2. REMOVE EXCESS SOIL FROM THE SWITCHYARD AREA. INSTALL DRAINAGE, CONSTRUCT CABLE TRENCHES AND COMPLETE GRADING OF THE SWITCHYARD AREA.

3. INSTALL GRAVEL BASE COURSE FOR THE PERIMETER ROAD AND PARKING.

4. COMMENCE CONSTRUCTION OF FOUNDATIONS AND INSTALLATION OF UNDERGROUND UTILITIES IN THE POWER BLOCK AREA. REMOVE EXCESS SOIL FROM THE STORAGE TANK AREA AND CONSTRUCT TANK FOUNDATIONS.

5. INSTALL CRUSHED STONE IN THE AIR COOLED CONDENSER AND OTHER AREAS.

6. INSTALL ASPHALT CONCRETE SURFACE PAVING.

7. PROVIDE PAINT STRIPING FOR PARKING AS INDICATED ON THE DRAWINGS. INSTALL SIGNS.

8. LOAM, MULCH SEED AND FERTILIZE ALL REMAINING DISTURBED AREAS.

9. CONVERT TEMPORARY SEDIMENTATION TRAPS "A" & "B" INTO STORMWATER RENOVATION AREAS BY REMOVING THE BASIN OUTLET RISER AND CLEANING THE BASIN OF DEPOSITED MATERIALS.

10. REMOVE THE STABILIZED CONSTRUCTION ENTRANCE.

11. REMOVE ROCK CHECK DAMS, HAY BALES, AND LEVEL SPREADERS.

PHASE V: CONSTRUCT PERIMETER FENCE & REMOVE TEMPORARY SEDIMENT & EROSION CONTROL MEASURES (60 DAYS)

1. INSTALL CHAIN LINK SECURITY FENCE AND GATES AROUND THE SITE.

2. INSTALL CHAIN LINK SECURITY FENCE AND GATES AROUND SWITCHYARD.

3. COMPLETE SEEDING AND PLANTING.

4. REMOVE ALL SEDIMENT ACCUMULATED AHEAD OF ALL SEDIMENT BARRIERS.

5. REMOVE SILT FENCES AFTER ALL SLOPES ARE STABILIZED AND REVEGETATED.

GENERAL NOTES

1. A PROJECT MANAGER FROM COMPETITIVE POWER VENTURES, INC. IS THE RESPONSIBLE PARTY FOR IMPLEMENTING THE EROSION AND SEDIMENT CONTROL PLAN. THE RESPONSIBILITY INCLUDES THE INSTALLATION AND MAINTENANCE OF CONTROL MEASURES AND INFORMING ALL PARTIES CONCERNED ON THE CONSTRUCTION SITE OF THE REQUIREMENTS AND OBJECTIVES OF THE PLAN. THE ON-SITE CONSTRUCTION MANAGER SHALL BE RESPONSIBLE FOR HAVING THE EROSION CONTROL MEASURES CHECKED WEEKLY AND AFTER EVERY STORM. ALL ITEMS IDENTIFIED DURING INSPECTION AS THOSE REQUIRING MAINTENANCE/REPLACEMENT SHALL BE COMPLETED IMMEDIATELY.

2. PRIOR TO INITIATING CONSTRUCTION, A PRE-CONSTRUCTION MEETING SHALL BE SCHEDULED AND CONDUCTED INCLUDING THE FOLLOWING ATTENDEES: THE PROJECT MANAGER FROM COMPETITIVE POWER VENTURES, INC., ON-SITE CONSTRUCTION MANAGER, SITE CONTRACTOR, TOWN ENGINEER, AND OTHERS AS MAY BE REQUIRED BY THE CT SITING COUNCIL.

3. THE CUMULATIVE POST PEAK DEVELOPMENT RUN-OFF RATES WILL BE KEPT TO LESS THAN THE PRE-DEVELOPMENT RUN-OFF RATES FROM THE SITE THROUGH THE USE OF ON-SITE DETENTION BASINS.

4. EXISTING WETLANDS AND WATERCOURSES DOWN SLOPE FROM THE PROJECT SITE SHALL BE PROTECTED FROM SEDIMENT POLLUTION BY INSTALLING APPROPRIATE EROSION AND SEDIMENT CONTROL DEVICES, AS INDICATED ON THE VARIOUS EROSION CONTROL PLANS.

5. THE CONTRACTOR SHALL PRESERVE EXISTING VEGETATION. TEMPORARY MULCHING AND SEEDING SHALL BE USED TO PREVENT AND MINIMIZE EROSION.

6. TO REDUCE EROSION HAZARDS, CONSTRUCTION SHALL BE PHASED AS INDICATED ON THIS SHEET AND CONTRACT DRAWINGS TO MINIMIZE LAND DISTURBANCE AT ANY GIVEN TIME. WHERE CONSTRUCTION ACTIVITIES HAVE PERMANENTLY CEASED OR HAVE TEMPORARILY BEEN SUSPENDED FOR MORE THAN SEVERAL DAYS, SOIL STABILIZATION MUST BE IMPLEMENTED WITHIN THREE DAYS. AREAS WHICH REMAIN INACTIVE FOR AT LEAST THIRTY DAYS SHALL RECEIVE TEMPORARY SEEDING IN ACCORDANCE WITH THE GUIDELINES.

7. THE CONTRACTOR MUST INSTALL ANY ADDITIONAL TEMPORARY AND/OR PERMANENT MEASURES WHICH MAY BE NECESSARY TO CONTROL EROSION/SEDIMENTATION ON- AND OFF-SITE DEPENDING ON WEATHER CONDITIONS AND WORK SEQUENCE.

8. THE PAVED AREAS SHALL BE KEPT TO A MINIMUM TO MINIMIZE IMPERVIOUS AREAS.

9. DEWATERING WASTEWATERS SHALL BE DISCHARGED BY INFILTRATION INTO THE GROUND.

10. THE CONTRACTOR MUST ENSURE THAT NO LITTER, DEBRIS, BUILDING MATERIALS OR SIMILAR MATERIALS ARE DISCHARGED IN THE WATERS OF THE STATE.

TEMPORARY SEDIMENT TRAPS

1. TWO TEMPORARY SEDIMENTATION TRAPS "A" & "B" WILL BE INSTALLED DURING CONSTRUCTION. THE AMOUNT OF SEDIMENT ENTERING THE BASINS WILL BE MINIMIZED BY THE USE OF SEDIMENT FOREBAYS AT THE INLETS TO THE PONDS. EACH SEDIMENTATION TRAP SHALL BE FITTED WITH A TEMPORARY OUTLET STRUCTURE ON THE DRAIN LINE OUTLET PIPE TO CONTROL OUTFLOW FROM THE BASIN.

2. SEDIMENT WHICH HAS ACCUMULATED IN THE TEMPORARY SEDIMENT TRAPS SHALL BE REMOVED AFTER REACHING A DEPTH OF 6" OR GREATER.

2. AFTER TRIBUTARY DRAINAGE AREAS HAVE BEEN STABILIZED, THE ACCUMULATED SEDIMENT WITHIN THE BASINS SHALL BE REMOVED. TEMPORARY SEDIMENTATION TRAPS "A" & "B" SHALL BE CONVERTED INTO PERMANENT STORMWATER RENOVATION BASINS.

PERMANENT EROSION CONTROL MEASURES

ALL PERMANENT EROSION CONTROL MEASURES SHALL BE INSTALLED IN STRICT ACCORDANCE WITH THE RECOMMENDATIONS OF THE "GUIDELINES". THE FOLLOWING PERMANENT EROSION CONTROL MEASURES HAVE BEEN DESIGNED AS PART OF THE EROSION AND SEDIMENT CONTROL PLAN:

1. PERMANENT VEGETATIVE COVER SHALL BE ESTABLISHED ON ALL EXPOSED/DISTURBED AREAS THAT ARE NOT SUBJECT TO OTHER RESTORATION (PAVING, RIPRAP, ETC). INSTALLATION AND MAINTENANCE REQUIREMENTS OF CHAPTER 6 OF THE "GUIDELINES" SHALL BE FOLLOWED. EXPOSED AREAS SHALL BE LOADED, LIMED, FERTILIZED AND SEEDED. LIMESTONE AND FERTILIZER SHALL BE APPLIED IN ACCORDANCE WITH THE RESULTS OF SOIL TESTING OR AS RECOMMENDED BY THE "GUIDELINES". ALL PERMANENT SEEDING WILL BE DONE IN THE SPRING OR LATE SUMMER (BEFORE OCTOBER 31). ANY AREAS TO BE SEEDED OUTSIDE OF THIS TIME FRAME SHALL BE COVERED WITH AN EROSION CONTROL BLANKET TO STABILIZE THE SOIL UNTIL GROWTH CAN BE ESTABLISHED. SEEDING MIXTURES SHALL BE SELECTED IN ACCORDANCE WITH FIGURES 6-2 OR 6-3 OF THE "GUIDELINES" OR AS RECOMMENDED BY THE SOIL CONSERVATION SERVICE. HYDROSEEDING SHALL BE USED WHERE INDICATED ON THE PLANS AND IN CRITICAL AREAS. MULCH SHALL BE APPLIED AND MAINTAINED AS RECOMMENDED UNDER "EROSION AND SEDIMENT CONTROL DEVICES" ABOVE. SLOPES STEEPER THAN 3:1 SHALL RECEIVE NORTH AMERICAN GREEN S75 OR S150 STRAW TURF REINFORCEMENT BLANKET OR APPROVED EQUAL.

2. THE RIPRAP APRONS AND PLUNGE POOLS SHALL BE CONSTRUCTED AND STABILIZED AT THE PIPE, OUTLETS PRIOR TO DIRECTING RUNOFF TO EITHER STORMWATER RENOVATION AREA AND AT ALL STORM DRAINAGE OUTLETS.

TEMPORARY EROSION AND SEDIMENT CONTROL MEASURES

THE FOLLOWING ARE PLANNED AS TEMPORARY EROSION/SEDIMENTATION CONTROL MEASURES DURING CONSTRUCTION:

1. A CRUSHED STONE STABILIZED CONSTRUCTION ENTRANCE SHALL BE PLACED AT THE SITE ACCESS ONTO WOODRUFF HILL ROAD.

2. FILTER FABRIC SILT FENCE SHALL BE INSTALLED ALONG THE DOWN GRADIENT SIDE OF ALL FILL SECTIONS. SILT FENCE WILL BE MAINTAINED IN PLACE UNTIL THE TRIBUTARY AREA PROTECTED BY THE FENCE IS REVEGETATED OR STABILIZED BY PERMANENT MEASURES. SYNTHETIC FILTER FABRIC, POST MATERIAL, SPACING AND EMBEDMENT, AND TRENCH DETAILS, SHALL BE AS SHOWN ON THE DRAWINGS. FILTER BARRIER SHALL BE INSPECTED IMMEDIATELY AFTER EACH RAINFALL GREATER THAN 0.1 INCH AND AT LEAST DAILY DURING PROLONGED RAINFALL. REFER TO THE CHAPTER 7 OF THE "GUIDELINES" FOR ADDITIONAL MAINTENANCE REQUIREMENTS.

3. DUST CONTROL SHALL BE USED TO PREVENT BLOWING AND MOVEMENT OF DUST FROM EXPOSED SOIL SURFACES AND REDUCE THE PRESENCE OF DUST WHICH MAY CAUSE OFF-SITE DAMAGE, BE A HEALTH HAZARD TO HUMANS, WILDLIFE AND PLANT LIFE. THE NEED FOR DUST CONTROL WILL BE MINIMIZED BY REDUCING AREA OF LAND DISTURBANCE AT ANY ONE TIME, MAINTAINING AS MUCH VEGETATION AS PRACTICABLE, USE OF MULCHING AND TEMPORARY VEGETATIVE COVER. THE CONTRACTOR SHALL USE MECHANICAL SWEEPERS ON PAVED AREAS AND UTILIZE FINE WATER SPRAYS NEAR SOURCES OF DUST. THE EXPOSED SOIL AREAS SHALL BE PERIODICALLY MOISTENED. SPRAY-ON ADHESIVES DILUTED IN WATER MAY BE USED.

4. TEMPORARY SOIL STOCKPILES SHALL BE PROTECTED BY A SEDIMENT BARRIER. SIDE SLOPES OF THE STOCKPILES SHALL NOT EXCEED 2 TO 1. THE STOCKPILES SHALL BE STABILIZED WITHIN THIRTY DAYS OF FORMATION OF THE STOCKPILE BY TEMPORARY SEEDING OR COVERING WITH MULCH.

5. TEMPORARY VEGETATIVE COVERS SHALL BE INSTALLED ON ALL DISTURBED AREAS NOT INTENDED FOR PRIMARY CONSTRUCTION AND HAVING THE POTENTIAL TO PRODUCE SEDIMENT AND CAUSE ON- AND OFF-SITE DAMAGES. SUCH AREAS BASED ON RECOMMENDATIONS SHALL BE COVERED WITH TOPSOIL AND SEEDED OF FIGURE 6-1 OF THE "GUIDELINES". FOR ADDITIONAL SEEDING REQUIREMENTS REFER TO CHAPTER 6 OF THE "GUIDELINES".

6. STONE CHECK DAMS SHALL BE INSTALLED AT ANY EVIDENT CONCENTRATED FLOW DISCHARGE POINTS.

7. STORM DRAIN CATCH BASIN INLET PROTECTION SHALL BE PROVIDED THROUGH THE USE OF FILTER FABRIC FENCE OR STONE BARRIERS AROUND THE CATCH BASINS AS INDICATED ON THE SEDIMENT AND EROSION CONTROL DRAWINGS. THE BARRIERS SHALL ONLY BE REMOVED WHEN THE TRIBUTARY DRAINAGE AREA HAS BEEN STABILIZED.

STORM DRAINAGE SYSTEM MAINTENANCE

STORMWATER RENOVATION AREAS:

Semiannual:

1. Cut or mow grass lined swales in Spring & Fall. Swales adjacent to the proposed roadway or units may be mowed more frequently.

2. Inspect for and remove invasive vegetation.

3. Clean and remove debris from inlet and outlet structures.

Annual:

1. Inspect sediment forebay area. Remove sediment once it has built up to a depth 12" or greater in the forebays for Basins A & B.

2. Remove excess leaves and debris. Monitor matter that is left in place over winter months to insulate the soil and add organic matter to the soil. Removal criteria shall be when plant matter is smothering or killing vegetation and aesthetics.

5. Prune trees and shrubs as needed.

6. Add supplemental plantings or seed as needed to maintain 80% area cover for turf areas and 50% area cover for tree/shrub/fern areas.

CATCH BASINS, PIPING, SWALES AND LEVEL SPREADERS:

Catch basins, storm drainage piping, swales and level spreaders will be inspected on an annual basis. Any floatables, trash, debris or sediment build up shall be removed by a licensed contractor. Grass-lined swales and level spreaders will be mowed.

The on-site catch basins, storm drainage manholes, swales, stormwater renovation basins and all aspects of the storm drainage system must be maintained in good working condition in accordance with the intent of these plans.

CONSTRUCTION OF STORMWATER RENOVATION AREA BERMS

A. MATERIALS

1. Fill material shall be free of frozen material, sod, brush, roots, stumps and other organic material. Earth embankments shall contain no stones over six inches in diameter. The material used in the core portion of the embankment shall be the most pervious material obtained from the borrow areas, as required. The more pervious materials shall be used in the outer fill portion of the embankment as shown on the plans.

2. The impervious core fill material shall be glacial till, to be provided in sufficient quantities to complete the work. Fill to be approved by the Engineer prior to placement. Glacial till to consist of hard and durable particles or fragments and shall be free from organic matter and other objectionable materials. Glacial till shall conform to the following gradation requirements.

U. S. Standard Sieve Size	Percentage Passing By Weight
3 inch	100
No. 4	60-95
No. 10	50-95
No. 40	30-95
No. 100	20-65
No. 200	10-40

B. BERM FOUNDATION PREPARATION

1. All tree clearing shall be flogged prior to any cutting or clearing.

2. The area where the berm is to be constructed shall be cleared and grubbed of all topsoil and other organic materials to a depth of at least 24". Unless otherwise specified on the plans, berm foundation areas shall be scarified to a minimum depth of three inches prior to placement of fill material.

C. PLACEMENT OF FILL

1. All erosion control measures shall be erected prior to placement/excavation of material.

2. No fill shall be placed until the foundation preparation and excavations in the foundation have been completed and approved by the Engineer. No fill shall be placed on a frozen surface nor fill frozen material be incorporated.

3. Embankment material shall be placed in horizontal layers in 12 inch loose lifts. During construction, the surface of the fill shall be sloped to drain. Each layer or lift shall extend over the entire area of the fill.

4. The fill shall be free from lenses, pockets, streaks, or layers of material differing substantially in texture or gradation from the surrounding material. The more pervious material shall be placed in the outside portion of the berm or as indicated on the drawings. The finished fill shall be shaped and graded to the lines and grade shown on the drawings.

5. Pipe backfill shall be placed in horizontal layers not to exceed 6- 8 inch loose lifts and shall be brought up uniformly around the outlet pipe and flared end section.

D. MOISTURE CONTROL

1. The moisture content of materials in the berm shall be controlled to meet the requirements of Section E "Compaction of Berm". When necessary, moisture shall be added by the use of approved sprinkling equipment. Water shall be added uniformly and each layer shall be thoroughly disked or harrowed to provide proper mixing. Any layer found too wet for compaction shall be allowed to dry before rolling. Placing or rolling of materials on earth fills will not be permitted during or immediately after rainfalls which increase the moisture content beyond the limit of satisfactory compaction. The earth fill shall be brought up uniformly and its top shall be kept graded and sloped so that a minimum of rain water will be retained thereon. Compacted earth fill damaged by runoff shall be replaced immediately by the contractor.

E. COMPACTION

1. Berm material shall be compacted to 95% of the standard proctor density at or near optimum moisture content and by the compaction equipment specified herein. The compaction equipment shall traverse the entire surface of each layer of fill material.

2. Approved tamping rollers shall be used for compacting all parts of the berm. The contractor shall demonstrate the effectiveness of the roller by actual soil compaction test results of the soil to be used in the berm with laboratory work performed by an approved soil testing laboratory. Compaction tests shall include modified proctor and nuclear density tests made at the Engineer's discretion. A minimum of three proctor tests shall be performed and density tests shall be performed every 1500 square feet.

3. Pipe backfill shall be compacted by hand tamping with mechanical tampers. Heavy equipment shall not be operated within three feet of any structure. Equipment shall not be allowed to operate over the outlet culverts until there is at least two feet of cover over the pipes.

F. FINISHING EMBANKMENTS

1. The berm shall be constructed to the elevations, lines and grades and cross sections as shown on the plans. The berm shall be maintained in a manner satisfactory to the Engineer and the Town and surfaces shall be compact and accurately graded before topsoil is placed on them.

2. The topsoil shall be placed at a depth of 5-6" over the disturbed area after completion of construction.

3. Disturbed areas shall be seeded with "New England Environmental Erosion Control Mix for Detention Basins and Moist Sites" or approved equal at a rate of 1 lb. per 5000 square feet or at a rate recommended by the manufacturer.

4. Seeded areas shall be stabilized with hay or mulch until vegetation is firmly established.

5. Seeded areas shall be monitored weekly for erosion and any areas that require reseeding shall be reseed completely and immediately.

EROSION CONTROL NARRATIVE

GENERAL PRINCIPLES

The following general principles shall be maintained as effective means of minimizing erosion and sedimentation during the development process.

Stripping away of vegetation, regrading or other development shall be done in such a way as to minimize erosion.

Grading and development plans shall preserve important natural features, keep cut and fill operations to a minimum, and insure conformity with topography so as to create the least erosion potential and adequately handle the volume and velocity of surface water runoff.

Whenever feasible, natural vegetation shall be retained, protected and supplemented wherever indicated on the site development plan.

The undisturbed area and the duration of exposure shall be kept to a practical minimum.

Disturbed soils shall be stabilized as quickly as possible.

Temporary vegetation and/or mulching shall be used to protect exposed critical areas during development when expected to be exposed in excess of 30 days.

The permanent (final) vegetation and mechanical erosion control measures shall be installed as soon as practical during construction.

Sediment in the runoff water shall be trapped until the disturbed area is stabilized by the use of debris basins, sediment basins, silt traps or similar measures.

All cuts or developments shall be finally graded to provide proper drainage away from buildings and dispose of it without ponding; and all land within a development shall be graded to drain and dispose of surface water without ponding.

Where drainage swales are used to divert surface waters away from buildings, they shall be sodded or planted.

Concentration of surface runoff shall be only permitted by piping and/or through drainage swales or natural watercourses.

Excavation and Fills ---

Slopes created by cuts or fills shall not be steeper than 2:1 and shall be restabilized by temporary or permanent measures, as required during the development process.

Adequate provisions shall be made to prevent surface water from damaging the cut face of excavations or the sloping surfaces of fills.

Cut and fills shall not endanger adjoining property.

All fills shall be compacted to provide stability of material and to prevent undesirable settlement. The fill shall be spread in a series of layers each not exceeding twelve (12) inches in thickness and shall be compacted by a sheep roller or other approved method after each layer is spread.

Fills shall not encroach on natural watercourses, constructed channels or regulated flood plain areas, unless permitted by license or permit from authority having jurisdiction.

Fills placed adjacent to natural watercourses, constructed channels or flood plains shall have suitable protection against erosion during periods of flooding.

Grading shall not be done in such a way as to divert water onto the property of another landowner without their express written consent.

During grading operations, necessary measures for dust control shall be exercised.

Sedimentation and erosion control shall be implemented in accordance with the Guidelines for Soil Erosion and Sediment Control (2002) – State of Connecticut DEP Bulletin 34 or most recent edition.

RESPONSIBILITY FOR THE PLAN

Whenever sedimentation is caused by stripping vegetation and/or grading, it shall be the responsibility of the person, corporation or other entity having responsibility to remove sedimentation from all lower properties, drainage systems and watercourses and to repair any damage at their expense as quickly as possible.

Maintenance of all drainage facilities and watercourses within any subdivision or land development shall be the responsibility of the Connecticut Power Ventures Project Manager until they are accepted by the Town. All control measures will be maintained in effective condition throughout the construction period. Surface inlets shall be kept open and free of sediment and debris. The system shall be checked after every major storm and sediment shall be disposed of at an approved location consistent with the plan.

It shall be the responsibility of any person, corporation or other entity engaging in any act on or near any stream, watercourse or swale or upon the flood plain or right-of-way thereof to maintain as nearly as possible in its present state that same stream, watercourse, swale, flood plain or right-of-way for the duration of the activity and to return it to its original or equal condition after such activity is completed.

Maintenance of drainage facilities or watercourses originating and completely on private property shall be the responsibility of the Connecticut Power Ventures, Inc. their point of open discharge at the property line or at a communal watercourse within property.

No person, corporation or other entity shall block, impede the flow of, alter, construct any structure or deposit any material or thing or commit any act which affects normal or flood flow in any communal stream or watercourse without having obtained prior approval from the Town.

An adequate right-of-way and/or easement shall be provided for all drainage facilities and watercourses which are proposed either for acceptance by the Town or provided by other property owners for the convenience of the OWNER.

Seeded Preparation

Fine grade and rake surface to remove stones larger than 2" in diameter. Install seeded erosion control devices such as surface water diversions. Grade stabilization structures, sediment basins or drainage channels to maintain grassed areas. Apply limestone at a rate of 2 tons/Ac. or 90 lbs/1000 SF unless otherwise required according to soil test results. Apply fertilizers with 10-10-10 at a rate of 300 lbs./Ac. or 7.5 lbs/1000 SF. At least 50% of the nitrogen shall be from organic sources. Work lime and fertilizer into soil uniformly to a depth of 4" with a whisk, springtooth harrow or other suitable equipment following the contour lines.

Seed Application

Apply grass mixtures at rates specified by hand, cyclone seeder or hydroseeder. Increase seed mixture by 10% if hydroseeder is used. Lightly drag or roll the seeded surface to cover seed. Seeding for selected fine grasses should be done between April 1 and June 1 or between August 15 and October 15. If seeding cannot be done during these times, repeat mulching procedure below until seeding can take place or seed with a quick germinating seed mixture to stabilize slopes. A quick germinating seed mixture (Domestic Rye) can be applied between June 15 through August 15 as approved by the Architect or Engineer.

Mulching

Immediately following seeding, mulch the seeded surface with straw, hay or wood fiber at a rate of 1.5 to 2 tons/Ac. except as otherwise specified elsewhere. Mulches should be free of weeds and coarse matter. Spread mulch by hand or mulch blower. Punch mulch into soil surface with track machine or disk harrow set straight up. Mulch material should be "tucked" approximately 2- 3" into the soil surface. Chemical mulch binders or netting, in combination with the straw, hay or wood fibers, will be used where difficult slopes do not allow harrowing by machines.

Grass Seed Mixtures	Temporary Covers	Permanent Covers

11 10 9 8 7 6 5 4 3 2 1

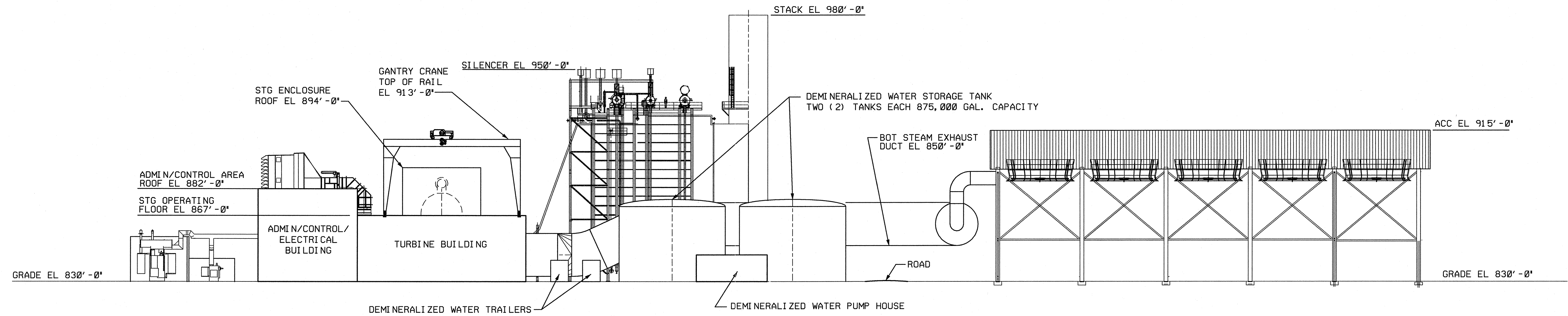

ELEVATION LOOKING EAST
M202

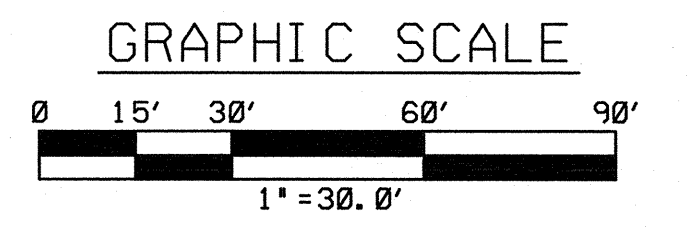

M301.DGN
11:12
08-SEP-2014

Rev No	Revision	Date	Dwn	Chkd	Approved Chief Engr	Rev No	Revision	Date	Dwn	Chkd	Approved Chief Engr	Rev No	Revision	Date	Dwn	Chkd	Approved Chief Engr	Drawing Control				Engineering Review			CPV TOWANTIC ENERGY CENTER OXFORD, CONNECTICUT							
																			Purpose	Approved By	Date	Released By	Date	Disc	Engr	Date	GENERAL ARRANGEMENT ELEVATION LOOKING EAST					
																			For Information	P/24	9/8/14	JDM	9/8/14				BURNS AND ROE ENTERPRISES, INC. Engineers and Constructors - Oradell, NJ Connecticut License No. PEC 39					
																			For Comment								Lead Engineer					
																			For Bid								Scale	Approved for Construction	Work Order	Drawing No	Sh	Rev
																			For Construction							1" = 30.0'	Chief MECHANICAL Engineer	3328	M301		B	



NAFIS & YOUNG

Civil/Environmental Engineering & Surveying

*Allan S. Young, P.E.
James H. Galligan, P.E.
David L. Nafis, P.E., L.S.
Lawrence K. Secor, CHMM*

January 9, 2015

Mr. George Temple, First Selectman
Town of Oxford
486 Oxford Road
Oxford, CT 06478

Re: CPV Towantic, LLC.

Dear Mr. Temple:

Nafis & Young Engineers, Inc. is in receipt of revised plans and Engineering report dated September 29, 2014 from Civil 1 regarding the above-referenced project. We offer the following:

The storm drainage system is designed for a 25-year storm. The detention system is designed to provide a reduction in peak flow for storms ranging from 2-year through 100-year return frequency. Post development stormwater quality protection is achieved thru grass lined swales, vegetated renovation areas and pervious surface treatments. Detention areas are designed to retain and renovate first flush stormwater flows in "water quality cells" within each basin. Approximately 8.7 acres of the plant site will have a pervious surface made up of 8 inch to 12 inch layer of crushed / broken stone to improve groundwater recharge and further reduce peak run off. The Plans submitted use Best Management Practices to improve stormwater quality and minimize impact on down gradient properties. Therefore, Nafis & Young Engineers, Inc. approves the connection of the new stormwater drainage system from the above-referenced site to the Town of Oxford drainage systems.

If you have any questions, please feel free to contact me at 203-314-8041.

Sincerely,

James Galligan, P.E.
Town Engineer of Oxford
Nafis & Young Engineers, Inc.

cc: A. Bazinet

\\Nafis-pta9gh67f\projects\OXFORD\TOWN OF OXFORD\ENGINEERING\CPV Towantic Letter to Temple 01-09-15 JG.doc